

S4 - SS6 - SS7 - SS8

UNI EN 12845 FIRE-FIGHTING SETS WITH SUBMERGED PUMPS



TECHNICAL DATA

Operating range: from 4 to 160 m³/h

Pumped liquid: clean, free of solids and abrasives, non-viscous, non-aggressive, non-crystallised and chemically neutral, with properties similar to water.

Pumped liquid temperature range: from -15 to 70 °C.

Maximum ambient temperature: + 25 °C

Maximum operating pressure: 16 bar (1600kPa) PN16

Special executions on request:

execution with joined cable available on request.

The control panels of the sets with submerged pumps are already fitted on base for quicker installation.

The main and pilot pumps are provided as standard with a 15-metre power cable.

All the 6" and 8" electric pumps (SS6 – SS7 and SS8) are entirely in AISI 304 stainless steel.

GENERAL DATA

NOTES ON UNI EN 12845

UNI EN 12845, the Italian version of European Standard EN 12845, sets the design, installation and maintenance criteria for sprinkler systems. It replaces the earlier Italian standards UNI 9489 and UNI 9490. An automatic sprinkler system is designed to detect the presence of fire and extinguish it during the initial stages, or to keep flames under control until they can be extinguished fully using other means. The classic sprinkler system is composed of: a water source, a fire-fighting pump unit, a series of control valves, and a sprinkler circuit. In its basic execution, it consists of: one or more 4", 6", or 8" submerged electric pumps, plus the 4" compensation pump (jockey), if required. All 4" - 6" - 7" - 8" electric pumps, including main and jockey pumps, are equipped with 15 meter power input cable.

COMPOSITION OF THE PUMP SETS

The pumps of UNI EN 12845 sets will have the same characteristics; in addition:

- if TWO pumps are installed, each pump must deliver the total system load (100 %),
- if THREE pumps are installed, each pump must deliver 50 % of the load required by the design.

NOTE:

In case of single water supply, there are no limitations on the number of electric pumps that can be installed. DAB provides "modular" type sets, so that all the versions contemplated by the UNI EN 12845 standard - OPERATION OF UNI EN 12845 FIRE-FIGHTING PUMP SETS - can be completed.

In normal conditions, (zero water request), the system is under static pressure. The first time there is a water request, the compensation pump activates (if present), reinstating the system pressure. In case of significant water request (or if no compensation pump is installed, or the sprinklers activate), the pressure drops until the two pressure switches connected in series activate the main pump. If the pressure continues to drop, further pumps activate in the same way.

Pressure switch calibration and operation example.

	Maximum pump pressure x 0,8	
Two-pump sets	Pump 1 Max pressure x 0,8	Pump 2 Max pressure x 0,6

E.g. Max pump pressure 10 bar - pump 1 starts at 8 bar, pump 2 starts at 6 bar

Once activated, the main pump continues to operate until it is manually stopped using the STOP pushbutton on the electric control panel.

No protections for stops due to lack of water are permitted. In case of hydrant systems, refer to UNI 10779 - July 07. In addition to prescribing feed pumps in compliance with UNI EN 12845, UNI 10779 allows automatic stopping of the pumps 20 minutes after the closing of the hydrants, in case of non-permanently supervised operation. DAB pump sets are suitable for sprinkler systems with manual stop, and for hydrant systems with automatic stop.

S4 - SS6 - SS7 - SS8

UNI EN 12845 FIRE-FIGHTING SETS WITH SUBMERGED PUMPS

PRESSURE COMPENSATION PUMP - "JOCKEY"

The compensation pump (jockey) is a pump that intervenes when the collection of a small amount of water is required. This avoids pointless starts of the main pumps in case of small system leaks. DAB fire-fighting sets are available with and without jockey pump.

The compensation pump must be installed at the delivery manifold, and includes:

- ball valve on the suction,
- check ball valve on the delivery,
- control pressure switch,
- 20 litre expansion vessel.
- control and protection panels

CONSTRUCTION FEATURES

In the standard versions, the configurations are with multistage centrifugal submerged electric pumps for 4", 6", or 8" wells.

CONSTRUCTION FEATURES OF THE 4" PUMPS

Multistage centrifugal type with radial or semi-axial impellers. Pump and motor directly coupled with rigid coupling. Technopolymer impellers with stainless steel wearing parts, fitted on floating clearance rings made of synthetic low abrasion material, and technopolymer diffusers that impart significant wear resistance to the pump. Pump liner, shaft and coupling, strainer and cable sheath in stainless steel. Base support and upper head in microcast AISI 304 stainless steel; steel check valve incorporated in the head (to be removed for horizontal installation).

CONSTRUCTION FEATURES OF THE 6" - 7" - 8" PUMPS

Mixed flow pumps with diffusers, impellers, brackets, suction case and discharge case completely made of stainless steel AISI 304 in order to provide maximum strength, durability, wear and tear resistance.

The impellers are balanced and locked to the shaft with a specially shaped collet and nut coupling, in order to guarantee ease-to-assembly feature and avoid vibration sensitive malfunctions and noise increase during rotation.

Rubber bearings that drive the shaft are water lubricated and have sand channels to make enable the sand particles leave the pump with the pumped liquid (maximum permissible sand content 50 gr/m3).

Built-in non returned valve provided in order to minimize local friction losses.

Stainless steel strainer provided in order to prevent particles over a certain size from entering the pump.

HYDRAULIC SECTION

Pre-assembled manifold with:

flanged connection for each pump, pressure gauge, pump running notification pressure switch, check valve, butterfly shut-off valve, galvanised steel delivery manifold with pressure gauges and two pump start pressure switches, pressure switch test circuit, expansion vessel (in case of jockey pump).

NOTE: electric and hydraulic connections not supplied by DAB Pumps

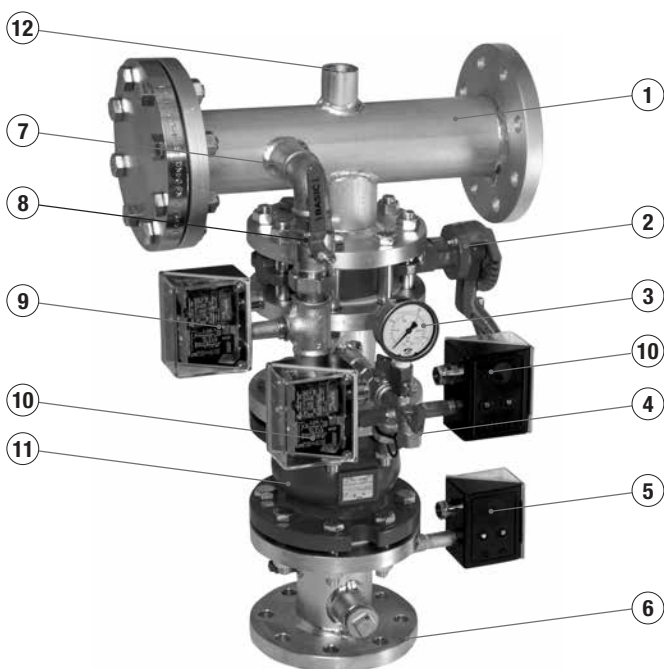

REF.	DESCRIPTION	S4"	SS6"	SS7" SS8"
1	Delivery manifold	DN 50	DN 80	DN 100
2	Butterfly shut-off valve	DN50 PN16	DN80 PN16	DN100 PN16
3	Radial pressure gauge	0-16 bar D=63		
4	Pressure switch manual test valve	-		
5	Running pump pressure switch	KPI36 2-12bar ¼"M		
6	DNA adaptor	DN 50	DN 80	DN 100
7	Jockey pump connection manifold	1"		
8	Jockey pump shut-off valve (version with jockey pump only)	1"		
9	Jockey pump pressure switch (version with jockey pump only)	KPI36 2-12bar ¼"M		
10	Main pump start pressure switches	KPI36 2-12bar ¼"M (x2)		
11	Non-return valve	DN50 PN16	DN80 PN16	DN100 PN16
12	Expansion vessel manifold (version with jockey pump only)	1"		

S4 - SS6 - SS7 - SS8

UNI EN 12845 FIRE-FIGHTING SETS WITH SUBMERGED PUMPS

COOLING LINERS FOR 4" SUBMERSIBLE PUMP

For horizontal installation and/or inside tanks, a cooling liner must be used to safeguard the motor.

Kit of cooling liners of different lengths, used to ensure perfect cooling of the 4" motor in case of installation inside tanks or containers, or in any location where a minimum cooling flow on the motor cannot be guaranteed.

The length of the pipe must be selected based on the type of motor and its power, as indicated in the following table.

POWER INPUT 50 Hz	MOTOR POWER		MOTOR TYPE		
	HP	kW	4GG - 4GX	40L	4TW
SINGLE-PHASE	0,5	0,37	L400 PIPE KIT	L400 PIPE KIT	L525 PIPE KIT
	0,75	0,55			
	1	0,75			L885 PIPE KIT
	1,5	1,1	L525 PIPE KIT	L525 PIPE KIT	
	2	1,5			
	3	2,2	L885 PIPE KIT	L885 PIPE KIT	
	5	3,7			

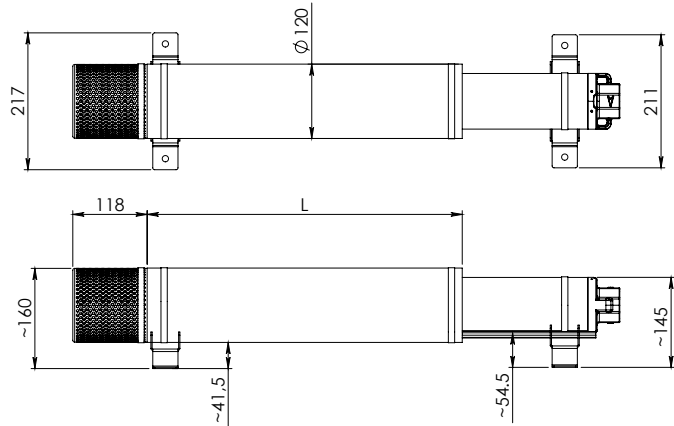

THREE-PHASE	0,5	0,37	L400 PIPE KIT	L400 PIPE KIT
	0,75	0,55		
	1	0,75		
	1,5	1,1	L525 PIPE KIT	L525 PIPE KIT
	2	1,5		
	3	2,2	L885 PIPE KIT	L885 PIPE KIT
	4	3		
	5,5	4		
	7,5	5,5		
	10	7,5		

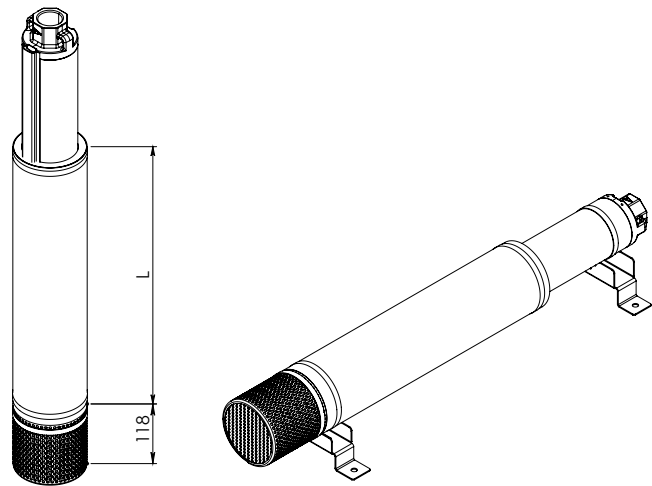

S4 - SS6 - SS7 - SS8

UNI EN 12845 FIRE-FIGHTING SETS WITH SUBMERGED PUMPS

COOLING LINERS FOR 6" SUBMERGED PUMP

For horizontal installation and/or inside tanks, a cooling liner must be used to safeguard the motor.

Kit of cooling liners of different lengths, used to ensure perfect cooling of the 6" motor in case of installation inside tanks or containers, or in any location where a minimum cooling flow on the motor cannot be guaranteed.

The length of the pipe must be selected based on the type of motor and its power, as indicated in the following table.

SUITABLE FOR USE ON S6, SR6 E SM6 ELECTRIC PUMPS COUPLED WITH 6" MOTOR.

POWER INPUT 50 Hz	MOTOR POWER		MOTOR TYPE	
	HP	kW	6GF-6GX	TR6
THREE-PHASE	5,5	4	725 PIPE KIT	960 PIPE KIT
	7,5	5,5		
	10	7,5		
	12,5	9,3		
	15	11	960 PIPE KIT	1220 PIPE KIT
	17,5	13		
	20	15		
	25	18,5		
	30	22	1220 PIPE KIT	1490 PIPE KIT
	35	26		
	40	30		
	50	37		

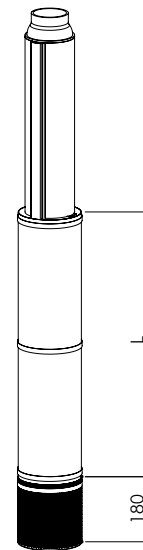
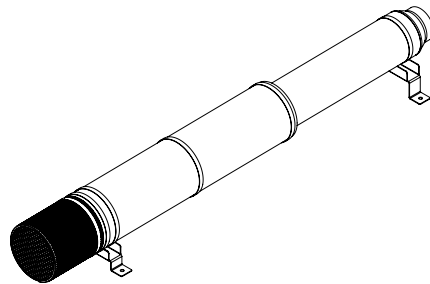
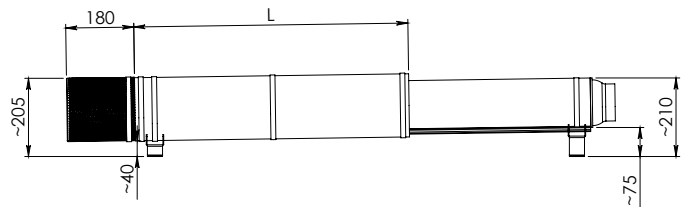
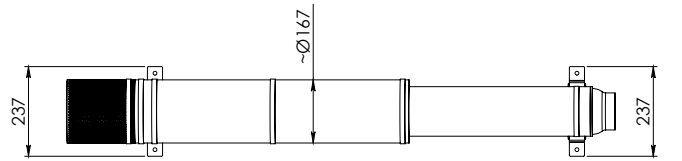

in order to determine the cooling flow speed v [m/s] along the motor liner, the following formula can be used:

$$v = \frac{\frac{Q}{2}}{\pi \cdot \left(\frac{D^2}{4} - \frac{d^2}{4} \right)}$$

On the other hand, in order to determine the correct diameter of the cooling liner, to ensure that the minimum required cooling flow condition is met at a certain pump flow level, the following formula can be used:

$$D = \sqrt{4 \cdot \left(\frac{Q}{v \cdot \pi} + \frac{d^2}{4} \right)}$$

Q [m³/s] = flow at the point of operation of the electric pump.
 D [m] = well diameter.
 d [m] = motor diameter.
 v [m/s] = cooling flow speed.

ELECTRIC PUMP CONTROL PANEL

UNI EN 12845 FIRE-FIGHTING PUMP SETS



TECHNICAL DATA

Nominal power input voltage: 400 V +/- 5%

Phases: 3

Frequency: 50-60 Hz

Number of pumps that can be connected: 1

Maximum nominal power of use:
from 3 to 110 kW (depending on model).

Maximum nominal current of use: from 10 Amp to 250 Amp.

Ambient temperature operation limits: from +4 °C to +40 °C.

Relative humidity (without condensation):

50% at 40 °C MAX (90% a 20 °C)

Max. altitude: 3000 m (a.s.l.).

Protection class: IP55

Control panel construction:

According to EN60204, EN 60439-1, and UNI EN 12845/10779.

COMPONENTS

The control and protection panel includes the following components

INTERIOR OF CABINET

Connector for the powering of a GSM Modem (230 V, protected by fuse).

Motor protection fuses (aM type); current surge relay-motor protectors are not permitted by the standard.

Auxiliary circuit protection fuses (Gg type).

Direct pump starters (up to 7,5 kW).

Star/triangle starters (11 kW and over).

24 V auxiliary circuit transformers.

Alarm relay with terminal box for remote status control (as required by the UNI EN 12845 standard).

System start-up input connection terminal box.

ON FRONT PANEL

Electric pump control unit with:

Multifunction instrument with display (voltmeter, ammeter, cosfi metre, wattmeter, alarms and status).

Start and stop pushbuttons.

Status and alarm notification lamps.

Alarm/notification lamp test pushbutton.

0 - 1 selector (0 = automatic disabled; 1 = automatic on), key removable only for position one (AUTOMATIC ON).

REMOTELY CONTROLLED ALARMS:

Voltage present.

Phase sequence.

Pump start request from the pressure switches.

Pump start request from priming tank.

Pump in operation.

Start failed.

The above alarms can be remotely controlled in the following ways:

With relay wiring to the CSR-1 control panel.

With RS-485 wiring to the CSR-1 control panel.

With GSM Modem inside the cabinet CSR-1, for forwarding status and/or alarm signals (optional).

ELECTRIC PUMP CONTROL PANEL

UNI EN 12845 FIRE-FIGHTING PUMP SETS

ELECTRIC PUMP CONTROL UNIT

The A1 electronic control unit supplied with the control panel offers the following features: automatic start from the pressure switches or the priming float switch, manual start, automatic monitoring of pump set faults and incorrect or unavailable power input voltage.

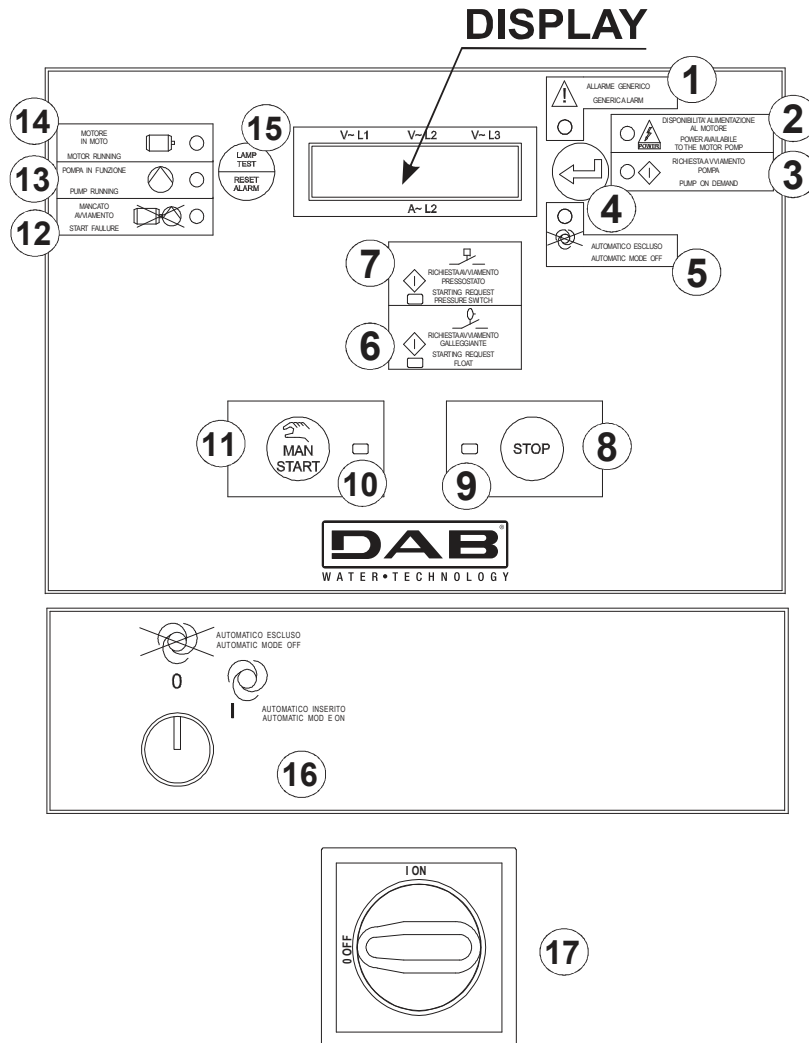

**ALIMENTAZIONE DELLA POMPA SPRINKLER
NON SPEGNERE IN CASO DI INCENDIO**

**SPRINKLER PUMP MOTOR SUPPLY
NOT TO BE SWITCHED OF IN THE EVENT OF FIRE**

REF.	FUNCTION
1	LAMP - Generic alarm
2	LAMP - Power input to the motor detected
3	LAMP - Pump START request
4	Press to display the instruments
5	LAMP - Automatic start disabled
6	LAMP - START request from the priming tank float switch
7	LAMP - START request (call) from the pressure switches
8	MANUAL STOP pushbutton
9	LAMP - MANUAL STOP with STOP pushbutton notification

REF.	FUNCTION
10	LAMP - MANUAL START with MAN START pushbutton notification
11	MANUAL START pushbutton
12	LAMP - Start failed
13	LAMP - ELECTRIC PUMP RUNNING with motor running; detected by the electric pump running pressure switch
14	LAMP - MOTOR RUNNING; controlled by the ammeter detection
15	Reset lamp test pushbutton
16	Automatic mode disabling selector
17	Power input disconnection switch

S4 - SS6 - SS7 - SS8

UNI EN 12845 FIRE-FIGHTING SETS WITH SUBMERGED PUMPS

CONNECTION OF PRESSURE SWITCHES AND PUMP MOTOR TO THE CONTROL PANEL

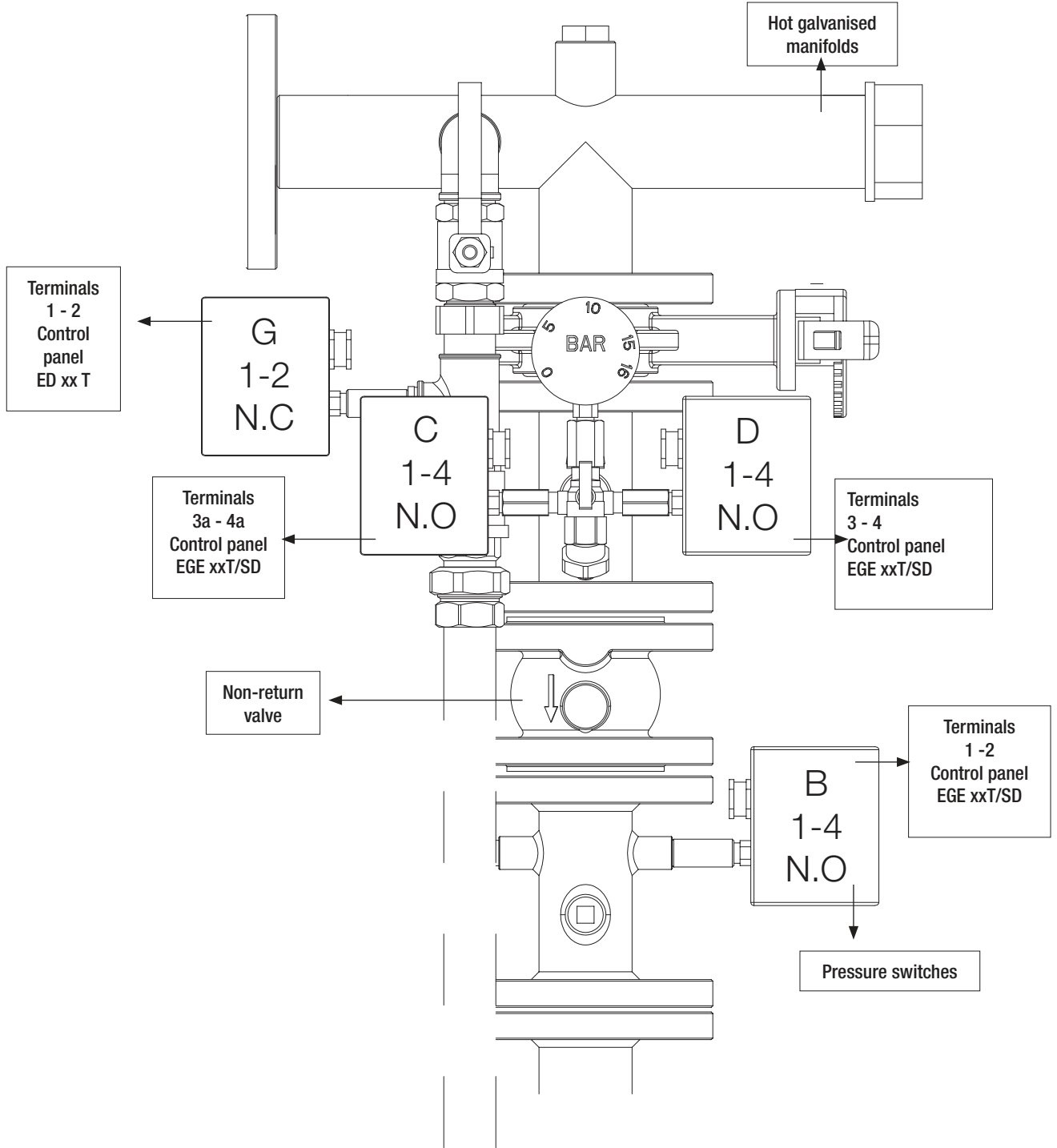

CABLE CONNECTION SEQUENCE FOR SUBMERGED PUMPS WITH START:

DIRECT (DOL)		
MOTOR POWER UP TO 7,5 KW	EGEXX T CONTROL PANEL TERMINAL BOX	SUBMERGED ELECTRIC PUMP CABLE COLOUR
	U1	BLACK
	V1	BLUE or GREY
	W1	BROWN

STAR/TRIANGLE		
MOTOR POWER OVER TO 7,5 KW	EGEXX T SD CONTROL PANEL TERMINAL BOX	SUBMERGED ELECTRIC PUMP CABLE COLOUR
	U1	BLACK
	V1	BLUE or GREY
	W1	BROWN
	U2	BROWN
	V2	BLACK
	W2	BLUE or GREY

S4 - SS6 - SS7 - SS8

UNI EN 12845 FIRE-FIGHTING SETS WITH SUBMERGED PUMPS

EXAMPLES OF CONFIGURATION OF A TWO-PUMP SET WITH JOCKEY PUMP AND FLOW RATE METER

Although not strictly necessary, for installation inside tanks or similar, we still recommend the use of cooling liners.

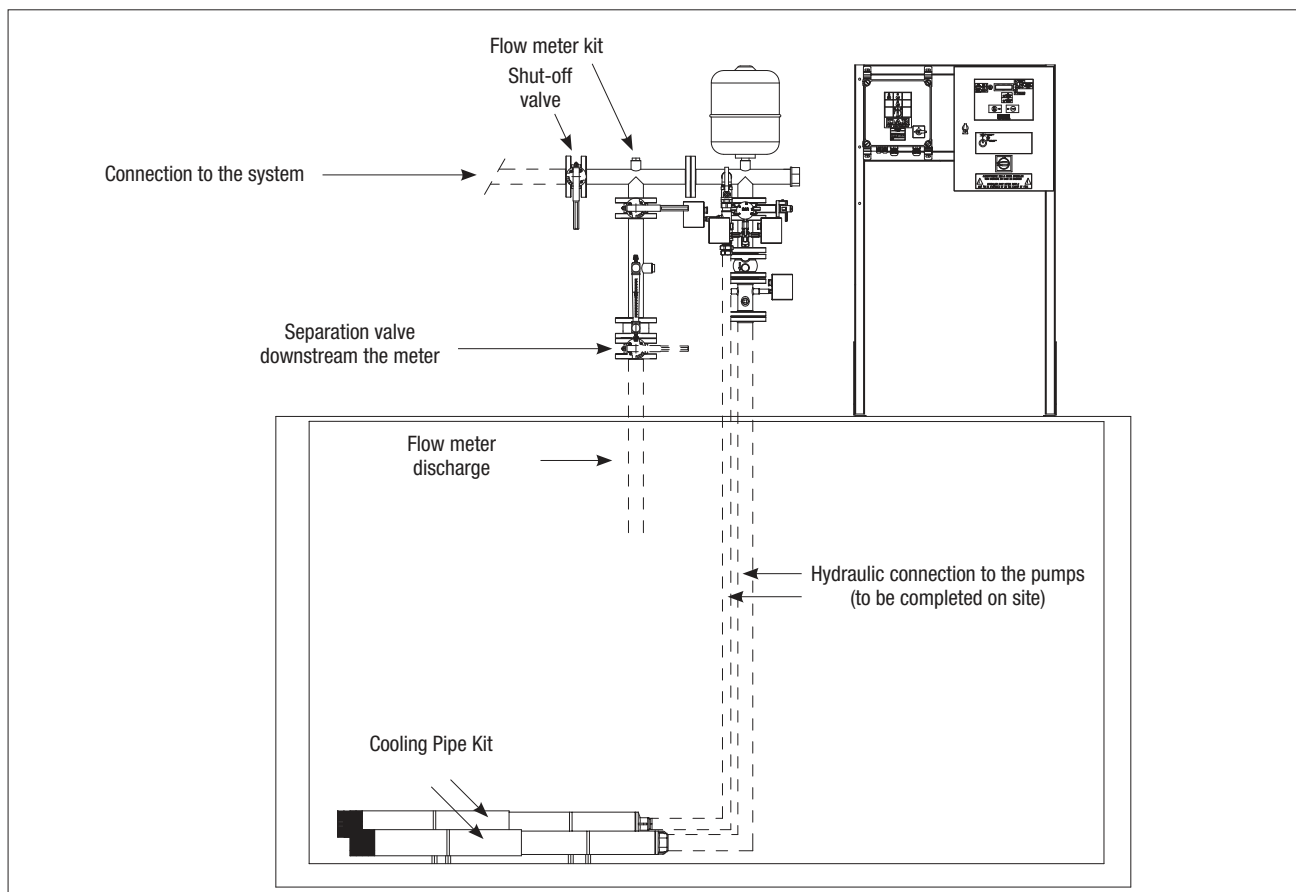
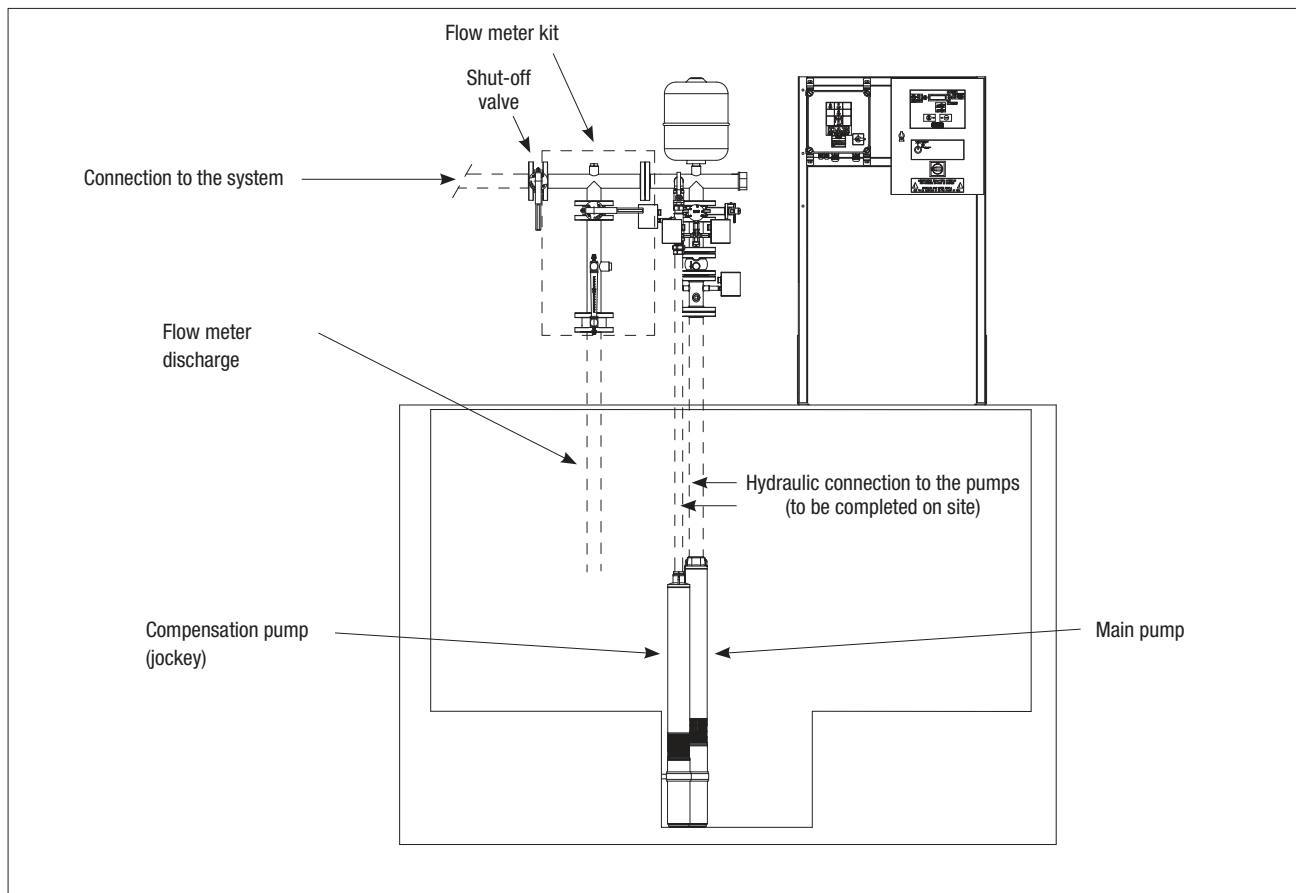

S4 SETS - UNI EN 12845 FIRE-FIGHTING SETS

Pumped liquid temperature range: from 0°C to +40°C - Maximum ambient temperature: from 4°C to +40 °C - Maximum flow rate: 11 m³/h

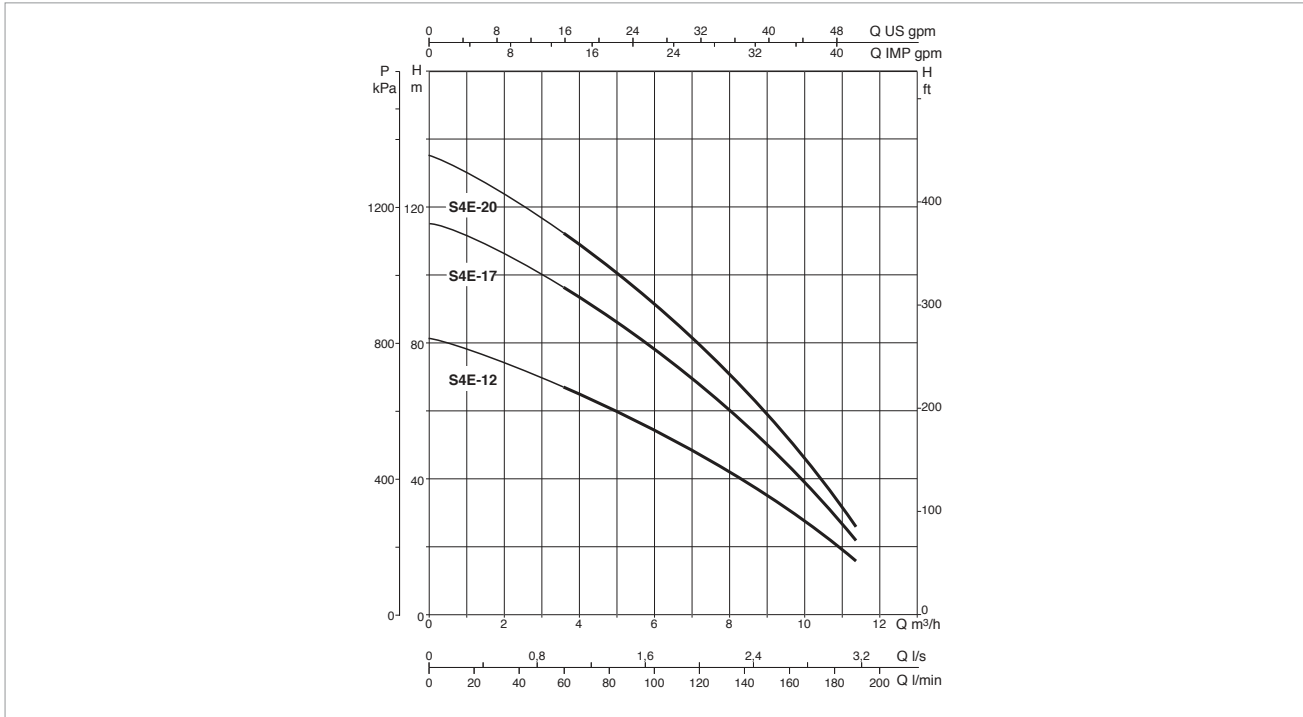

The performance curves are based on kinematic viscosity values = 1 mm²/s and density equal to 1000 kg/m³. Curve tolerance according to ISO 9906.

SETS WITH 1 S4E SUBMERGED PUMP

MODEL	POWER INPUT 50 Hz	P2 NOMINAL		In (A)	CONTROL PANEL MODEL	MAX FLOW RATE m³/h	MAX OBTAINABLE PRESSURE	STANDARD PRESSURE (bar)
		kW	Hp					
1 S4E 12 T 400/50 EN 12845	3 x 400 50 Hz	1.5	2	4.4	EGE 3T 400/50-60	11	8	6.5
1 S4E 17 T 400/50 EN 12845	3 x 400 50 Hz	2.2	3	5.9	EGE 3T 400/50-60	11	11.4	9
1 S4E 20 T 400/50 EN 12845	3 x 400 50 Hz	2.2	3	5.9	EGE 3T 400/50-60	11	13.5	11

SETS WITH 1 S4E SUBMERGED PUMP + JOCKEY PUMP

MODEL	POWER INPUT 50 Hz	P2 NOMINAL		In (A)	CONTROL PANEL MODEL	MAX FLOW RATE m³/h	MAX OBTAINABLE PRESSURE	STANDARD PRESSURE (bar)
		kW	Hp					
1 S4E 12 T 400/50 EN 12845 - S4C 19T	3 x 400 50 Hz	1.5	2	4.4	EGE 3T 400/50-60	11	8	6.5
	3 x 400 50-60 Hz *	1.1 *	1.5 *	3.4 *	ED 1.5T (108320340) *	4.2 *	10.4 *	8 *
1 S4E 17 T 400/50 EN 12845 - S4C 25T	3 x 400 50 Hz	2.2	3	5.9	EGE 3T 400/50-60	11	11.4	9
	3 x 400 50-60 Hz *	1.5 *	2 *	4.4 *	ED 2.5T (108320350) *	4.2 *	13.7 *	11 *
1 S4E 20 T 400/50 EN 12845 - S4C 25T	3 x 400 50 Hz	2.2	3	5.9	EGE 3T 400/50-60	11	13.5	11
	3 x 400 50-60 Hz *	1.5 *	2 *	4.4 *	ED 2.5T (108320350) *	4.2 *	13.7 *	11 *

* Jockey pump

S4 SETS - UNI EN 12845 FIRE-FIGHTING SETS

SETS WITH 1 SUBMERGED PUMP

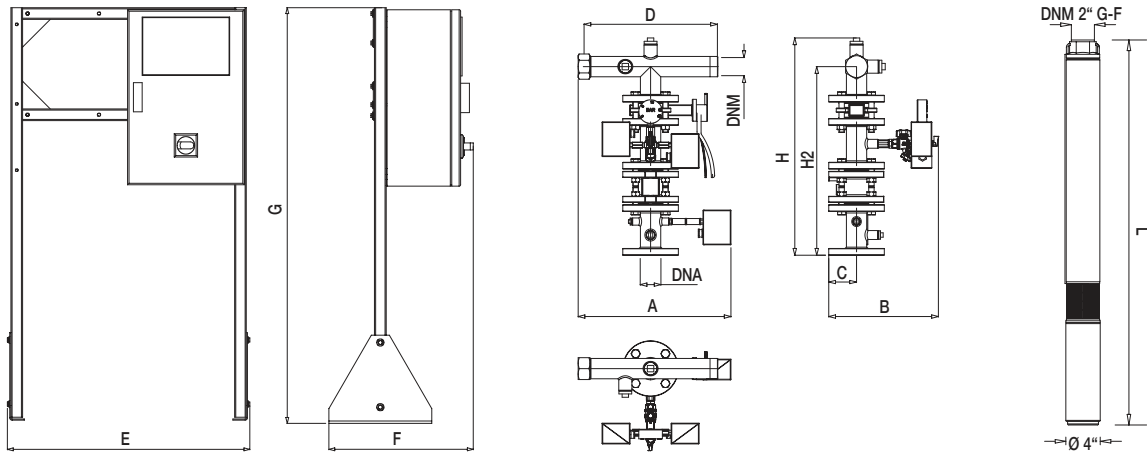

SETS WITH 1 SUBMERGED PUMP + JOCKEY PUMP

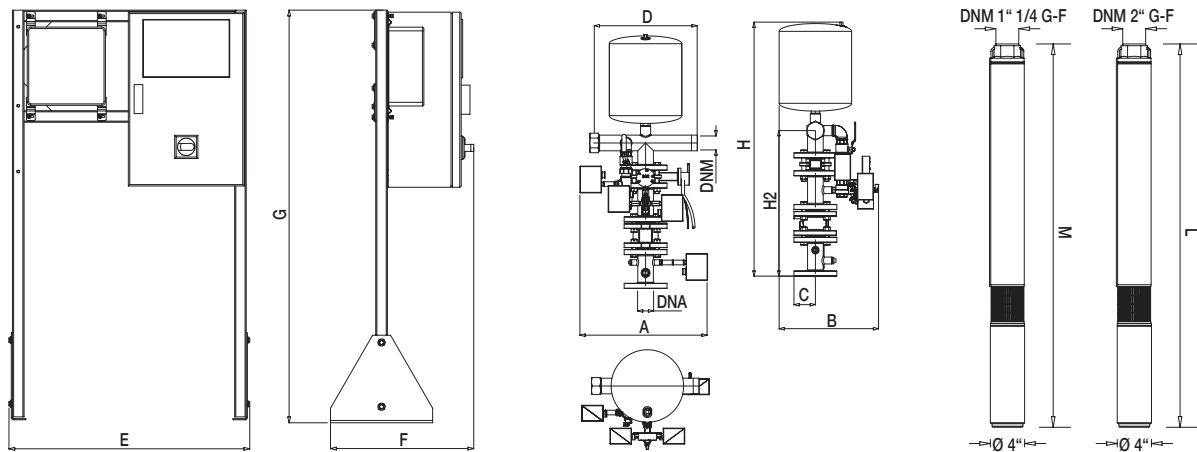

MODEL	A	B	C	D	E	F	G	H	H2	L	M	DNA	DNM	PACKING (bpxh)	WEIGHT kg
1 S4E 12 T 400/50 EN 12845	455	325	83	395	830	490	1415	645	560	1163	-	50	50	1000x1400x2200	137
1 S4E 17 T 400/50 EN 12845	455	325	83	395	830	490	1415	645	560	1502	-	50	50	1000x1400x2200	142
1 S4E 20 T 400/50 EN 12845	455	325	83	395	830	490	1415	645	560	1894	-	50	50	1000x1400x2200	145
1 S4E 12 T 400/50 EN 12845 - S4C 19T	490	385	83	395	830	490	1415	980	560	1163	1086	50	50	1000x1400x2200	172
1 S4E 17 T 400/50 EN 12845 - S4C 25T	490	385	83	395	830	490	1415	980	560	1502	1343	50	50	1000x1400x2200	180
1 S4E 20 T 400/50 EN 12845 - S4C 25T	490	385	83	395	830	490	1415	980	560	1894	1343	50	50	1000x1400x2200	185

S4 SETS - UNI EN 12845 FIRE-FIGHTING SETS

Pumped liquid temperature range: from 0°C to +40°C - Maximum ambient temperature: from 4°C to +40 °C - Maximum flow rate: 27 m³/h

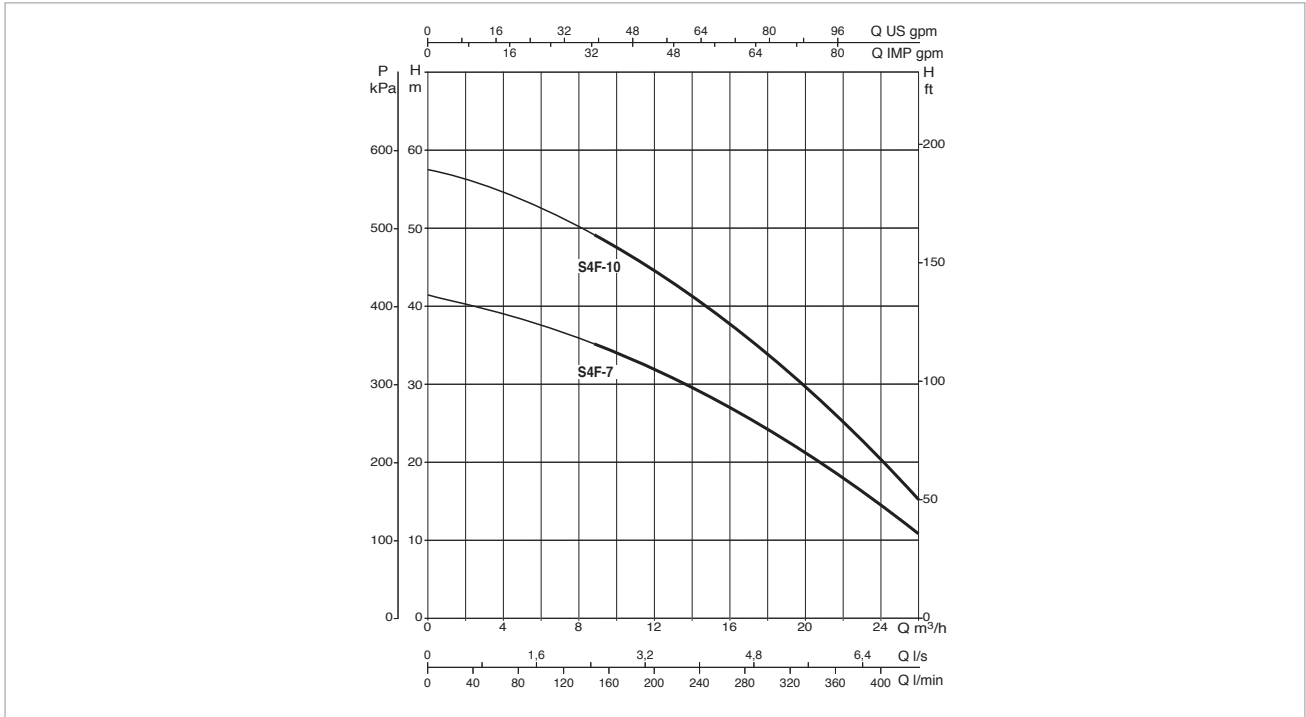

The performance curves are based on kinematic viscosity values = 1 mm²/s and density equal to 1000 kg/m³. Curve tolerance according to ISO 9906.

SETS WITH 1 S4F SUBMERGED PUMP

MODEL	POWER INPUT 50 Hz	P2 NOMINAL		In (A)	CONTROL PANEL MODEL	MAX FLOW RATE m³/h	MAX OBTAINABLE PRESSURE	STANDARD PRESSURE (bar)
		kW	Hp					
1 S4F 7 T 400/50 EN 12845	3 x 400 50 Hz	2.2	3	5.9	EGE 3T 400/50-60	27	4	3
1 S4F 10 T 400/50 EN 12845	3 x 400 50 Hz	3	4	8.3	EGE 3T 400/50-60	27	5.8	4.5

SETS WITH 1 S4F SUBMERGED PUMP + JOCKEY PUMP

MODEL	POWER INPUT 50 Hz	P2 NOMINAL		In (A)	CONTROL PANEL MODEL	MAX FLOW RATE m³/h	MAX OBTAINABLE PRESSURE	STANDARD PRESSURE (bar)
		kW	Hp					
1 S4F 7 T 400/50 EN 12845 - S4C 13T	3 x 400 50 Hz	2.2	3	5.9	EGE 3T 400/50-60	27	4	3
	3 x 400 50-60 Hz *	0.75 *	1 *	2.4 *	ED 2.5T (108320350) *	4.2 *	7.1 *	6 *
1 S4F 10 T 400/50 EN 12845 - S4C 13T	3 x 400 50 Hz	3	4	8.3	EGE 3T 400/50-60	27	5.8	4.5
	3 x 400 50-60 Hz *	0.75 *	1 *	2.4 *	ED 2.5T (108320350) *	4.2 *	7.1 *	6 *

* Jockey pump

S4 SETS - UNI EN 12845 FIRE-FIGHTING SETS

SETS WITH 1 SUBMERGED PUMP

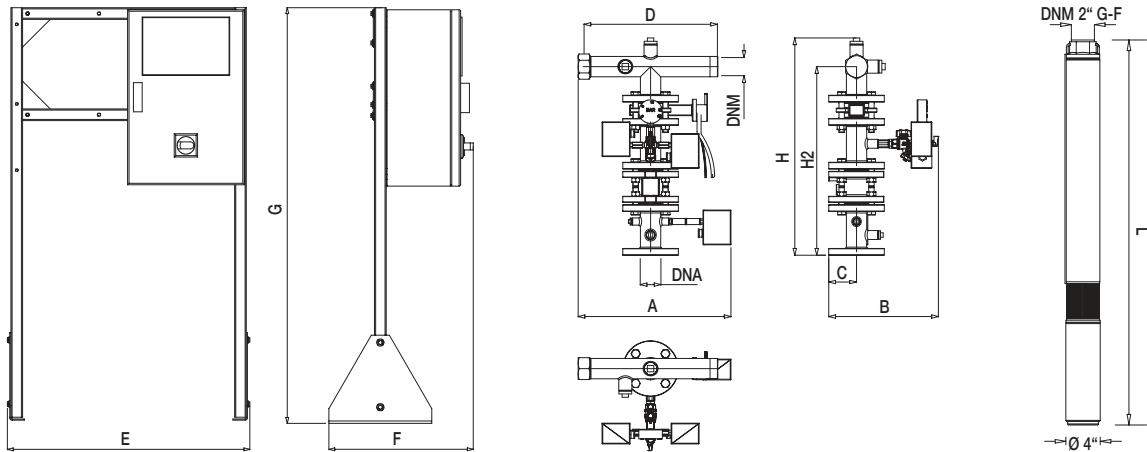

SETS WITH 1 SUBMERGED PUMP + JOCKEY PUMP

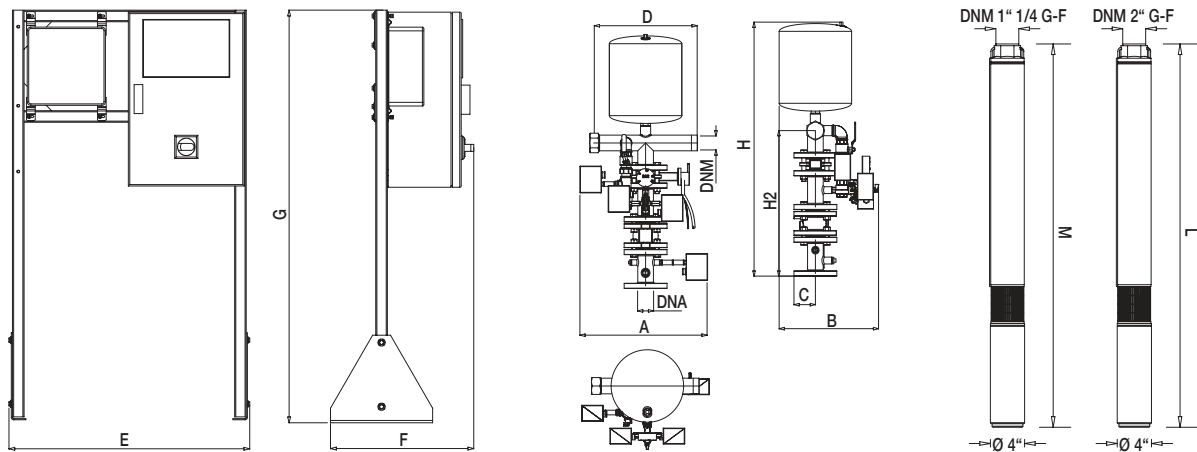

MODEL	A	B	C	D	E	F	G	H	H2	L	M	DNA	DNM	PACKING (bpxh)	WEIGHT kg
1 S4F 7 T 400/50 EN 12845	455	325	83	395	830	490	1415	645	560	1079	-	50	50	1000x1400x2200	125
1 S4F 10 T 400/50 EN 12845	455	325	83	395	830	490	1415	645	560	1491	-	50	50	1000x1400x2200	129
1 S4F 7 T 400/50 EN 12845 - S4C 13T	490	385	83	395	830	490	1415	980	560	1079	871	50	50	1000x1400x2200	185
1 S4F 10 T 400/50 EN 12845 - S4C 13T	490	385	83	395	830	490	1415	980	560	1491	871	50	50	1000x1400x2200	190

S4 SETS - UNI EN 12845 FIRE-FIGHTING SETS

Pumped liquid temperature range: from 0°C to +40°C - Maximum ambient temperature: from 4°C to +40 °C - Maximum flow rate: 27 m³/h

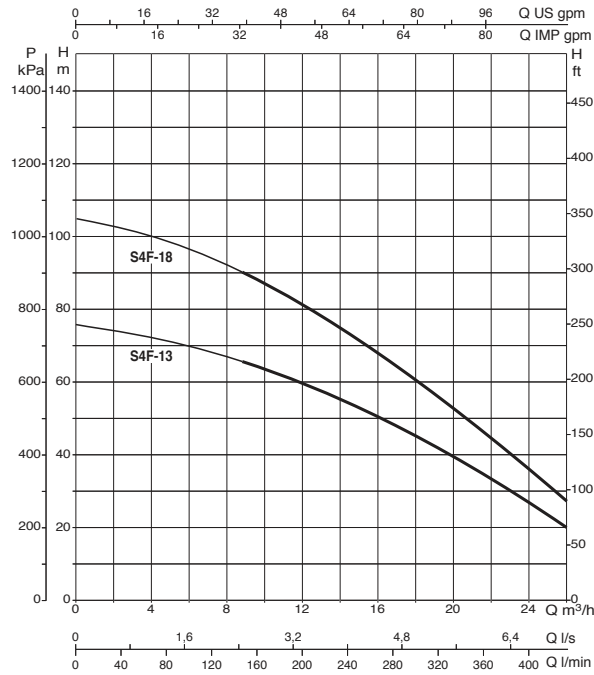

The performance curves are based on kinematic viscosity values = 1 mm²/s and density equal to 1000 kg/m³. Curve tolerance according to ISO 9906.

SETS WITH 1 S4F SUBMERGED PUMP

MODEL	POWER INPUT 50 Hz	P2 NOMINAL		In (A)	CONTROL PANEL MODEL	MAX FLOW RATE m ³ /h	MAX OBTAINABLE PRESSURE	STANDARD PRESSURE (bar)
		kW	Hp					
1 S4F 13 T 400/50 EN 12845	3 x 400 50 Hz	4	5.5	10	EGE 5.5T 400/50-60	27	7.6	6
1 S4F 18 T 400/50 EN 12845	3 x 400 50 Hz	5.5	7.5	14	EGE 5.5T 400/50-60	27	10.4	8

SETS WITH 1 S4F SUBMERGED PUMP + JOCKEY PUMP

MODEL	POWER INPUT 50 Hz	P2 NOMINAL		In (A)	CONTROL PANEL MODEL	MAX FLOW RATE m ³ /h	MAX OBTAINABLE PRESSURE	STANDARD PRESSURE (bar)
		kW	Hp					
1 S4F 13 T 400/50 EN 12845 - S4C 19T	3 x 400 50 Hz	4	5.5	10	EGE 5.5T 400/50-60	27	7.6	6
	3 x 400 50-60 Hz *	1.1 *	1.5 *	3.4 *	ED 1.5T (108320340) *	4.2 *	10.4 *	8 *
1 S4F 18 T 400/50 EN 12845 - S4C 25T	3 x 400 50 Hz	5.5	7.5	14	EGE 5.5T 400/50-60	27	10.4	8
	3 x 400 50-60 Hz *	1.5 *	2 *	4.4 *	ED 2.5T (108320350) *	4.2 *	13.7 *	11 *

* Jockey pump

S4 SETS - UNI EN 12845 FIRE-FIGHTING SETS

SETS WITH 1 SUBMERGED PUMP

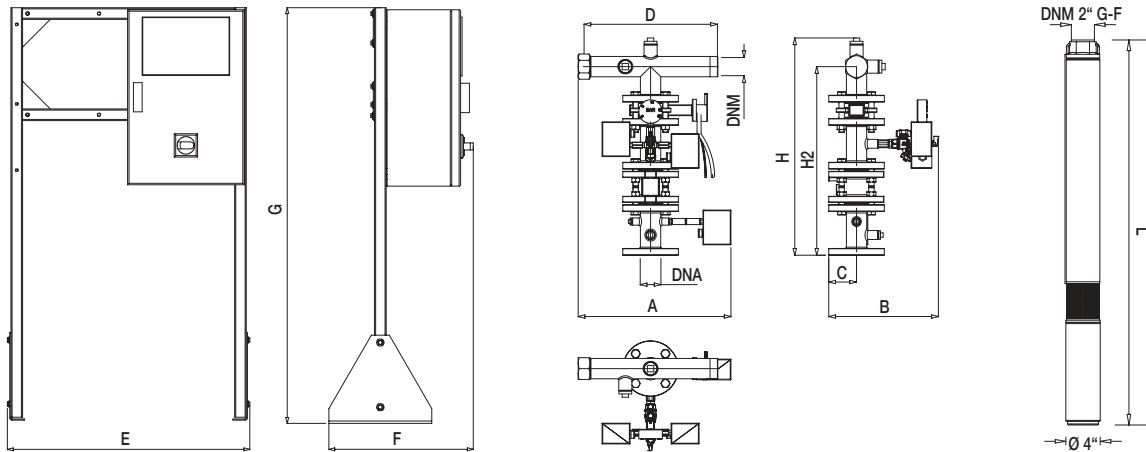

SETS WITH 1 SUBMERGED PUMP + JOCKEY PUMP

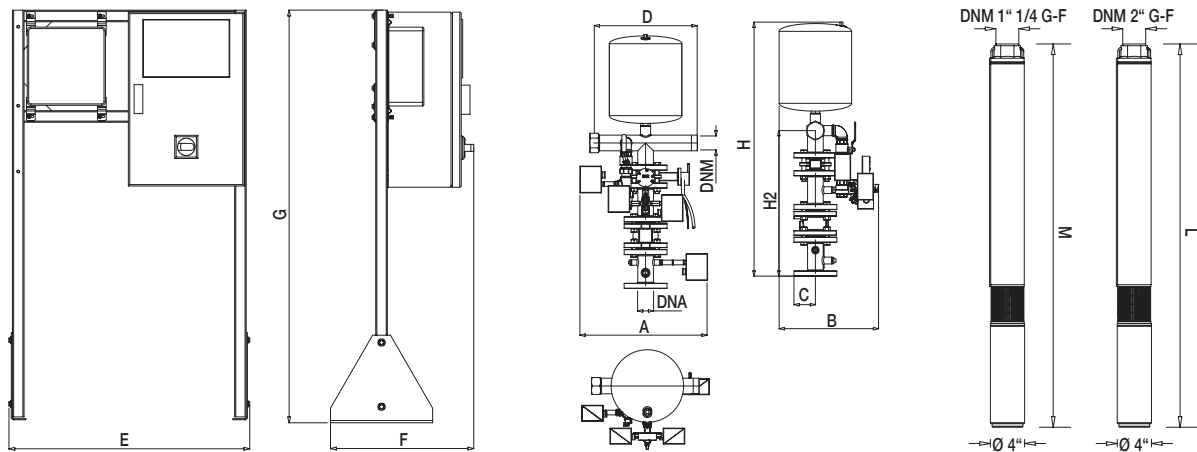

MODEL	A	B	C	D	E	F	G	H	H2	L	M	DNA	DNM	PACKING (bpxh)	WEIGHT kg
1 S4F 13 T 400/50 EN 12845	455	325	83	395	830	490	1415	645	560	1715	-	50	50	1000x1400x2200	153
1 S4F 18 T 400/50 EN 12845	455	325	83	395	830	490	1415	645	560	2156	-	50	50	1000x1400x2200	175
1 S4F 13 T 400/50 EN 12845 - S4C 19T	490	385	83	395	830	490	1415	980	560	1715	1086	50	50	1000x1400x2200	182
1 S4F 18 T 400/50 EN 12845 - S4C 25T	490	385	83	395	830	490	1415	980	560	2156	1343	50	50	1000x1400x2200	213

SS6 SETS - UNI EN 12845 FIRE-FIGHTING SETS

Pumped liquid temperature range: from 0°C to +40°C - Maximum ambient temperature: from 4°C to +40 °C - Maximum flow rate: 36 m³/h

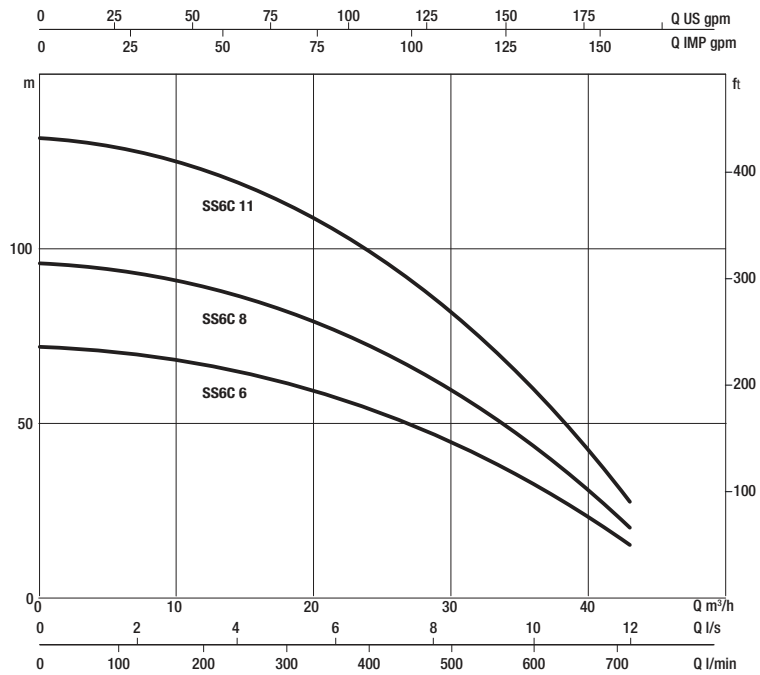

The performance curves are based on kinematic viscosity values = 1 mm²/s and density equal to 1000 kg/m³. Curve tolerance according to ISO 9906.

SETS WITH 1 SS6C SUBMERGED PUMP

MODEL	POWER INPUT 50 Hz	P2 NOMINAL		In (A)	CONTROL PANEL MODEL	MAX FLOW RATE m³/h	MAX OBTAINABLE PRESSURE	STANDARD PRESSURE (bar)
		kW	Hp					
1SS6C 6 T 400/50 EN 12845	3 x 400 50 Hz	5,5	7,5	14	EGE 5.5T 400/50-60	36	6.1	4.5
1SS6C 8 T 400/50 EN 12845	3 x 400 50 Hz	7,5	10	18	EGE 5.5T 400/50-60	36	9.1	7
1SS6C 11 T 400/50 EN 12845	3 x 400 50 Hz	9,2	12,5	22	EGE 7.5T 400/50-60	36	12.2	9.5

SETS WITH 1 SS6C SUBMERGED PUMP + JOCKEY PUMP

MODEL	POWER INPUT 50 Hz	P2 NOMINAL		In (A)	CONTROL PANEL MODEL	MAX FLOW RATE m³/h	MAX OBTAINABLE PRESSURE	STANDARD PRESSURE (bar)
		kW	Hp					
1SS6C 6 T 400/50 EN 12845 - S4C 19T	3 x 400 50 Hz	5,5	7,5	14	EGE 5.5T 400/50-60	36	6.1	4.5
	3 x 400 50-60 Hz *	0.75 *	1 *	2.4 *	ED 2.5T (108320350) *	4.2 *	7.1 *	6 *
1SS6C 8 T 400/50 EN 12845 - S4C 19T	3 x 400 50 Hz	7,5	10	18	EGE 5.5T 400/50-60	36	9.1	7
	3 x 400 50-60 Hz *	1.1 *	1.5 *	3.4 *	ED 1.5T (108320340) *	4.2 *	10.4 *	8 *
1SS6C 11 T 400/50 EN 12845 - S4C 25T	3 x 400 50 Hz	9,2	12,5	22	EGE 7.5T 400/50-60	36	12.2	9.5
	3 x 400 50-60 Hz *	1.5 *	2 *	4.4 *	ED 2.5T (108320350) *	4.2 *	13.7 *	11 *

* Jockey pump

SS6 SETS - UNI EN 12845 FIRE-FIGHTING SETS

SETS WITH 1 SUBMERGED PUMP

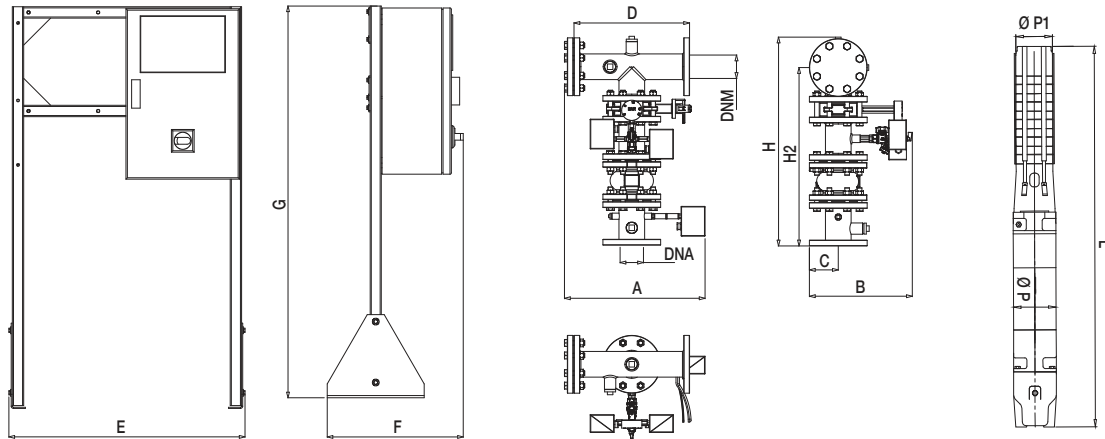

SETS WITH 1 SUBMERGED PUMP + JOCKEY PUMP

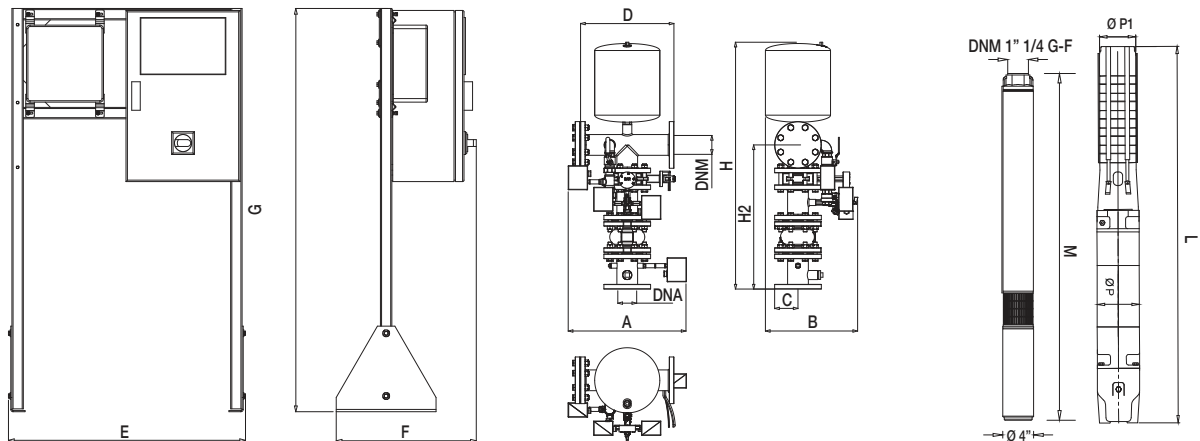

MODEL	A	B	C	D	E	F	G	H	H2	L	M	DNA	DNM	Ø P	Ø P1	PACKING (bpxh)	WEIGHT kg
1SS6C 6 T 400/50 EN 12845	485	355	100	400	830	490	1415	725	615	1470	-	80	80	141	132	1000x1400x2200	193
1SS6C 8 T 400/50 EN 12845	485	355	100	400	830	490	1415	725	615	1689	-	80	80	141	132	1000x1400x2200	202
1SS6C 11 T 400/50 EN 12845	485	355	100	400	830	490	1415	725	615	1999	-	80	80	141	132	1000x1400x2200	190
1SS6C 6 T 400/50 EN 12845 - S4C 19T	505	395	100	400	830	490	1415	1055	615	1470	871	80	80	141	132	1000x1400x2200	256
1SS6C 8 T 400/50 EN 12845 - S4C 19T	505	395	100	400	830	490	1415	1055	615	1689	1086	80	80	141	132	1000x1400x2200	235
1SS6C 11 T 400/50 EN 12845 - S4C 25T	505	395	100	400	830	490	1415	1055	615	1999	1343	80	80	141	132	1000x1400x2200	248

SS6 SETS - UNI EN 12845 FIRE-FIGHTING SETS

Pumped liquid temperature range: from 0°C to +40°C - Maximum ambient temperature: from 4°C to +40 °C - Maximum flow rate: 48 m³/h

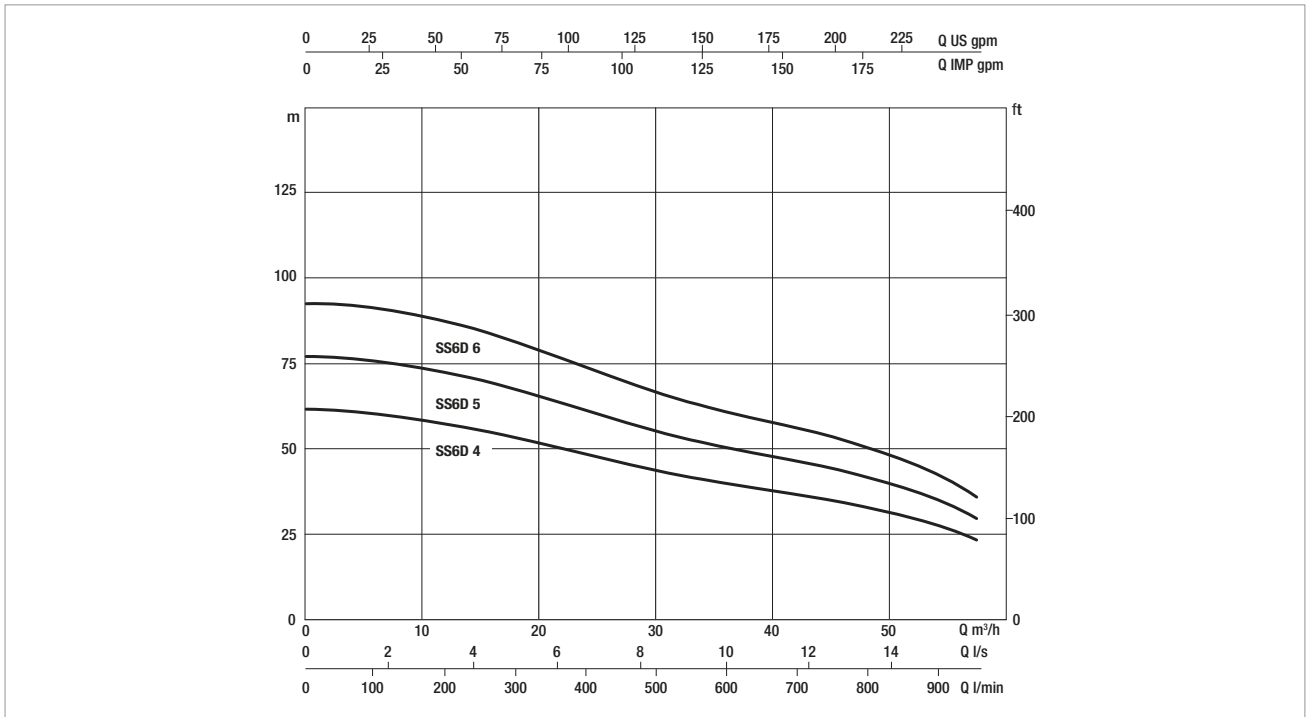

The performance curves are based on kinematic viscosity values = 1 mm²/s and density equal to 1000 kg/m³. Curve tolerance according to ISO 9906.

SETS WITH 1 SS6D SUBMERGED PUMP

MODEL	POWER INPUT 50 Hz	P2 NOMINAL		In (A)	CONTROL PANEL MODEL	MAX FLOW RATE m³/h	MAX OBTAINABLE PRESSURE	STANDARD PRESSURE (bar)
		kW	Hp					
1SS6D 4 T 400/50 EN 12845	3 x 400 50 Hz	7,5	10	18	EGE 5.5T 400/50-60	48	4.8	3.5
1SS6D 5 T 400/50 EN 12845	3 x 400 50 Hz	7,5	10	18	EGE 5.5T 400/50-60	48	6.3	5
1SS6D 6 T 400/50 EN 12845	3 x 400 50 Hz	9,2	12,5	22	EGE 7.5T 400/50-60	48	7.8	6

SETS WITH 1 SS6D SUBMERGED PUMP + JOCKEY PUMP

MODEL	POWER INPUT 50 Hz	P2 NOMINAL		In (A)	CONTROL PANEL MODEL	MAX FLOW RATE m³/h	MAX OBTAINABLE PRESSURE	STANDARD PRESSURE (bar)
		kW	Hp					
1SS6D 4 T 400/50 EN 12845 - S4C 13T	3 x 400 50 Hz	7,5	10	18	EGE 5.5T 400/50-60	48	4.8	3.5
	3 x 400 50-60 Hz *	0.75 *	1 *	2.4 *	ED 2.5T (108320350) *	4.2 *	7.1 *	6 *
1SS6D 5 T 400/50 EN 12845 - S4C 19T	3 x 400 50 Hz	7,5	10	18	EGE 5.5T 400/50-60	48	6.3	5
	3 x 400 50-60 Hz *	0.75 *	1 *	2.4 *	ED 2.5T (108320350) *	4.2 *	7.1 *	6 *
1SS6D 6 T 400/50 EN 12845 - S4C 19T	3 x 400 50 Hz	9,2	12,5	22	EGE 7.5T 400/50-60	48	7.8	6
	3 x 400 50-60 Hz *	1.1 *	1.5 *	3.4 *	ED 1.5T (108320340) *	4.2 *	10.4 *	8 *

* Jockey pump

SS6 SETS - UNI EN 12845 FIRE-FIGHTING SETS

SETS WITH 1 SUBMERGED PUMP

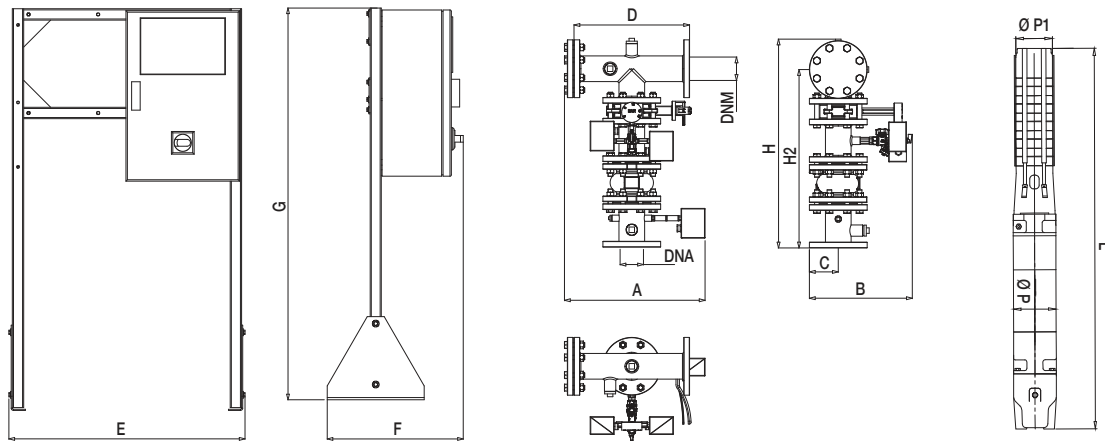

SETS WITH 1 SUBMERGED PUMP + JOCKEY PUMP

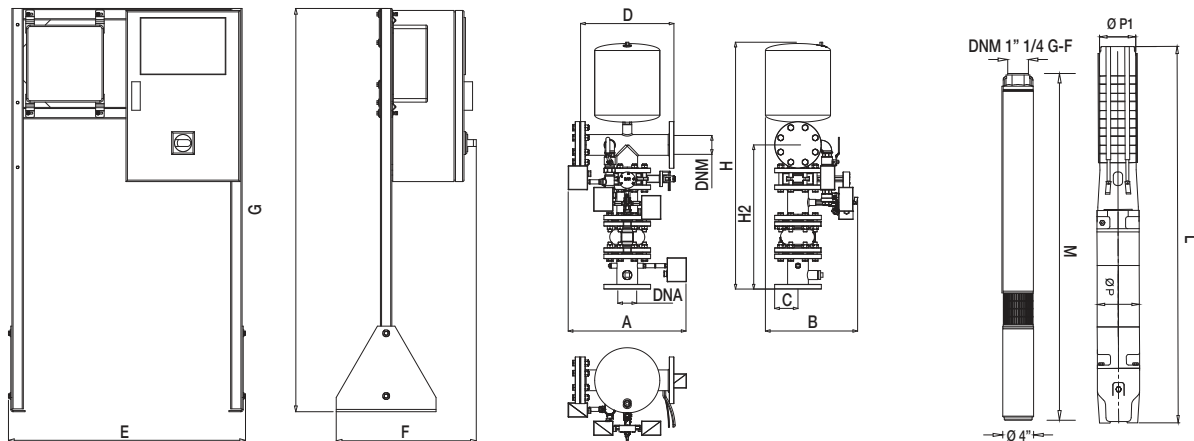

MODEL	A	B	C	D	E	F	G	H	H2	L	M	DNA	DNM	Ø P	Ø P1	PACKING (bpxh)	WEIGHT kg
1SS6D 4 T 400/50 EN 12845	485	355	100	400	830	490	1415	725	615	1378	-	80	80	141	144	1000x1400x2200	196
1SS6D 5 T 400/50 EN 12845	485	355	100	400	830	490	1415	725	615	1490	-	80	80	141	144	1000x1400x2200	200
1SS6D 6 T 400/50 EN 12845	485	355	100	400	830	490	1415	725	615	1627	-	80	80	141	144	1000x1400x2200	192
1SS6D 4 T 400/50 EN 12845 - S4C 13T	505	395	100	400	830	490	1415	1055	615	1378	871	80	80	141	144	1000x1400x2200	228
1SS6D 5 T 400/50 EN 12845 - S4C 19T	505	395	100	400	830	490	1415	1055	615	1490	871	80	80	141	144	1000x1400x2200	232
1SS6D 6 T 400/50 EN 12845 - S4C 19T	505	395	100	400	830	490	1415	1055	615	1627	1086	80	80	141	144	1000x1400x2200	237

SS6 SETS - UNI EN 12845 FIRE-FIGHTING SETS

Pumped liquid temperature range: from 0°C to +40°C - Maximum ambient temperature: from 4°C to +40 °C - Maximum flow rate: 48 m³/h

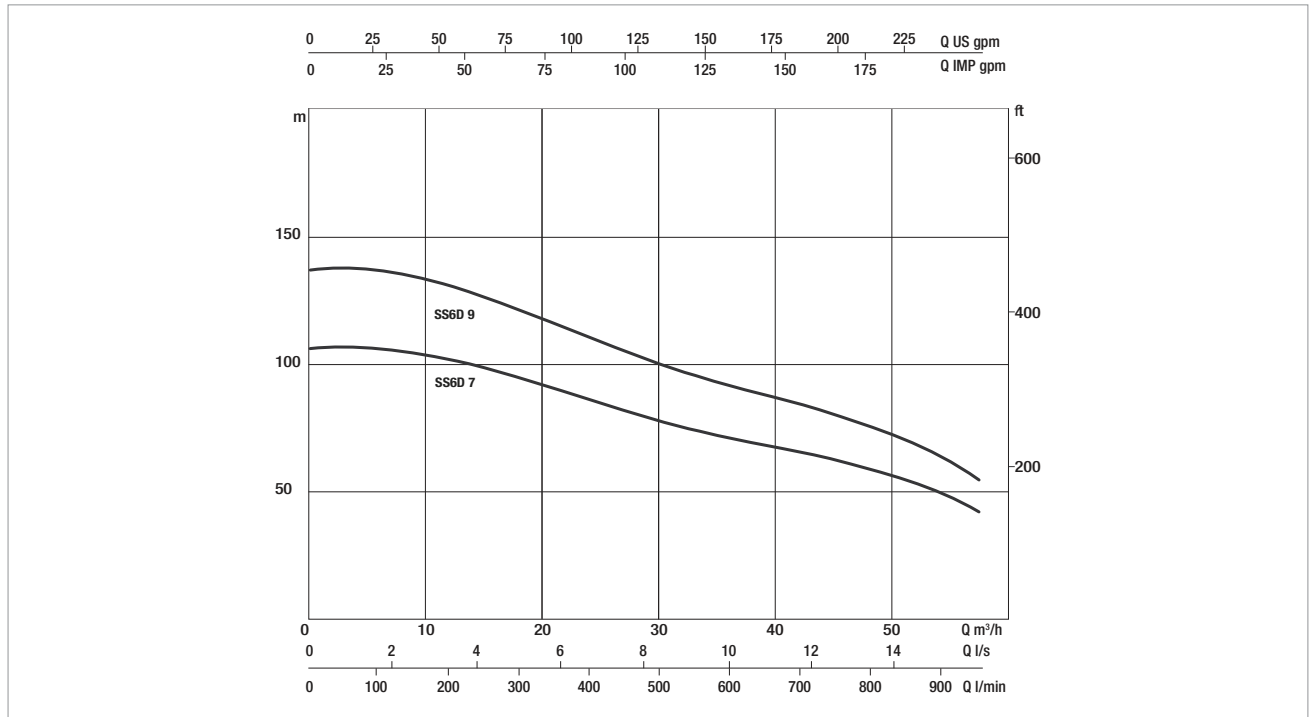

The performance curves are based on kinematic viscosity values = 1 mm²/s and density equal to 1000 kg/m³. Curve tolerance according to ISO 9906.

SETS WITH 1 SS6D SUBMERGED PUMP

MODEL	POWER INPUT 50 Hz	P2 NOMINAL		In (A)	CONTROL PANEL MODEL	MAX FLOW RATE m ³ /h	MAX OBTAINABLE PRESSURE	STANDARD PRESSURE (bar)
		kW	Hp					
1SS6D 7 T 400/50 EN 12845	3 x 400 50 Hz	11	15	25,5	EGE 11T SD 400/50-60	48	9.4	7.5
1SS6D 9 T 400/50 EN 12845	3 x 400 50 Hz	15	20	33,4	EGE 11T SD 400/50-60	48	12.6	10

SETS WITH 1 SS6D SUBMERGED PUMP + JOCKEY PUMP

MODEL	POWER INPUT 50 Hz	P2 NOMINAL		In (A)	CONTROL PANEL MODEL	MAX FLOW RATE m ³ /h	MAX OBTAINABLE PRESSURE	STANDARD PRESSURE (bar)
		kW	Hp					
1SS6D 7 T 400/50 EN 12845 - S4C 19T	3 x 400 50 Hz	11	15	25,5	EGE 11T SD 400/50-60	48	9.4	7.5
	3 x 400 50-60 Hz *	1.1 *	1.5 *	3.4 *	ED 1.5T (108320340) *	4.2 *	10.4 *	8 *
1SS6D 9 T 400/50 EN 12845 - S4C 25T	3 x 400 50 Hz	15	20	33,4	EGE 11T SD 400/50-60	48	12.6	10
	3 x 400 50-60 Hz *	1.5 *	2 *	4.4 *	ED 2.5T (108320350) *	4.2 *	13.7 *	11 *

* Jockey pump

SS6 SETS - UNI EN 12845 FIRE-FIGHTING SETS

SETS WITH 1 SUBMERGED PUMP

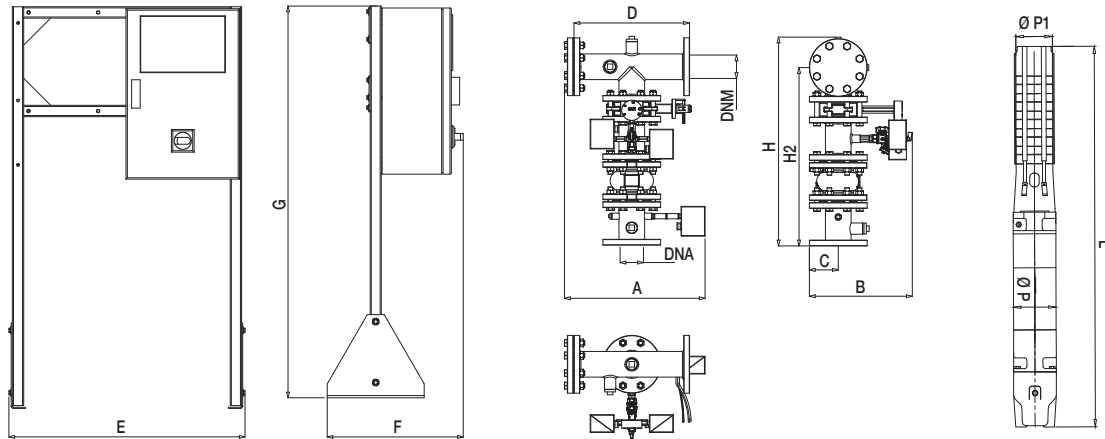

SETS WITH 1 SUBMERGED PUMP + JOCKEY PUMP

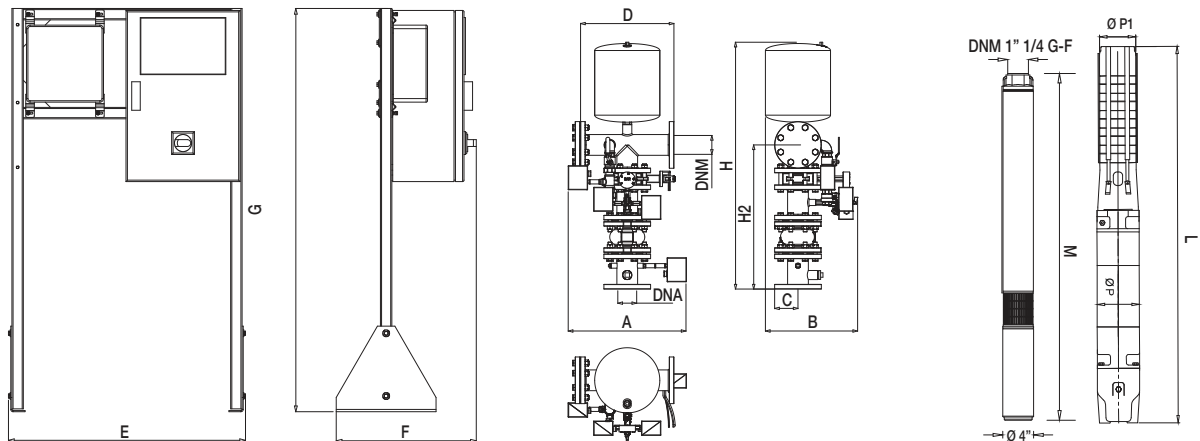

MODEL	A	B	C	D	E	F	G	H	H2	L	M	DNA	DNM	Ø P	Ø P1	PACKING (b x p x h)	WEIGHT kg
1SS6D 7 T 400/50 EN 12845	485	355	100	400	830	490	1415	725	615	1784	-	80	80	141	144	1000x1400x2200	197
1SS6D 9 T 400/50 EN 12845	485	355	100	400	830	490	1415	725	615	2063	-	80	80	141	144	1000x1400x2200	202
1SS6D 7 T 400/50 EN 12845 - S4C 19T	505	395	100	400	830	490	1415	1055	615	1784	1086	80	80	141	144	1000x1400x2200	242
1SS6D 9 T 400/50 EN 12845 - S4C 25T	505	395	100	400	830	490	1415	1055	615	2063	1343	80	80	141	144	1000x1400x2200	265

SS6 SETS - UNI EN 12845 FIRE-FIGHTING SETS

Pumped liquid temperature range: from 0°C to +40°C - Maximum ambient temperature: from 4°C to +40 °C - Maximum flow rate: 66 m³/h

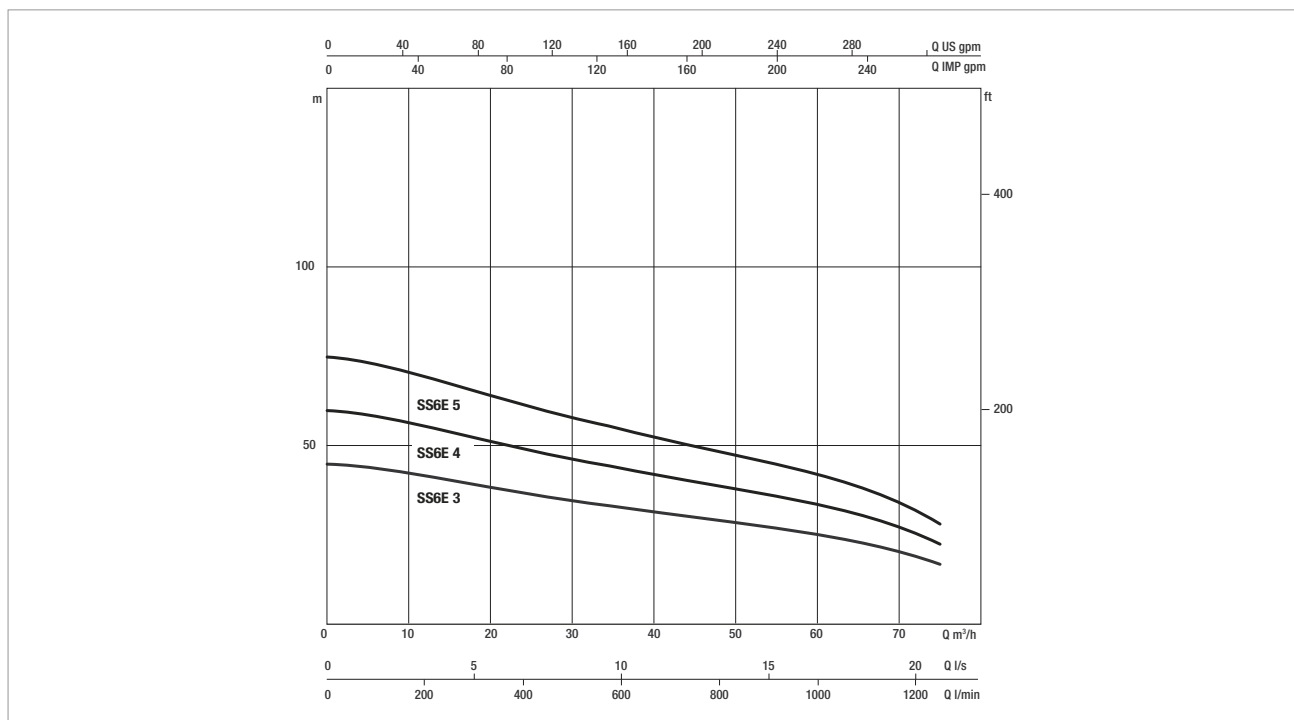

The performance curves are based on kinematic viscosity values = 1 mm²/s and density equal to 1000 kg/m³. Curve tolerance according to ISO 9906.

SETS WITH 1 SS6E SUBMERGED PUMP

MODEL	POWER INPUT 50 Hz	P2 NOMINAL		In (A)	CONTROL PANEL MODEL	MAX FLOW RATE m ³ /h	MAX OBTAINABLE PRESSURE	STANDARD PRESSURE (bar)
		kW	Hp					
1SS6E 3 T 400/50 EN 12845	3 x 400 50 Hz	5,5	7,5	14	EGE 5.5T 400/50-60	66	4	3
1SS6E 4 T 400/50 EN 12845	3 x 400 50 Hz	7,5	10	18	EGE 7.5T 400/50-60	66	5.2	4
1SS6E 5 T 400/50 EN 12845	3 x 400 50 Hz	9,2	12,5	22	EGE 11T SD 400/50-60	66	6.5	5

SETS WITH 1 SS6E SUBMERGED PUMP + JOCKEY PUMP

MODEL	POWER INPUT 50 Hz	P2 NOMINAL		In (A)	CONTROL PANEL MODEL	MAX FLOW RATE m ³ /h	MAX OBTAINABLE PRESSURE	STANDARD PRESSURE (bar)
		kW	Hp					
1SS6E 3 T 400/50 EN 12845 - S4C 13T	3 x 400 50 Hz	5.5	7.5	14	EGE 5.5T 400/50-60	66	4	3
	3 x 400 50-60 Hz *	0.75 *	1 *	2.4 *	ED 2.5T (108320350) *	4.2 *	7.1 *	6 *
1SS6E 4 T 400/50 EN 12845 - S4C 13T	3 x 400 50 Hz	7.5	10	18	EGE 7.5T 400/50-60	66	5.2	4
	3 x 400 50-60 Hz *	0.75 *	1 *	2.4 *	ED 2.5T (108320350) *	4.2 *	7.1 *	6 *
1SS6E 5 T 400/50 EN 12845 - S4C 19T	3 x 400 50 Hz	9.2	12.5	22	EGE 11T SD 400/50-60	66	6.5	5
	3 x 400 50-60 Hz *	0.75 *	1 *	2.4 *	ED 2.5T (108320350) *	4.2 *	7.1 *	6 *

* Jockey pump

SS6 SETS - UNI EN 12845 FIRE-FIGHTING SETS

SETS WITH 1 SUBMERGED PUMP

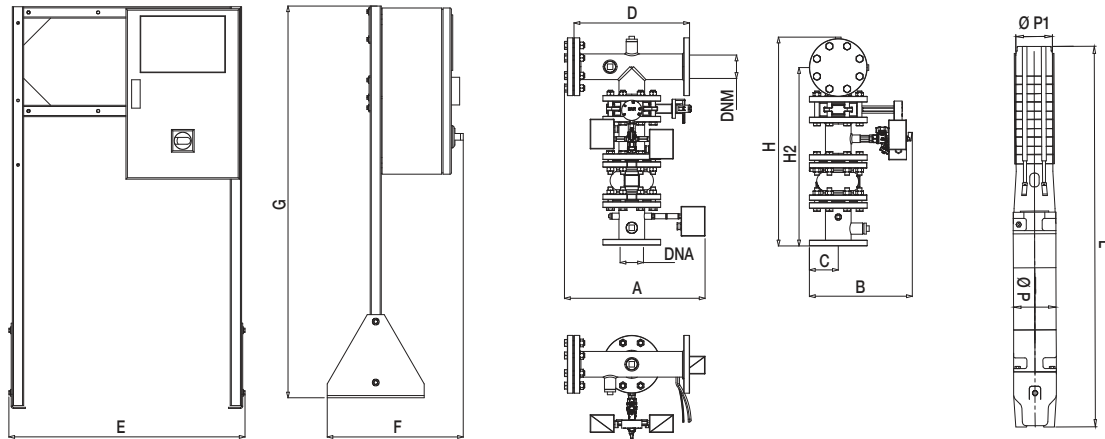

SETS WITH 1 SUBMERGED PUMP + JOCKEY PUMP

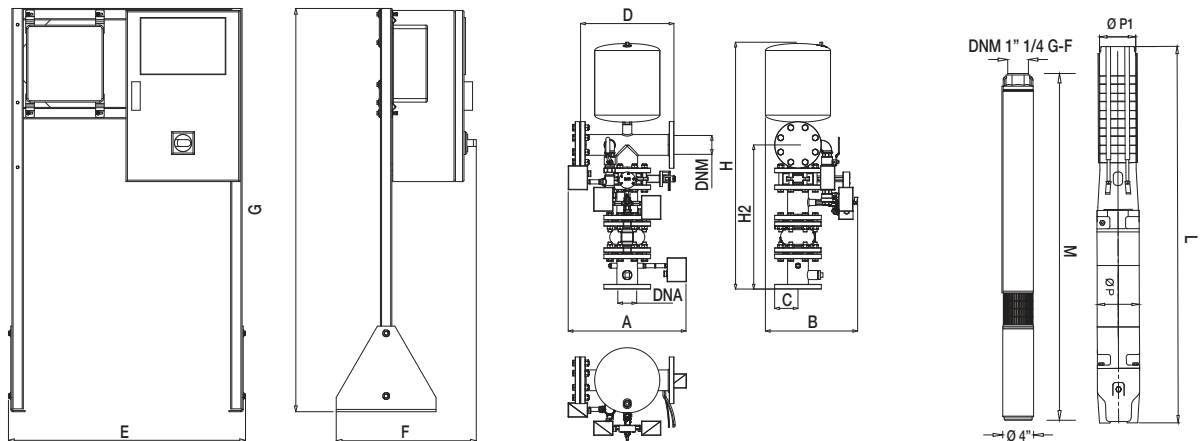

MODEL	A	B	C	D	E	F	G	H	H2	L	M	DNA	DNM	Ø P	Ø P1	PACKING (bpxh)	WEIGHT kg
1SS6E 3 T 400/50 EN 12845	485	355	100	400	830	490	1415	725	615	1237	-	80	80	141	144	1000x1400x2200	114
1SS6E 4 T 400/50 EN 12845	485	355	100	400	830	490	1415	725	615	1378	-	80	80	141	144	1000x1400x2200	117
1SS6E 5 T 400/50 EN 12845	485	355	100	400	830	490	1415	725	615	1515	-	80	80	141	144	1000x1400x2200	121
1SS6E 3 T 400/50 EN 12845 - S4C 13T	505	395	100	400	830	490	1415	1055	615	1237	871	80	80	141	144	1000x1400x2200	236
1SS6E 4 T 400/50 EN 12845 - S4C 13T	505	395	100	400	830	490	1415	1055	615	1378	871	80	80	141	144	1000x1400x2200	239
1SS6E 5 T 400/50 EN 12845 - S4C 19T	505	395	100	400	830	490	1415	1055	615	1515	871	80	80	141	144	1000x1400x2200	243

SS6 SETS - UNI EN 12845 FIRE-FIGHTING SETS

Pumped liquid temperature range: from 0°C to +40°C - Maximum ambient temperature: from 4°C to +40 °C - Maximum flow rate: 66 m³/h

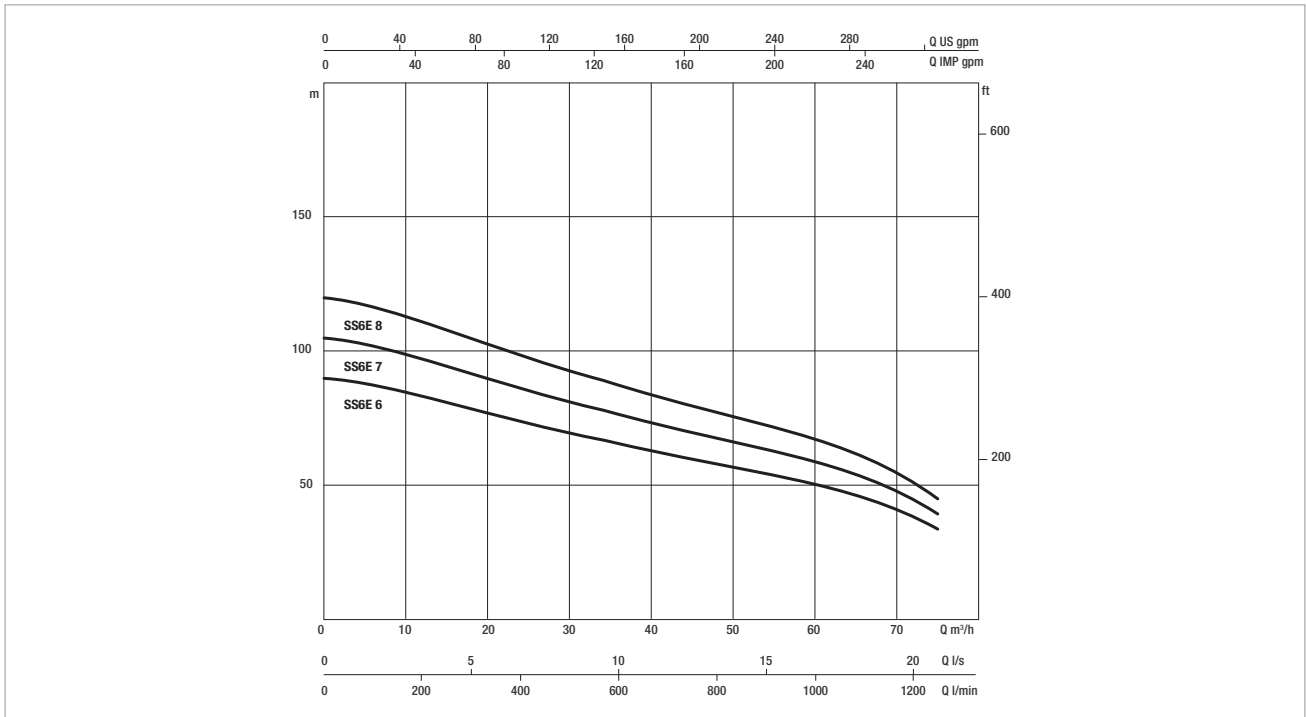

The performance curves are based on kinematic viscosity values = 1 mm²/s and density equal to 1000 kg/m³. Curve tolerance according to ISO 9906.

SETS WITH 1 SS6E SUBMERGED PUMP

MODEL	POWER INPUT 50 Hz	P2 NOMINAL		In (A)	CONTROL PANEL MODEL	MAX FLOW RATE m³/h	MAX OBTAINABLE PRESSURE	STANDARD PRESSURE (bar)
		kW	Hp					
1SS6E 6 T 400/50 EN 12845	3 x 400 50 Hz	11	15	25.5	EGE 11T SD 400/50-60	66	7.8	6
1SS6E 7 T 400/50 EN 12845	3 x 400 50 Hz	15	20	33.4	EGE 15T SD 400/50-60	66	10.4	8
1SS6E 8 T 400/50 EN 12845	3 x 400 50 Hz	15	20	33.4	EGE 15T SD 400/50-60	66	11.8	9.5

SETS WITH 1 SS6E SUBMERGED PUMP + JOCKEY PUMP

MODEL	POWER INPUT 50 Hz	P2 NOMINAL		In (A)	CONTROL PANEL MODEL	MAX FLOW RATE m³/h	MAX OBTAINABLE PRESSURE	STANDARD PRESSURE (bar)
		kW	Hp					
1SS6E 6 T 400/50 EN 12845 - S4C 19T	3 x 400 50 Hz	11	15	25.5	EGE 11T SD 400/50-60	66	7.8	6
	3 x 400 50-60 Hz *	1.1 *	1.5 *	3.4 *	ED 1.5T (108320340) *	4.2 *	10.4 *	8 *
1SS6E 7 T 400/50 EN 12845 - S4C 25T	3 x 400 50 Hz	15	20	33.4	EGE 15T SD 400/50-60	66	10.4	8
	3 x 400 50-60 Hz *	1.5 *	2 *	4.4 *	ED 2.5T (108320350) *	4.2 *	13.7 *	11 *
1SS6E 8 T 400/50 EN 12845 - S4C 25T	3 x 400 50 Hz	15	20	33.4	EGE 15T SD 400/50-60	66	11.8	9.5
	3 x 400 50-60 Hz *	1.5 *	2 *	4.4 *	ED 2.5T (108320350) *	4.2 *	13.7 *	11 *

* Jockey pump

SS6 SETS - UNI EN 12845 FIRE-FIGHTING SETS

SETS WITH 1 SUBMERGED PUMP

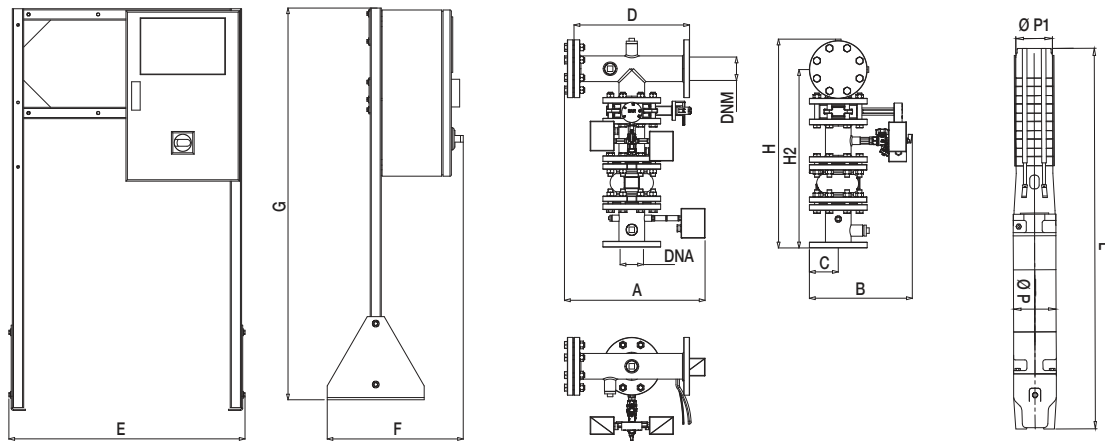

SETS WITH 1 SUBMERGED PUMP + JOCKEY PUMP

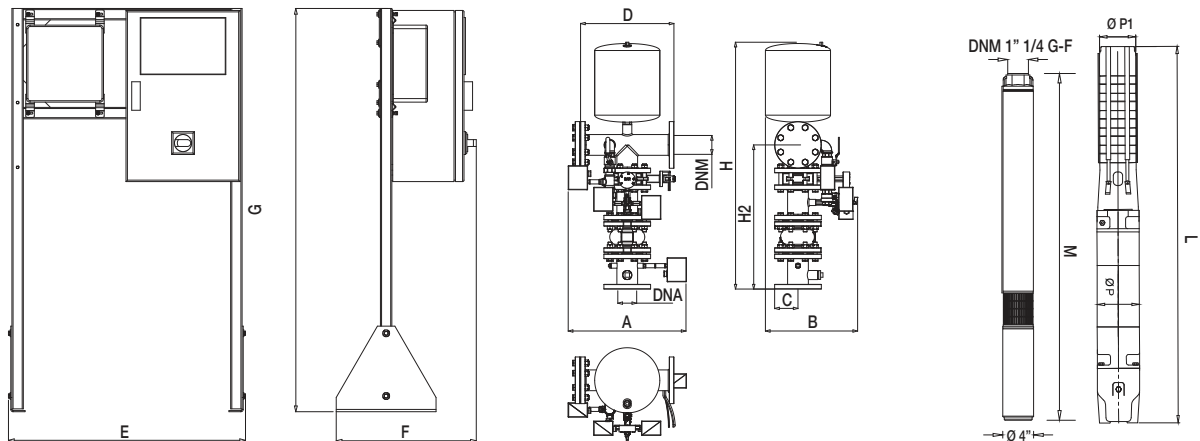

MODEL	A	B	C	D	E	F	G	H	H2	L	M	DNA	DNM	Ø P	Ø P1	PACKING (bpxh)	WEIGHT kg
1SS6E 6 T 400/50 EN 12845	485	355	100	400	830	490	1415	725	615	1672	-	80	80	141	144	1000x1400x2200	126
1SS6E 7 T 400/50 EN 12845	485	355	100	400	830	490	1415	725	615	1839	-	80	80	141	144	1000x1400x2200	150
1SS6E 8 T 400/50 EN 12845	485	355	100	400	830	490	1415	725	615	1951	-	80	80	141	144	1000x1400x2200	225
1SS6E 6 T 400/50 EN 12845 - S4C 19T	505	395	100	400	830	490	1415	1055	615	1672	1086	80	80	141	144	1000x1400x2200	248
1SS6E 7 T 400/50 EN 12845 - S4C 25T	505	395	100	400	830	490	1415	1055	615	1839	1343	80	80	141	144	1000x1400x2200	158
1SS6E 8 T 400/50 EN 12845 - S4C 25T	505	395	100	400	830	490	1415	1055	615	1951	1343	80	80	141	144	1000x1400x2200	245

SS7 SETS - UNI EN 12845 FIRE-FIGHTING SETS

Pumped liquid temperature range: from 0°C to +40°C - Maximum ambient temperature: from 4°C to +40 °C - Maximum flow rate: 100 m³/h

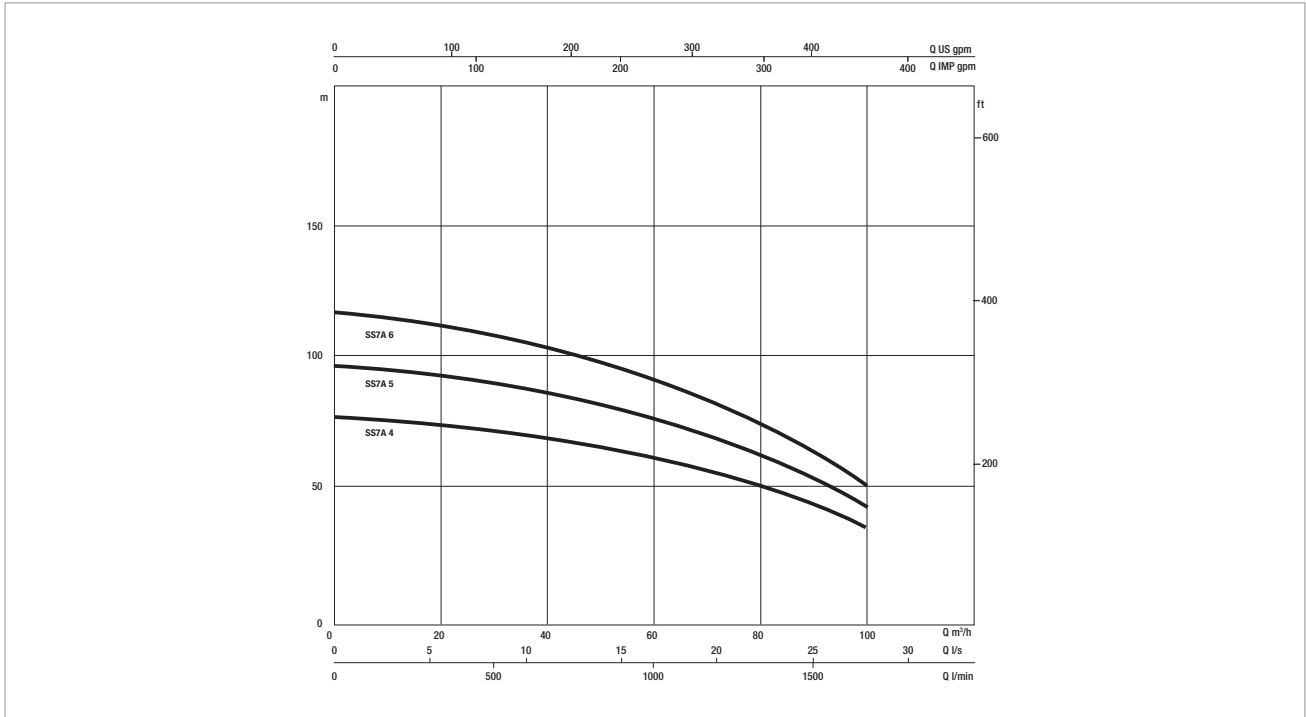

The performance curves are based on kinematic viscosity values = 1 mm²/s and density equal to 1000 kg/m³. Curve tolerance according to ISO 9906.

SETS WITH 1 SS7A SUBMERGED PUMP

MODEL	POWER INPUT 50 Hz	P2 NOMINAL		In (A)	CONTROL PANEL MODEL	MAX FLOW RATE m³/h	MAX OBTAINABLE PRESSURE	STANDARD PRESSURE (bar)
		kW	Hp					
1SS7A 4 T 400/50 EN 12845	3 x 400 50 Hz	15	20	33.4	EGE 18.5T SD 400/50-60	100	7.4	6
1SS7A 5 T 400/50 EN 12845	3 x 400 50 Hz	18.5	25	41	EGE 22T SD 400/50-60	100	10	8
1SS7A 6 T 400/50 EN 12845	3 x 400 50 Hz	22	30	47	EGE 22T SD 400/50-60	100	12.6	10

SETS WITH 1 SS7A SUBMERGED PUMP + JOCKEY PUMP

MODEL	POWER INPUT 50 Hz	P2 NOMINAL		In (A)	CONTROL PANEL MODEL	MAX FLOW RATE m³/h	MAX OBTAINABLE PRESSURE	STANDARD PRESSURE (bar)
		kW	Hp					
1SS7A 4 T 400/50 EN 12845 - S4C 19T	3x400 50 Hz	15	20	33.4	EGE 18.5T SD 400/50-60	100	7.4	6
	3x400 50-60 Hz *	1.1 *	1.5 *	3.4 *	ED 1.5T (108320340) *	4.2 *	10.4 *	8 *
1SS7A 5 T 400/50 EN 12845 - S4C 19T	3x400 50 Hz	18.5	25	41	EGE 22T SD 400/50-60	100	10	8
	3x400 50-60 Hz *	1.1 *	1.5 *	3.4 *	ED 1.5T (108320340) *	4.2 *	10.4 *	8 *
1SS7A 6 T 400/50 EN 12845 - S4C 25T	3x400 50 Hz	22	30	47	EGE 22T SD 400/50-60	100	12.6	10
	3x400 50-60 Hz *	1.5 *	2 *	4.4 *	ED 2.5T (108320350) *	4.2 *	13.7 *	11 *

* Jockey pump

SS7 SETS - UNI EN 12845 FIRE-FIGHTING SETS

SETS WITH 1 SUBMERGED PUMP

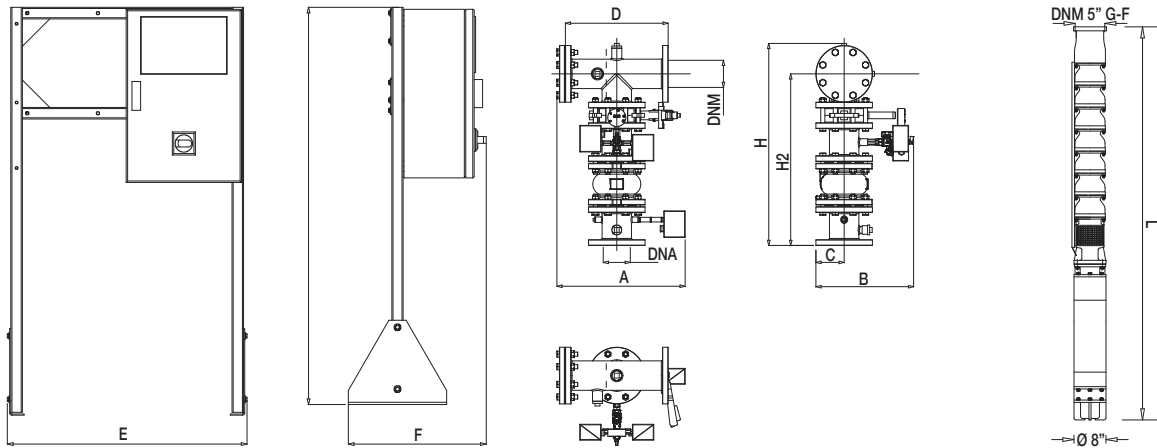

SETS WITH 1 SUBMERGED PUMP + JOCKEY PUMP

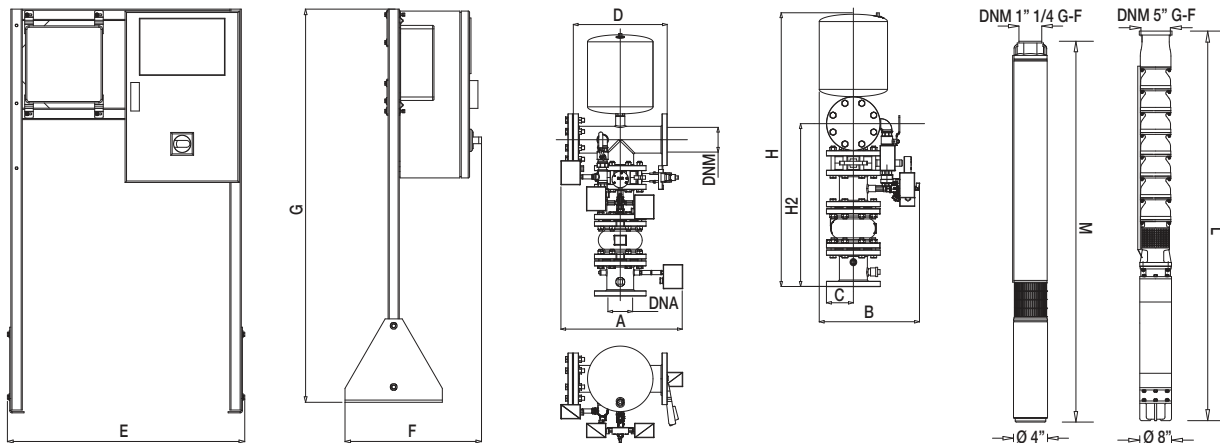

MODEL	A	B	C	D	E	F	G	H	H2	L	M	DNA	DNM	Ø P	Ø P1	PACKING (bpxh)	WEIGHT kg
1SS7A 4 T 400/50 EN 12845	500	380	110	400	830	490	1415	785	665	1740	-	100	100	141	172	1000x1400x2200	260
1SS7A 5 T 400/50 EN 12845	500	380	110	400	830	490	1415	785	665	1943	-	100	100	141	172	1000x1400x2200	265
1SS7A 6 T 400/50 EN 12845	500	380	110	400	830	490	1415	785	665	2131	-	100	100	141	172	1000x1400x2200	278
1SS7A 4 T 400/50 EN 12845 - S4C 19T	520	410	110	400	830	490	1415	1120	665	1740	1086	100	100	141	172	1000x1400x2200	280
1SS7A 5 T 400/50 EN 12845 - S4C 19T	520	410	110	400	830	490	1415	1120	665	1943	1086	100	100	141	172	1000x1400x2200	285
1SS7A 6 T 400/50 EN 12845 - S4C 25T	520	410	110	400	830	490	1415	1120	665	2131	1343	100	100	141	172	1000x1400x2200	298

SS7 SETS - UNI EN 12845 FIRE-FIGHTING SETS

Pumped liquid temperature range: from 0°C to +40°C - Maximum ambient temperature: from 4°C to +40 °C - Maximum flow rate: 120 m³/h

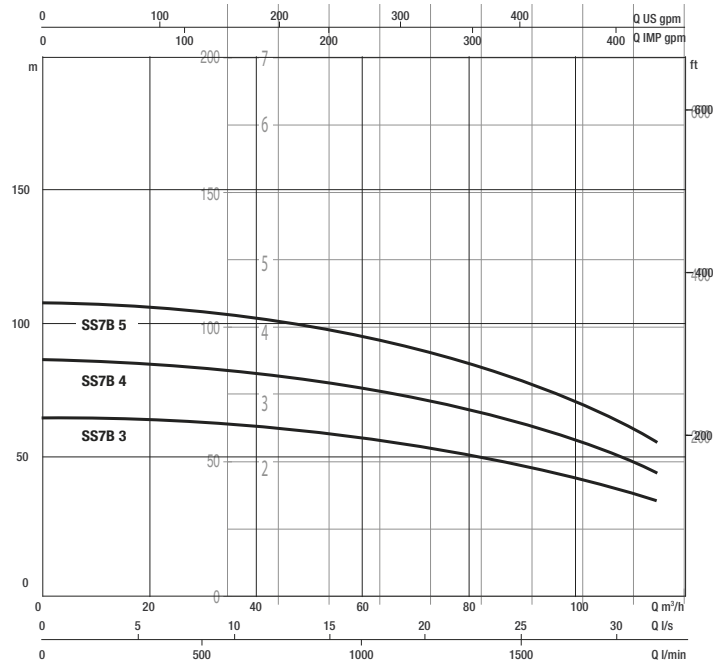

The performance curves are based on kinematic viscosity values = 1 mm²/s and density equal to 1000 kg/m³. Curve tolerance according to ISO 9906.

SETS WITH 1 SS7B SUBMERGED PUMP

MODEL	POWER INPUT 50 Hz	P2 NOMINAL		In (A)	CONTROL PANEL MODEL	MAX FLOW RATE m³/h	MAX OBTAINABLE PRESSURE	STANDARD PRESSURE (bar)
		kW	Hp					
1SS7B 3 T 400/50 EN 12845	3 x 400 50 Hz	15	20	33,4	EGE 22T SD 400/50-60	120	7.9	6
1SS7B 4 T 400/50 EN 12845	3 x 400 50 Hz	22	30	47	EGE 22T SD 400/50-60	120	10.6	8.5
1SS7B 5 T 400/50 EN 12845	3 x 400 50 Hz	30	40	61.5	EGE 30T SD 400/50-60	120	13.4	10.5

SETS WITH 1 SS7B SUBMERGED PUMP + JOCKEY PUMP

MODEL	POWER INPUT 50 Hz	P2 NOMINAL		In (A)	CONTROL PANEL MODEL	MAX FLOW RATE m³/h	MAX OBTAINABLE PRESSURE	STANDARD PRESSURE (bar)
		kW	Hp					
1SS7B 3 T 400/50 EN 12845 - S4C 19T	3x400 50 Hz	15	20	33,4	EGE 22T SD 400/50-60	120	7.9	6
	3x400 50-60 Hz *	1.1 *	1.5 *	3.4 *	ED 1.5T (108320340) *	4.2 *	10.4 *	8 *
1SS7B 4 T 400/50 EN 12845 - S4C 25T	3x400 50 Hz	22	30	47	EGE 22T SD 400/50-60	120	10.6	8.5
	3x400 50-60 Hz *	1.5 *	2 *	4.4 *	ED 2.5T (108320350) *	4.2 *	13.7 *	11 *
1SS7B 5 T 400/50 EN 12845 - S4C 25T	3x400 50 Hz	30	40	61.5	EGE 30T SD 400/50-60	120	13.4	10.5
	3x400 50-60 Hz *	1.5 *	2 *	4.4 *	ED 2.5T (108320350) *	4.2 *	13.7 *	11 *

* Jockey pump

SS7 SETS - UNI EN 12845 FIRE-FIGHTING SETS

SETS WITH 1 SUBMERGED PUMP

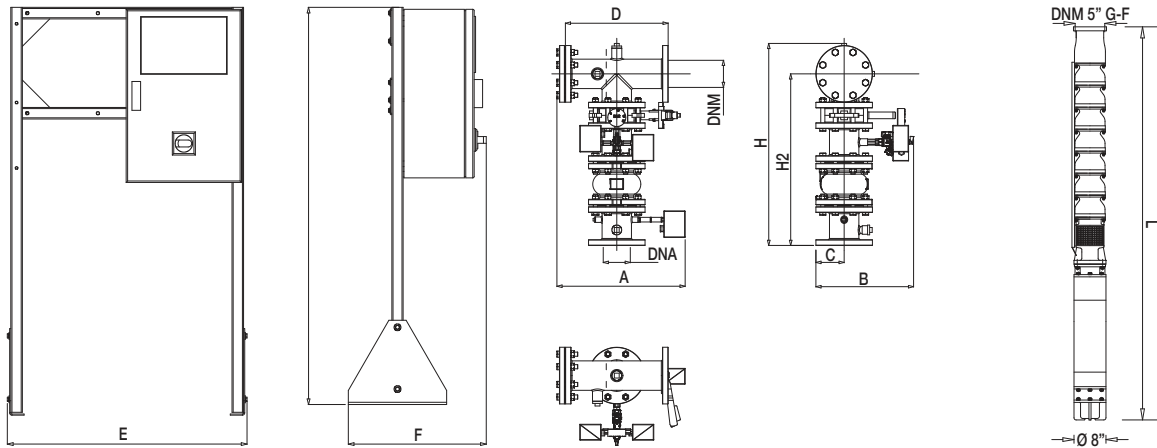

SETS WITH 1 SUBMERGED PUMP + JOCKEY PUMP

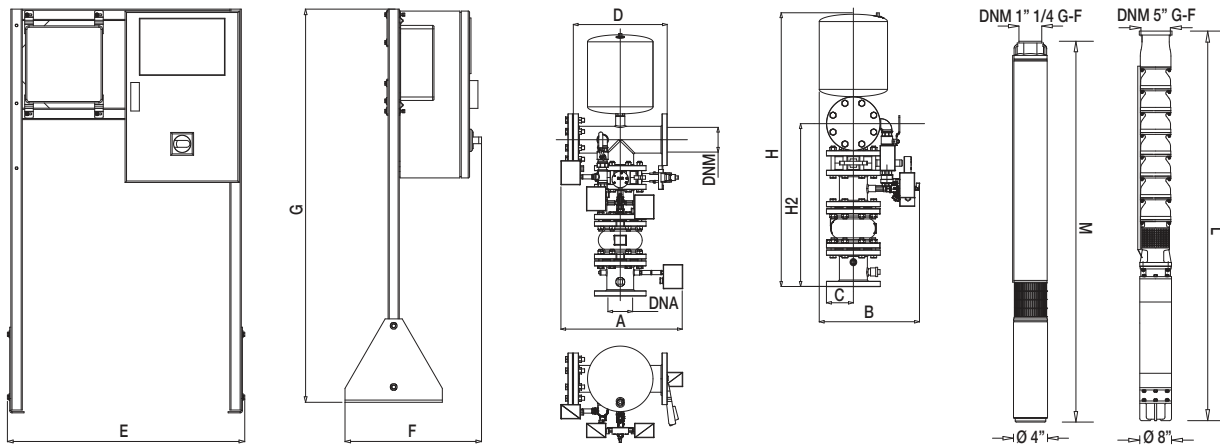

MODEL	A	B	C	D	E	F	G	H	H2	L	M	DNA	DNM	Ø P	Ø P1	PACKING (bpxh)	WEIGHT kg
1SS7B 3 T 400/50 EN 12845	500	380	110	400	830	490	1415	785	665	1612	-	100	100	141	172	1000x1400x2200	275
1SS7B 4 T 400/50 EN 12845	500	380	110	400	830	490	1415	785	665	1875	-	100	100	141	172	1000x1400x2200	280
1SS7B 5 T 400/50 EN 12845	500	380	110	400	830	490	1415	785	665	2133	-	100	100	141	172	1000x1400x2200	285
1SS7B 3 T 400/50 EN 12845 - S4C 19T	520	410	110	400	830	490	1415	1120	665	1612	1086	100	100	141	172	1000x1400x2200	295
1SS7B 4 T 400/50 EN 12845 - S4C 25T	520	410	110	400	830	490	1415	1120	665	1875	1343	100	100	141	172	1000x1400x2200	300
1SS7B 5 T 400/50 EN 12845 - S4C 25T	520	410	110	400	830	490	1415	1120	665	2133	1343	100	100	141	172	1000x1400x2200	305

SS8 SETS - UNI EN 12845 FIRE-FIGHTING SETS

Pumped liquid temperature range: from 0°C to +40°C - Maximum ambient temperature: from 4°C to +40 °C - Maximum flow rate: 140 m³/h

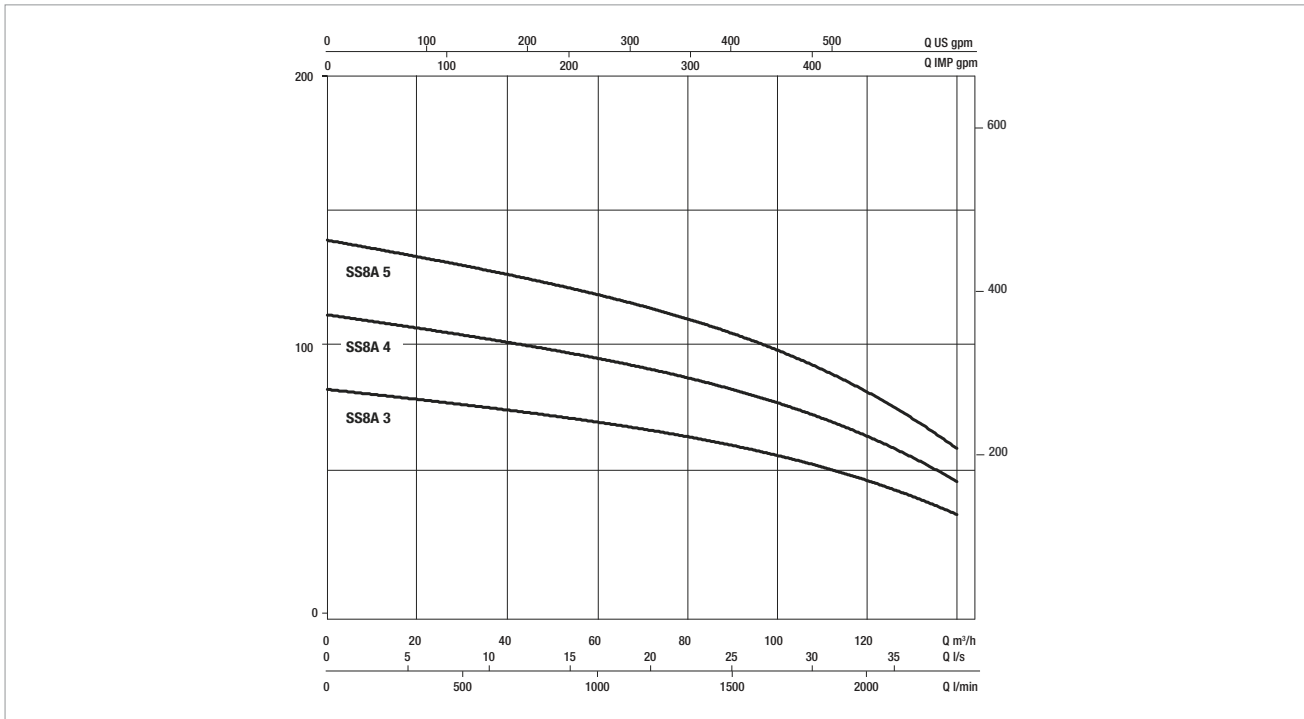

The performance curves are based on kinematic viscosity values = 1 mm²/s and density equal to 1000 kg/m³. Curve tolerance according to ISO 9906.

SETS WITH 1 SS8A SUBMERGED PUMP

MODEL	POWER INPUT 50 Hz	P2 NOMINAL		In (A)	CONTROL PANEL MODEL	MAX FLOW RATE m³/h	MAX OBTAINABLE PRESSURE	STANDARD PRESSURE (bar)
		kW	Hp					
1SS8A 3 T 400/50 EN 12845	3 x 400 50 Hz	22	30	47	EGE 22T SD 400/50-60	140	7.4	6
1SS8A 4 T 400/50 EN 12845	3 x 400 50 Hz	30	40	61.5	EGE 30T SD 400/50-60	140	10	8
1SS8A 5 T 400/50 EN 12845	3 x 400 50 Hz	37	50	79.3	EGE 37T SD 400/50-60	140	12.7	10

SETS WITH 1 SS8A SUBMERGED PUMP + JOCKEY PUMP

MODEL	POWER INPUT 50 Hz	P2 NOMINAL		In (A)	CONTROL PANEL MODEL	MAX FLOW RATE m³/h	MAX OBTAINABLE PRESSURE	STANDARD PRESSURE (bar)
		kW	Hp					
1SS8A 3 T 400/50 EN 12845 - S4C 19T	3x400 50 Hz	22	30	47	EGE 22T SD 400/50-60	140	7.4	6
	3x400 50-60 Hz *	1.1 *	1.5 *	3.4 *	ED 1.5T (108320340) *	4.2 *	10.4 *	8 *
1SS8A 4 T 400/50 EN 12845 - S4C 19T	3x400 50 Hz	30	40	61.5	EGE 30T SD 400/50-60	140	10	8
	3x400 50-60 Hz *	1.1 *	1.5 *	3.4 *	ED 1.5T (108320340) *	4.2 *	10.4 *	8 *
1SS8A 5 T 400/50 EN 12845 - S4C 25T	3x400 50 Hz	37	50	79.3	EGE 37T SD 400/50-60	140	12.7	10
	3x400 50-60 Hz *	1.5 *	2 *	4.4 *	ED 2.5T (108320350) *	4.2 *	13.7 *	11 *

* Jockey pump

SS8 SETS - UNI EN 12845 FIRE-FIGHTING SETS

SETS WITH 1 SUBMERGED PUMP

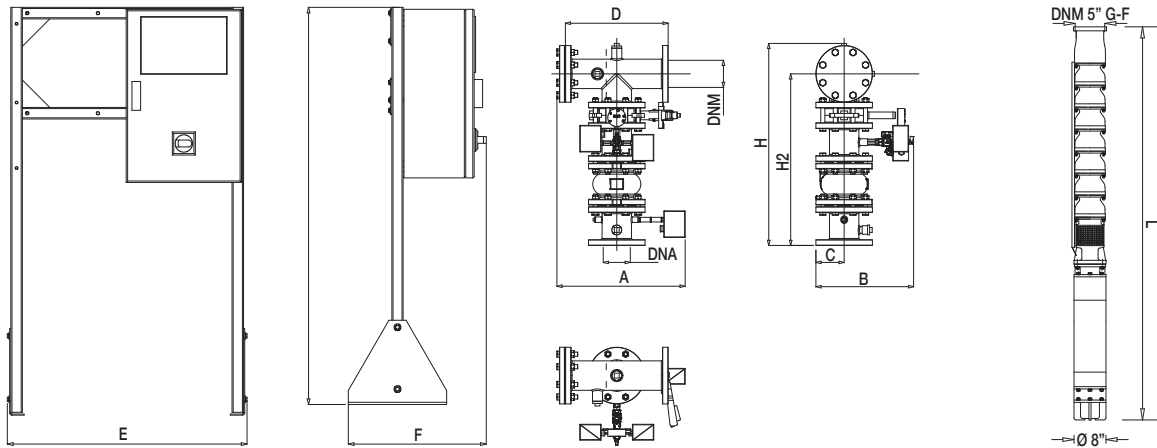

SETS WITH 1 SUBMERGED PUMP + JOCKEY PUMP

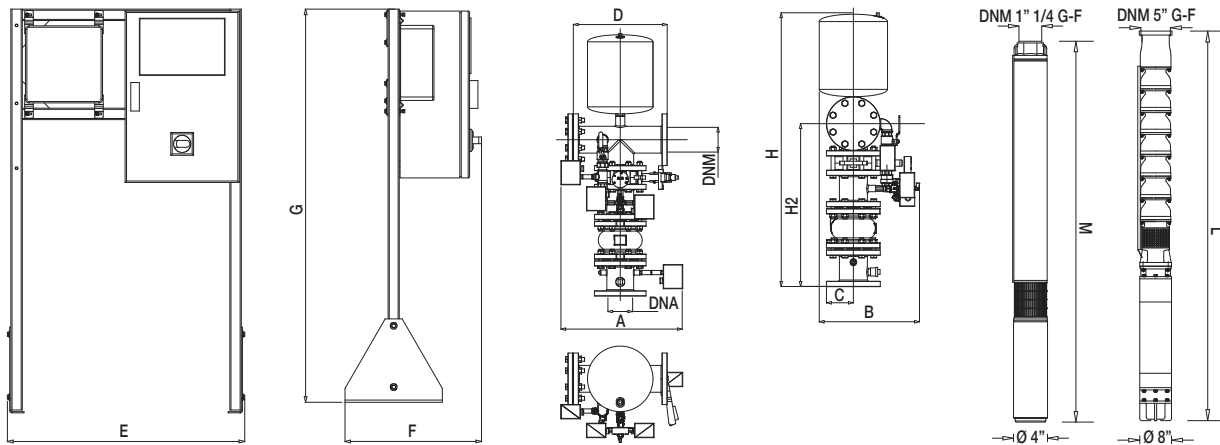

MODEL	A	B	C	D	E	F	G	H	H2	L	M	DNA	DNM	Ø P	Ø P1	PACKING (bpxh)	WEIGHT kg
1SS8A 3 T 400/50 EN 12845	500	380	110	400	830	490	1415	785	665	1917	-	100	100	141	213	1000x1400x2200	244
1SS8A 4 T 400/50 EN 12845	500	380	110	400	830	490	1415	785	665	2203	-	100	100	141	213	1000x1400x2200	252
1SS8A 5 T 400/50 EN 12845	500	380	110	400	830	490	1415	785	665	2489	-	100	100	141	213	1000x1400x2200	260
1SS8A 3 T 400/50 EN 12845 - S4C 19T	520	410	110	400	830	490	1415	1120	665	1917	1086	100	100	141	213	1000x1400x2200	264
1SS8A 4 T 400/50 EN 12845 - S4C 19T	520	410	110	400	830	490	1415	1120	665	2203	1086	100	100	141	213	1000x1400x2200	272
1SS8A 5 T 400/50 EN 12845 - S4C 25T	520	410	110	400	830	490	1415	1120	665	2489	1343	100	100	141	213	1000x1400x2200	290

SS8 SETS - UNI EN 12845 FIRE-FIGHTING SETS

Pumped liquid temperature range: from 0°C to +40°C - Maximum ambient temperature: from 4°C to +40 °C - Maximum flow rate: 160 m³/h

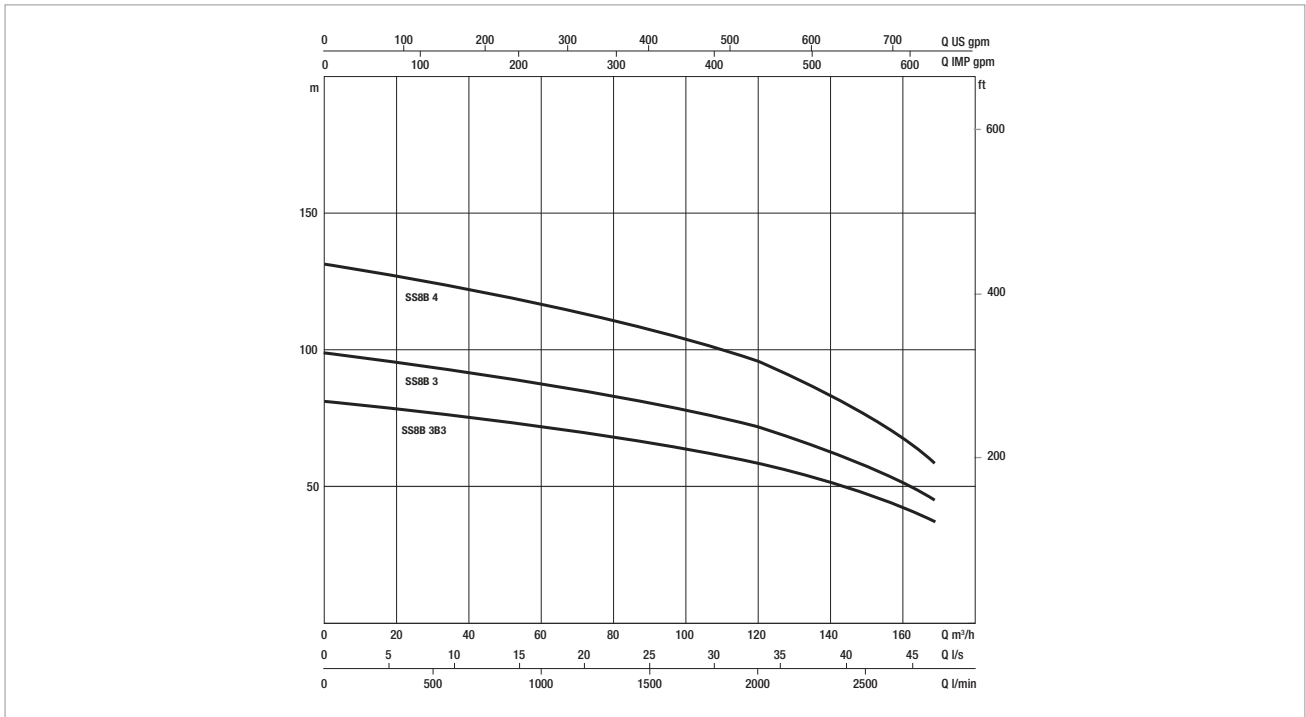

The performance curves are based on kinematic viscosity values = 1 mm²/s and density equal to 1000 kg/m³. Curve tolerance according to ISO 9906.

SETS WITH 1 SS8B SUBMERGED PUMP

MODEL	POWER INPUT 50 Hz	P2 NOMINAL		In (A)	MODEL CONTROL PANEL	MAX FLOW RATE m³/h	MAX OBTAINABLE PRESSURE	STANDARD PRESSURE (bar)
		kW	Hp					
1SS8B 3B3 T 400/50 EN 12845	3 x 400 50 Hz	30	40	61.5	EGE 30T SD 400/50-60	160	7.7	6
1SS8B 3 T 400/50 EN 12845	3 x 400 50 Hz	37	50	79.3	EGE 37T SD 400/50-60	160	10.3	8
1SS8B 4 T 400/50 EN 12845	3 x 400 50 Hz	45	60	92	EGE 45T SD 400/50-60	160	13.1	10.5

SETS WITH 1 SS8B SUBMERGED PUMP + JOCKEY PUMP

MODEL	POWER INPUT 50 Hz	P2 NOMINAL		In (A)	CONTROL PANEL MODEL	MAX FLOW RATE m³/h	MAX OBTAINABLE PRESSURE	STANDARD PRESSURE (bar)
		kW	Hp					
1SS8B 3B3 T 400/50 EN 12845 - S4C 19T	3 x 400 50 Hz	30	40	61.5	EGE 30T SD 400/50-60	160	7.7	6
	3x400 50-60 Hz *	1.1 *	1.5 *	3.4 *	ED 1.5T (108320340) *	4.2 *	10.4 *	8 *
1SS8B 3 T 400/50 EN 12845 - S4C 25T	3x400 50 Hz	37	50	79.3	EGE 37T SD 400/50-60	160	10.3	8
	3x400 50-60 Hz *	1.5 *	2 *	4.4 *	ED 2.5T (108320350) *	4.2 *	13.7 *	11 *
1SS8B 4 T 400/50 EN 12845 - S4C 25T	3x400 50 Hz	45	60	92	EGE 45T SD 400/50-60	160	13.1	10,5
	3x400 50-60 Hz *	1.5 *	2 *	4.4 *	ED 2.5T (108320350) *	4.2 *	13.7 *	11 *

* Jockey pump

SS8 SETS - UNI EN 12845 FIRE-FIGHTING SETS

SETS WITH 1 SUBMERGED PUMP

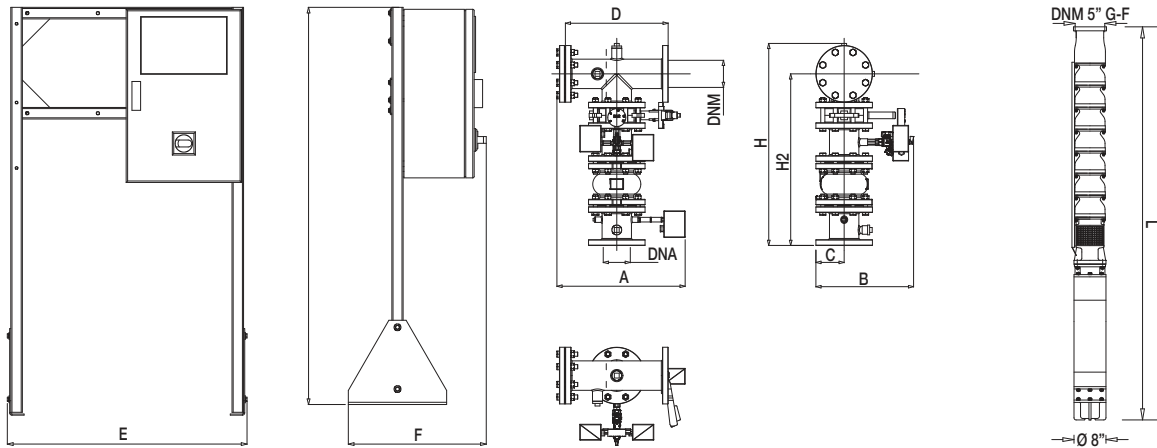

SETS WITH 1 SUBMERGED PUMP + JOCKEY PUMP

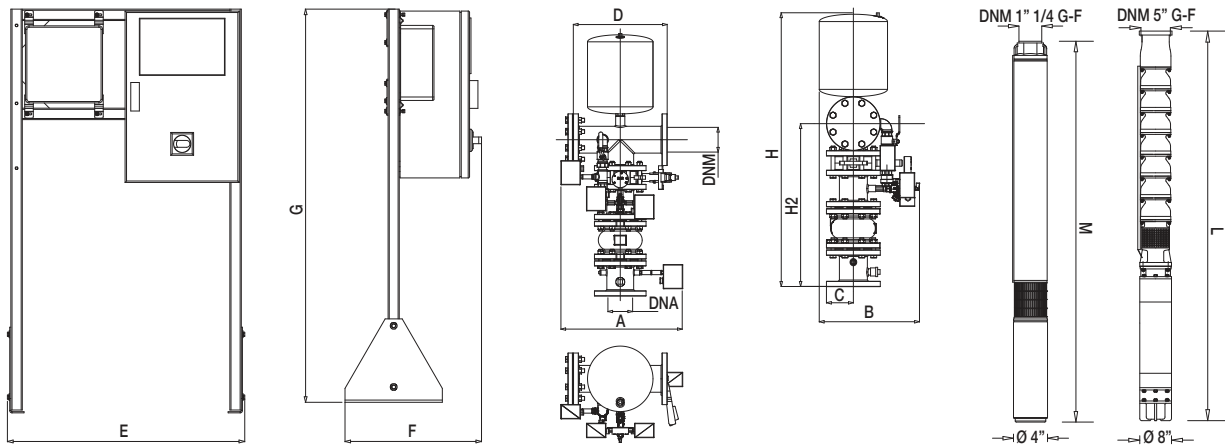

MODEL	A	B	C	D	E	F	G	H	H2	L	M	DNA	DNM	Ø P	Ø P1	PACKING (bpxh)	WEIGHT kg
1SS8B 3B3 T 400/50 EN 12845	500	380	110	400	830	490	1415	785	665	2047	-	100	100	141	213	1000x1400x2200	380
1SS8B 3 T 400/50 EN 12845	500	380	110	400	830	490	1415	785	665	2177	-	100	100	141	213	1000x1400x2200	390
1SS8B 4 T 400/50 EN 12845	500	380	110	400	830	490	1415	785	665	2423	-	100	100	141	213	1000x1400x2200	400
1SS8B 3B3 T 400/50 EN 12845 - S4C 19T	520	410	110	400	830	490	1415	1120	665	2047	1086	100	100	141	213	1000x1400x2200	400
1SS8B 3 T 400/50 EN 12845 - S4C 25T	520	410	110	400	830	490	1415	1120	665	2177	1343	100	100	141	213	1000x1400x2200	410
1SS8B 4 T 400/50 EN 12845 - S4C 25T	520	410	110	400	830	490	1415	1120	665	2423	1343	100	100	141	213	1000x1400x2200	420