

# MULTI INOX

## SELF-PRIMING, MULTISTAGE HORIZONTAL ELECTRIC PUMPS



### TECHNICAL DATA

**Operating range:**

capacity up to 90 l/min; head up to 59 m.

**Liquid temperature range:**

for domestic use: from +35°C to +35°C

for other use: from 0°C to +40°C

**Liquid quality requirements:** clean, free from solid or abrasive contaminants, non-viscous, non-aggressive, uncrystallised and chemically neutral.

**Maximum suction depth:** 8 metres

**Maximum ambient temperature:** +40°C

**Protection rating:** IPX4

**Insulation class:** F

**Installation:** fixed or portable in a horizontal position.

**Special executions on request:** alternative voltages and/or frequencies.

### APPLICATIONS

Multi-stage, self priming centrifugal pump with horizontal shaft, with excellent suction capacity even in the presence of air bubbles, featuring extremely quiet operation suitable for domestic water supply and pressurisation, irrigation of gardens and general water movement.

### FEATURES

Pump sleeve in stainless steel. Pressure and suction body and motor support in technopolymer. Impeller in AISI 304 stainless steel, diffuser bodies and diffuser in technopolymer. Carbon/ceramic mechanical seal. Rotor shaft in AISI 304 stainless steel. Single phase, asynchronous, continuous service motor. Incorporated thermo-amperometric protection and permanently inserted capacitor.

### MATERIALS

N°	PARTS*	MATERIALS
1	SUCTION FLANGE	TECHNOPOLYMER
2	INSERT	NICKLED BRASS
3	NUT	A2 – UNI7474 STAINLESS STEEL
4	WASHER	A2 STAINLESS STEEL
5	OR GASKET	NBR
6	COUNTERFLANGE	TECHNOPOLYMER
7	OR GASKET	NBR
8	DIFFUSER	TECHNOPOLYMER
9	IMPELLER	AISI 304 STAINLESS STEEL
10	ROTOR SHAFT	AISI 416 STAINLESS STEEL UNI EN 10088-1 X12CrS13
11	WASHER	A2 STAINLESS STEEL
12	SEEGER RING	AISI 316 STAINLESS STEEL
13	MECHANICAL SEAL	SILICON - VITON
14	COUNTERFACE	STEA/NBR
15	BODY	TECHNOPOLYMER
16	INSERT	NICKLED BRASS

\* In contact with liquid

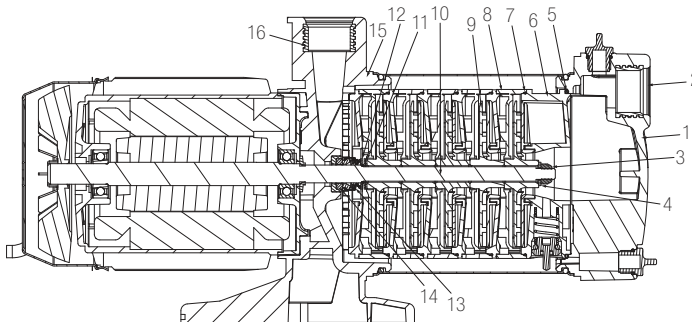

# MULTI INOX

## SELF-PRIMING, MULTISTAGE HORIZONTAL ELECTRIC PUMPS

### PERFORMANCE RANGE

The performance curves are based on kinematic viscosity values = 1 mm<sup>2</sup>/s and density equivalent to 1000 kg/m<sup>3</sup>. Curve tolerance according to ISO 9906.

### GRAPHIC SELECTION TABLE

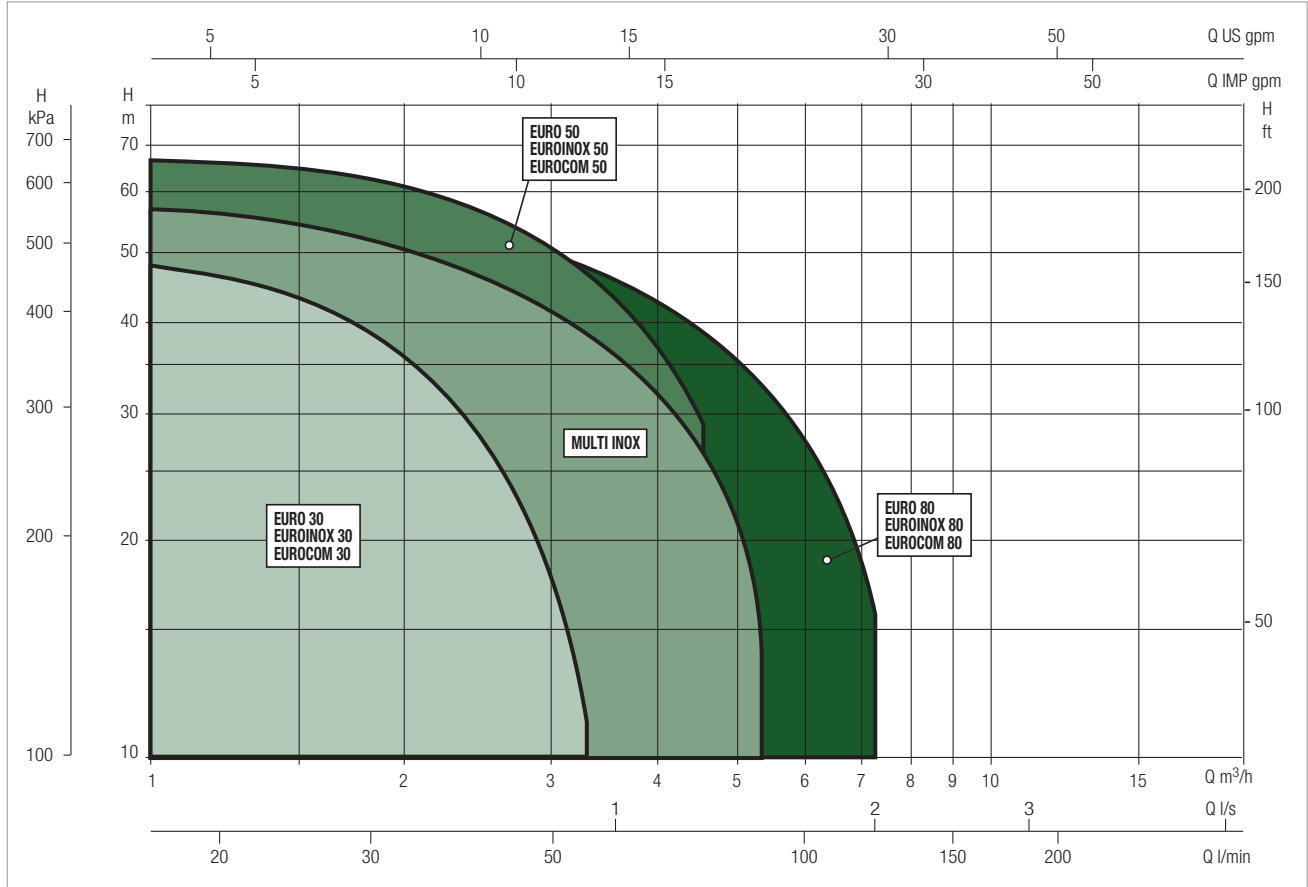

### MULTI INOX SELECTION TABLE

MODEL	Q=m <sup>3</sup> /h	0	0.6	1.2	1.8	2.4	3.0	3.6	4.2	4.8	5.4
	Q=l/min	0	10	20	30	40	50	60	70	80	90
MULTI INOX 3 M	H (m)	33	32	30	29	27	22	19	14	10	5
MULTI INOX 4 M		46	45	43	40	38	33	28	22	16	9
MULTI INOX 5 M		59	58	56	53	49	45	38	32	25	13

# MULTI INOX - SELF-PRIMING MULTI-STAGE, HORIZONTAL ELECTRIC PUMPS FOR DOMESTIC WATER SUPPLY

Liquid temperature range pumped: from 0 °C to +35 °C - Maximum ambient temperature: +40°C

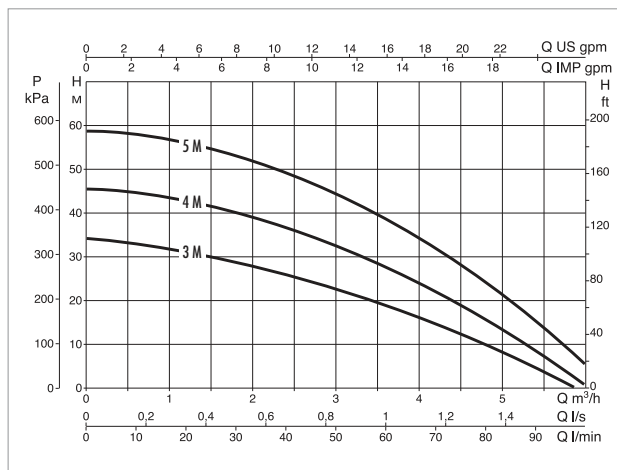
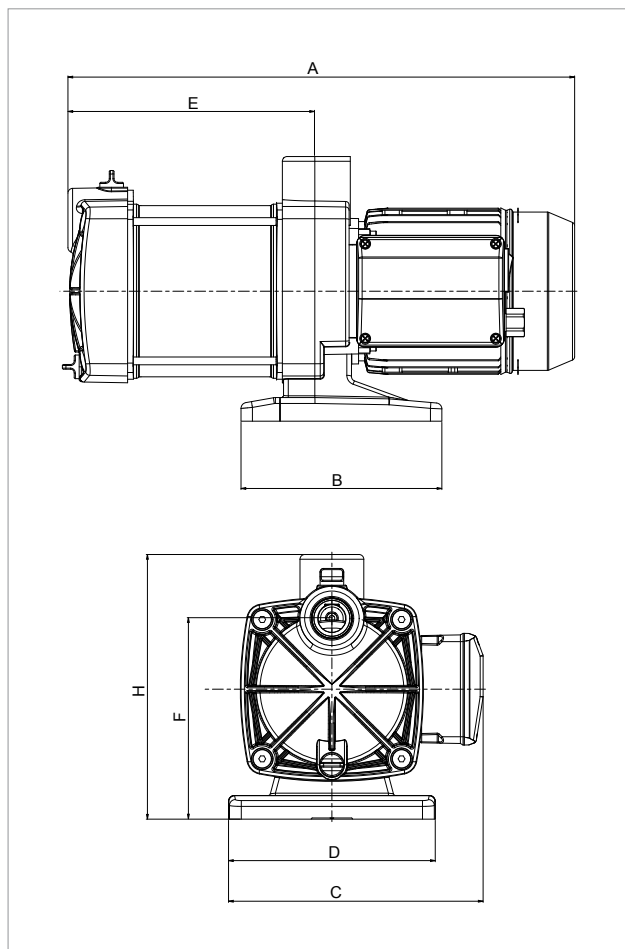

The performance curves are based on the kinematic viscosity values = 1 mm<sup>2</sup>/s and density equivalent to 1000 kg/m<sup>3</sup>. Curve tolerance according to ISO 9906.

MODEL	ELECTRICAL DATA							
	N° IMPELLER	POWER SUPPLY 50 Hz	P1 MAX KW	P2 NOMINAL		In A	CAPACITOR	
				kW	HP		µF	Vc
MULTI INOX 3 M	3	1x220-240 V ~	0.80	0.55	0.75	3.7	12.5	450
MULTI INOX 4 M	4	1x220-240 V ~	1.00	0.75	1	4.5	16	450
MULTI INOX 5 M	5	1x220-240 V ~	1.25	1	1.36	5.5	20	450

MODEL	A	B	C	D	E	F	H	DNA GAS	DNM GAS	PACK DIMENSIONS			GROSS Kg
										L/A	L/B	H	
MULTI INOX 3 M	380	170	215	175	184	170	220	1"	1"	460	230	270	8.8
MULTI INOX 4 M	430	170	215	175	209	170	220	1"	1"	460	230	270	11.3
MULTI INOX 5 M	455	170	215	175	234	170	220	1"	1"	460	230	270	12.5