

KPS / KPF

PERIPHERAL ELECTRIC PUMPS

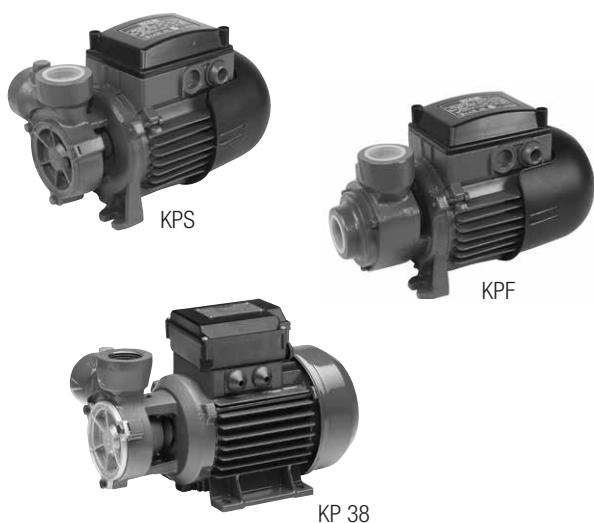

TECHNICAL DATA

Operating range:

from 5 to 50 l/m with head up to 84 metres.

Pumped liquid: clean, free of solids and abrasives, non-viscous, non-aggressive, non-crystallised and chemically neutral.

Liquid temperature range:

from 0 °C to +35 °C for domestic use.

from -10°C to +50°C for other uses.

Maximum ambient temperature: +40°C

Maximum operating pressure: 10 bar (6 bar for KPS-KPF 30/16).

Installation: fixed, horizontal position.

Motor protection class: IP 44

Protection class at the terminal board:

IP 55 for KP38/18 and for KPF 45/20;

IP44 for KPF/S 30/16

Insulation class: F

Standard voltage: single-phase 1 x 230 V / 50 Hz

three-phase: 3 x 230-400 V / 50 Hz.

Special executions on requests: alternative voltages and frequencies.

APPLICATIONS

Peripheral centrifugal pump with compact dimensions. Capable of generating high heads and suitable for domestic installations, water supply systems, small gardening applications, draining and filling cisterns, and for light industrial uses, such as feeding pressurized boilers (anti-condensation).

CONSTRUCTION FEATURES OF THE PUMP

Brass pump body and motor support for KP 60/6 and KP 60/12. Pump body with radial suction for KP and KPS; front suction for KPF. Cast iron support with brass wear disc for KPS 30/16 and KP 38/18. KPS 30/16 is available on request with bronze pump body and support. Brass impeller. Carbon/ceramic mechanical seal.

CONSTRUCTION FEATURES OF THE MOTOR

Closed asynchronous type, external ventilation cooling. Rotor running on permanently lubricated ball bearings, oversized to ensure low noise and durability. Standard built-in thermo-amperometric protection. Capacitor permanently fitted on single phase versions. For the protection of the three-phase motor, we recommend the use of remote overload cut-outs, in compliance with current local regulations. Construction according to CEI 2-3 and CEI 61-69 (EN 60335-2-41).

MATERIALS

No.	PARTS* KPS	MATERIALS
1	PUMP BODY	CAST IRON 200 UNI ISO 185
4	IMPELLER	BRASS PCU ZN 40 PB2 UNI 5705/65
7	SHAFT WITH ROTOR	AISI 416 STAINLESS STEEL X12 CRS 13 UNI 6900/71
16	MECHANICAL SEAL	CARBON / CERAMIC
28	OR RING	NBR
33	COVER	BRASS PCU ZN 40 PB2 UNI 5705/65

No.	PARTS* KPF	MATERIALS
1	PUMP BODY	G20 EN-GJL-250 UNI EN 1561
3	MOT. SUPP. PUMP	G20 EN-GJL-250 UNI EN 1561
4	IMPELLER	BRASS PCU ZN 40 PB2 UNI 5705/65
7	SHAFT WITH ROTOR	AISI 416 STAINLESS STEEL X12 CRS 13 UNI 6900/71
16	MECHANICAL SEAL	CARBON / CERAMIC
28	OR RING	NBR

No.	PARTS* KP 38	MATERIALS
1	PUMP BODY	CAST IRON 200 UNI ISO 185
4	IMPELLER	BRASS PCU ZN 40 PB2 UNI 5705/65
7	SHAFT WITH ROTOR	AISI 416 STAINLESS STEEL X12 CRS 13 UNI 6900/71
16	MECHANICAL SEAL	CARBON / CERAMIC
28	OR RING	NBR
33	COVER	BRASS PCu Zn 40 Pb2 UNI 5705/65

* In contact with the liquid

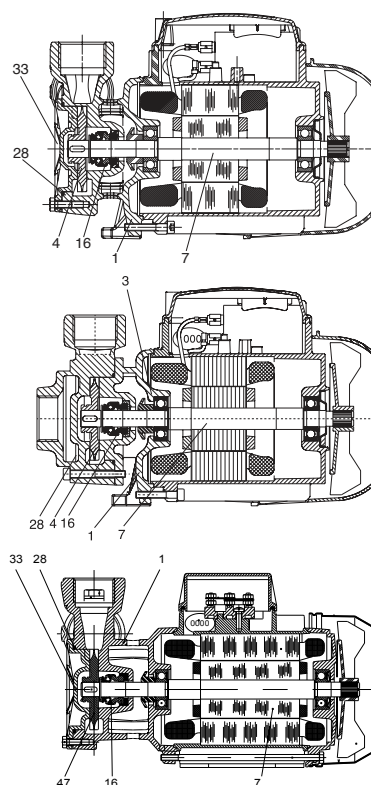

KPA - KPS / KPF - KP RANGE

PERIPHERAL ELECTRIC PUMPS

PERFORMANCE RANGE

The performance curves are based on kinematic viscosity values = 1 mm²/s and density equal to 1000 kg/m³. Curve tolerance according to ISO 9906.

GRAPHIC SELECTION TABLE

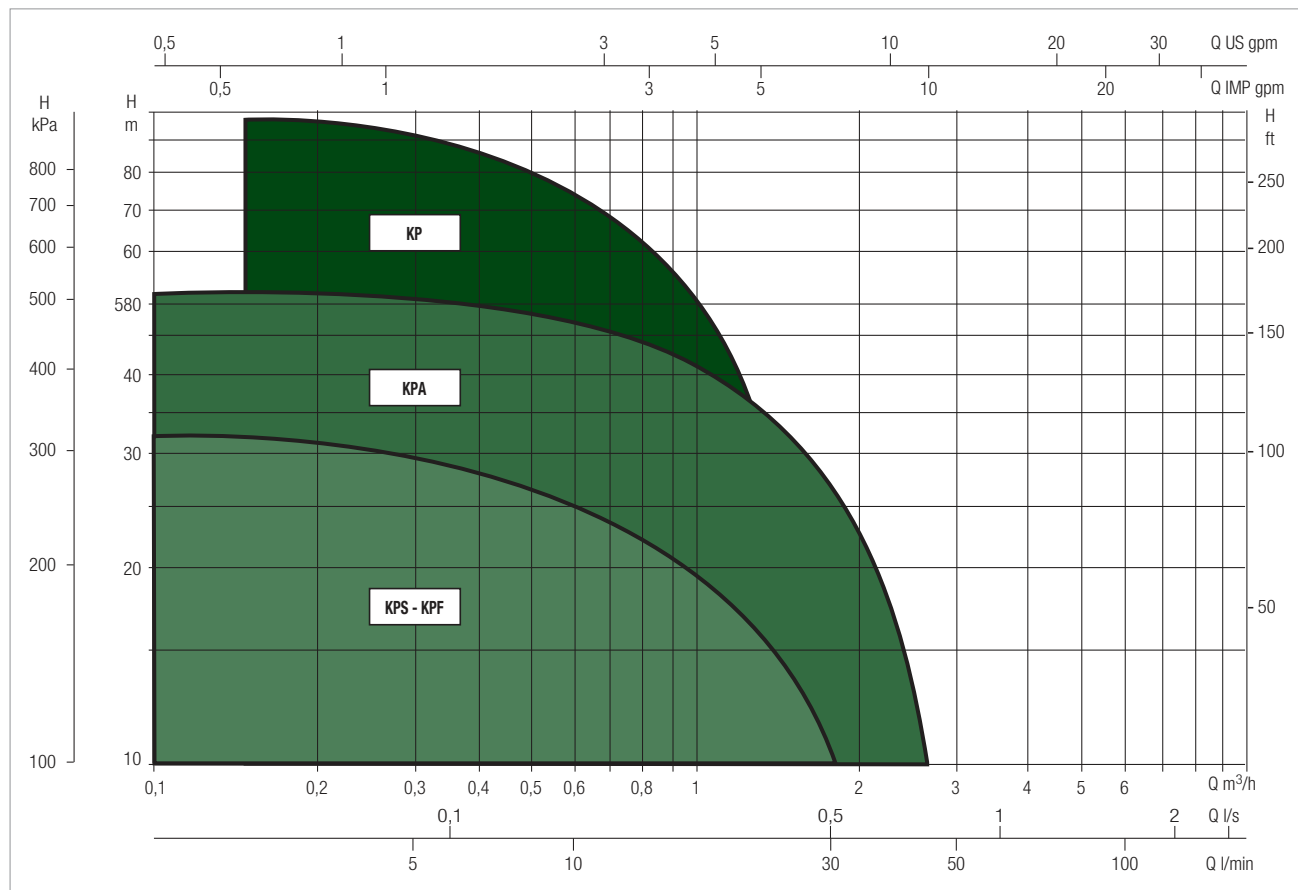

SELECTION TABLE

MODEL	Q=	0	0.3	0.6	0.9	1.2	1.8	2.4	
	Q=	0	5	10	15	20	30	40	
	m ³ /h	l/min	H (m)						
KPF 30/16 M			32.5	31	25	22	17.5	10	
KPF 30/16 T			32.5	31	25	22	17.5	10	
KPS 30/16 M			32.5	31	25	22	17.5	10	
KPS 30/16 T			32.5	31	25	22	17.5	10	
KP 38/18 M			54	50	46	41	36	27.5	17.5
KP 38/18 T			54	50	46	41	36	27.5	17.5
KPF 45/20 M			84	76	68	62	56	38	24
KPF 45/20 T			84	76	68	62	56	38	24

KPS - PERIPHERAL ELECTRIC PUMPS FOR THE SUPPLY OF WATER IN DOMESTIC ENVIRONMENTS

Pumped liquid temperature range: from 0 °C to +35 °C for domestic use. From -10 °C to +50°C for other uses.

Maximum ambient temperature: +40°C

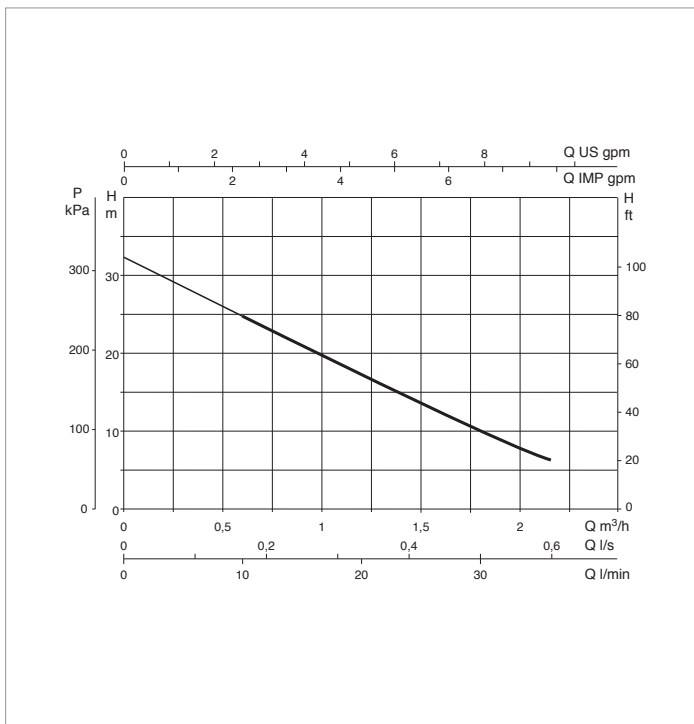
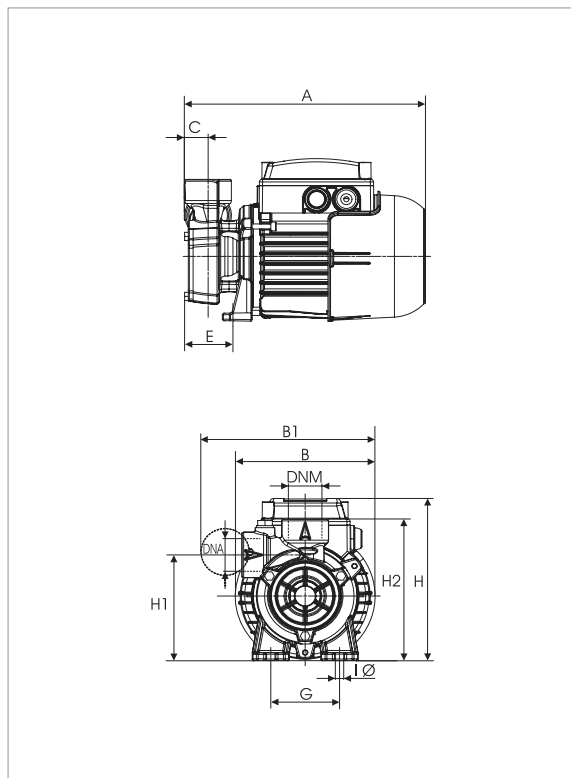

The performance curves are based on kinematic viscosity values = 1 mm²/s and density equal to 1000 kg/m³. Curve tolerance according to ISO 9906.

MODEL	ELECTRICAL DATA						
	POWER INPUT 50 Hz	P1 MAX kW	P2 NOMINAL		In A	CAPACITOR	
			kW	HP		μF	Vc
KPS 30/16 M	1 x 230V ~	0.47	0.37	0.5	2	8	450
KPS 30/16 T	3 x 230 - 400V ~	0.47	0.37	0.5	1,4 - 0.8	-	-
KPS 30/16 M-P ¹	1 x 230V ~	0.47	0.37	0.5	2	8	450

MODEL	A	B	B1	C	E	F	G	I Ø	H	H1	H2	DNA	DNM	PACKING DIMENSIONS			VOLUME (m ³)	WEIGHT kg
														L/A	L/B	H		
KPS 30/16	228	132	165	22	46	-	65	8	158	103	138	1" G	1" G	259	164	197	0.008	5.4

KPF - PERIPHERAL ELECTRIC PUMPS FOR THE SUPPLY OF WATER IN DOMESTIC ENVIRONMENTS

Pumped liquid temperature range: from 0 °C to +35 °C for domestic use. From -10 °C to +50°C for other uses.

Maximum ambient temperature: +40°C

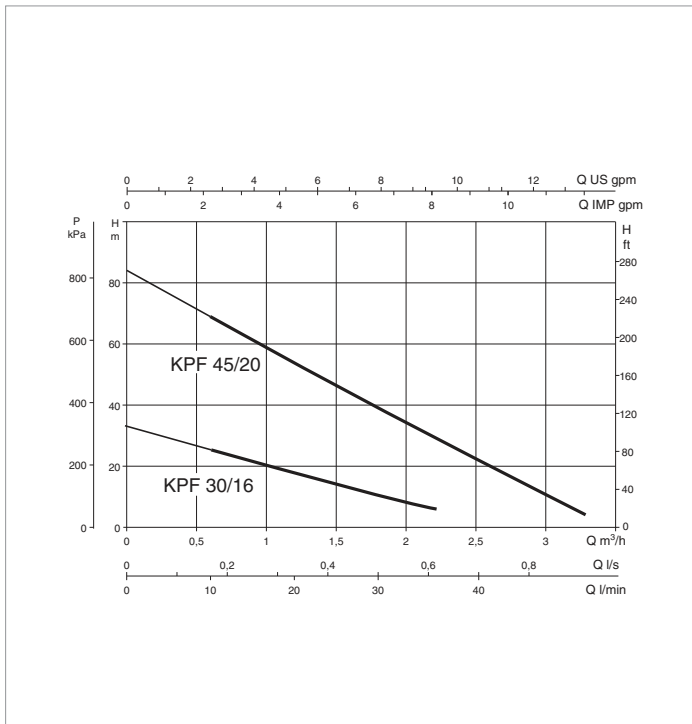
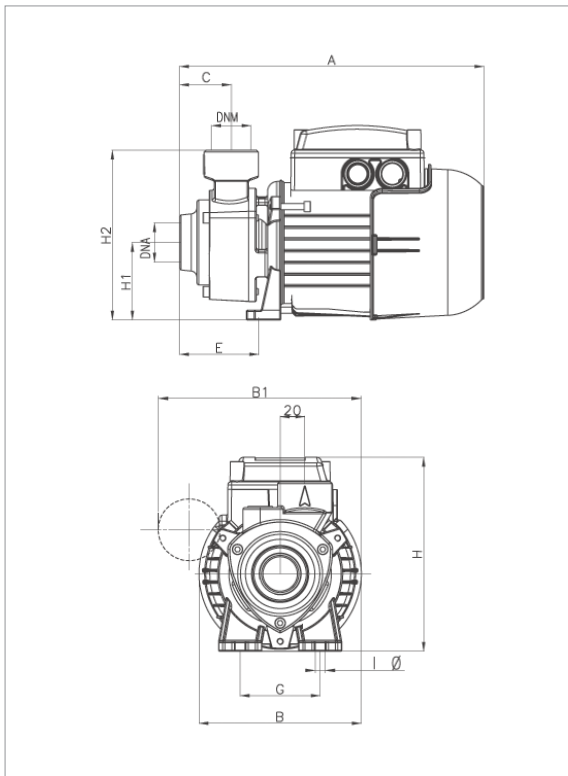

The performance curves are based on kinematic viscosity values = 1 mm²/s and density equal to 1000 kg/m³. Curve tolerance according to ISO 9906.

MODEL	ELECTRICAL DATA						
	POWER INPUT 50 Hz	P1 MAX kW	P2 NOMINAL		In A	CAPACITOR	
			kW	HP		µF	Vc
KPF 30/16 M	1 x 230V ~	0.53	0.37	0.5	2.37	8	450
KPF 30/16 T	3 x 230 - 400V ~	0.47	0.37	0.5	1,45 - 0.82	-	-
KPF 45/20 M	1 x 230V ~	1.5	1	1.34	5.9	25	450
KPF 45/20 T	3 x 230 - 400V ~	1.4	1	1.34	-	-	-

MODEL	A	B	B1	C	E	F	G	I Ø	H	H1	H2	DNA	DNM	PACKING DIMENSIONS			VOLUME (m ³)	WEIGHT kg
														L/A	L/B	H		
KPF 30/16	247	132	165	42	64	-	65	8	158	63	138	1" G	1" G	262	140	180	0.0083	5.3
KPF 45/20	315	155	-	55	95	-	112	7	188	78	163	1" G	1" G	325	165	198	0.014	12

KP 38/18 - PERIPHERAL ELECTRIC PUMPS FOR THE SUPPLY OF WATER IN DOMESTIC ENVIRONMENTS

Pumped liquid temperature range: from 0 °C to +35 °C for domestic use. From -10 °C to +50°C for other uses.

Maximum ambient temperature: +40°C

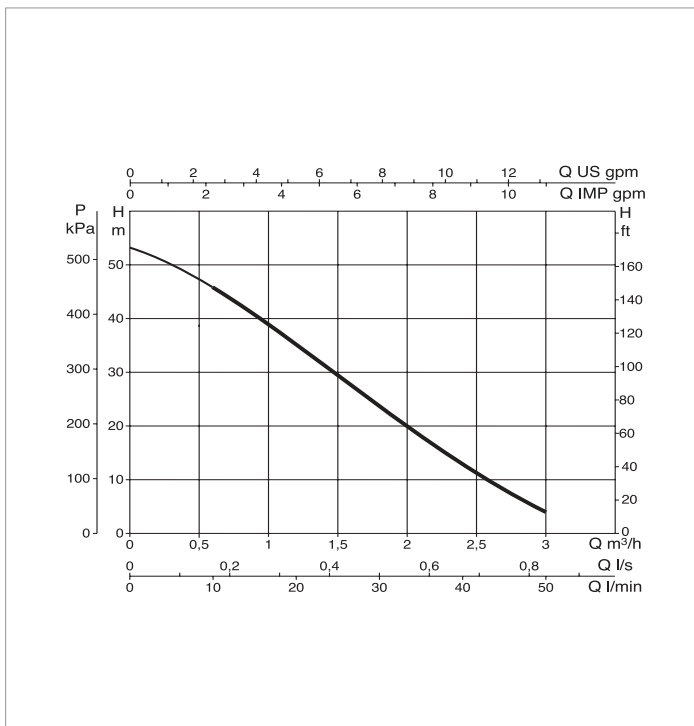
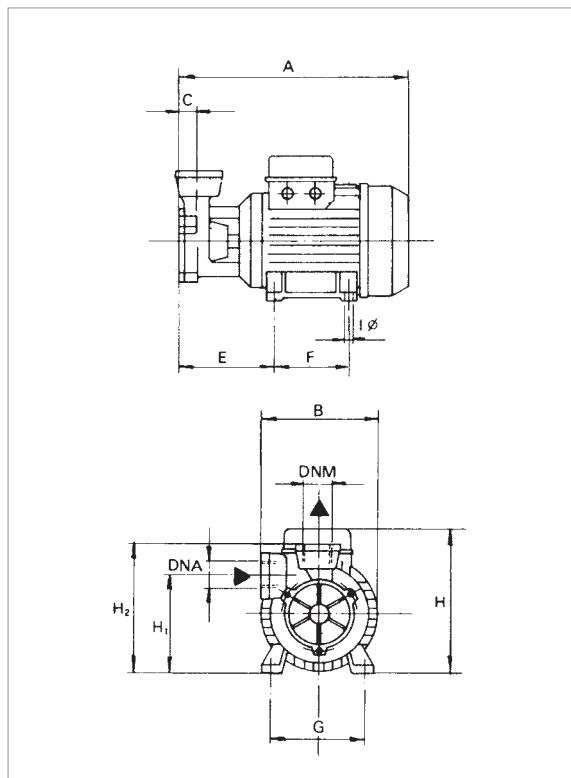

The performance curves are based on kinematic viscosity values = 1 mm²/s and density equal to 1000 kg/m³. Curve tolerance according to ISO 9906.

MODEL	ELECTRICAL DATA						
	POWER INPUT 50 Hz	P1 MAX kW	P2 NOMINAL		In A	CAPACITOR	
			kW	HP		µF	Vc
KP 38/18 M	1 x 230V ~	0.89	0.6	0.8	4	12.5	450
KP 38/18 T	3 x 230 - 400V ~	0.86	0.6	0.8	2.9 - 1.7	-	-

MODEL	A	B	B1	C	E	F	G	I Ø	H	H1	H2	DNA	DNM	PACKING DIMENSIONS			VOLUME (m ³)	WEIGHT kg
														L/A	L/B	H		
KP 38/18	255	130	-	26	106	80	100	7	186	108	153	1" G	1" G	271	176	209	0.01	7.5