



UNI EN 12845 FIRE-FIGHTING SETS



DABPUMPS.COM

DAB[®]
WATER • TECHNOLOGY



Max 2000 Kg.

DO NOT WORK UNDER THE TABLE
IF NOT MECHANICALLY BLOCKED.
NEI LAVORARE SOTTO LA TAVOLA
SE NON E' MECCANICAMENTE BLOCCATA.



8/5

DAB AND FIRE-FIGHTING



With **over 2 million items produced every year**, DAB electric pumps are synonym of technology and reliability. Established in 1975, DAB PUMPS is today **an international point of reference in the water movement sector**.

The careful selection of materials and the approval procedures applied to each line before production release, ensure both product **resistance and maximum performance levels**.

During the last years DAB has invested resources, passion and energy, acquiring companies with different specific skills, from electronics to motors.

All this has allowed us to present ourselves as a solid partner capable of offering **solutions designed and created entirely in Italy** that can meet the needs of modern technical engineering.

WHY CHOOSE DAB FIRE-FIGHTING SETS



DAB fire-fighting sets were developed to ensure reliability, efficiency and easy maintenance, translating design choices into significant advantages for designers, and installation and maintenance personnel.

1KDN COMPACT

UNI EN 12845 FIRE-FIGHTING SETS WITH STANDARDISED CENTRIFUGAL PUMPS



Diesel and electric motor fire-fighting sets, ideal for automatic sprinkler systems and/or hydrants of commercial buildings. Designed to be coupled with each other, in order to obtain all the versions and meet all the requirements of the EN 12845 and UNI 10779 standards.

By means of an elastic spacer coupling, the pump is coupled to an electric (efficiency level IE3) or Diesel motor capable of providing the power absorbed by the pump at any pump load condition, from no-load, to a load corresponding to NPSH16m (as requested by section 10.1 of the UNI EN 12845 standard).

• Modular design:

The UNI EN 12845 DAB fire-fighting sets are supplied in modular version. This setup facilitates transport, and the installation of DAB fire-fighting pump sets in pump rooms, even with narrow access doors.

Thanks to a coupling kit (supplied as accessory), it is possible to obtain all the compositions contemplated by the standard (one, two, or three electric or Diesel pumps, with or without jockey pump).

EXAMPLES OF INSTALLATION WITH 1KDN



FLOODED SUCTION INSTALLATION

The standards set down, in order of preference, the various ways in which a pump for a fire-fighting set can be installed.

End-suction horizontal pumps must be installed with flooded suction whenever possible, and the standard EN12845 clearly defines the parameters for flooded suction installation:

- at least two thirds of the actual suction tank capacity must be above the level of the axis of the pump;
- the axial line of the pump must not be more than 2 m above the minimum level of water in the supply tank.

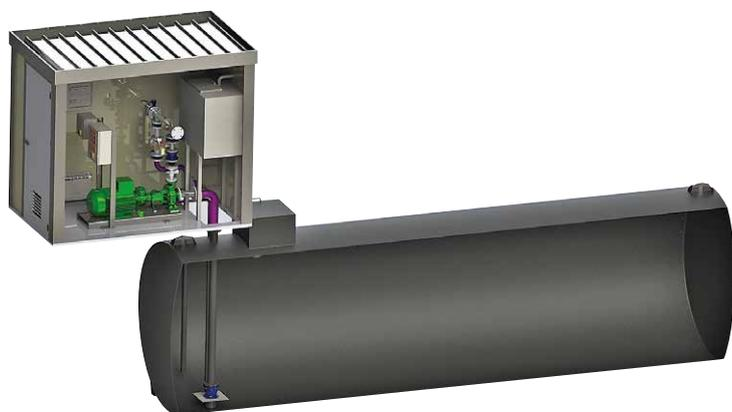

SUCTION LIFT INSTALLATION

Suction lift installation is the alternative when flooded suction installation is not possible. Standard EN12845, however, advises against suction lift installation and specifies that it should be considered only when flooded suction installation is not feasible.

The standard indicates a maximum distance of 3.2 m between the axial line of the pumps and the lowest point of the suction piping. Specific priming pumps must also be installed above the main pumps (1 per main pump) to ensure that these are all primed.

1KDN COMPACT FEATURES



COLLECTION RESERVOIR

Reservoir for the collection of any fuel leaking out of the diesel tank, included up to 11kW, pursuant to UNI 11292.



BATTERIES - MAINTENANCE

Batteries and sensitive components are in front of the fire-fighting set, making their maintenance simpler.



FRAME

Compact steel frame painted RAL 3000 red to support the pump, with anti-vibration devices to dampen the vibrations transmitted to the system.



TANK

All the engine-drive pumps have a fuel pump sized to ensure 6 hours of operation, as required for the highest hazard classes pursuant to standard EN12845 - 10.9.6.



ALARM REMOTE CONTROL UNIT

Alarm notification and remote control unit suitable for sets with 1 to 3 pumps. The GSM module accessory makes it possible to receive notification text messages in real time on the status of the pumping system.



CLAPET VALVE

An inspectionable check valve is mounted on the delivery port of each main pump to facilitate maintenance.



HIGH QUALITY

Fire-fighting sets designed and manufactured with components that guarantee a high standard of quality.



DESIGN

Compact sizes and modular structure, for coupling together (modular design) in order to meet the requirements of all the versions of the EN 12845 standard, as well as making transport and handling in restricted spaces easier.



HYDRAULICS

End-suction back pull out (as required by the EN 12845 - 10.1 standard) horizontal axis standardised centrifugal pump coupled with an electric or Diesel motor by means of an elastic spacer coupling protected by safety coupling cover.



MOTORS

The motors of all the main pumps are sized in accordance with standard EN 12845 - 10.1 to supply the power absorbed by the pump under any load conditions up to an NPSH value of 16 m.c.w.



CONTROL PANELS

All the fire-fighting sets have an electric control panel pursuant to EN 12845 / UNI 10779 for each main pump and an electric control panel for the jockey pump, already connected to the main components (motor, pressure switches, sensor, batteries, etc.).

EXTENSIVE RANGE

DAB can offer the widest range of fire-fighting sets available on the market.
With flow rates up to 650 m³/h and heads up to 130 m.

PERFORMANCE OF THE 1KDN

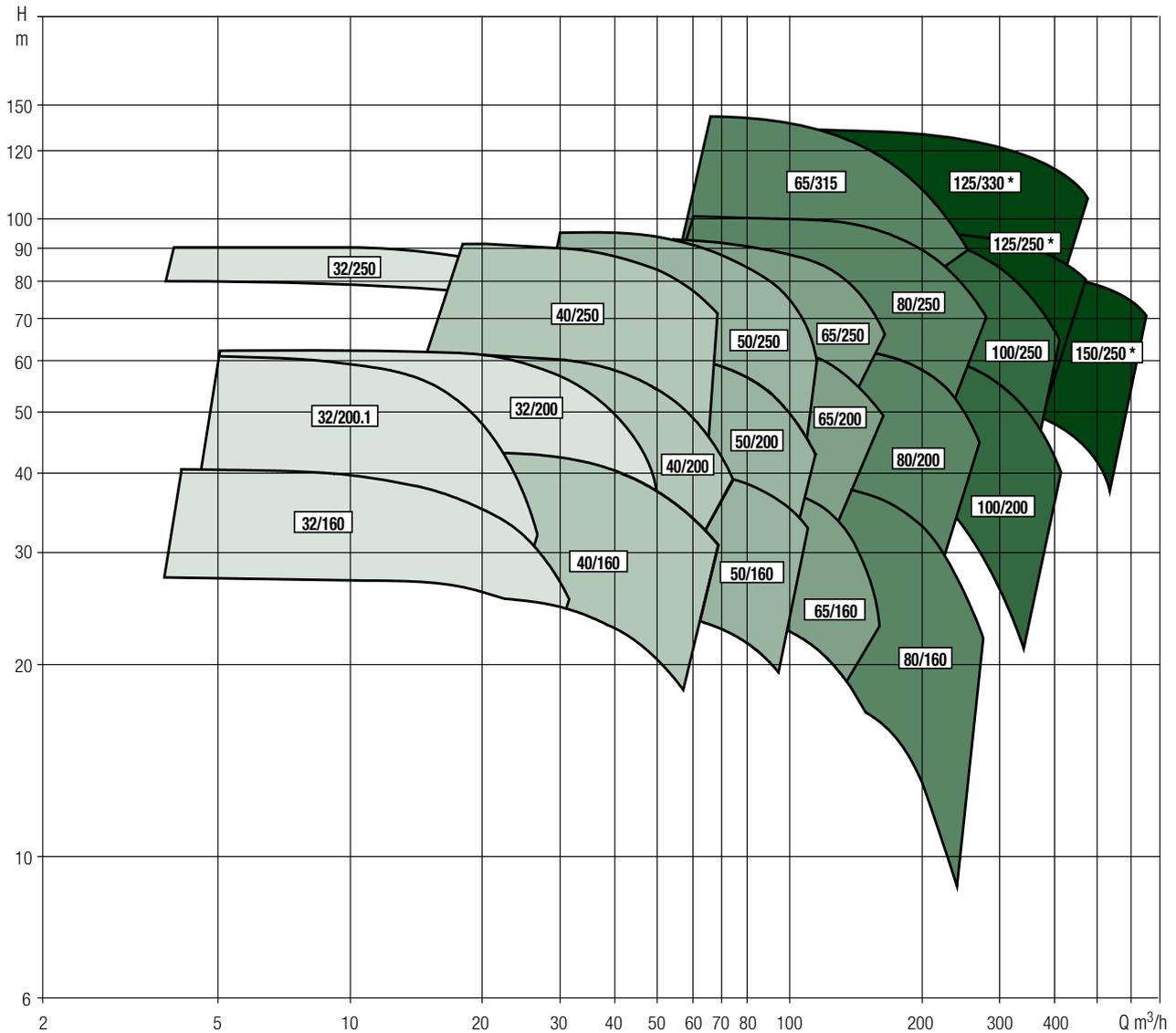

* Oversize versions of the KDN: 125-250 / 125-330 / 150-250

OVERSIZE KDN RANGE

- FLOW: UP TO 650 m³/h
- HEAD: UP TO 130 m.

RANGE OF STANDARD VERSIONS OF THE KDN

- FLOW: UP TO 400 m³/h
- HEAD: UP TO 120 m.



1KVT

UNI EN 12845 FIRE-FIGHTING SETS WITH VERTICAL TURBINE PUMPS

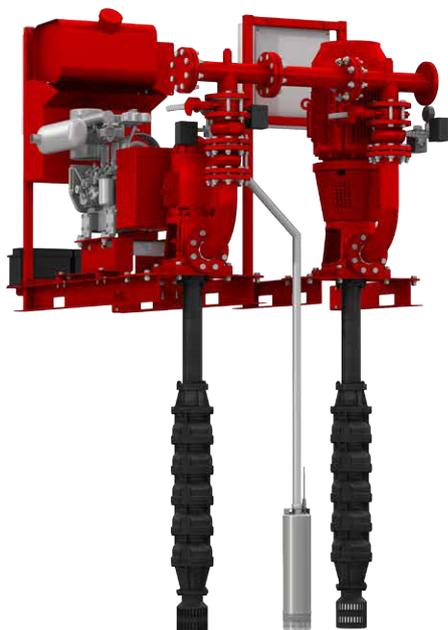

The new 1KVT fire-fighting pump sets with diesel engine or electric motor assembly, ideal for automatic sprinkler systems and/or hydrants of commercial buildings, are manufactured using vertical turbine pumps, in accordance with article 10.6.1 of UNI EN 12845 standards.

- **Simple maintenance:**

Thanks to the submersible pump body and the motor assembly control above the surface, they eliminate any self-priming issues, in addition to making the job of the maintenance technician much easier.

- **Modular design:**

DAB pressurisation sets are designed to be coupled with each other, in order to obtain all the versions and meet all the requirements of the UNI EN 12845 standard.

Available set models:

- **1 KVT EN**

consisting of an axial flow submersible pump (vertical turbine pump) with electric motor, including submersible pump, cork plug, control head installed on appropriate base, electric control panel.

- **1 KVT MD EN**

consisting of an axial flow submersible pump (vertical turbine pump) with air or radiator cooled diesel engine (heat exchanger on request), including submersible pump, cork plug, control head installed on appropriate base, electric control panel, diesel tank ensuring 6 hours of operation, with fuel collection tank for powers up to 26 kW.

EXAMPLES OF INSTALLATION WITH 1KVT

FLOODED SUCTION INSTALLATION

Standard EN12845 recommends the use of vertical turbine pumps when flooded suction installation with end-suction horizontal pumps is not possible. Vertical turbine pumps offer the great advantage, in fact, of flooded suction installation even with an underground tank.

Thanks to the submersible pump body and the motor assembly control above the surface, they eliminate any self-priming issues, in addition to making the job of the maintenance technician much easier.

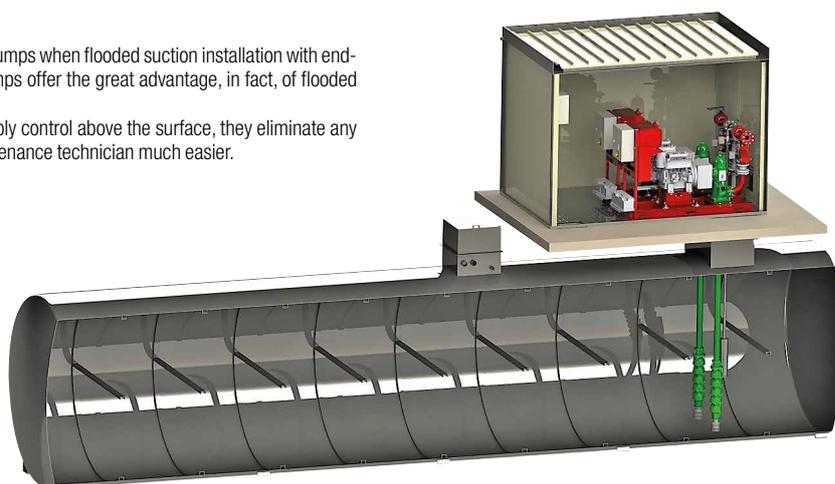

1KVT FEATURES



VERTICAL TURBINE PUMP

Vertical turbine pumps offer the great advantage of flooded suction installation even with an underground tank (UNI EN 12845 – 10.6.1). Vertical turbine pumps have a cataphoresis paint coating and cork plug, and can be coupled with an electric motor or diesel engine through a control head installed on an appropriate base.



ANTI-VORTEX PLATE

Vertical turbine pumps can be equipped with anti-vortex plates to decrease the speed on the suction side (UNI EN 12845 – 9.3.5), in order to make the most of the volume of the storage tank.



CONTROL HEAD

Control head connected to the motor with 3-part spacer coupling. This means the 2 components (motor or pump) can be removed separately in accordance with UNI EN 12845 – 10.1.



TANK

Each diesel engine driven pump has a diesel tank that guarantees 6 hours of operation. For engine powers up to 26 kW, a collection tank is also included (in compliance with UNI 11292), for the containment of any fuel spillages.



COUPLING KIT

In order to obtain all the versions contemplated by the standard (2-3 pump sets), DAB supplies as accessory a coupling kit, to be fitted between the delivery manifolds of the individual sets.

DIESEL MODULE

ELECTRIC MODULE

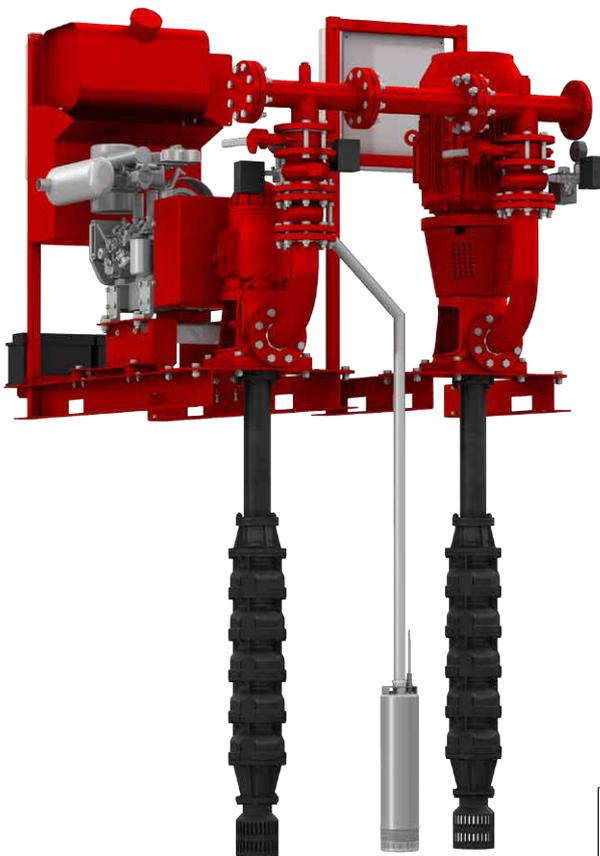

AXIAL LINE

The axial line is a flanged pipe treated with black cataphoresis paint coating and equipped with a transmission shaft that connects the submersible pump to the control head, with the corresponding guide supports. (separate accessory)



JOCKEY PUMP

Submersible jockey pump with 20-litre expansion vessel and its own electric control panel.



FLOW METER

The measuring kit with flow meter must be installed on a branch on the delivery manifold of the set. It is used to check the performance of the main pumps.

EXTENSIVE RANGE

DAB can offer the widest range of fire-fighting sets available on the market.
With flow rates up to 300 m³/h and heads up to 150 m.

PERFORMANCE OF THE 1KVT

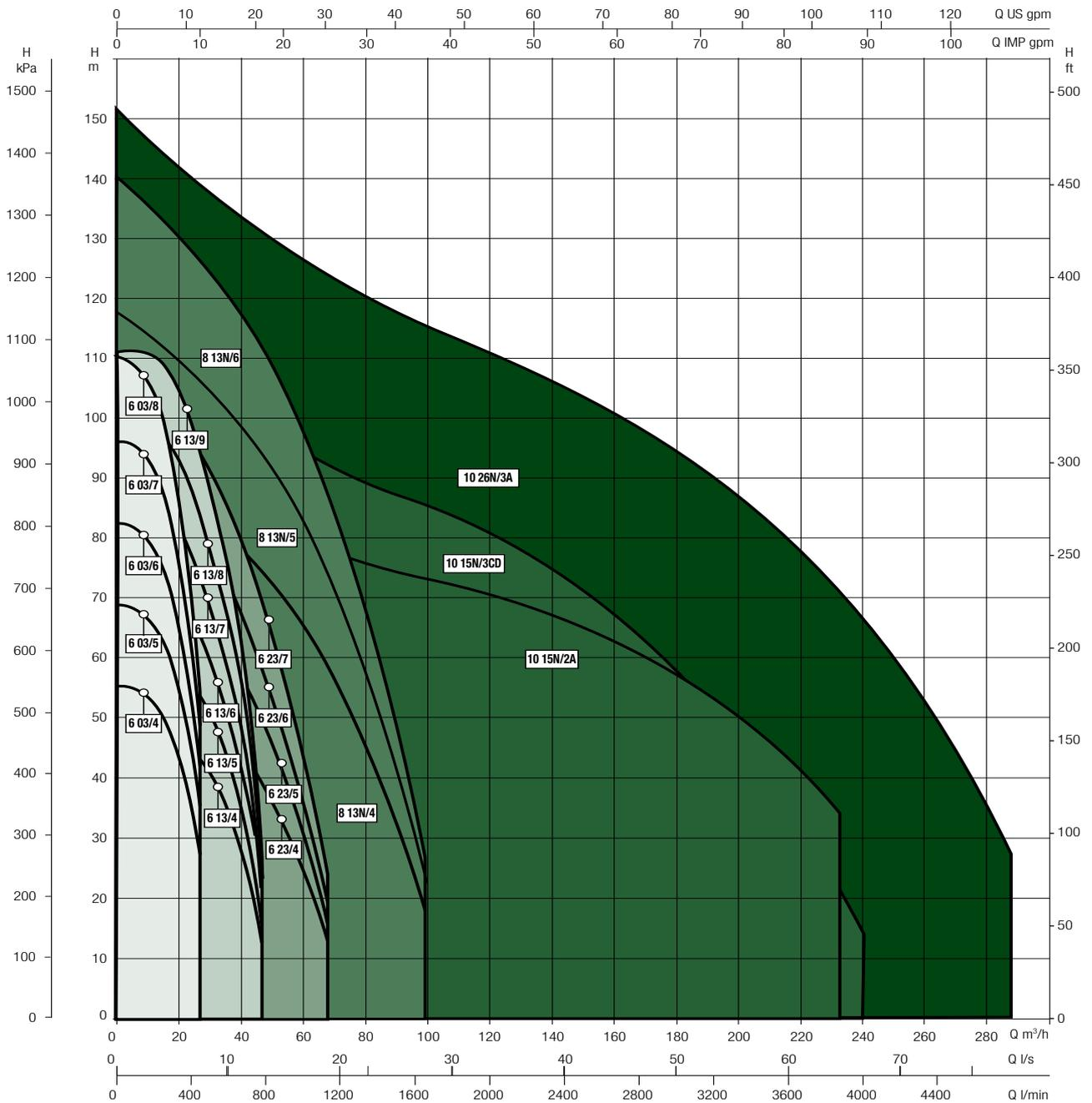

1KVT RANGE

- FLOW: UP TO 300 m³/h
- HEAD: UP TO 150 m.



Max 2000 Kg

DO NOT WORK UNDER THE TABLE
IF NOT MECHANICALLY BLOCKED
NON METTERSI SOTTO QUESTA PIATTAFORMA
SE NON È BLOCCATA MECCANICAMENTE

RINO TULLIO
PRESSE DINAMICHE
PIATTAFORME DI SOLLEVAMENTO



RELIABILITY

By selecting DAB Pumps as your partner, you will have the confidence of obtaining fire-fighting systems that meet the highest quality standards. **Our sets meet the requirements of the UNI EN 12845 standard and are capable of ensuring high reliability and safety.**

As a further guarantee, in 2014 we asked an External Certifying Body, **Istituto Giordano**, renowned for its knowledge of the fire-fighting sector, to carry out a "technical assessment of conformity to the specifications of the UNI EN 12845 standard", which enables us to obtain the Certification, and the certainty of offering to our customers products of the highest quality.

DAB is also committed to supporting the customer with a complete offer of assistance, both before and after the sale.



UNI EN 12845



UNI 10779

TESTING

We test all the fire-fighting sets directly at our premises.

Highly specialised professionals test each and every component to make sure that it meets the quality standards that have always set the DAB solutions apart.



MODULAR DESIGN

DAB fire-fighting sets are fully customisable.

We believe that this approach is decisive in setting us apart from the competition, allowing us to offer "tailor-made" solutions.

Each and every type of installation can be directly evaluated with the designer, developing together the best solutions for meeting all the needs of the customer.



TRANSPORT AND INSTALLATION

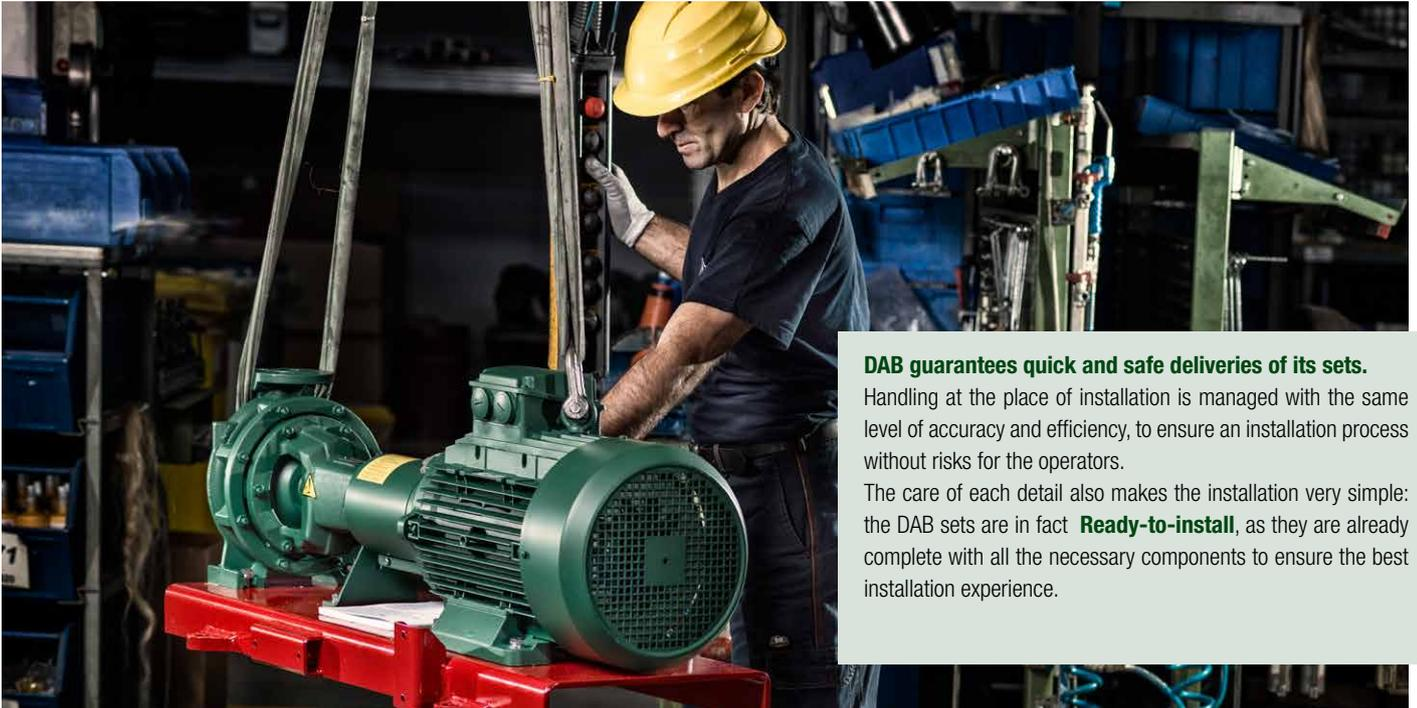

DAB guarantees quick and safe deliveries of its sets.

Handling at the place of installation is managed with the same level of accuracy and efficiency, to ensure an installation process without risks for the operators.

The care of each detail also makes the installation very simple: the DAB sets are in fact **Ready-to-install**, as they are already complete with all the necessary components to ensure the best installation experience.

SPARE PARTS

DAB holds a full spare parts warehouse, capable of promptly meeting the requests of its customers.

Thanks to full availability of spare parts and accessories, assistance and replacement requests are handled with the utmost efficiency.



TECHNICAL SUPPORT CENTRES

Not just the product: attention to service and the overall experience of the customer are just as important. This is why DAB always follows the customer through all the stages.

From design to installation, to highly specialised training and maintenance activities, our skilled staff makes available its know-how and experience, to ensure constant communication and exchange with its partners.

This is why we have organised across the whole national territory a **capillary network of Technical Support Centres**, and why our Service department always provides technical and information support.

REFERENCES



1 KDN

MILAN (ITALY)

PUMPING SYSTEMS FOR THE OBI – BURGER KING BUSINESS PARK

THE REQUEST: The new "business park" covers about 7,000 square metres in the province of Milan and consists of an OBI store and a Burger King restaurant. DAB supplied pumping sets, including:

- 450 m³/h sprinkler fire-fighting system with a set consisting of two diesel pumps and one electric pump.



1 KDN

OSTIA (ITALY)

FIRE-FIGHTING SET FOR GRASSI HOSPITAL IN OSTIA

THE APPLICATION: Following the renovation of Ostia Hospital, the fire-fighting set was replaced with a DAB set consisting of an electric pump, a jockey pump and a diesel engine-driven pump, specifically:

- Diesel engine-driven pump 60150083 1KDN 100-330/290 MD EN 12845
- Electric pump 60177080 1KDN 100-330/290 110 T400/50 IE3 EN 12845-KV 3/15

Both these pumps meet the following requirements:

- flow rate = 230 m³/h / head = 140 metres / motor power = 110 kWatt.



1 KDN

TERNI (ITALY)

ADAPTATION OF THE CENTRAL WAREHOUSE FIRE-FIGHTING SYSTEM TO THE EN 12845 STANDARD

THE REQUEST: the upgrade of the general warehouse fire-fighting system was completed using a water pressurization fire-fighting system designed and built in full compliance with European standard EN 12845. The fire-fighting sets include standardised centrifugal electric and diesel pumps. Integrated with the ceilings of the buildings:

2 pumps with the following characteristics were installed: Q = 180 m³/h and H = 6 bar P = 103 kW, suitable for industrial plants. The project was completed in collaboration with NG.EN.I.A. Gruppo Professionisti Associati.



1 KDN

KATOWICE (POLAND)

FIRE-FIGHTING AND PRESSURIZATION SET FOR THE MPGK COMPANY IN KATOWICE, POLAND

THE APPLICATION: MPGK (Municipal Public Utilities Ltd) is a company that provides biological waste treatment and management services; its goal is to improve the quality of life of residents by investing in projects related to the protection of the environment.

This company has further demonstrated its commitment to the use of innovative, environmentally friendly products to protect stocks of raw materials by installing, at its plant, a 37 kW (1KDN 80-200/200) DAB electric fire-fighting set with a vertical multistage three-phase centrifugal jockey pump (KVCX) that ensures the utmost reliability of the system even in the case of small leaks in the system.



1 KDN

BRATISLAVA (SLOVAKIA)

FIRE-FIGHTING SET FOR THE FLEXI HALA INDUSTRIAL COMPLEX IN BRATISLAVA, SLOVAKIA

THE APPLICATION: Inside the industrial complex, and within the LOGIS Invest area, is a building with characteristics for adaptation to the light industrial and logistic sectors, designed with a flexible structure, to enable exploitation by many users.

For this building, we were asked to install a compact 1KDN fire-fighting set.

The KDN 65 / 200- 190 centrifugal pump with a power of 11 kW has a new generation IE3 electric motor that provides better energy efficiency. The pump also has a standard joint for coupling with electric motors or diesel engines, depending on the design specifications.

REFERENCES



COTE D'IVOIRE (AFRICA)

A FIRE-FIGHTING SET FOR THE NEW PREMISES OF ABIDJAN BANQUE IN COTE D'IVOIRE

THE APPLICATION: BDA is a subsidiary of Société Ivoirienne des Finances (SIF), created by the Post Office of Cote d'Ivoire and the BDK Group. BDA currently provides services for businesses, large companies and high end customers. A fire-fighting set, consisting of a KDN diesel pump, a KDN electric supply pump and a jockey pump, was installed at the new premises of DBA.



FERRARA (ITALY)

TWO FIRE-FIGHTING SETS FOR BRICOMAN IN FERRARA, ITALY

THE APPLICATION: Bricoman opened its first store in France in 1999 and can now be found in 4 countries (France, Spain, Italy and Poland) with more than 70 outlets.

The group specialises in the wholesale and retail trade of professional technical products for the construction and renovation of houses and buildings. It commissioned DAB to install two 1KDN fire-fighting sets with an electric pump and a motor pump for its premises in Ferrara. The two 1KDN 100-250/240 EN 12845 90 kW centrifugal pumps can provide a maximum flow rate of 285 cubic metres/h with a head up to 35 metres.



PARMA (ITALY)

TWO 1KVT SETS FOR THE MERCEDES BENZ DEALERSHIP IN PARMA (ITALY)

THE APPLICATION: The new Mercedes dealership has a large showroom, a workshop for the inspection, testing and repair of vehicles, and a large outbuilding with part of the dealership where cars ready for delivery or ones already registered are kept. This area needed to be equipped with a standard fire-fighting system. Two KVT systems with axial flow vertical submersible pump, ideal for sprinkler and/or hydrant systems for commercial buildings, were chosen accordingly. These two pumps (one with electric motor and the other with diesel engine, both sized to meet 100% of the energy needs) are designed to be coupled together entirely to standard.



VENETO (ITALY)

TWO 1KVT FIRE-FIGHTING SETS FOR SME THE COMMERCIAL CENTRE OF SAN DONÀ DI PIAVE (VE)

THE APPLICATION: Gruppo SME specialises in sales in three main sectors: household appliances, bazaars and furniture. Following the expansion of the commercial centre in San Donà di Piave, DAB was commissioned to install two new 1KVT units with vertical turbine pumps in the place of the old fire-fighting system. The two units serve the entire commercial centre which, in addition to the SME centre, includes a supermarket, bars and shoe shops and other venues.

The system was installed in an outdoor room specially designed to hold a module with 8" vertical turbine pumps and a 37 kW electric motor, model 60184292 – 1KVT8 45N/4 37 400/50 EN12845, a module with 8" vertical turbine pumps and a 37 kW diesel engine with heat exchanger, model 60184309 – 1KVT8 45N/4 37 MD EN12845 S.C.



FRIULI VENEZIA GIULIA (ITALY)

NEW 1KVT FIRE-FIGHTING SET FOR CONSORZIO AGRARIO DEL FRIULI VENEZIA GIULIA

THE APPLICATION: For Consorzio Agrario, we installed a 1KVT EN 12845 fire-fighting set comprising an axial flow vertical submersible pump with 5.5 kW electric motor, including a submersible pump, cork plug, control head mounted on a suitable base, and an electric control panel. The choice of this set was the most suitable as, thanks to the submersible pump body and the motor assembly control above the surface, it eliminates any self-priming issues, in addition to making the job of the maintenance technician much easier.

**DAB PUMPS LTD.**

Unit 4 and 5, Stortford Hall Industrial Park,
Dunmow Road,
Bishops Stortford,
Herts
CM23 5GZ - UK
salesuk@dwtgroup.com
Tel. +44 1279 652 776
Fax +44 1279 657 727

**DAB PUMPS B.V.**

Brusselstraat 150
B-1702 Groot-Bijgaarden - Belgium
info.belgium@dwtgroup.com
Tel. +32 2 4668353
Fax +32 2 4669218

**DAB PUMPS B.V.**

Albert Einsteinweg, 4
5151 DL Drunen - Nederland
info.netherlands@dwtgroup.com
Tel. +31 416 387280
Fax +31 416 387299

**DAB PUMPEN DEUTSCHLAND GmbH**

Tackweg 11
D - 47918 Tönisvorst - Germany
info.germany@dwtgroup.com
Tel. +49 2151 82136-0
Fax +49 2151 82136-36

**DAB PUMPS IBERICA S.L.**

Calle Verano 18-20-22
28850 - Torrejón de Ardoz - Madrid
Spain
Info.spain@dwtgroup.com
Tel. +34 91 6569545
Fax: + 34 91 6569676

**DAB PUMPS HUNGARY KFT.**

H-8800
Nagykanizsa, Buda Ernő u.5
Hungary
Tel. +36 93501700

**DAB PUMPS POLAND Sp. z o.o.**

Mokotów Marynarska
ul. Postępu 15C
02-676 Warszawa - Poland
polska@dabpumps.com.pl
Tel. +48 223 816 085

**OOO DAB PUMPS**

Novgorodskaya str. 1, block G
office 308, 127247, Moscow - Russia
info.russia@dwtgroup.com
Tel. +7 495 122 0035
Fax +7 495 122 0036

**DAB PUMPS INC.**

3226 Benchmark Drive
Ladson, SC 29456 - USA
info.usa@dwtgroup.com
Tel. 1- 843-797-5002
Fax 1-843-797-3366

**DAB PUMPS SOUTH AFRICA PTY**

Twenty One industrial Estate,
16 Purlin Street, Warehouse 4, Unit B
Olifantsfontein - South - Africa
info.sa@dwtgroup.com
Tel. +27 12 361 3997
Fax +27 12 361 3137

**DAB PUMPS (QINGDAO) CO. LTD.**

No.40 Kaituo Road, Qingdao Economic & Technological
Development Zone
Qingdao City, Shandong Province - China
PC: 266500
sales.cn@dwtgroup.com
Tel. +86 400 186 8280
Fax +86 53286812210

**DAB PUMPS DE MÉXICO, S.A. DE C.V.**

Av Amsterdam 101 Local 4
Col. Hipódromo Condesa,
Del. Cuauhtémoc CP 06170
Ciudad de México
Tel. +52 55 6719 0493

**DAB PUMPS OCEANIA PTY LTD**

426 South Gippsland Hwy,
Dandenong South VIC 3175 - Australia
info.oceania@dwtgroup.com
Tel. +61 1300 373 677