

FEKA VS GRINDER

NEW RANGE

OUTSTANDING PERFORMANCE
FOR EVERY INSTALLATION



SUBMERSIBLE PUMPS
WITH SHREDDER FOR
SEWAGE



ACQUE CHIARE



ACQUE CARICHE



TRITURATORI



WATER • TECHNOLOGY

FEKA VS GRINDER

TOUGH AND EFFECTIVE FOR YOUR EVERY INSTALLATION NEED

Feka VS Grinder is a **single-stage submersible pump incorporating an AISI 630 stainless steel shredder**, designed for transferring untreated wastewater containing stringy material.

It is suited to settings where a high head is required, such as in the case of **pipework with a small diameter** or where **connection to the public sewer is some distance away**, or when wanting to avoid the **risk of clogging**. In addition, with its small footprint and both flanged and threaded outlet ports, Feka VS Grinder is ideal as a replacement in existing or outdated systems.

This is further testament to how DAB is attuned to the needs of all market players, from the installer to the end user: Feka VS Grinder is specifically sized to fully meet the functional, performance and consumption requirements of the specific applications for which it has been designed, ensuring maximum performance levels without wasting energy and economic resources.

Wear-resistant materials, such as cast iron and stainless steel, and performance capable of achieving heads of up to 25 metres, come together to ensure an **increasingly rewarding installation and user experience**, and a longer pump life.

UNBEATABLE SHREDDING EFFECTIVENESS

Feka VS Grinder features an **AISI 630 stainless steel shredder offering powerful shredding**. This ensures **safety and reliability** for all applications demanding a combination of impressive performance and low maintenance.

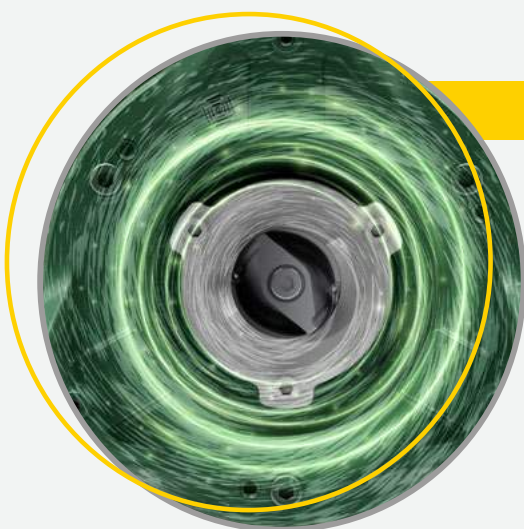

IT CAN GRIND, AMONG OTHER THINGS:

- RAGS OF VARIOUS SIZES AND DIFFERENT TYPES OF FABRIC
- VARIOUS TYPES OF GLOVES
- WIPES
- SANITARY TOWELS

It is certified according to **EN 12050-1**, the European standard that defines the design and construction specifications of systems for lifting waste water that may contain solid and faecal matter.

OVERVIEW

PLUG & PLAY

For reduced installation times and costs. With Feka VS Grinder, in the single-phase version with float, there is no need to connect the pump to an electrical panel, thus eliminating the time and money involved in bringing in an electrician: once installed, the pump is ready to go.

TRULY FLEXIBLE...

The DN32/DN40 flanged connection and the 40mm / 1½" threaded connection make Feka VS Grinder the perfect solution not just for new installations, but even for replacing obsolete pumps in existing systems or systems with small diameter pipework.

....AND TRULY VERSATILE

Powerful shredding, plug & play functionality, and connection flexibility make this product an ideal candidate for a wide range of installations.

APPLICATIONS AND INSTALLATIONS

Campsites or tourist facilities where, in addition to shredding power, a high head is also needed to reach particularly distant sewer connections.

HoReCa businesses where the use of oils and soaps tends to result in greater pump wear and tear.

Cellars and basements with pipework that has a small diameter or is prone to clogging.

Civil engineering applications with reservoirs that have to deal with various unscreened material.

Residential use for example, including rainwater collection tanks.

Processing with water that is non-acidic but contains stringy material of varying density, meaning high pressure is needed to transfer wastewater.



STAND ALONE

Can be put in any position as required

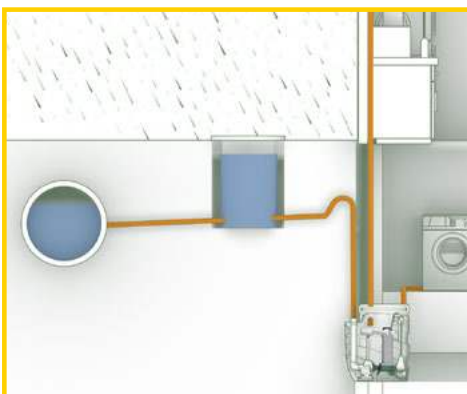

INSIDE THE BUILDING

Ideal for basement rooms like cellars and dens

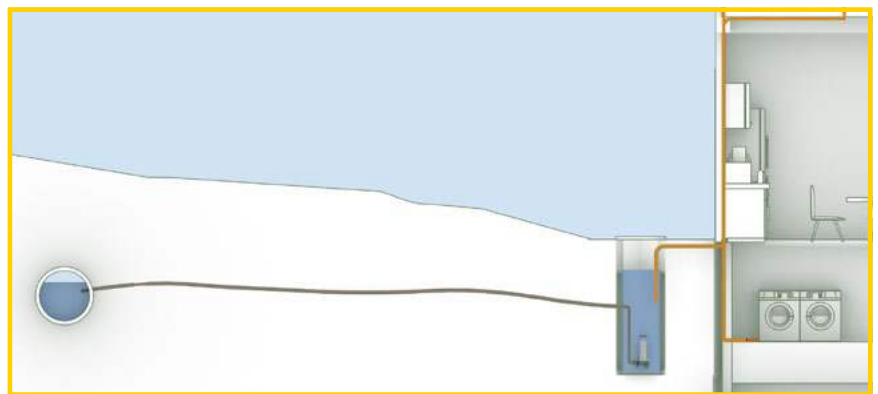

OUTSIDE THE BUILDING

When connection points are at a distance or on camp-sites and in small buildings

FEATURES

STRONG, POWERFUL AND VERSATILE

The **Feka VS Grinder**'s shredder offers a combination of professional performance and flexible use. Reliability and strength are assured by the distinctive design features shared across the **FEKA VS** family, further bolstered by the addition of up-spec'd components, such as the cast iron impeller and pump casing.

PLUG & PLAY

Thanks to the **float on the automatic single-phase version**, there is no need to connect Feka VS Grinder to an electrical panel so, once installed, the pump is ready to go.

PUMP BODY

The pump body is in **cast iron with cataphoresis treatment** for **greater protection against rust**.

OUTLET CONNECTIONS

With the **DN32/DN40 flanged connection and 40mm / 1½" threaded connection**, flexibility is assured for installation in either new or obsolete systems.

GRINDING SYSTEM

The grinding system is made of **AISI 630 stainless steel**.

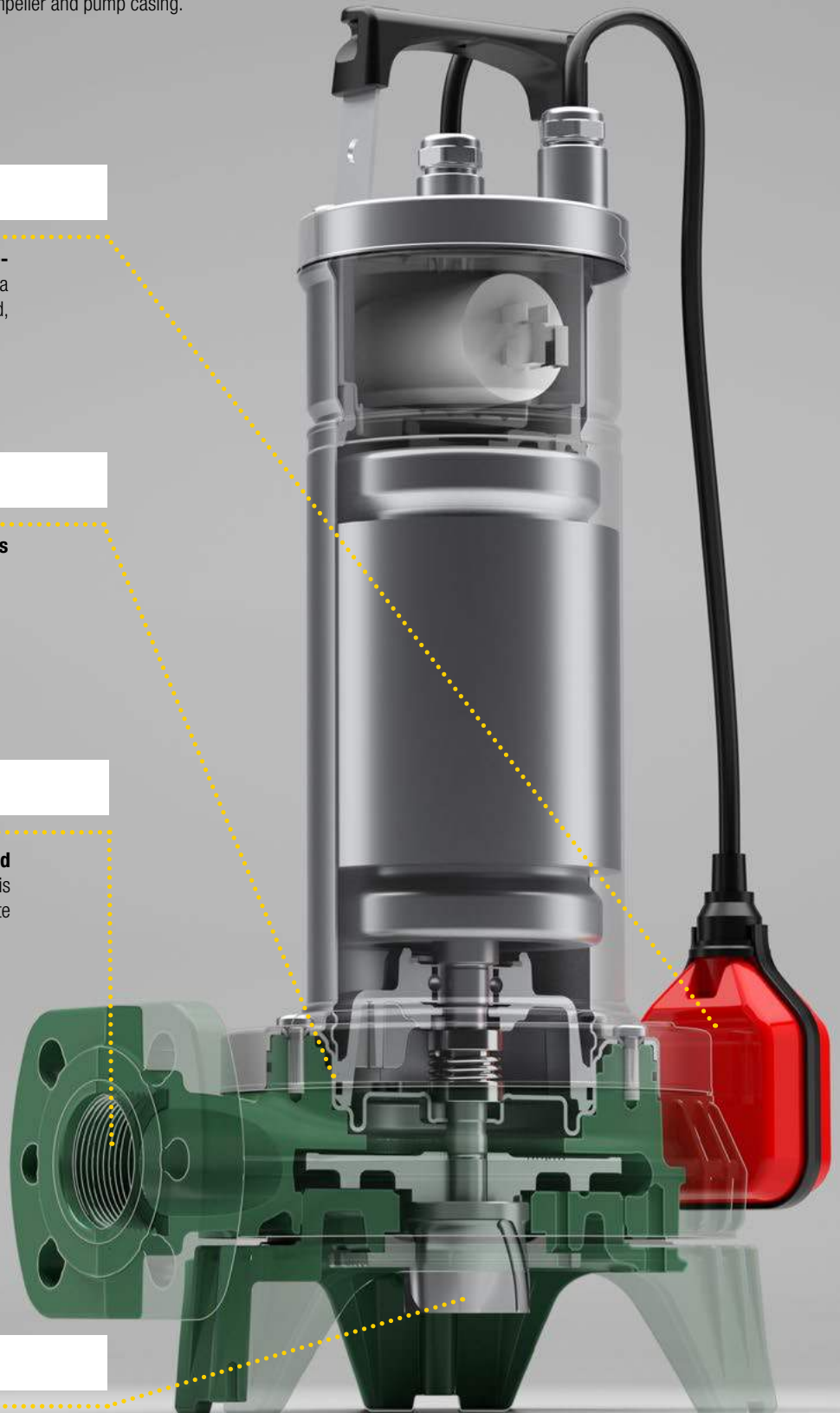

FEKA VS GRINDER

SELECTION TABLE



VERTICAL DISTANCE	OUTLET PIPE LENGTH DN 32 /40	FLOW	VERTICAL DISTANCE	OUTLET PIPE LENGTH DN 32 /40	FLOW
22 m	Max. 25/35 m	Q= 35/53 l/min (v = 0,7 m/s) DRAINAGE WATER	22 m	-	Q= 60/90 l/min (v = 1,2 m/s) SEWAGE WATER (with fecal matter)
20 m	Max. 90/120 m		20 m	-	
18 m	Max. 160/215 m		18 m	Max. 19/25 m	
16 m	Max. 225/305 m		16 m	Max. 40/55 m	
14 m	Max. 295/395 m		14 m	Max. 65/90 m	
12 m	Max. 360/485 m		12 m	Max. 90/120 m	
10 m	Max. 430/575 m		10 m	Max. 115/150 m	
8 m	Max. 495/665 m		8 m	Max. 135/185 m	
6 m	Max. 565/755 m		6 m	Max. 160/215 m	
4 m	Max. 630/850 m		4 m	Max. 185/250 m	
2 m	Max. 700/940 m	2 m	Max. 210/280 m		

Non-binding generic indication of the heights and lengths of the outlet pipes with a DN32 1 1/2" DN 40 internal diameter and the corresponding flow to achieve a self-cleaning speed of at least 0.7 m/s and to avoid sedimentation of solid material.

VERSIONS



STANDARD VERSION



WITH FLOAT

TECHNICAL DATA

MAXIMUM FLOW RATE	up to 14,4 m ³ /h
MAXIMUM HEAD	up to 25 m
P1	1,3 kW
P2 NOMINAL	1 Kw (1,3HP)
MAX LIQUID TEMPERATURE:	+40°C
OUTLET:	1" 1/2 GAS
OUTPUT FLANGE	DN 32 e DN 40
PUMPED LIQUID	sewage water, gray water
OUTLET DIRECTION	horizontal and vertical with curve kit accessory*

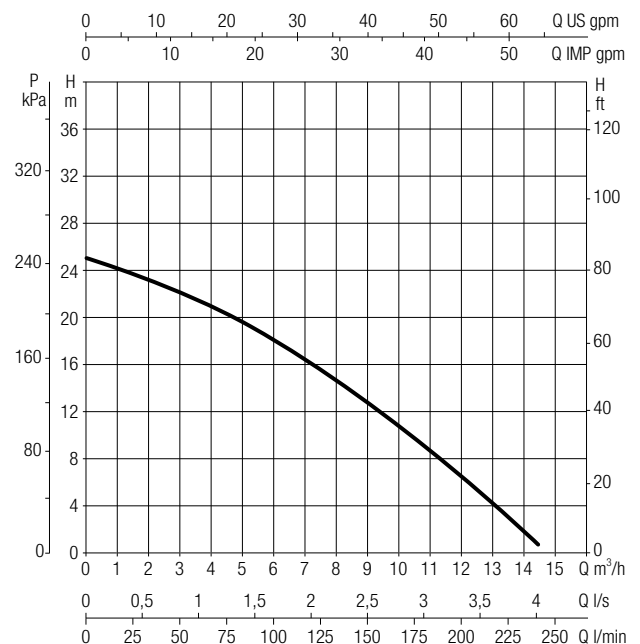



DAB PUMPS LTD.
6 Gilberd Court
Newcomen Way
Severalls Business Park
Colchester
Essex
CO4 9WN - UK
salesuk@dwtgroup.com
Tel. +44 0333 777 5010



DAB PUMPS IBERICA S.L.
Calle Verano 18-20-22
28850 - Torrejón de Ardoz - Madrid
Spain
Info.spain@dwtgroup.com
Tel. +34 91 6569545
Fax: + 34 91 6569676



DAB PUMPS (QINGDAO) CO. LTD.
No.40 Kaituo Road, Qingdao Economic
& Technological
Development Zone
Qingdao City, Shandong Province - China
PC: 266500
sales.cn@dwtgroup.com
Tel. +86 400 186 8280
Fax +86 53286812210



DAB PUMPS BV
'tHofveld 6 C1
1702 Groot Bijgaarden - Belgium
info.belgium@dwtgroup.com
Tel. +32 2 4668353



DAB PUMPS HUNGARY KFT.
H-8800
Nagykanizsa, Buda Ernő u.5
Hungary
Tel. +36 93501700



DAB PUMPS DE MÉXICO, S.A. DE C.V.
Av Amsterdam 101 Local 4
Col. Hipódromo Condesa,
Del. Cuauhtémoc CP 06170
Ciudad de México
Tel. +52 55 6719 0493



DAB PUMPS POLAND Sp. z o.o.
Ul. Janka Muzykanta 60
02188 Warszawa - Poland
polska@dabpumps.com.pl



DAB PUMPS B.V.
Albert Einsteinweg, 4
5151 DL Drunen - Nederland
info.netherlands@dwtgroup.com
Tel. +31 416 387280
Fax +31 416 387299



DAB PUMPS INC.
3226 Benchmark Drive
Ladson, SC 29456 - USA
info.usa@dwtgroup.com
Tel. 1- 843-797-5002
Fax 1-843-797-3366



DAB PUMPS OCEANIA PTY LTD
426 South Gippsland Highway,
Dandenong South VIC 3175 - Australia
info.oceania@dwtgroup.com
Tel. +61 1300 378 677



DAB PUMPS GMBH
Am Nordpark 3
D - 41069 Mönchengladbach - Germany
info.germany@dwtgroup.com
Tel. +49 2161 47388-0
Fax +49 2161 47388-36



DAB PUMPS SOUTH AFRICA (PTY) LTD
Twenty One industrial Estate,
16 Purlin Street, Unit B, Warehouse 4
Olifantsfontein -1667 - South Africa
info.sa@dwtgroup.com
Tel. +27 12 361 3997



PT DAB PUMPS INDONESIA
Satrio Tower lantai 26
unit C-D, Jl. Prof. Dr. Satrio Kav. C4,
Kel. Kuningan Timur, Kec. Setiabudi, Kota Adm.
Jakarta Selatan, Prov. DKI Jakarta. - Indonesia
Tel. +62 2129222850