

EVOPlus⁺

ELECTRONIC CIRCULATORS



EVOPLUS SMALL / EVOPLUS SMALL SAN

WET ROTOR ELECTRONIC CIRCULATORS



D CONNECT



EVOPLUS SMALL



EVOPLUS SMALL SAN

TECHNICAL DATA

Operating range: from 2 a 12 m³/h with head of up to 11 metres.
Pumped liquid temperature range: from -10 °C to +110 °C.
Pumped liquid: clean, free of solids and mineral oils, non-viscous, chemically neutral, with properties similar to water. (glycol max 30%).
Maximum operating pressure: 16 bar (1600 kPa).
Standard flanges: DN 32, DN 40 PN 6 / PN 10 / PN 16 (4 holes).
Maximum ambient temperature: + 40 °C.
Minimum suction pressure: the values are shown in the corresponding tables.
Accessories: ½" F, ¾" F, 1" F, 1" ¼ F, 1" ¼ M union connectors. DN 32 PN 10 and DN 40 PN 10 threaded counter flanges.
Electromagnetic compatibility: EVOPLUS circulator comply with EN 61800-3 standard, category C2, as far as electromagnetic compatibility.
Electromagnetic emissions: Residential environment (containment measures might be required in some cases).
Conducted emissions: Residential environment (containment measures might be required in some cases).
Circulator protection class: IP 44.
Insulation class: F.
Standard voltage: single-phase 220-240 V, 50/60 Hz.
Sound pressure values: ≤ 33 dB(A).
Product compliant with European Standards EN 61800-3 – EN 60335-1 – EN 60335-2-51

APPLICATIONS

EVOPLUS circulation electronic pumps can be used in heating, ventilation, and air conditioning systems for residential and commercial buildings, like:

- Large residential buildings
- Condominiums and small apartment buildings
- Homes
- Real estate buildings
- Private and public hospitals
- Schools
- Office buildings

Single version available, with 1 ½" e 2" threaded ports, and with DN 32 and DN 40, PN 6 / PN 10 / PN 16 flanged ports.

Twin version available with DN 32 and DN 40, PN 6 / PN 10 / PN 16 flanged pump body.

Special version available with bronze pump body for the recirculation of sanitary water.

Possibility of 0-10 V or PWM external signal control, and connection to ModBus management systems (LonBus with appropriate additional communication module), with the use of the optional Multifunction module (supplied as standard for the twin version). **You can remotely control the single version thanks to the Dconnect service** (with Dconnect box supplied separately).

HEATING SYSTEM APPLICATIONS

The heating required for the different applications varies significantly during day and night, due to the external temperature, or the degree of occupancy inside the areas. To the above, one must add the different needs of the various environments, and the opening or closing of the various circuit branches of complex systems. Electronic wet rotor pumps ensure at all times, and virtually in all correctly sized systems, a sufficient level of energy, together with a quieter operation, and more comfort, together with an important reduction of operating costs.

AIR CONDITIONING APPLICATIONS

Unlike conventional electronic pumps, EVOPLUS electronic circulators can be used also in air conditioning systems where the temperature of the pumped liquid is lower than the room temperature. In these conditions, condensation tends to form on the outer surface of the circulator, which however does not affect the operation of the electronic and the mechanical components. The unit is designed and sized in such a way that it allows condensation to drain without damage to the construction components.

SANITARY RECIRCULATION APPLICATIONS

The SAN version, with bronze pump body, was specifically developed for the recirculation of sanitary water. With the constant temperature mode of operation, the temperature inside the recirculation piping is controlled without the need for thermostat valves, therefore optimizing comfort.

CONSTRUCTION FEATURES

Monobloc circulation pump consisting of the cast iron hydraulic section, and the wet rotor synchronous motor. Aluminium motor casing. Scroll type pump body featuring high hydraulic efficiency thanks to highly precise design and smooth internal surfaces. In-line suction and delivery ports. The single version is supplied as standard with insulating casing, to avoid heat dispersion and/or the formation of condensation on the pump body. For the twin version, the insulation must be provided by the installer. In any case, pay attention not to obstruct the condensation drainage ducts, to avoid impairing the operation of the circulator. The EVOPLUS circulators for small collective systems are connected to the power input line using a practical connector with plug supplied as standard, which makes the operation quick and easy. Technopolymer impeller, aluminium motor shaft on graphite bushings lubricated by the pumped liquid. Stainless steel rotor protection liner. Ceramic thrust ring, ethylene-propylene seal rings and carbon fibre composite stator liner. Asynchronous motor with permanent magnet rotor. The twin version features an automatic swing check valve incorporated in the delivery port, to avoid water recirculating through the unit when this is not running; in addition, a blank flange is also supplied as standard, to allow either of the two motors to be removed for servicing. PN 16 standard pump body execution, flanged with 4 holes, compatible with PN 6 / PN 10 / PN 16 counter flanges, to ensure the interchangeability of the pumps in existing systems.

DCONNECT SERVICE

REMOTE CONTROL FOR ELECTRONIC RESIDENTIAL AND COMMERCIAL SYSTEMS

The Dconnect service offers simple and intuitive remote control of your installation, without the need of a server or specialist personnel.

With Dconnect, you can remotely manage your installations as if you were right in front of them.

Thanks to the system operation charts, you will also be able to optimise operation. You will also receive prompt notifications of any system faults.

THE CONNECTIVITY SERVICE ALLOWS YOU TO:

EASILY MONITOR YOUR SYSTEMS

The installations with green status are OK, while the orange ones need attention, and the red ones are experiencing problems

The screenshot shows the 'Installation list' section of the DCONNECT service. It features a grid of eight installation cards, each with a monitor icon and a status indicator. The status indicators are green checkmarks, indicating that all systems are OK. The installations listed are:

- Impianto di pressurizzazione via Cairoli Pisa (STATUS ✓)
- Condominio Cancelli Palala (STATUS ⚠)
- Condominio Pero Livorno (STATUS ✓)
- Condominio Nicolai Firenze (STATUS ✓)
- Officine Arnoldi Pressurizzazione (STATUS ✓)
- Officine Arnoldi Riscaldamento (STATUS ✓)
- Officine Arnoldi Acqua Calda Sanitaria (STATUS ✓)
- Officine Arnoldi gruppi frigo (STATUS ✓)

TAKE ANY NECESSARY ACTIONS AS IF YOU WERE RIGHT IN THE PUMP ROOM

Using the internet site or the APPs, you will be able to easily and quickly control your systems.

The screenshot shows the detailed control interface for an EVOPLUS SMALL pump. It includes a product image, name, description, and serial number. The status is 'Run' and the time elapsed from the last received data is 'less than 3m'. A 'Status' dropdown menu is visible. The main control area consists of several monitoring cards:

- SYSTEM ERROR STATUS:** System OK (Warning icon)
- HEAD:** 1.2 m (Gear icon)
- PUMP STATUS:** Run (Power icon)
- ESTIMATED FLOW:** 0.8 m³/h (Flow icon)
- POWER:** 9 W (Lightning bolt icon)
- RPM:** 1510 rpm (Speedometer icon)
- CURRENT:** 110 mA (Gauge icon)
- RUN TIME PUMP:** - h (Clock icon)
- BOARD TEMPERATURE:** - °C (Thermometer icon)
- LIQUID TEMPERATURE:** - °C (Thermometer icon)
- LIQUID TEMPERATURE 2:** - °C (Thermometer icon)
- HEATSINK TEMPERATURE:** - °C (Thermometer icon)
- LINE VOLTAGE:** 228 V (Voltage icon)

DCONNECT SERVICE

REMOTE CONTROL FOR ELECTRONIC RESIDENTIAL AND COMMERCIAL SYSTEMS

In order to use the Dconnect service, registration and connected products are required.

Connect to the website: <https://dconnect.dabpumps.com>, using Internet Browsers such as Microsoft Edge or Google Chrome.

The Android and iOS Dconnect APPs can be downloaded from the relevant Stores:



REMOTE ALARMS

In case of alarm, the Dconnect service will promptly send you a notification, so that you can check what is happening and organise a visit to the system before the issue becomes an emergency for your customer.

WHAT PRODUCTS CAN YOU MANAGE USING THE DCONNECT SERVICE?

MCE/P, MCE/C, ADAC, Active driver Plus, Ebox, Evoplus, Esybox, Esybox mini, Esybox Diver, Dtron 3.

WHAT DO YOU NEED TO USE THE SERVICE?

1. DConnect Box
2. Cables for the connection of the DConnect Box / Dconnect Box 2 to the products to control
3. One or more compatible products
4. An internet connection in the system to control

For more information visit: internetofpumps.com

EVOPLUS SMALL / EVOPLUS SMALL SAN

WET ROTOR ELECTRONIC CIRCULATORS

EVOPLUS CONSTRUCTION CHARACTERISTICS FOR SMALL COLLECTIVE SYSTEMS (ELECTRONIC DEVICE).

EVOPLUS circulators are controlled by a latest generation NPT technology IGBT device, for better efficiency and strength. The specific features are:

- Sensorless motor control
- Sine-wave PWM modulation
- High carrier frequency, to eliminate all audio band noise
- dedicated 32 bit processor
- Optimised "space vector" algorithm

An intuitive and functional user interface guarantees ease of calibration by all users. The easy to read OLED display on the control panel, 4 simple navigation keys, an in-line cascade menu featuring the latest mobile technology trends, and a wide range of functions, mean that EVOPLUS circulators are truly revolutionary products. A reliable and sturdy construction, together with a modern and innovative design, complete the product, also in terms of aesthetic value. This range is ready for the following remote commands through expansion modules:

Base Module

- Economy mode
- Circulator start/stop
- Presence/absence of system alarms
- Pump in operation notification

Multifunction Module*

- 2 x 0-10 V analogue signals
- 1 PWM signal
- 1 ΔT analogue signal from temperature sensor
- Connection to ModBus system management devices
- Optional LonBus with appropriate module
- Presence/absence of system alarms
- Pump in operation notification

* Inputs available only if the associated function is active

MATERIALS

N.	PARTS	MATERIALS
1	PUMP BODY	CAST IRON 250 UNI ISO 185 - CTF BRONZE (for the SAN version)
4	IMPELLER	TECHNOPOLYMER
7A	MOTOR SHAFT	ALLUMINA
7B	ROTOR	STAINLESS STEEL LINER
8	STATOR	-
10	MOTOR CASING	DIE-CAST ALUMINIUM
127	SEAL RING	EPDM RUBBER
128	STATOR LINER	STAINLESS STEEL
130	CLOSING FLANGE	STAINLESS STEEL
131	THRUST RING SUPPORT	EPDM RUBBER
132	BUSHINGS	GRAPHITE

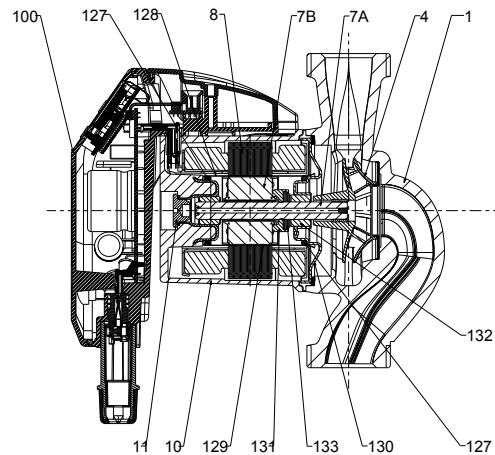

- Legend: (example)

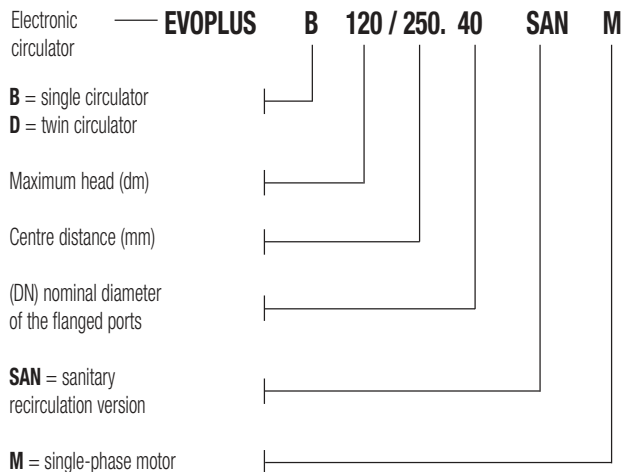
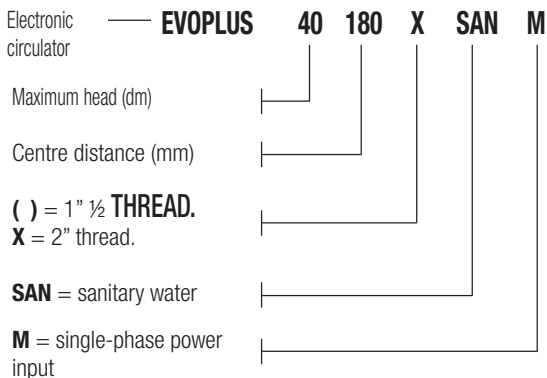

EVOPLUS SMALL / EVOPLUS SMALL SAN

WET ROTOR ELECTRONIC CIRCULATORS

MODES OF OPERATION

All the functions listed below can be consulted by the users (including less experienced ones) by simply scrolling through the menu. The calibration and the modification of the parameters are protected, and can only be completed by expert users. The factory settings of the EVOPLUS range are for proportional differential pressure control mode in the curve that ensures the best energy efficiency index (EEI).

1 - $\Delta P-v$ proportional differential pressure adjustment mode

With $\Delta P-v$ adjustment mode, with the variation of the flow rate, the value of the delivery of the head also varies in a linear manner, from H_{setp} to $H_{setp}/2$.

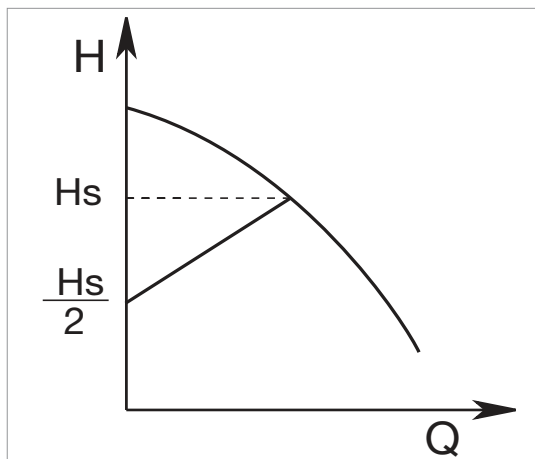

This adjustment is particularly indicated for the following systems:

a. Two-pipe heating systems with thermostat valves and with:

- head greater than 4 metres;
- very long circuit piping;
- valves with wide operating range;
- differential pressure regulators;
- high pressure drops in those parts of the system carrying the entirety of the water flow rate;
- low differential pressure.

b. Under-floor central heating systems with thermostatic valves and significant pressure drops in the boiler circuit.

c. Systems with primary circuit pumps with high pressure drops.

Example of set-up of the set-point with $\Delta P-v$

The following operating point is required:

$$Q = 6,5 \text{ m}^3/\text{h}$$

$$H = 6 \text{ m}$$

PROCEDURE:

1. In the graph, find the desired operating point, and then find the EVOPLUS curve closest to it (in this case the point lies precisely on the curve)
2. Follow the curve upwards until reaching the intersection with the limit curve of the circulator.
3. The head reading found at this limit point is the set-point head that must be entered to obtain the desired operating point.

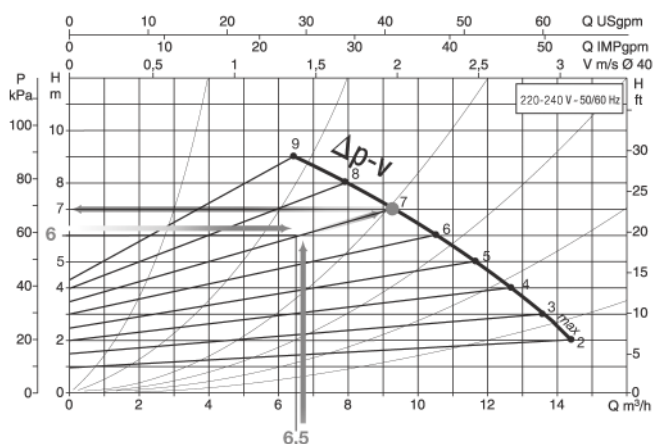

2 - $\Delta P-c$ constant differential pressure adjustment mode

The $\Delta P-c$ adjustment mode keeps the differential pressure of the system constantly at the H_{setp} value set, even in case of variation of the flow rate.

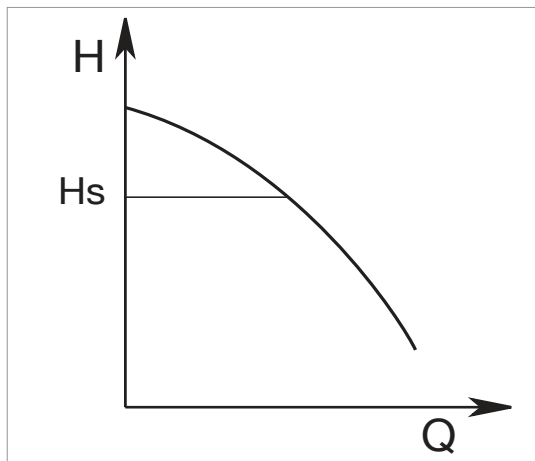

This adjustment is particularly indicated for the following systems:

a. Two-pipe heating systems with thermostat valves and with:

- head lower than 2 metres;
- natural circulation;
- low pressure drops in those parts of the system carrying the entirety of the water flow rate;
- high differential temperature (central heating).

b. underfloor heating systems with thermostat valves

c. single-pipe heating systems with thermostat valves and calibration valves

d. Systems with primary circuit pumps with low pressure drops.

EVOPLUS SMALL / EVOPLUS SMALL SAN

WET ROTOR ELECTRONIC CIRCULATORS

3 - Constant curve adjustment modes

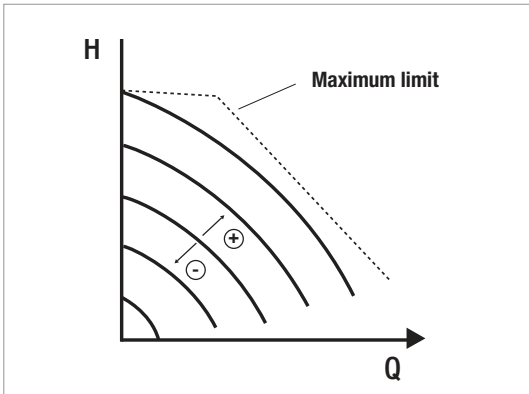

In this control mode, the circulator works based on constant speed characteristic curves. The operation curve is selected by setting the rotation speed using a percentage factor. The 100 % value indicates the maximum limit curve. The actual rotation speed may be affected by the power and differential pressure limitations of the actual circulator model. The rotation speed may be set using the display, or either a 0-10 V or PWM external signal, using the appropriate multifunction module.

Control mode indicated for constant flow rate heating and air conditioning systems.

4 - Constant differential pressure control mode with proportional control based on the water temperature (Function available with multifunction module)

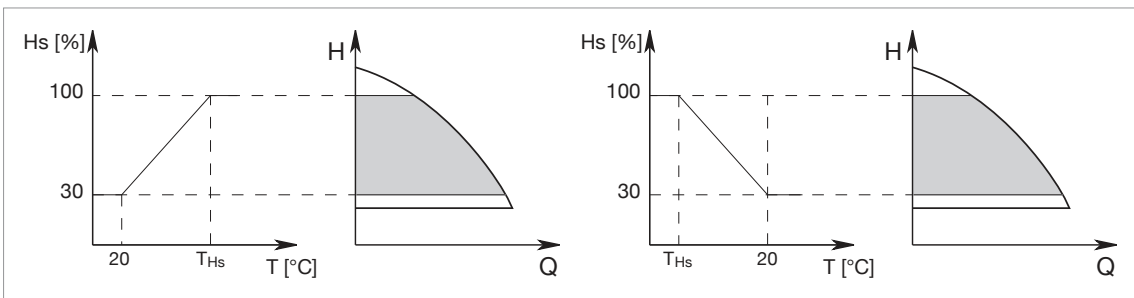

The circulator head set-point is reduced in accordance with the water temperature. The liquid temperature can be set between 0 °C to 100 °C.

This adjustment is particularly indicated for the following systems:

- in variable flow rate systems (two-pipe central heating systems), in which a further reduction of circulator performance is provided in line with the lowering of the temperature of the circulating liquid, in case of reduced heating demand.
- in constant flow rate systems (single-pipe and under-floor central heating systems), where the performance of the circulator can only be adjusted by activating the temperature influence function.
It is set through the EVOPLUS control panel.

5 - ΔT -c constant differential pressure control mode (Function available with multifunction mode) *

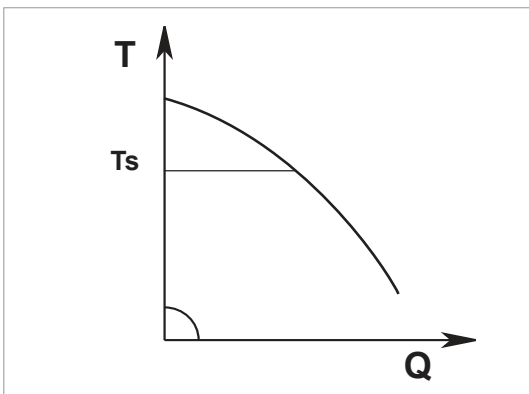

The ΔT -c control mode keeps the pumped liquid at constant temperature, changing the flow rate to the Tsetp settable value.

This adjustment is particularly indicated for the following systems:

- Under-floor heating systems.
- systems with primary circuit pumps.
- Systems with circuit pumps with heat exchanger.
- Solar energy systems with storage tanks.
- Solar panel swimming pool heating systems.

* Adjustment during implementation.

ECONOMY MODE

The economy function can be set directly on the control panel, by setting a reduction value (f.rid), the maximum value of which can be 50%. In all the previously listed settings, the Hset value must be replaced with an Hset x f.rid.

EVOPLUS SMALL / EVOPLUS SMALL SAN

WET ROTOR ELECTRONIC CIRCULATORS

BASE MODULE

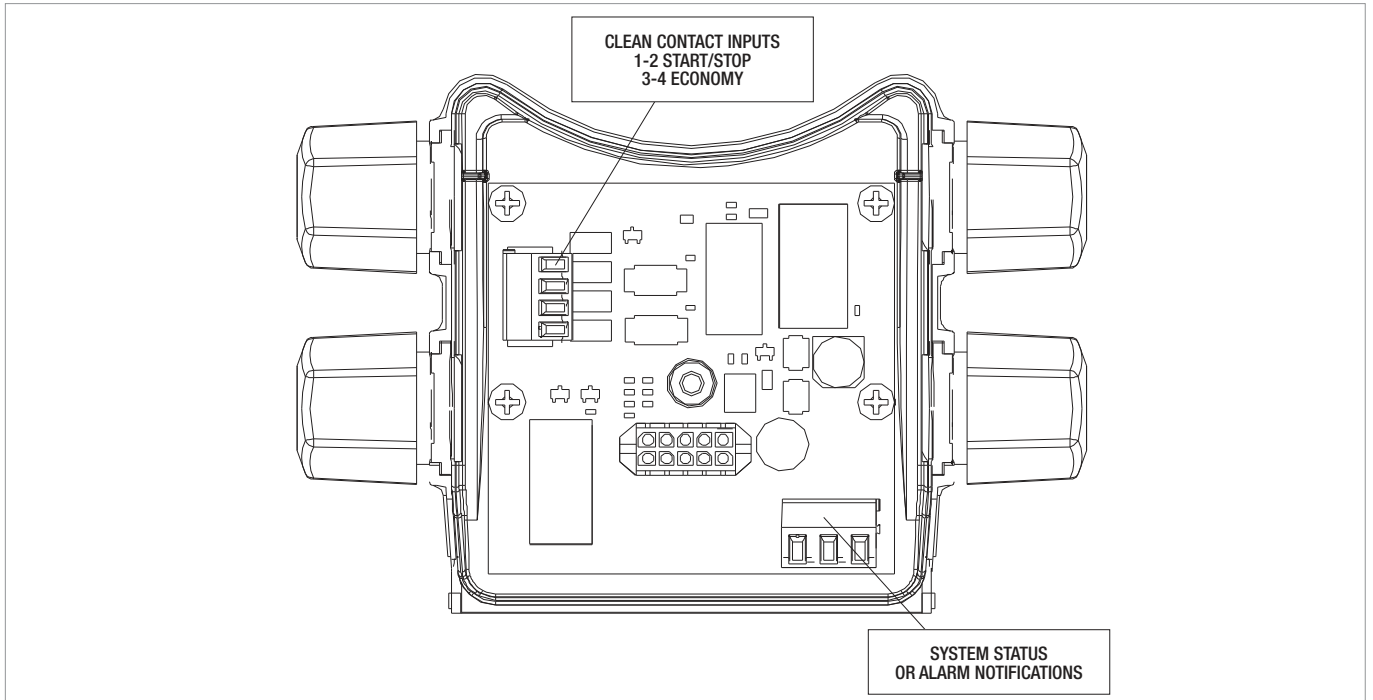

Digital inputs

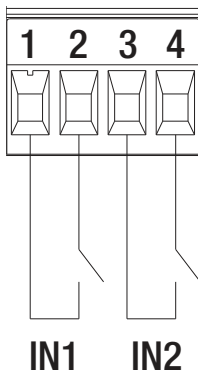

Clean contact inputs
1-2 START/STOP
3-4 ECONOMY

Input	Terminal no.	Type of contact	Associated function
IN1	1	Clean contact	EXT: If it is activated from the control panel, it will be possible to remotely control the switching on and off of the pump.
	2		
IN2	3	Clean contact	Economy: If it is activated from the control panel, it will be possible to remotely activate the set-point reduction function.
	4		

If the **EXT** and **Economy** functions have been activated using the control panel, the system will behave as follows:

IN1	IN2	System status
Open	Open	Pump stopped
Open	Close	Pump stopped
Close	Open	Pump in operation with set-point set by the user
Close	Close	Pump in operation with reduced set-point

Digital outputs

System status or alarm notifications

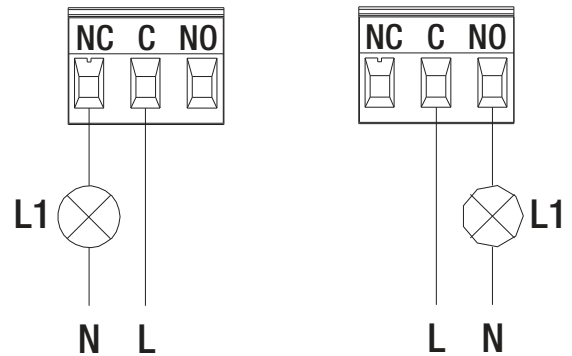

The function associated to OUT1 is "Alarms Present"; L1 turns on when a system alarm is present, and turns off when no fault is detected.

The function associated with OUT1 is "Pump Status"; L1 turns on when the pump is in operation, and stops when the pump is idle.

Output	Terminal no.	Type of contact	Associated function
OUT1	NC	NC	<ul style="list-style-type: none"> • Presence/absence of system alarms • Pump in operation/Pump stopped
	C	COM	
	NO	NO	

The OUT1 output is available on the 3-pole removable terminal box, where the type of contact is also shown (NC = Normally Closed, COM = Common, NO = Normally Open).

Characteristics of the output contacts	
Max sustainable voltage [V]	250
Max sustainable current [A]	5 - If resistive load 2,5 - If inductive load
Max cable section accepted [mm ²]	1,5

EVOPLUS SMALL / EVOPLUS SMALL SAN

WET ROTOR ELECTRONIC CIRCULATORS

MULTIFUNCTION MODULE

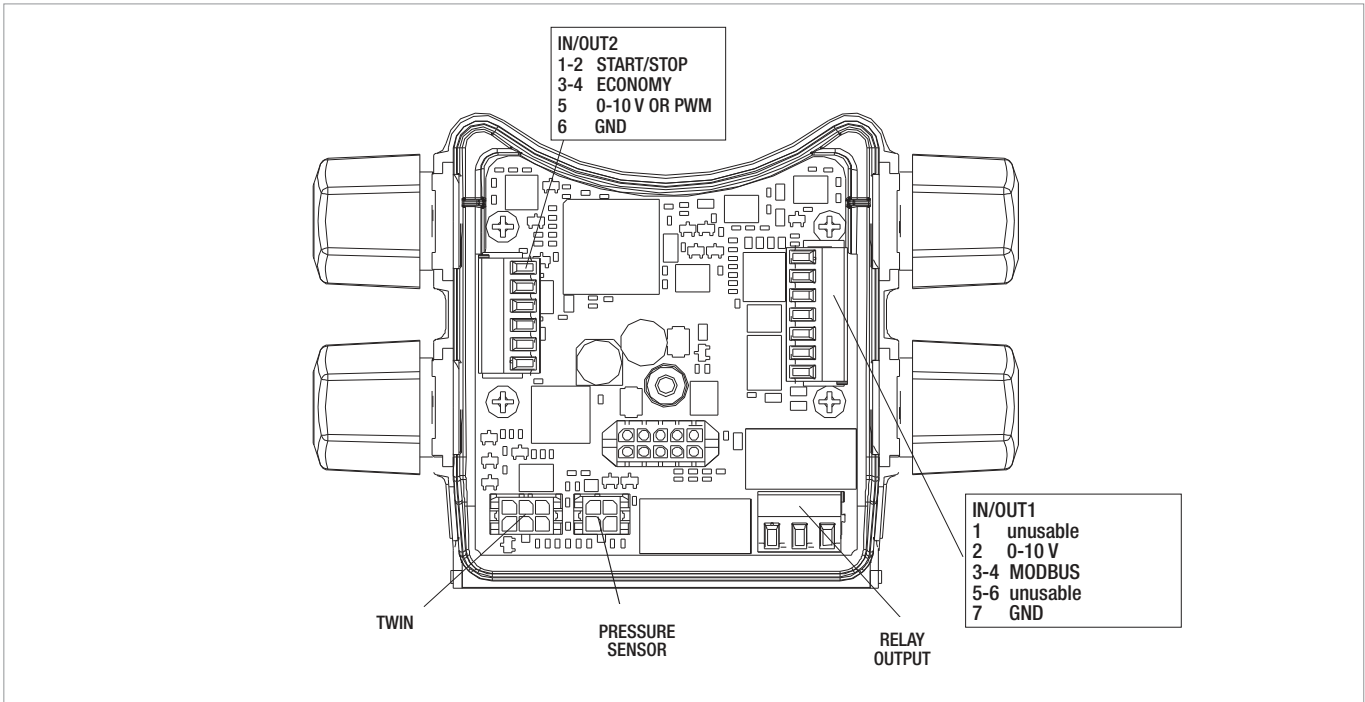

Digital inputs

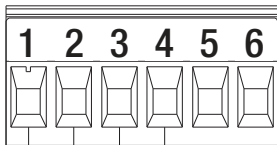

IN/OUT2
 1-2 START/STOP
 3-4 ECONOMY
 5 0-10V, PWM and NTC
 6 GND

IN1 IN2

Input	Terminal no.	Type of contact	Associated function
IN1	1	Clean contact	EXT: If it is activated from the control panel, it will be possible to remotely control the switching on and off of the pump.
	2		
IN2	3	Clean contact	Economy: If it is activated from the control panel, it will be possible to remotely activate the set-point reduction function.
	4		

If the **EXT** and **Economy** functions have been activated using the control panel, the system will behave as follows:

IN1	IN2	System status
Open	Open	Pump stopped
Open	Close	Pump stopped
Close	Open	Pump in operation with set-point set by the user
Close	Close	Pump in operation with reduced set-point

MODBUS

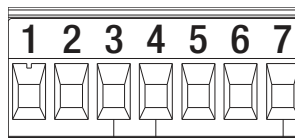

IN/OUT1
 1 unusable
 2 0-10 V
 3-4 modbus
 5-6 unusable
 7 GND

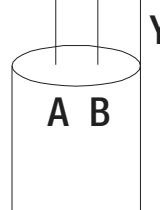

The multifunction expansion module provides serial communication through an RS-485 input. The communication is established in accordance with the MODBUS specifications.

Using the MODBUS, it is possible to remotely set the circulator operating parameters, like the desired differential pressure, the control mode, etc. At the same time, the circulator can provide important information on the status of the system.

Modbus terminals	Terminal no.	Description
A	3	Terminal not inverted (+)
B	4	Terminal inverted (+)
Y	7	GND

LONBUS

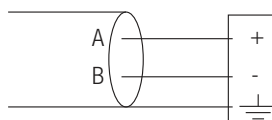

Gateway/ Evoplus connection

Using some modules available on the market, the circulator, and therefore its status, can also be made available to a LonWorks network. It will then be possible to change the parameters of the circulator by reading and amending the registers as indicated in the "Modbus Protocol instruction manual", available at the following address: "<http://www.dabpumps.it/evoplus>".

EVOPLUS SMALL / EVOPLUS SMALL SAN

WET ROTOR ELECTRONIC CIRCULATORS

PWM AND NTC ANALOGUE INPUT

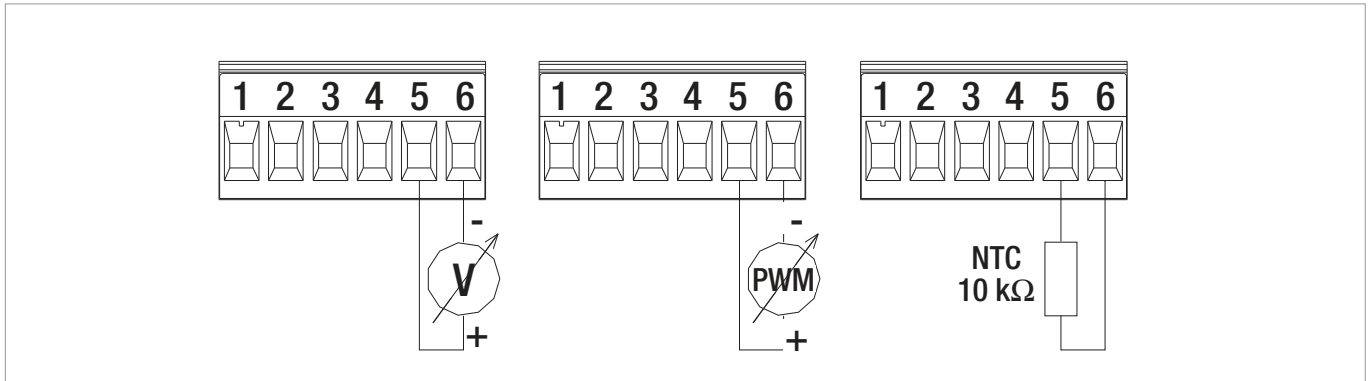

DIGITAL OUTPUTS

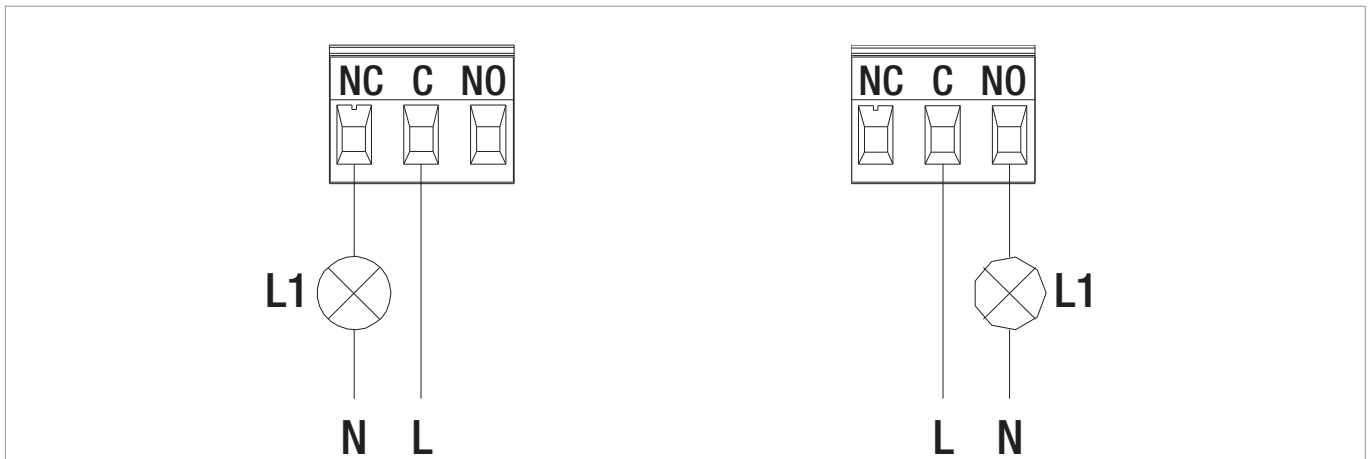

The function associated with OUT1 is "Pump Status"; L1 turns on when the pump is in operation, and stops when the pump is idle.

The function associated to OUT1 is "Alarms Present"; L1 turns on when a system alarm is present, and turns off when no fault is detected.

Output	Terminal no.	Type of contact	Associated function
OUT1	NC	NC	<ul style="list-style-type: none"> • Presence/absence of system alarms • Pump in operation/Pump stopped
	C	COM	
	NO	NO	

The OUT1 output is available on the 3-pole removable terminal box, where the type of contact is also shown (NC = Normally Closed, COM = Common, NO = Normally Open).

Characteristics of the output contacts	
Max sustainable voltage [V]	250
Max sustainable current [A]	5 - If resistive load 2,5 - If inductive load
Max cable section accepted [mm ²]	1,5

EVOPLUS RANGE

WET ROTOR ELECTRONIC CIRCULATORS

PERFORMANCE RANGE

The performance curves are based on kinematic viscosity values = 1 mm²/s and density equal to 1000 kg/m³. Curve tolerance according to ISO 9906.

GRAPHIC SELECTION TABLE

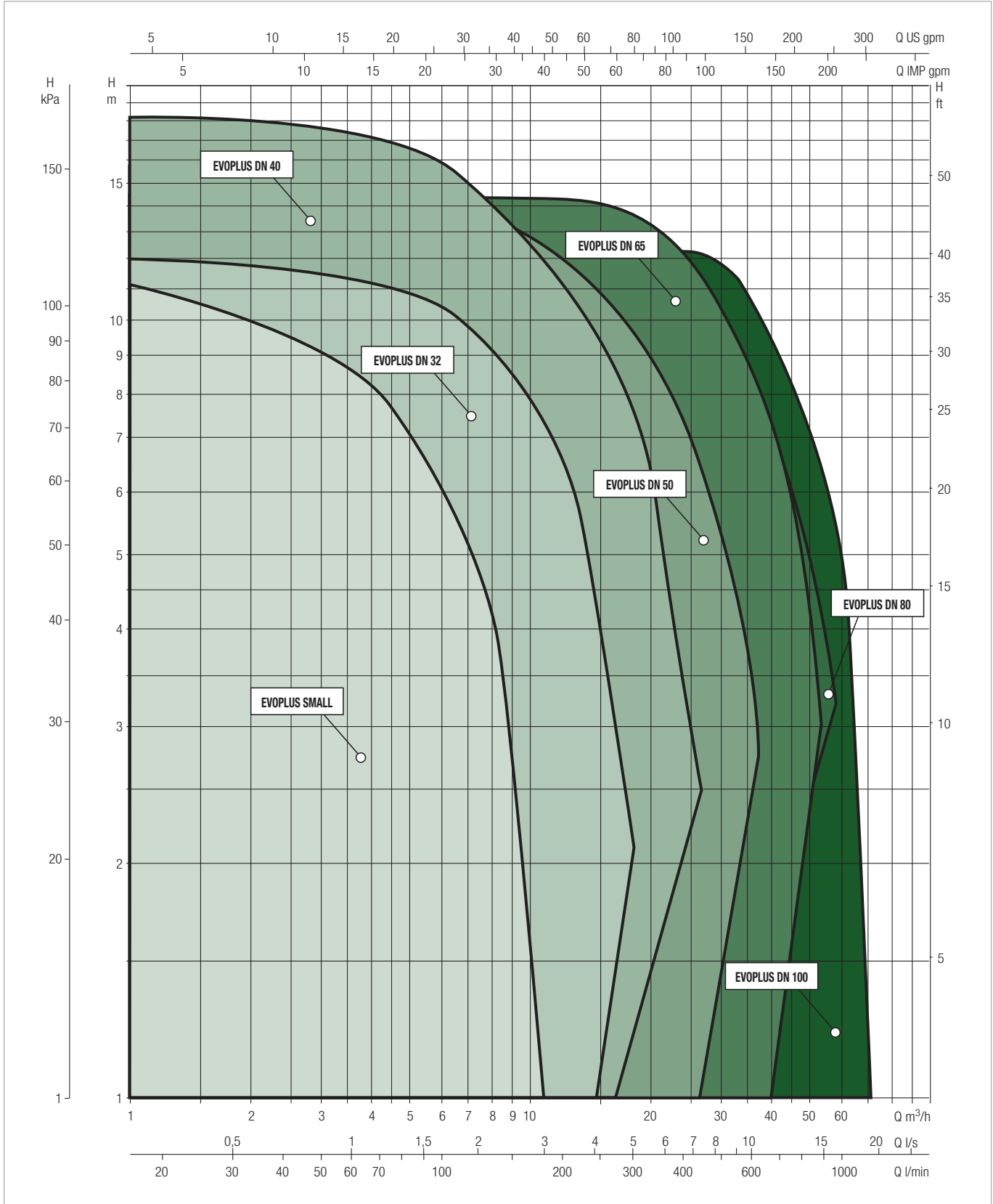

EVOPLUS SMALL / EVOPLUS SMALL SAN

WET ROTOR ELECTRONIC CIRCULATORS

SELECTION TABLE - EVOPLUS SMALL

MODEL	Q=m ³ h	0	2,4	3	4,2	5,4	7,2	9,6
	Q=l/min	0	40	50	70	90	120	160
EVOPLUS 40/180 M	H (m)	4,2	4,2	4	3,1	2,4		
EVOPLUS 60/180 M		6,1	6,1	5,8	4,6	3,4		
EVOPLUS 80/180 M		8,2	8,2	7,7	6,2	4,8	2,9	
EVOPLUS 110/180 M		11,1	10,1	9,2	7,5	5,9	3,9	
EVOPLUS 40/180 XM		4,1	4,1	4	3,1	2,2		
EVOPLUS 60/180 XM		6,1	6,1	5,7	4,5	3,4		
EVOPLUS 80/180 XM		8,1	8,1	7,6	6,2	4,9	3	
EVOPLUS 110/180 XM		11,3	10,2	9,5	7,9	6,3	4,3	2
EVOPLUS B 40/220.32 M		4,2	4,2	4,2	3,3	2,5	1,3	
EVOPLUS B 60/220.32 M		6,1	6,1	5,6	4,6	3,6	2,2	
EVOPLUS B 80/220.32 M		8	8	7,3	6	4,9	3,3	
EVOPLUS B 110/220.32 M		11,2	10,5	9,6	8,1	6,8	5	2,6
EVOPLUS B 40/250.40 M		4,2	4,2	4,2	3,3	2,5	1,3	
EVOPLUS B 60/250.40 M		6,1	6,1	5,6	4,6	3,6	2,2	
EVOPLUS B 80/250.40 M		8	8	7,3	6	4,9	3,3	
EVOPLUS B 110/250.40 M		11,2	10,5	9,6	8,1	6,8	5	2,6
EVOPLUS D 40/220.32 M		4,2	4,2	4,2	3,3	2,5	1,3	
EVOPLUS D 60/220.32 M		6,1	6,1	5,6	4,6	3,6	2,2	
EVOPLUS D 80/220.32 M		8	8	7,3	6	4,9	3,3	
EVOPLUS D 110/220.32 M		11,2	10,5	9,6	8,1	6,8	5	2,6
EVOPLUS D 40/250.40 M		4,2	4,2	4,2	3,3	2,5	1,3	
EVOPLUS D 60/250.40 M		6,1	6,1	5,6	4,6	3,6	2,2	
EVOPLUS D 80/250.40 M		8	8	7,3	6	4,9	3,3	
EVOPLUS D 110/250.40 M		11,2	10,5	9,6	8,1	6,8	5	2,6

SELECTION TABLE - EVOPLUS SMALL SAN

MODEL	Q=m ³ h	0	2,4	3	4,2	5,4	7,2	9,6
	Q=l/min	0	40	50	70	90	120	160
EVOPLUS 40/180 SAN M	H (m)	4,2	4,2	4	3,1	2,4		
EVOPLUS 60/180 SAN M		6,1	6,1	5,8	4,6	3,4		
EVOPLUS 80/180 SAN M		8,2	8,2	7,7	6,2	4,8	2,9	
EVOPLUS 110/180 SAN M		11,1	10,1	9,2	7,5	5,9	3,9	
EVOPLUS B 40/220.32 SAN M		4,2	4,2	4,2	3,3	2,5	1,3	
EVOPLUS B 60/220.32 SAN M		6,1	6,1	5,6	4,6	3,6	2,2	
EVOPLUS B 80/220.32 SAN M		8	8	7,3	6	4,9	3,3	
EVOPLUS B 110/220.32 SAN M		11,2	10,5	9,6	8,1	6,8	5	2,6
EVOPLUS B 40/250.40 SAN M		4,2	4,2	4,2	3,3	2,5	1,3	
EVOPLUS B 60/250.40 SAN M		6,1	6,1	5,6	4,6	3,6	2,2	
EVOPLUS B 80/250.40 SAN M		8	8	7,3	6	4,9	3,3	
EVOPLUS B 110/250.40 SAN M		11,2	10,5	9,6	8,1	6,8	5	2,6

EVOPLUS SMALL - WET ROTOR ELECTRONIC CIRCULATORS

Pumped liquid temperature range: from -10 °C to +110 °C - Maximum operating pressure: 16 bar (1600 kPa)

EVOPLUS 40/180 M

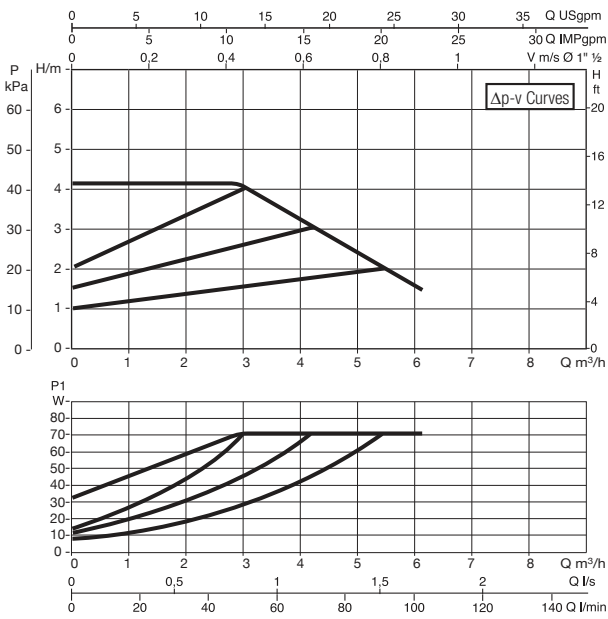

EVOPLUS 60/180 M

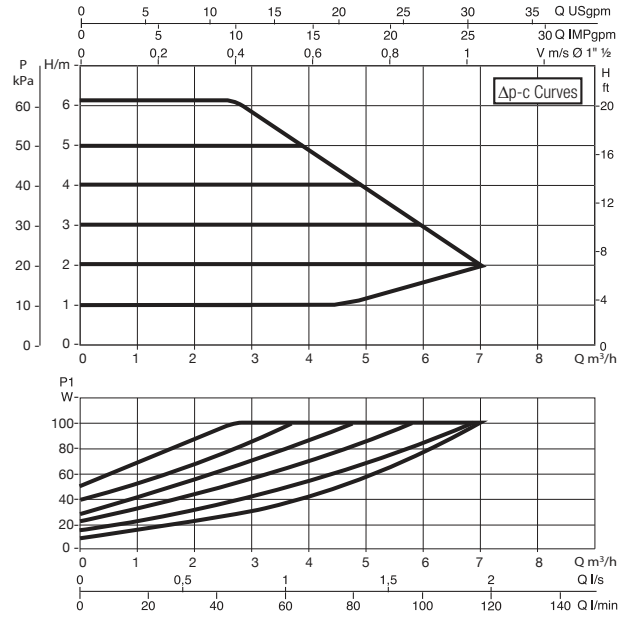
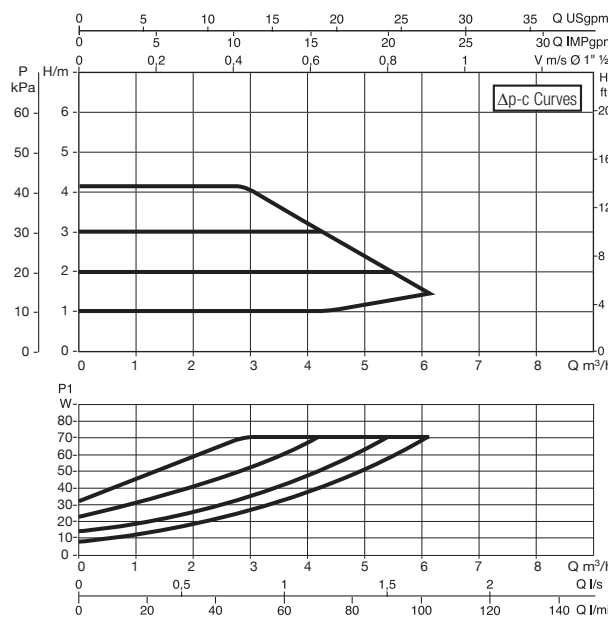
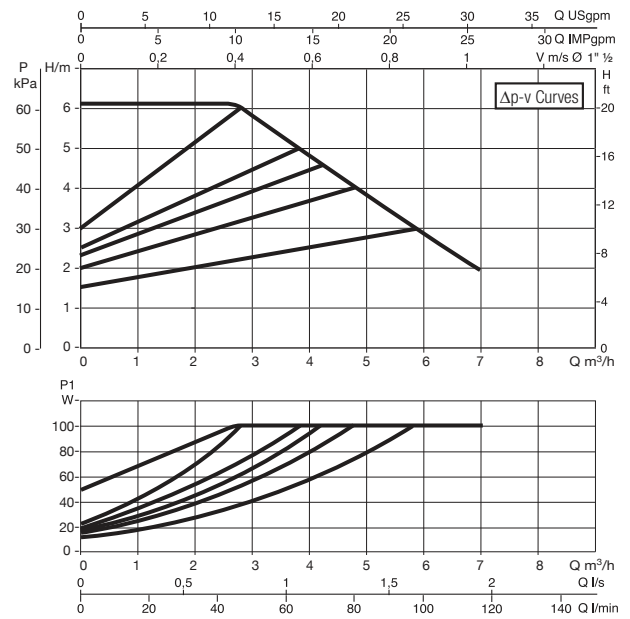

The curves are based on kinematic viscosity values = 1 mm²/s and density equal to 1000 kg/m³. Curve tolerance according to ISO 9906. Fixed speed curves available on the DNA.

MODEL	CENTRE DISTANCE mm	UNIONS ON REQUEST		COUNTERFLANGES ON REQUEST	POWER INPUT 50/60 Hz	P1 MAX W	In A	EEI*	MINIMUM SUCTION PRESSURE			WEIGHT Kg
		STANDARDISED	SPECIAL						t°	90°	100°	
EVOPLUS 40/180 M	180	1" F	¾" F - 1¼" M	-	220/240 V	68	0,52	EEI ≤ 0,20	m.c.w.	20	25	4,5
EVOPLUS 60/180 M	180	1" F	¾" F - 1¼" M	-	220/240 V	100	0,72	EEI ≤ 0,20	m.c.w.	20	25	4,5

The parameter of reference for the more efficient circulators is EEI ≤ 0,20.

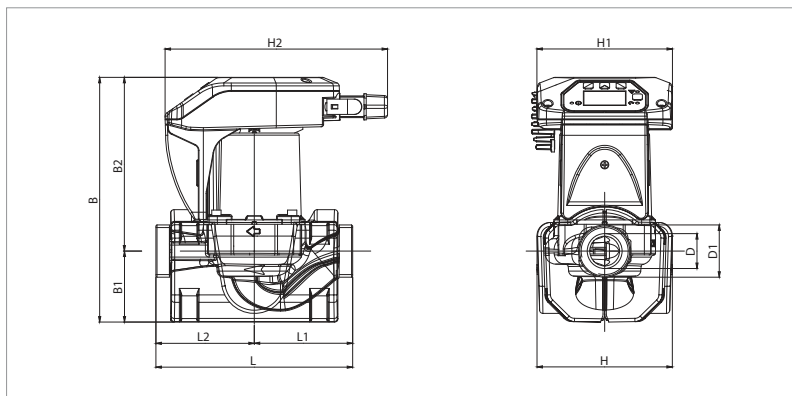

L	L1	L2	B	B1	B2
180	90	90	224	65	159

D	D1	H	H1	H2
32	1½	124	124	204

EVOPLUS SMALL - WET ROTOR ELECTRONIC CIRCULATORS

Pumped liquid temperature range: from -10 °C to +110 °C - Maximum operating pressure: 16 bar (1600 kPa)

EVOPLUS 80/180 M

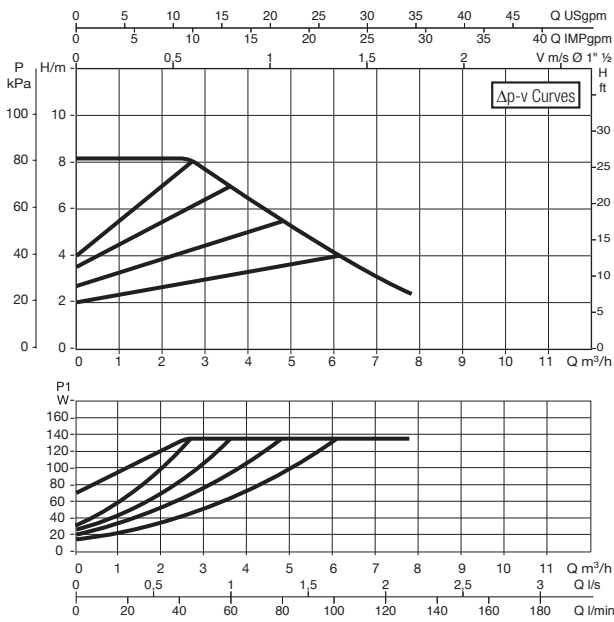

EVOPLUS 110/180 M

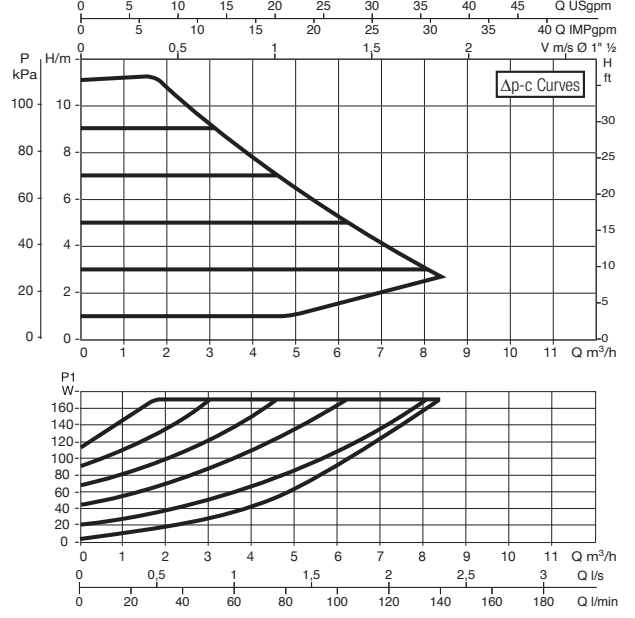
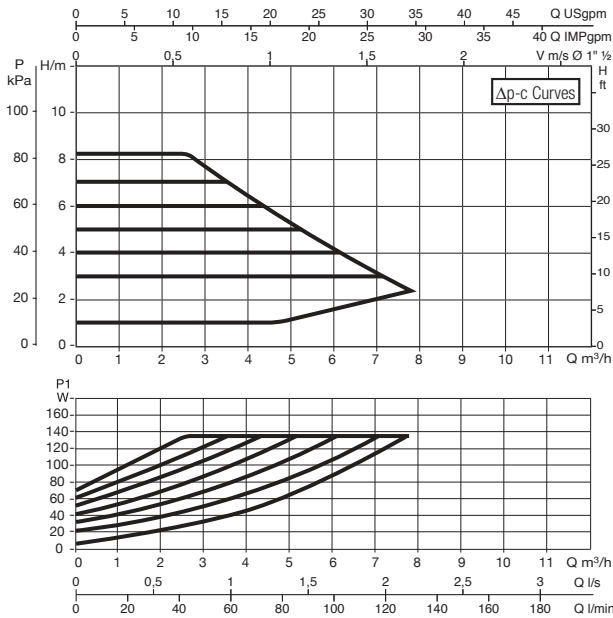
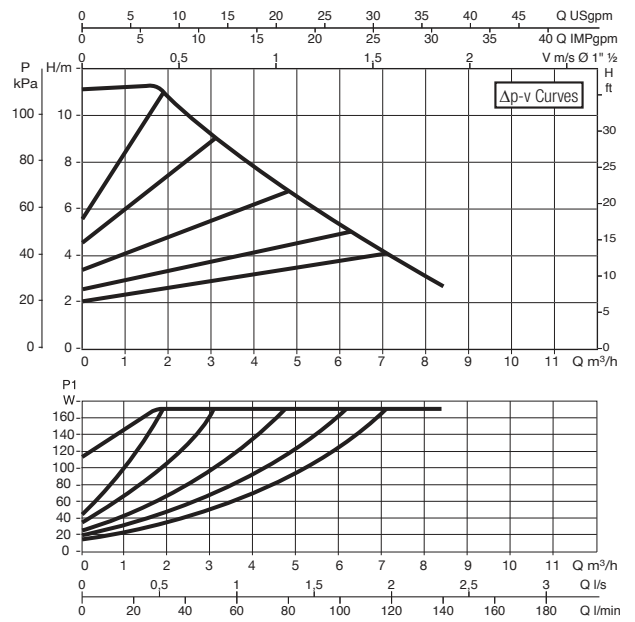

The curves are based on kinematic viscosity values = 1 mm²/s and density equal to 1000 kg/m³. Curve tolerance according to ISO 9906. Fixed speed curves available on the DNA.

MODEL	CENTRE DISTANCE mm	UNIONS ON REQUEST		COUNTERFLANGES ON REQUEST	POWER INPUT 50/60 Hz	P1 MAX W	I _n A	EEI*	MINIMU SUCTION PRESSURE			WEIGHT Kg
		STANDARDIZED	SPECIAL						t°	90°	100°	
EVOPLUS 80/180 M	180	1" F	¾" F - 1¼" M	-	220/240 V	130	0,95	EEI ≤ 0,20	m.c.w.	20	25	4,5
EVOPLUS 110/180 M	180	1" F	¾" F - 1¼" M	-	220/240 V	170	1,18	EEI ≤ 0,20	m.c.w.	20	25	4,5

The parameter of reference for the more efficient circulators is EEI ≤ 0,20.

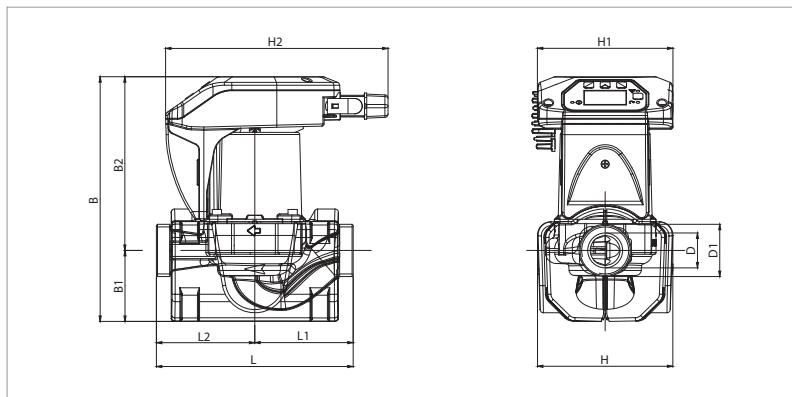

L	L1	L2	B	B1	B2
180	90	90	224	65	159

D	D1	H	H1	H2
32	1½"	124	124	204

EVOPLUS SMALL - WET ROTOR ELECTRONIC CIRCULATORS

Pumped liquid temperature range: from -10 °C to +110 °C - Maximum operating pressure: 16 bar (1600 kPa)

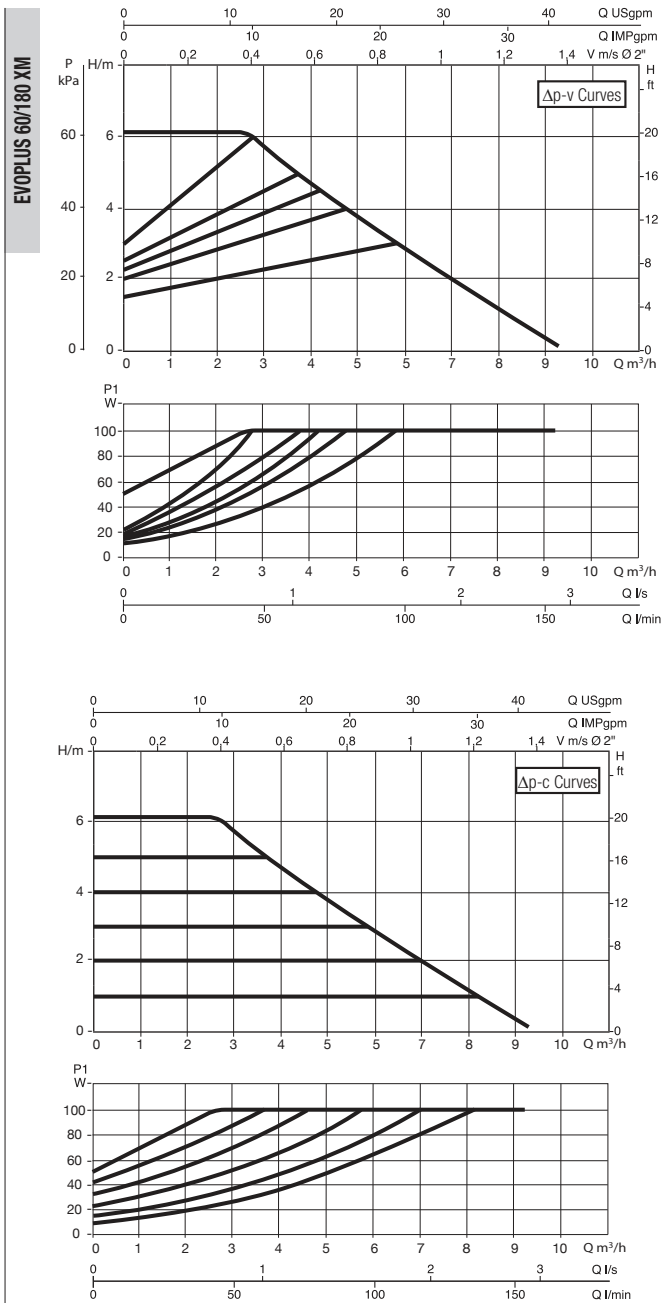
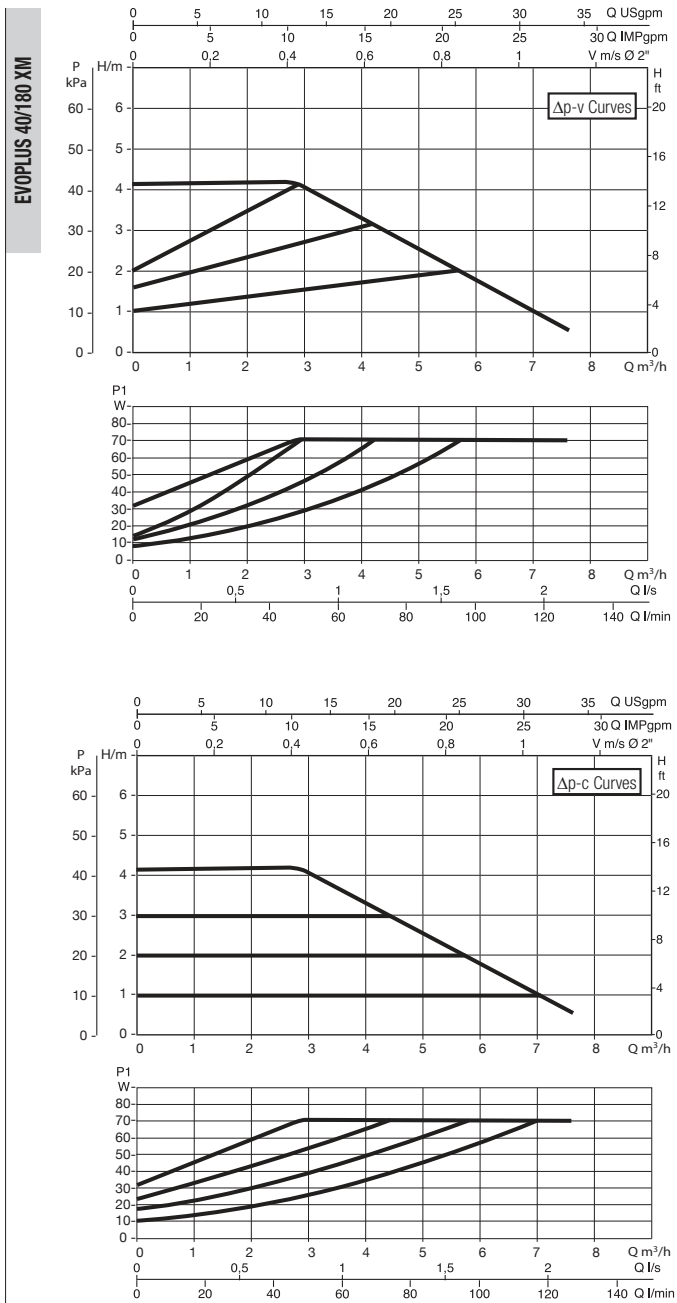

The curves are based on kinematic viscosity values = 1 mm²/s and density equal to 1000 kg/m³. Curve tolerance according to ISO 9906. Fixed speed curves available on the DNA.

MODEL	CENTRE DISTANCE mm	UNIONS ON REQUEST		COUNTERFLANGES ON REQUEST	INPUT POWER 50/60 Hz	P1 MAX W	In A	EEI*	MINIMUM SUCTION PRESSURE			WEIGHT Kg
		STANDARDISED	SPECIAL						t°	90°	100°	
EVOPLUS 40/180 XM	180	1¼" F	-	-	220/240 V	68	0,51	EEI ≤ 0,20	m.c.w.	20	25	4,7
EVOPLUS 60/180 XM	180	1¼" F	-	-	220/240 V	100	0,71	EEI ≤ 0,20	m.c.w.	20	25	4,7

The parameter of reference for the more efficient circulators is EEI ≤ 0,20.

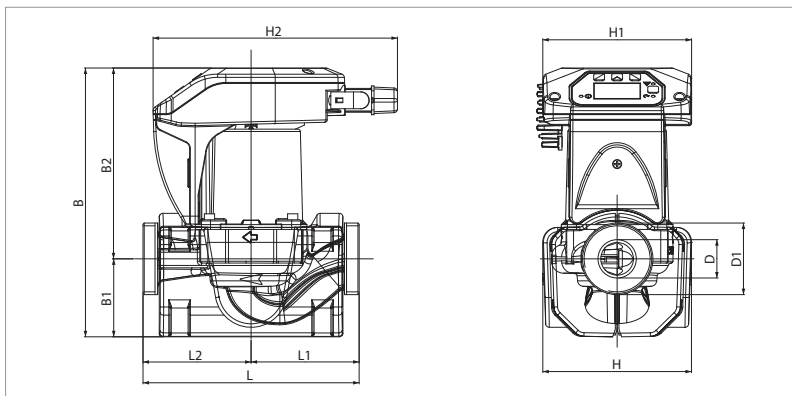

L	L1	L2	B	B1	B2
180	90	90	224	65	159

D	D1	H	H1	H2
32	2"	124	124	204

EVOPLUS SMALL - WET ROTOR ELECTRONIC CIRCULATORS

Pumped liquid temperature range: from -10 °C to +110 °C - Maximum operating pressure: 16 bar (1600 kPa)

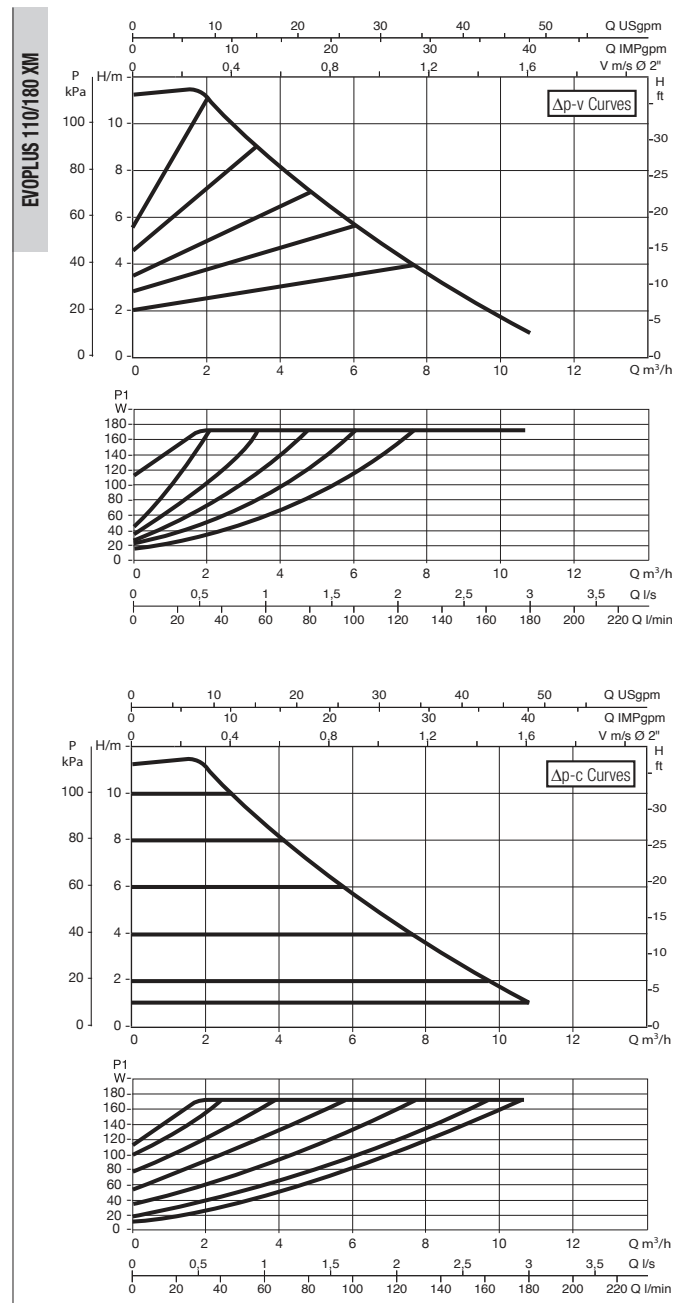
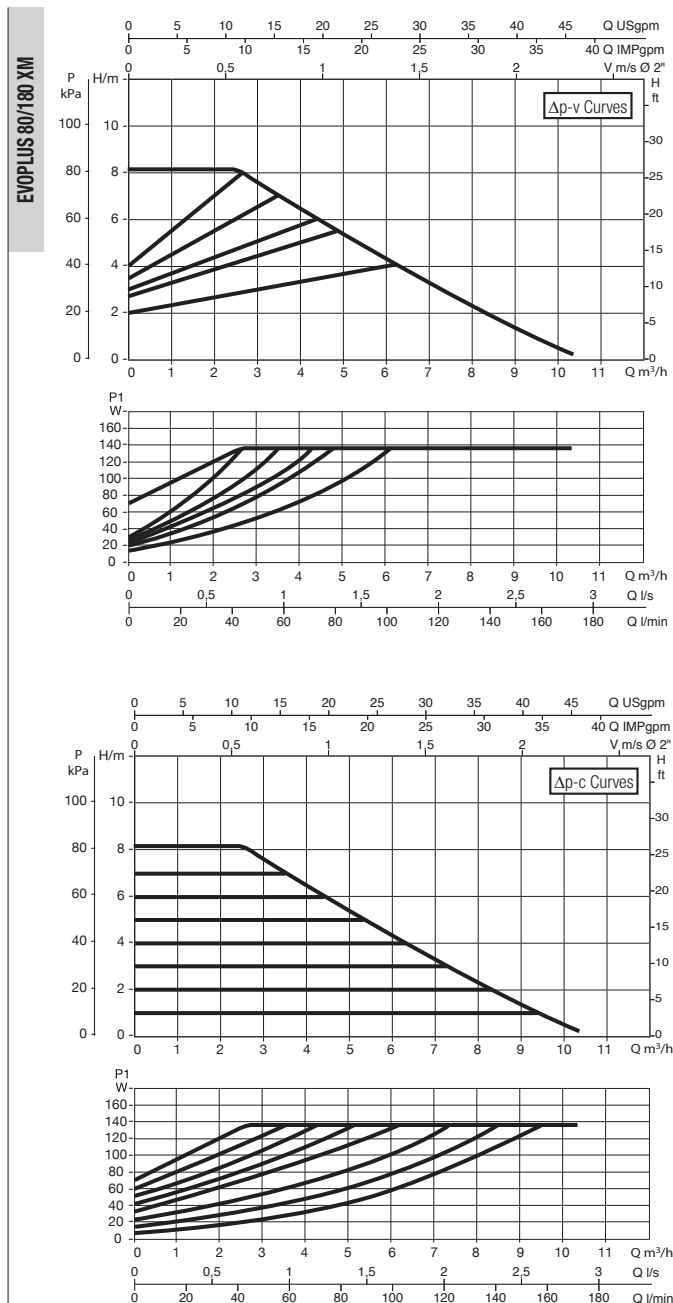

The curves are based on kinematic viscosity values = 1 mm²/s and density equal to 1000 kg/m³. Curve tolerance according to ISO 9906. Fixed speed curves available on the DNA.

MODEL	CENTRE DISTANCE mm	UNIONS ON REQUEST		COUNTERFLANGES ON REQUEST	POWER INPUT 50/60 Hz	P1 MAX W	In A	EEI*	MINIMUM SUCTION PRESSURE			WEIGHT Kg
		STANDARDISED	SPECIAL						t°	90°	100°	
EVOPLUS 80/180 XM	180	1¼" F	-	-	220/240 V	130	0,93	EEI ≤ 0,20	m.c.w.	20	25	4,7
EVOPLUS 110/180 XM	180	1¼" F	-	-	220/240 V	170	1,18	EEI ≤ 0,20	m.c.w.	20	25	4,7

The parameter of reference for the more efficient circulators is EEI ≤ 0,20.

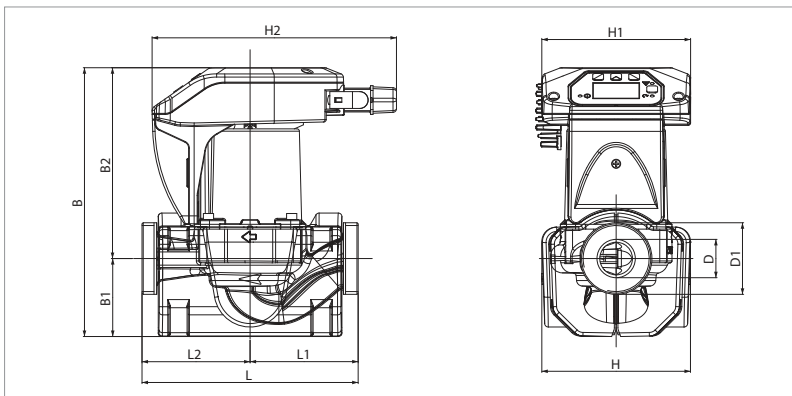

L	L1	L2	B	B1	B2
180	90	90	224	65	159

D	D1	H	H1	H2
32	2"	124	124	204

EVOPLUS SMALL - WET ROTOR ELECTRONIC CIRCULATORS

Pumped liquid temperature range: from -10 °C to +110 °C - Maximum operating pressure: 16 bar (1600 kPa)

EVOPLUS B 40/220.32 M

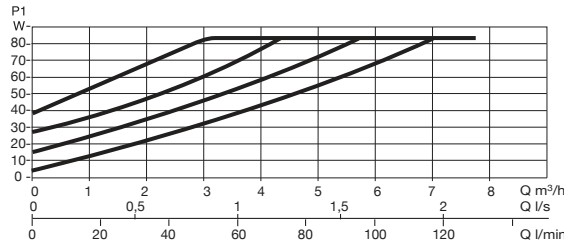
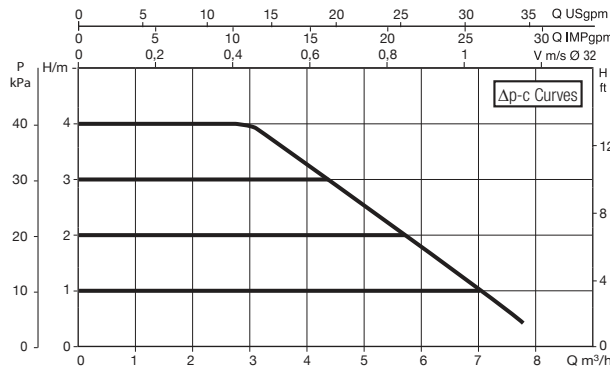
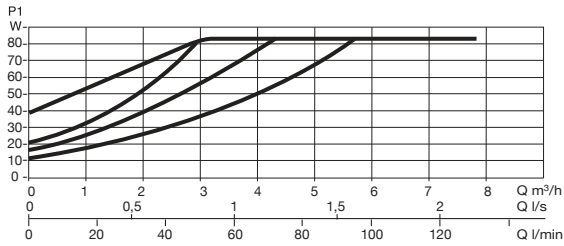
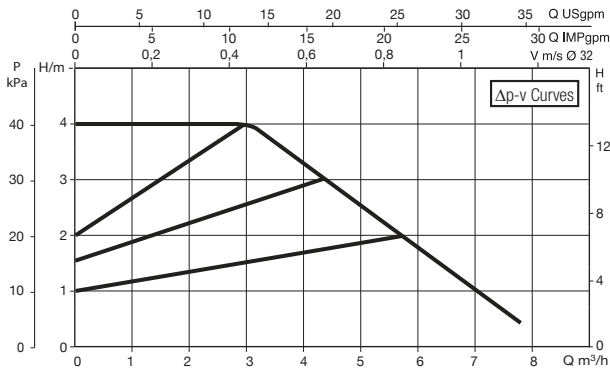

EVOPLUS B 60/220.32 M

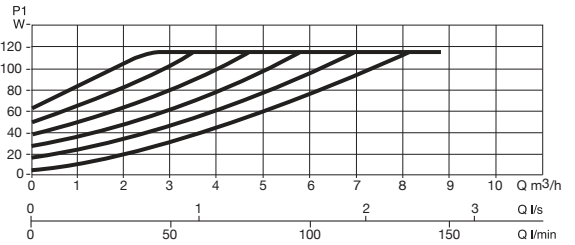
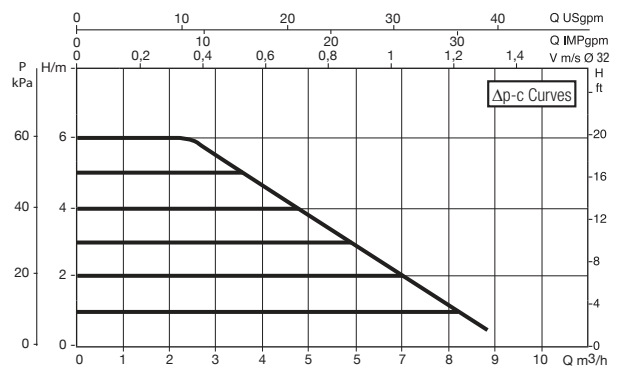
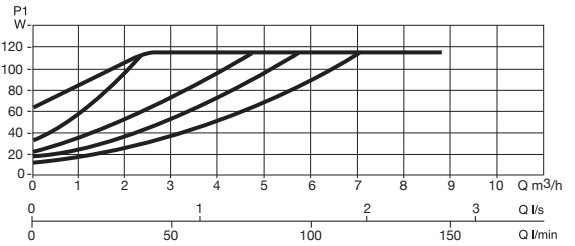
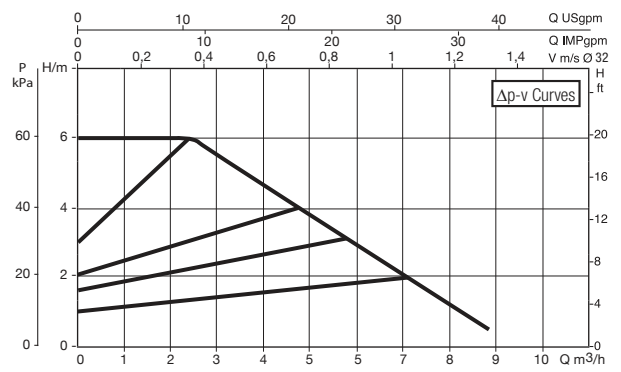

The curves are based on kinematic viscosity values = 1 mm²/s and density equal to 1000 kg/m³. Curve tolerance according to ISO 9906. Fixed speed curves available on the DNA.

MODEL	DISTANCE CENTRE mm	UNIONS ON REQUEST		COUNTERFLANGES ON REQUEST	POWER INPUT 50/60 Hz	P1 MAX W	In A	EEI*	MINIMUM SUCTION PRESSURE			WEIGHT Kg
		STANDARDISED	SPECIAL						t°	90°	100°	
EVOPLUS B 40/220.32 M	220	-	-	DN32 PN 6	220/240 V	68	0,55	EEI ≤ 0,20	m.c.w.	20	25	7,5
EVOPLUS B 60/220.32 M	220	-	-	DN32 PN 6	220/240 V	100	0,75	EEI ≤ 0,20	m.c.w.	20	25	7,5

The parameter of reference for the more efficient circulators is EEI ≤ 0,20.

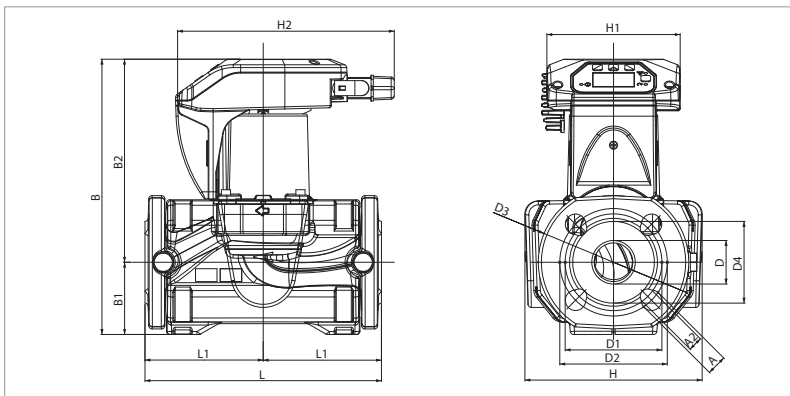

L	L1	L2	A	A2	B	B1	B2
220	110	110	19	14	256	67	189

D	D1	D2	D3	D4	H	H1	H2
40	90	100	140	76	165	124	204

EVOPLUS SMALL - WET ROTOR ELECTRONIC CIRCULATORS

Pumped liquid temperature range: from -10 °C to +110 °C - Maximum operating pressure: 16 bar (1600 kPa)

EVOPLUS B 80/220.32 M

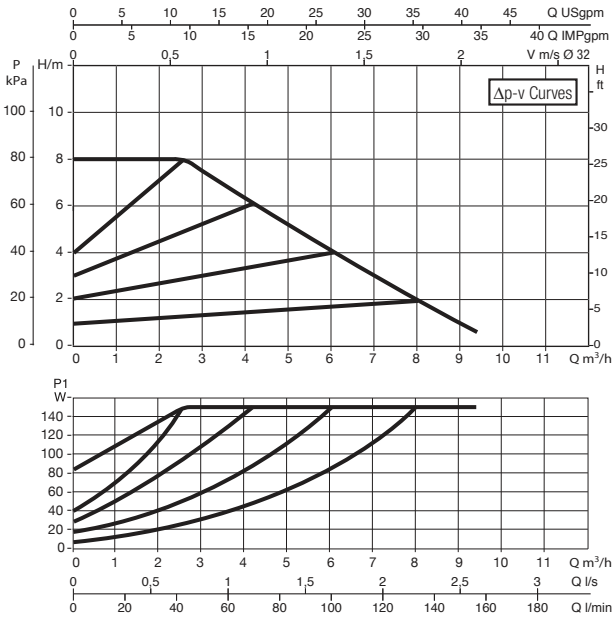

EVOPLUS B 110/220.32 M

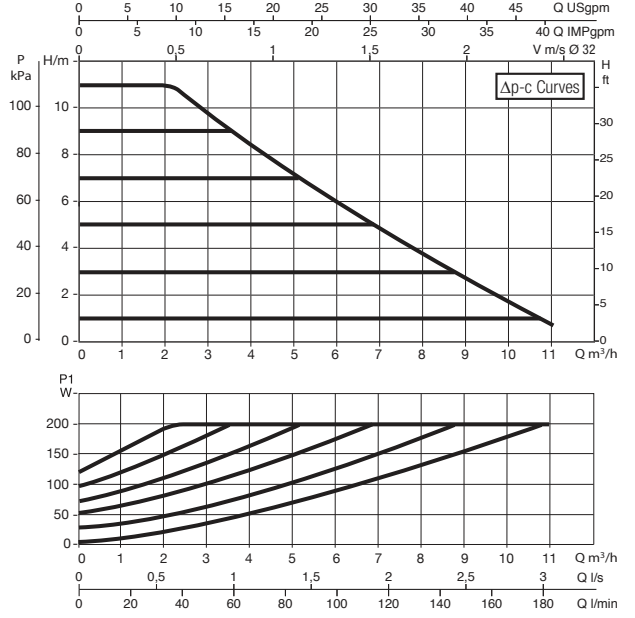
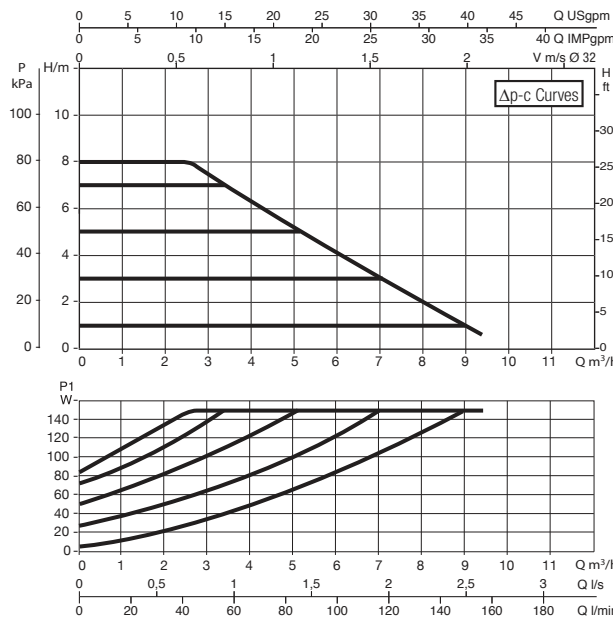
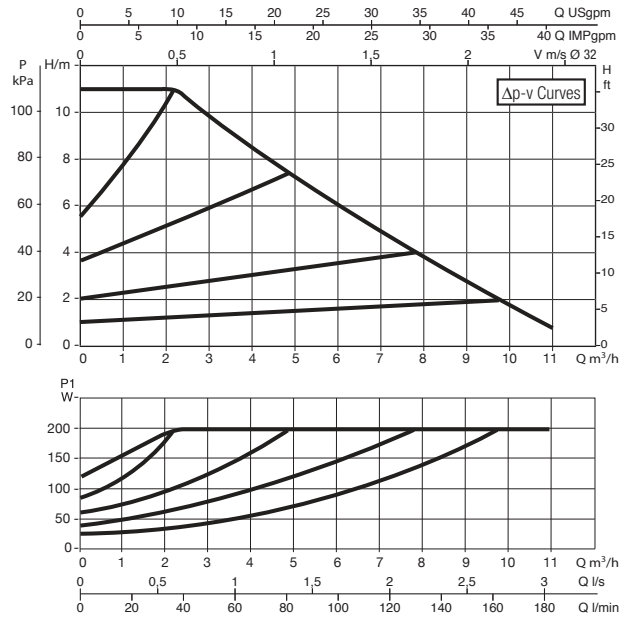

The curves are based on kinematic viscosity values = 1 mm²/s and density equal to 1000 kg/m³. Curve tolerance according to ISO 9906. Fixed speed curves available on the DNA.

MODEL	CENTRE DISTANCE mm	UNIONS ON REQUEST		COUNTERFLANGES ON REQUEST	POWER INPUT 50/60 Hz	P1 MAX W	In A	EEI *	MINIMUM SUCTION PRESSURE			WEIGHT Kg
		STANDARDISED	SPECIAL						t°	90°	100°	
EVOPLUS B 80/220.32 M	220	-	-	DN32 PN 6	220/240 V	132	0,97	EEI ≤ 0,20	m.c.w.	20	25	7,5
EVOPLUS B 110/220.32 M	220	-	-	DN32 PN 6	220/240 V	180	1,3	EEI ≤ 0,20	m.c.w.	20	25	7,5

The parameter of reference for the more efficient circulators is EEI ≤ 0,20.

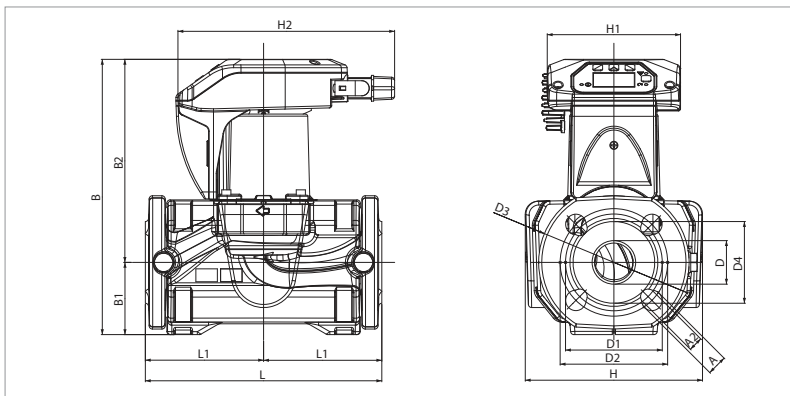

L	L1	L2	A	A2	B	B1	B2
220	110	110	19	14	256	67	189

D	D1	D2	D3	D4	H	H1	H2
40	90	100	140	76	165	124	204

EVOPLUS SMALL - WET ROTOR ELECTRONIC CIRCULATORS

Pumped liquid temperature range: from -10 °C to +110 °C - Maximum operating pressure: 16 bar (1600 kPa)

EVOPLUS B 40/250.40 M

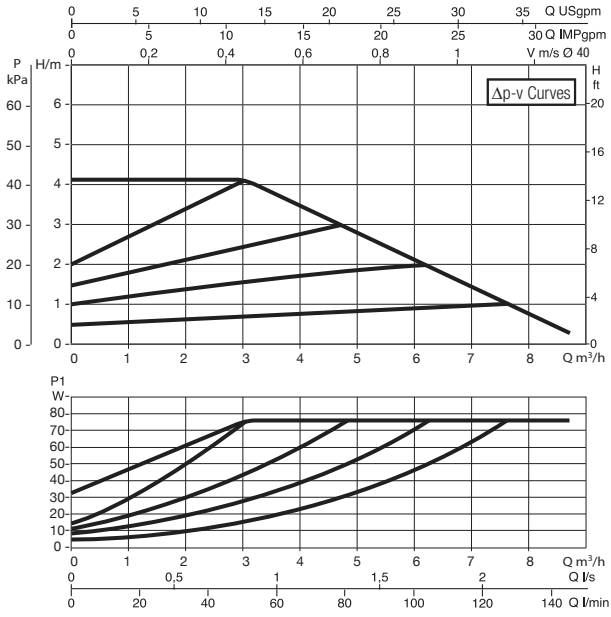

EVOPLUS B 60/250.40 M

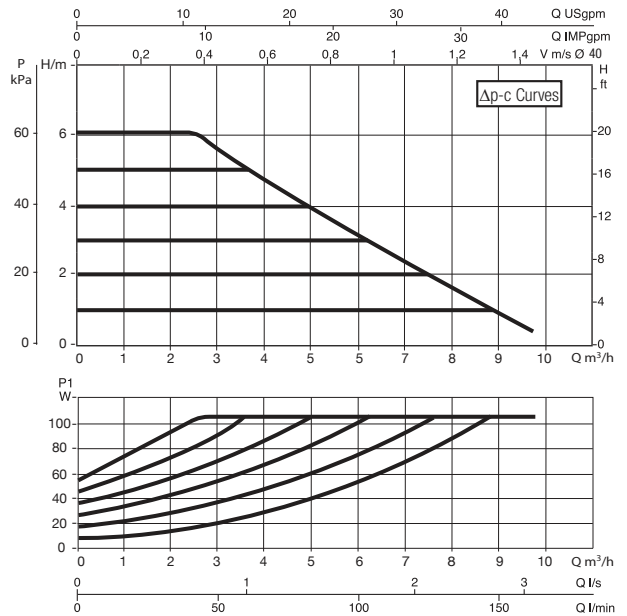
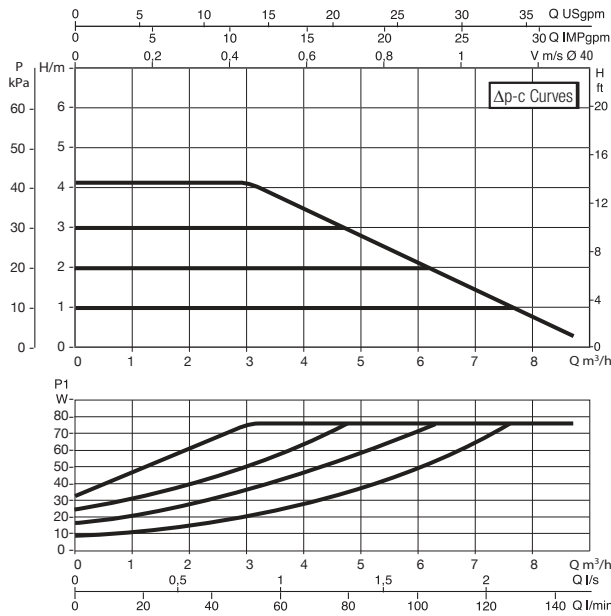
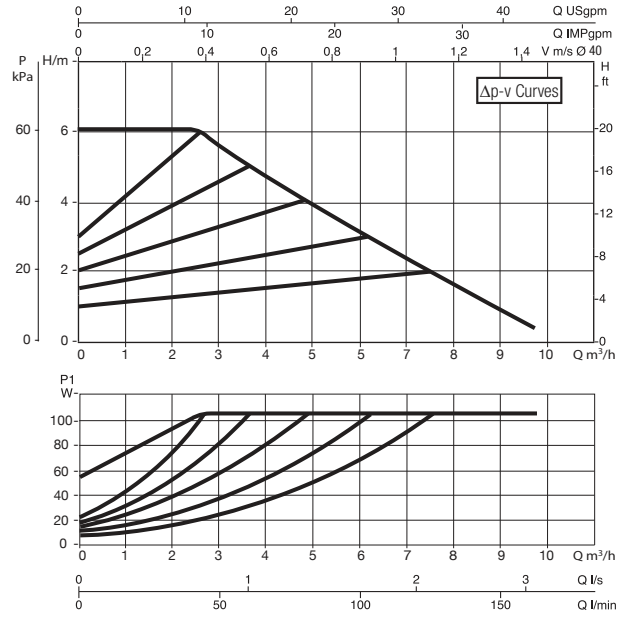

The curves are based on kinematic viscosity values = 1 mm²/s and density equal to 1000 kg/m³. Curve tolerance according to ISO 9906. Fixed speed curves available on the DNA.

MODEL	CENTRE DISTANCE mm	UNIONS ON REQUEST		COUNTERFLANGES ON REQUEST	POWER INPUT 50/60 Hz	P1 MAX W	In A	EEI*	MINIMUM SUCTION PRESSURE			WEIGHT Kg
		STANDARDISED	SPECIAL						t°	90°	100°	
EVOPLUS B 40/250.40 M	250	-	-	DN40 PN 10	220/240 V	70	0,55	EEI ≤ 0,20	m.c.w.	20	25	7,5
EVOPLUS B 60/250.40 M	250	-	-	DN40 PN 10	220/240 V	100	0,75	EEI ≤ 0,20	m.c.w.	20	25	7,5

The parameter of reference for the more efficient circulators is EEI ≤ 0,20.

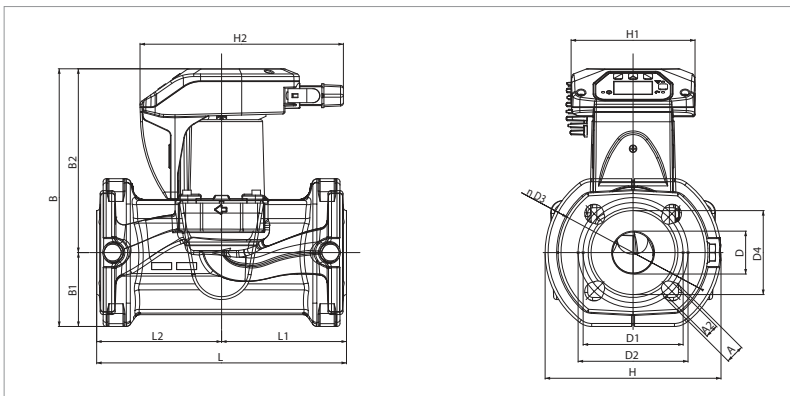

L	L1	L2	A	A2	B	B1	B2
250	125	125	19	14	258	74	184

D	D1	D2	D3	D4	H	H1	H2
43	100	110	150	84	176	124	204



EVOPLUS SMALL - WET ROTOR ELECTRONIC CIRCULATORS

Pumped liquid temperature range: from -10 °C to +110 °C - Maximum operating pressure: 16 bar (1600 kPa)

EVOPLUS B 80/250.40 M

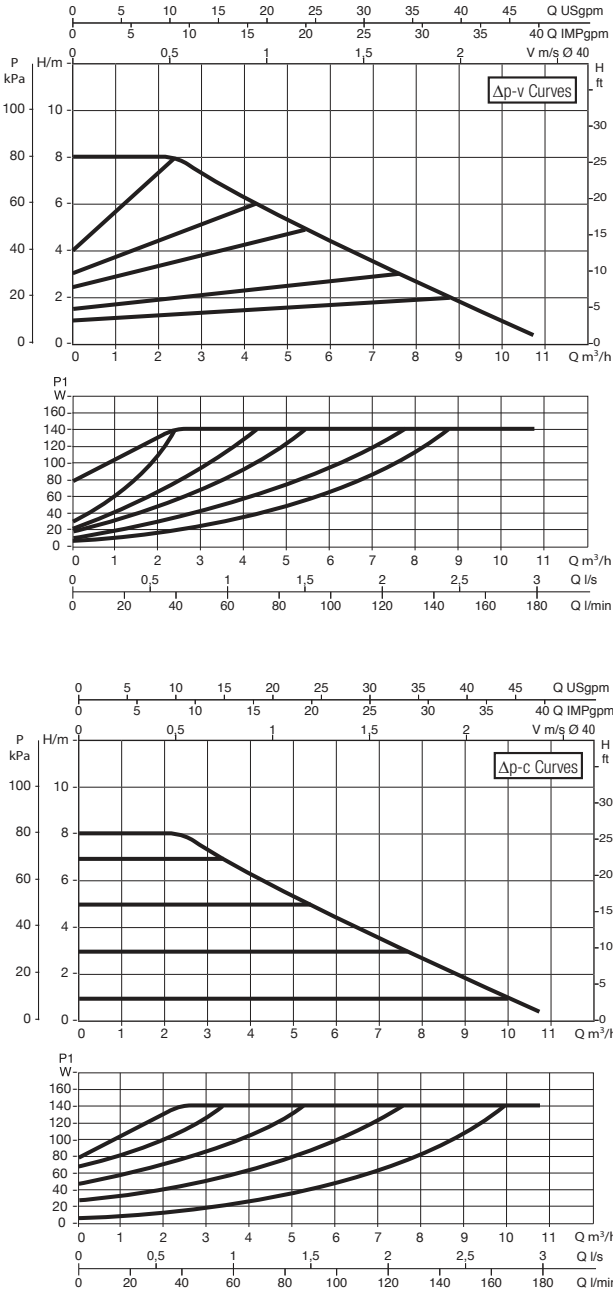

EVOPLUS B 110/250.40 M

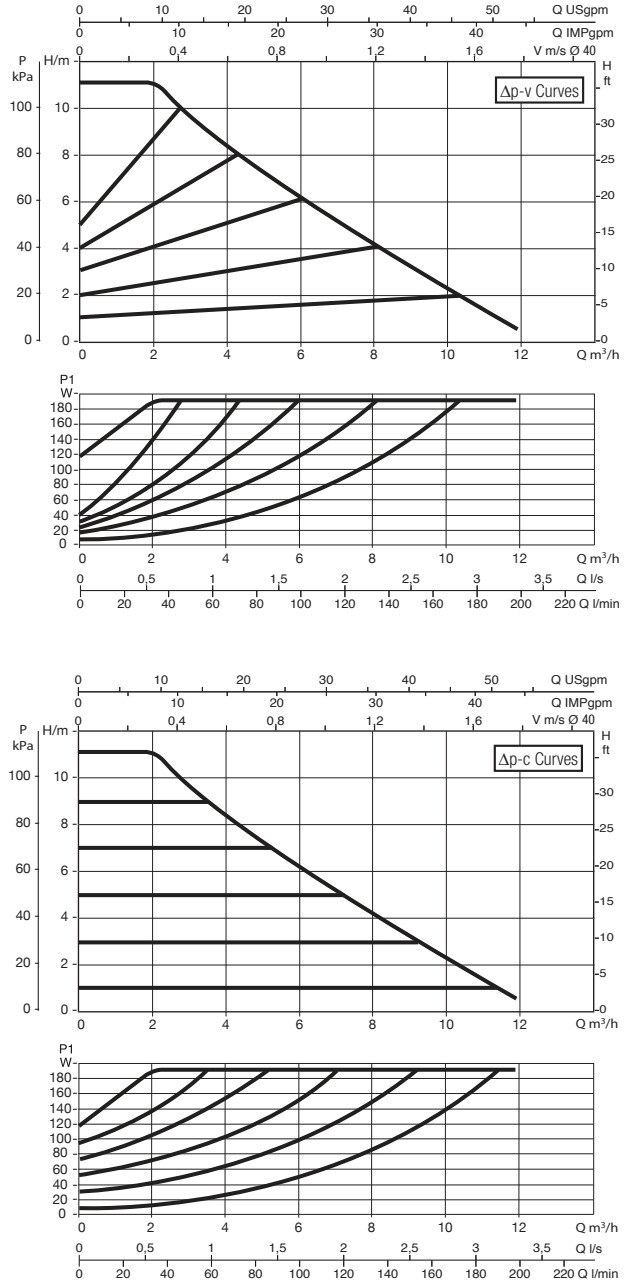

The curves are based on kinematic viscosity values = 1 mm²/s and density equal to 1000 kg/m³. Curve tolerance according to ISO 9906. Fixed speed curves available on the DNA.

MODEL	CENTRE DISTANCE mm	UNIONS ON REQUEST		COUNTERFLANGES ON REQUEST	POWER INPUT 50/60 Hz	P1 MAX W	In A	EEI*	MINIMUM SUCTION PRESSURE			WEIGHT Kg
		STANDARDISED	SPECIAL						t°	90°	100°	
EVOPLUS B 80/250.40 M	250	-	-	DN40 PN 10	220/240 V	132	0,97	EEI ≤ 0,20	m.c.w.	20	25	7,5
EVOPLUS B 110/250.40 M	250	-	-	DN40 PN 10	220/240 V	180	1,3	EEI ≤ 0,20	m.c.w.	20	25	7,5

The parameter of reference for the more efficient circulators is EEI ≤ 0,20.

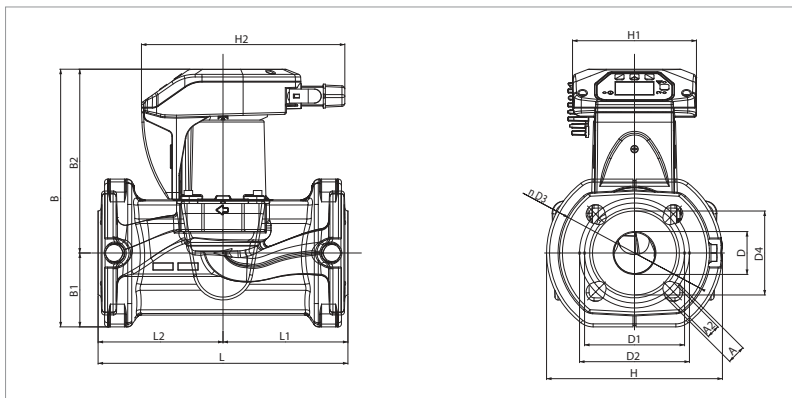

L	L1	L2	A	A2	B	B1	B2
250	125	125	19	14	258	74	184

D	D1	D2	D3	D4	H	H1	H2
43	100	110	150	84	176	124	204

EVOPLUS SMALL - WET ROTOR ELECTRONIC CIRCULATORS

Pumped liquid temperature range: from -10 °C to +110 °C - Maximum operating pressure: 16 bar (1600 kPa)

EVOPLUS D 40/220.32 M

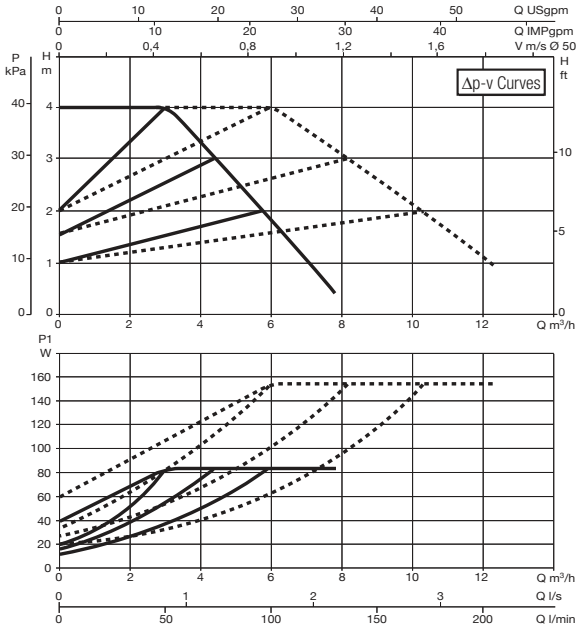

EVOPLUS D 60/220.32 M

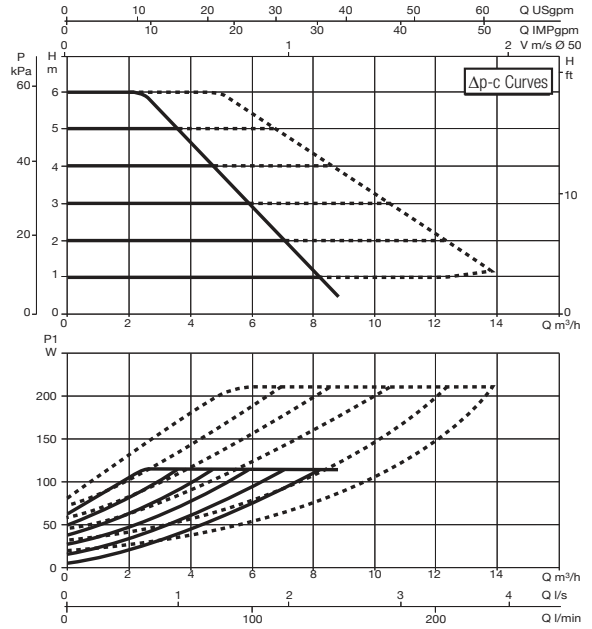
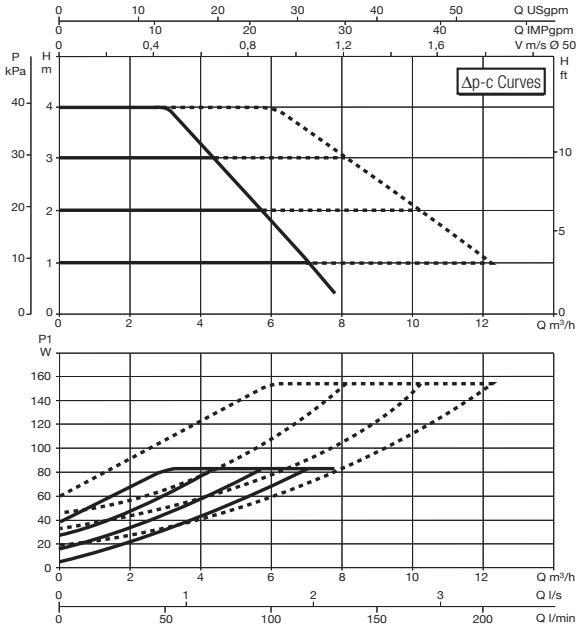
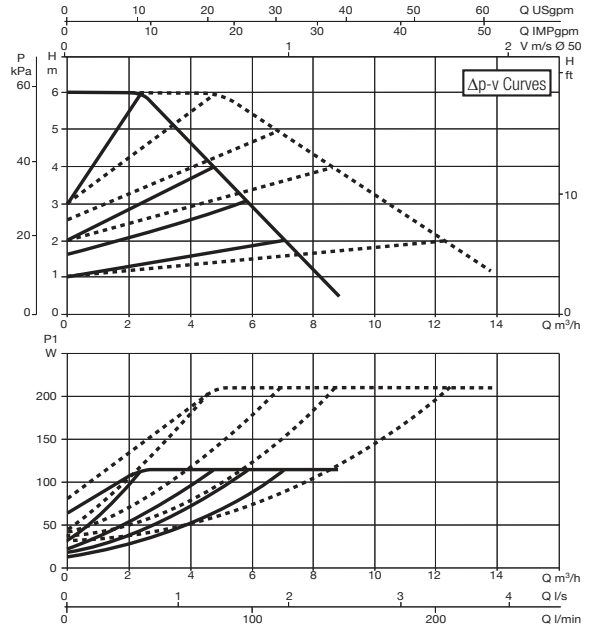

The curves are based on kinematic viscosity values = 1 mm²/s and density equal to 1000 kg/m³. Curve tolerance according to ISO 9906. Fixed speed curves available on the DNA.

MODEL	CENTRE DISTANCE mm	UNIONS ON REQUEST		COUNTERFLANGES ON REQUEST	POWER INPUT 50/60 Hz	P1 MAX W	In A	EEI*	MINIMUM SUCTION PRESSURE			WEIGHT Kg
		STANDARDISED	SPECIAL						t°	90°	100°	
EVOPLUS D 40/220.32 M	220	-	-	DN32 PN 6	220/240 V	70	0,55	EEI ≤ 0,20	m.c.w.	20	25	13,5
EVOPLUS D 60/220.32 M	220	-	-	DN32 PN 6	220/240 V	95	0,75	EEI ≤ 0,20	m.c.w.	20	25	13,5

The parameter of reference for the more efficient circulators is EEI ≤ 0,20.

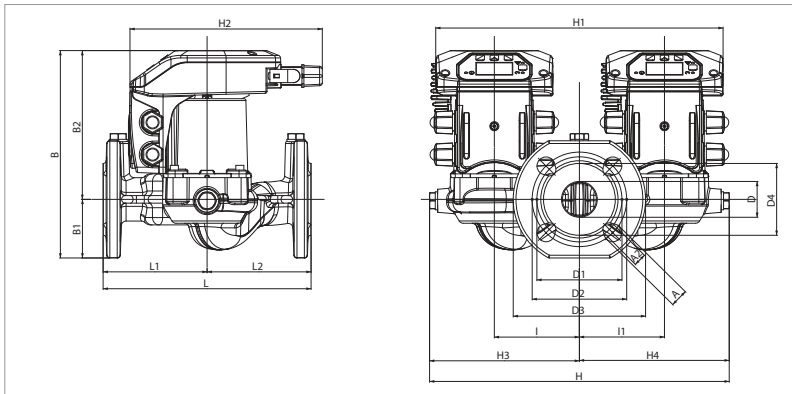

L	L1	L2	A	A2	B	B1	B2	D	D1
220	110	110	19	14	220	62	158	40	90

D2	D3	D4	I	I1	H	H1	H2	H3	H4
100	140	76	90	90	300	304	204	150	150

EVOPLUS SMALL - WET ROTOR ELECTRONIC CIRCULATORS

Pumped liquid temperature range: from -10 °C to +110 °C - Maximum operating pressure: 16 bar (1600 kPa)

EVOPLUS D 80/220.32 M

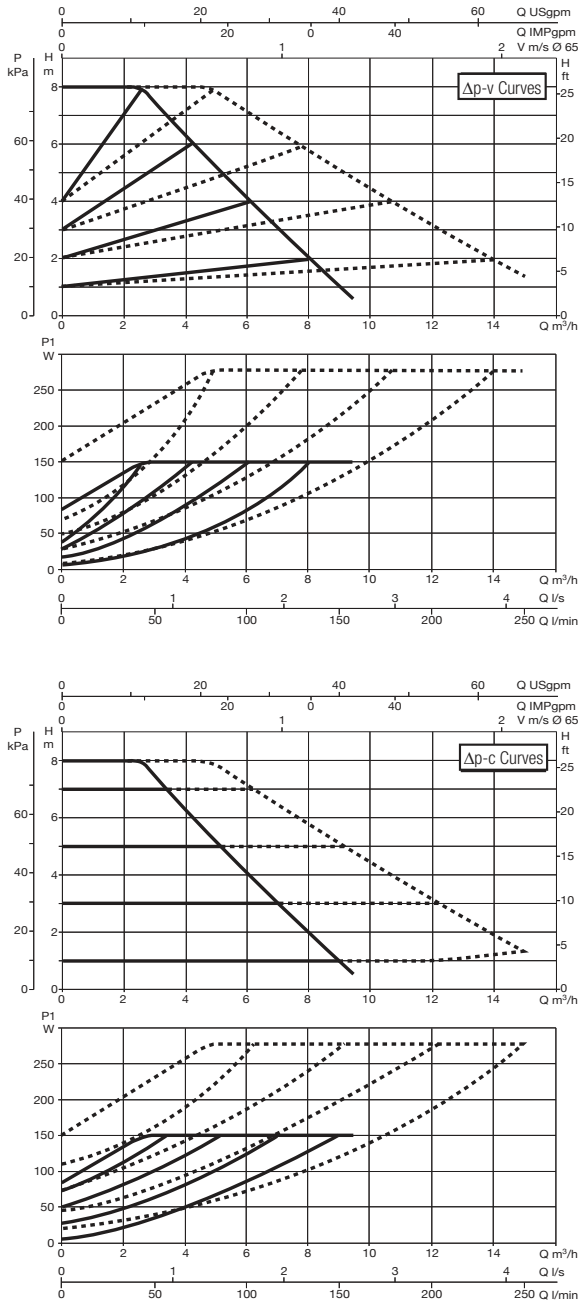

EVOPLUS D 110/220.32 M

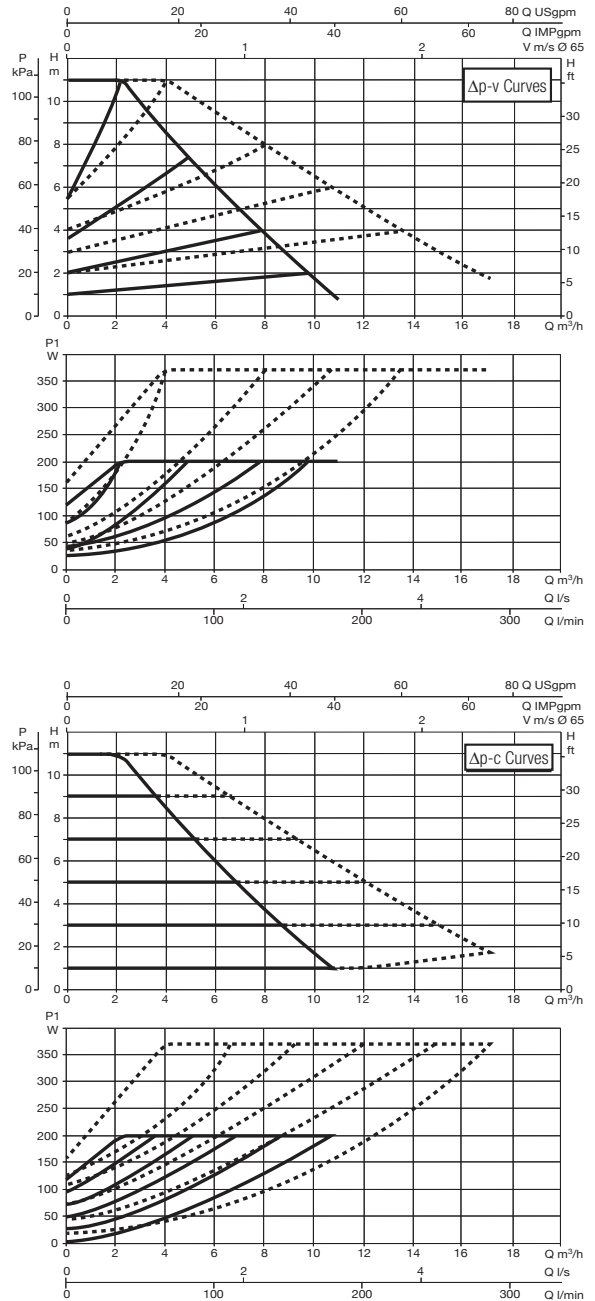

The curves are based on kinematic viscosity values = 1 mm²/s and density equal to 1000 kg/m³. Curve tolerance according to ISO 9906. Fixed speed curves available on the DNA.

MODEL	CENTRE DISTANCE mm	UNIONS ON REQUEST		COUNTERFLANGES ON REQUEST	POWER INPUT 50/60 Hz	P1 MAX W	In A	EEI *	MINIMUM SUCTION PRESSURE			WEIGHT Kg
		STANDARDISED	SPECIAL						t°	90°	100°	
EVOPLUS D 80/220.32 M	220	-	-	DN32 PN 6	220/240 V	130	0,95	EEI ≤ 0,20	m.c.w.	20	25	13,5
EVOPLUS D 110/220.32 M	220	-	-	DN32 PN 6	220/240 V	190	1,3	EEI ≤ 0,20	m.c.w.	20	25	13,5

The parameter of reference for the more efficient circulators is EEI ≤ 0,20.

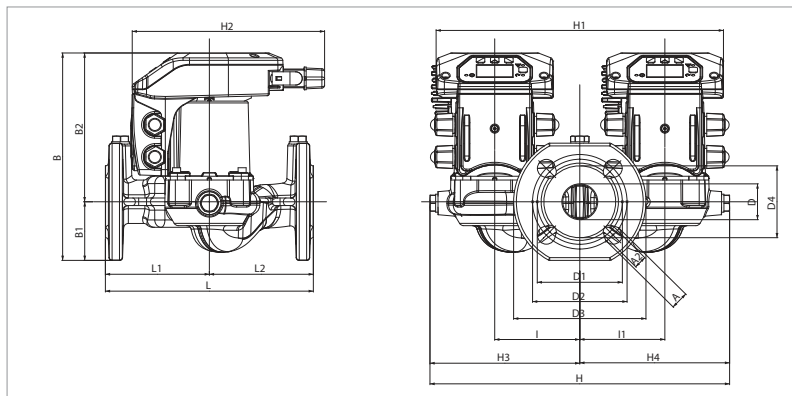

L	L1	L2	A	A2	B	B1	B2	D	D1
220	110	110	19	14	220	62	158	40	90

D2	D3	D4	I	I1	H	H1	H2	H3	H4
100	140	76	90	90	300	304	204	150	150

EVOPLUS SMALL - WET ROTOR ELECTRONIC CIRCULATORS

Pumped liquid temperature range: from -10 °C to +110 °C - Maximum operating pressure: 16 bar (1600 kPa)

EVOPLUS D 40/250.40 M

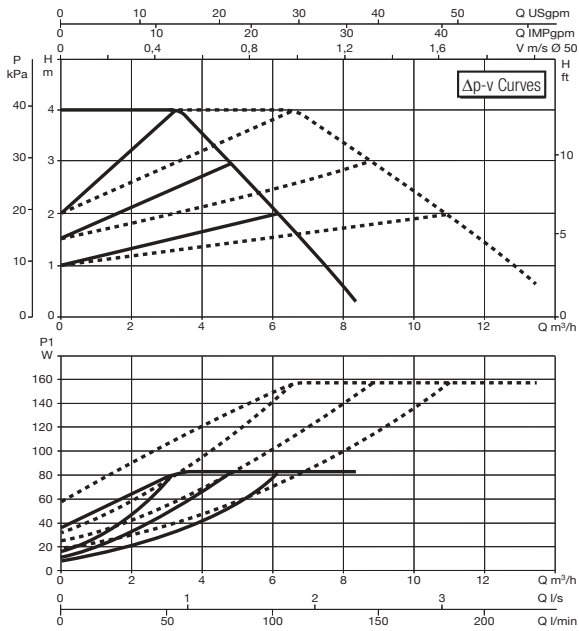

EVOPLUS D 60/250.40 M

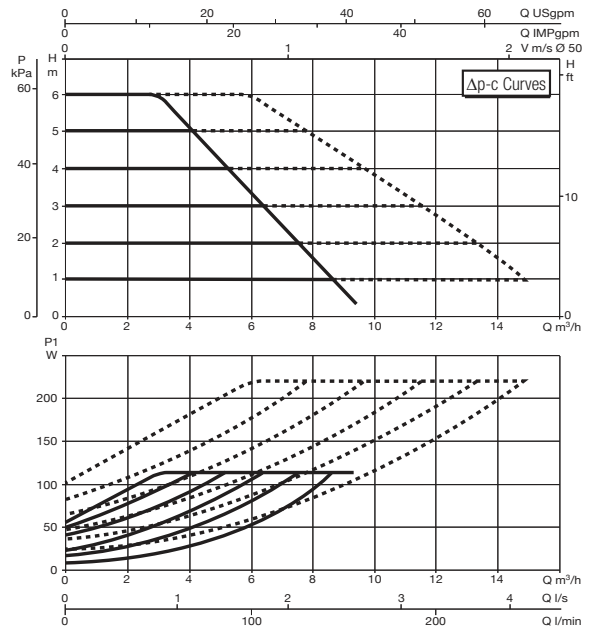
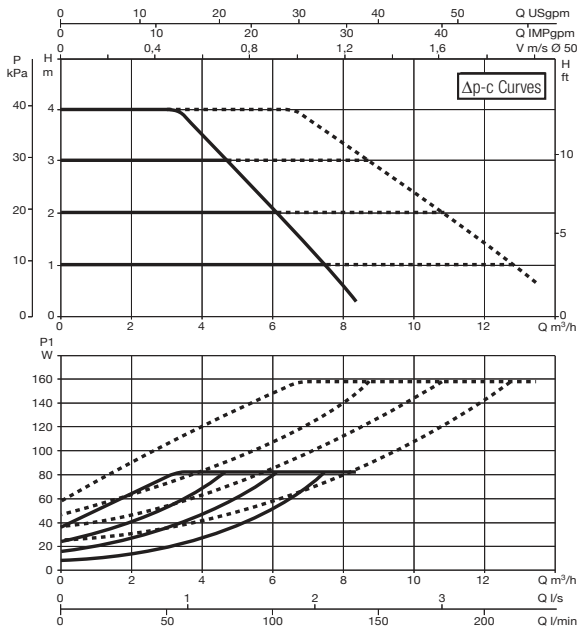
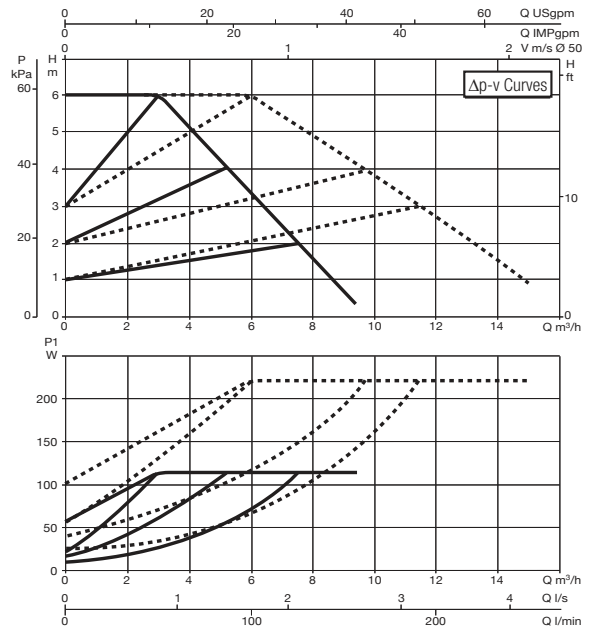

The curves are based on kinematic viscosity values = 1 mm²/s and density equal to 1000 kg/m³. Curve tolerance according to ISO 9906. Fixed speed curves available on the DNA.

MODEL	CENTRE DISTANCE mm	UNIONS ON REQUEST		COUNTERFLANGES ON REQUEST	POWER INPUT 50/60 Hz	P1 MAX W	I _n A	EEI*	MINIMUM SUCTION PRESSURE			WEIGHT Kg
		STANDARDISED	SPECIAL						t°	90°	100°	
EVOPLUS D 40/250.40 M	250	-	-	DN40 PN 10	220/240 V	75	0,55	EEI ≤ 0,20	m.c.w.	20	25	14,2
EVOPLUS D 60/250.40 M	250	-	-	DN40 PN 10	220/240 V	100	0,75	EEI ≤ 0,20	m.c.w.	20	25	14,2

The parameter of reference for the more efficient circulators is EEI ≤ 0,20.

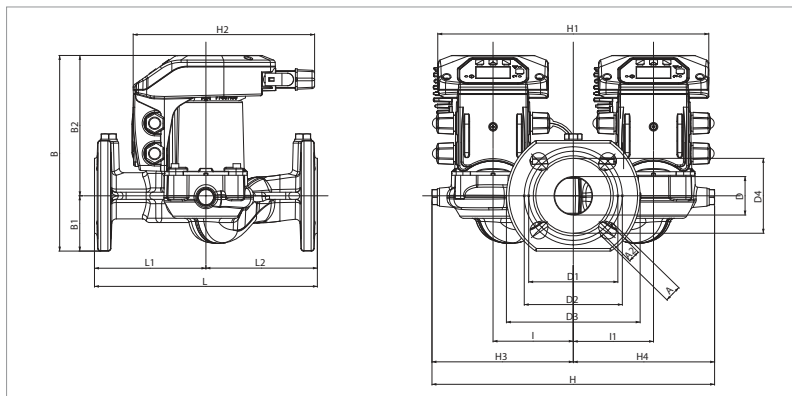

L	L1	L2	A	A2	B	B1	B2	D	D1
250	125	125	19	14	220	62	158	43	100

D2	D3	D4	I	I1	H	H1	H2	H3	H4
110	150	84	90	90	300	304	204	150	150

EVOPLUS SMALL - WET ROTOR ELECTRONIC CIRCULATORS

Pumped liquid temperature range: from -10 °C to +110 °C - Maximum operating pressure: 16 bar (1600 kPa)

EVOPLUS D 80/250.40 M

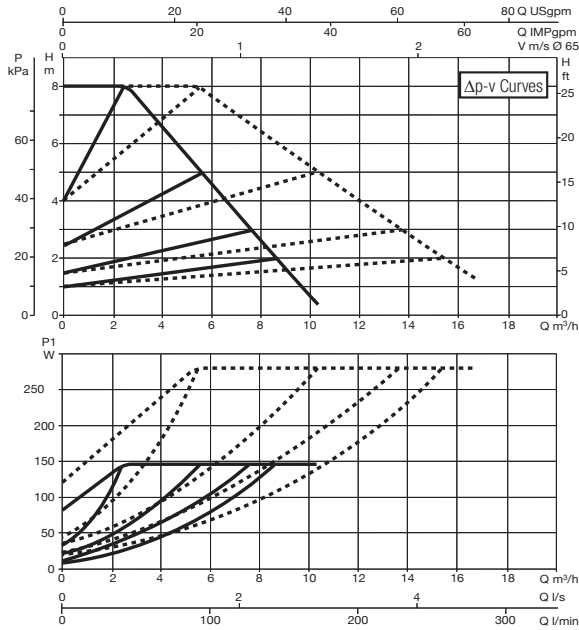

EVOPLUS D 110/250.40 M

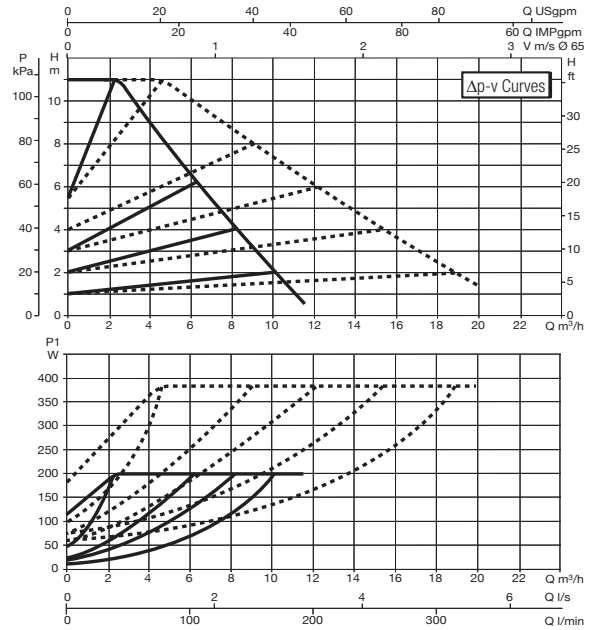

The curves are based on kinematic viscosity values = 1 mm²/s and density equal to 1000 kg/m³. Curve tolerance according to ISO 9906. Fixed speed curves available on the DNA.

MODEL	CENTRE DISTANCE mm	UNIONS ON REQUEST		COUNTERFLANGES ON REQUEST	POWER INPUT 50/60 Hz	P1 MAX W	In A	EEI*	MINIMUM SUCTION PRESSURE			WEIGHT Kg
		STANDARDISED	SPECIAL						t°	90°	100°	
EVOPLUS D 80/250.40 M	250	-	-	DN40 PN 10	220/240 V	135	0,95	EEI ≤ 0,20	m.c.w.	20	25	14,2
EVOPLUS D 110/250.40 M	250	-	-	DN40 PN 10	220/240 V	190	1,3	EEI ≤ 0,20	m.c.w.	20	25	14,2

The parameter of reference for the more efficient circulators is EEI ≤ 0,20.

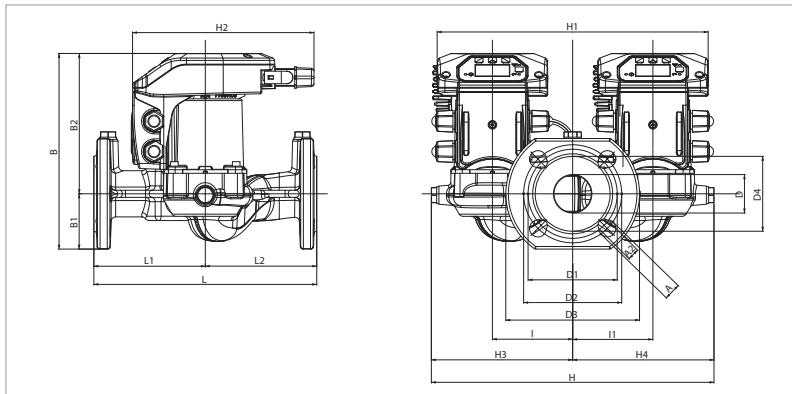

L	L1	L2	A	A2	B	B1	B2	D	D1
250	125	125	19	14	220	62	158	43	100

D2	D3	D4	I	I1	H	H1	H2	H3	H4
110	150	84	90	90	300	304	204	150	150

EVOPLUS SMALL SAN - WET ROTOR ELECTRONIC CIRCULATORS

Pumped liquid temperature range: from -10 °C to +110 °C - Maximum operating pressure: 16 bar (1600 kPa)

EVOPLUS 40/180 SAN M

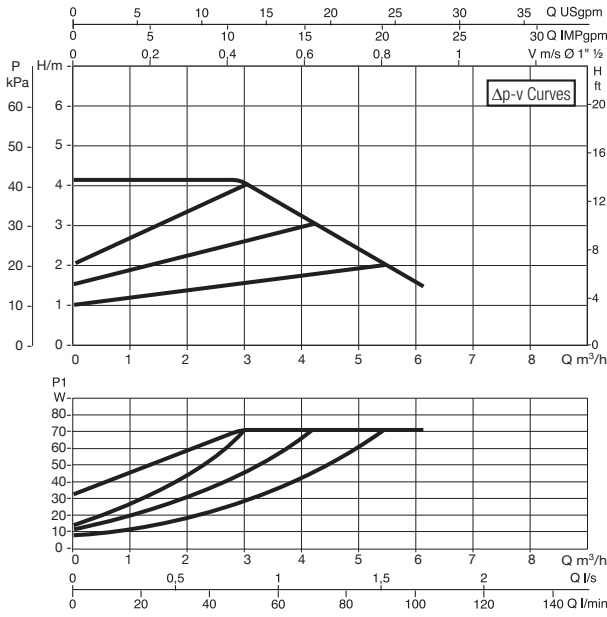

EVOPLUS 60/180 SAN M

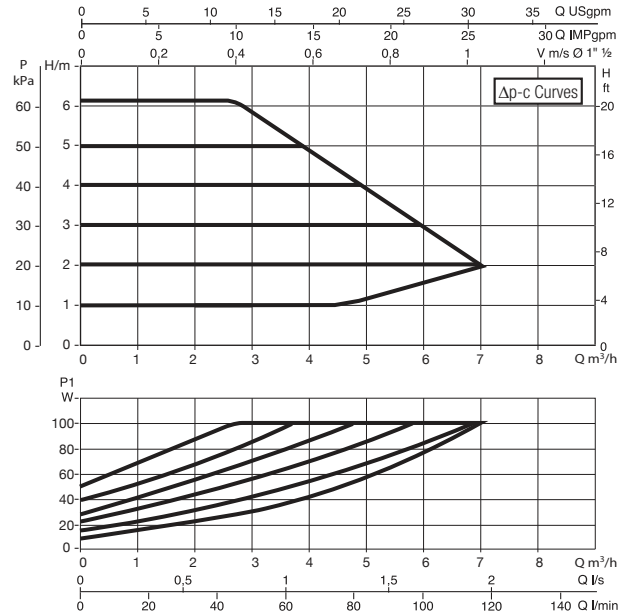
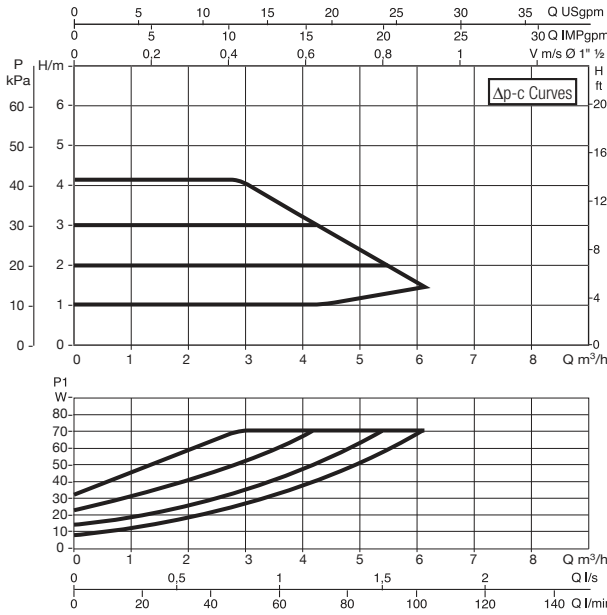
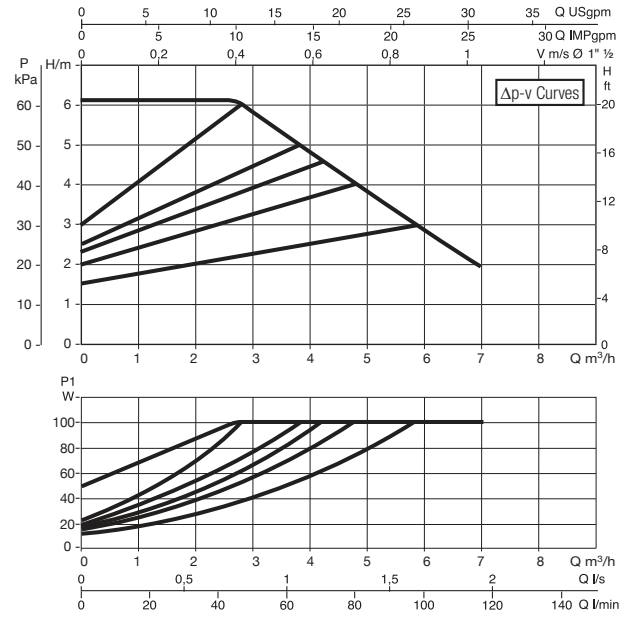

The curves are based on kinematic viscosity values = 1 mm²/s and density equal to 1000 kg/m³. Curve tolerance according to ISO 9906. Fixed speed curves available on the DNA.

MODEL	CENTRE DISTANCE mm	UNIONS ON REQUEST		COUNTERFLANGES ON REQUEST	POWER INPUT 50/60 Hz	P1 MAX W	I _n A	MINIMUM SUCTION PRESSURE			WEIGHT Kg
		STANDARDISED	SPECIAL					t°	90°	100°	
EVOPLUS 40/180 SAN M	180	1" F	1/2" F - 3/4" F	-	220/240 V	70	0,52	m.c.w.	20	25	4,5
EVOPLUS 60/180 SAN M	180	1" F	1/2" F - 3/4" F	-	220/240 V	100	0,72	m.c.w.	20	25	4,5

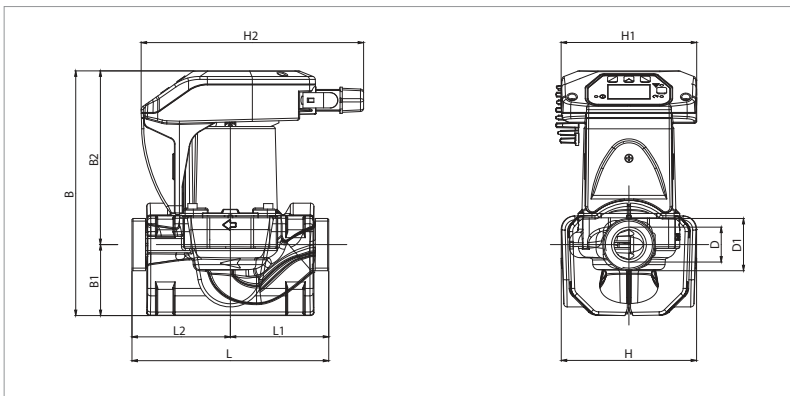

L	L1	L2	B	B1	B2	D	D1	H	H1	H2
180	90	90	224	65	159	32	1 1/2"	124	124	204



EVOPLUS SMALL SAN - WET ROTOR ELECTRONIC CIRCULATORS

Pumped liquid temperature range: from -10 °C to +110 °C - Maximum operating pressure: 16 bar (1600 kPa)

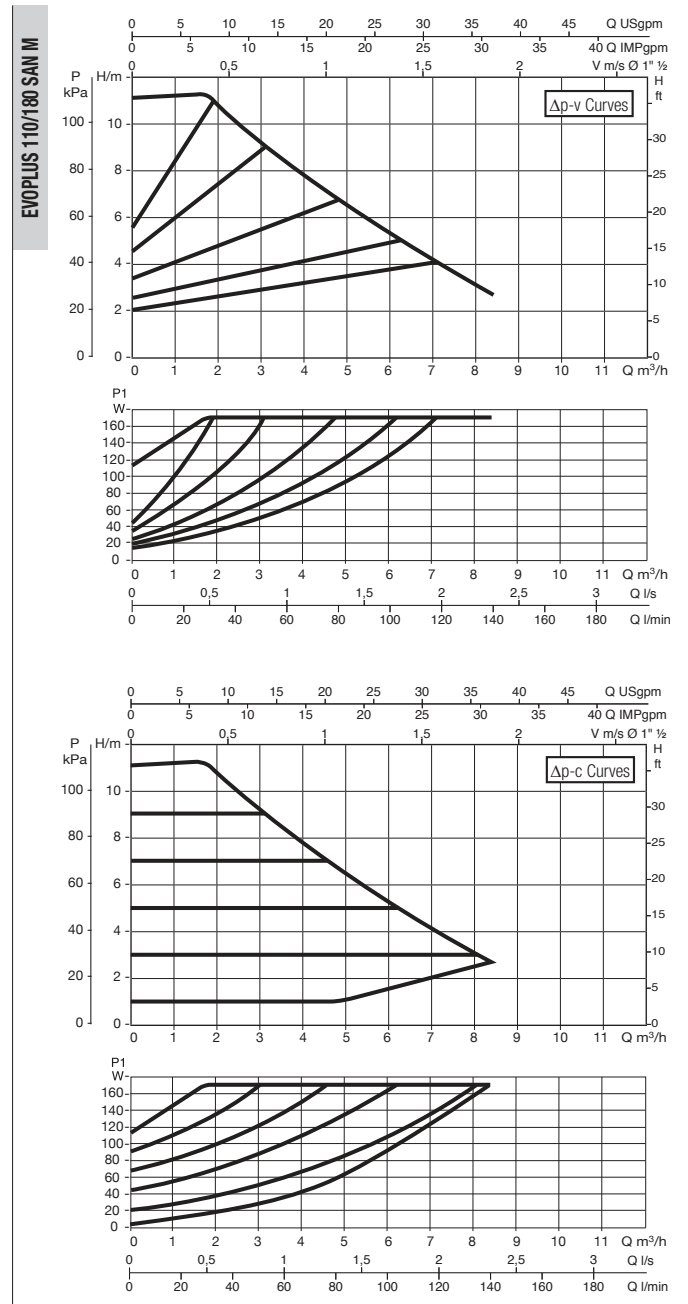
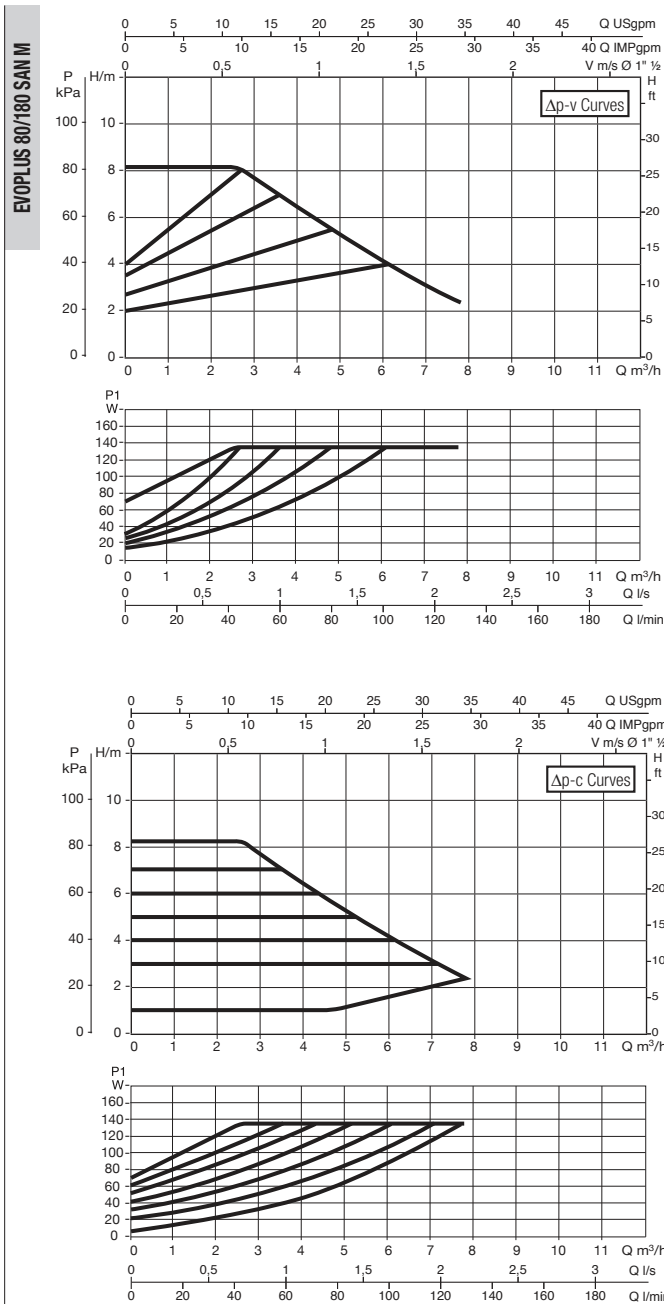

The curves are based on kinematic viscosity values = 1 mm²/s and density equal to 1000 kg/m³. Curve tolerance according to ISO 9906. Fixed speed curves available on the DNA.

MODEL	CENTRE DISTANCE mm	UNIONS ON REQUEST		COUNTERFLANGES ON REQUEST	POWER INPUT 50/60 Hz	P1 MAX W	In A	MINIMUM SUCTION PRESSURE			WEIGHT Kg
		STANDARDISED	SPECIAL					t°	90°	100°	
EVOPLUS 80/180 SAN M	180	1" F	1/2" F - 3/4" F	-	220/240 V	135	0,95	m.c.w.	20	25	4,5
EVOPLUS 110/180 SAN M	180	1" F	1/2" F - 3/4" F	-	220/240 V	170	1,16	m.c.w.	20	25	4,5

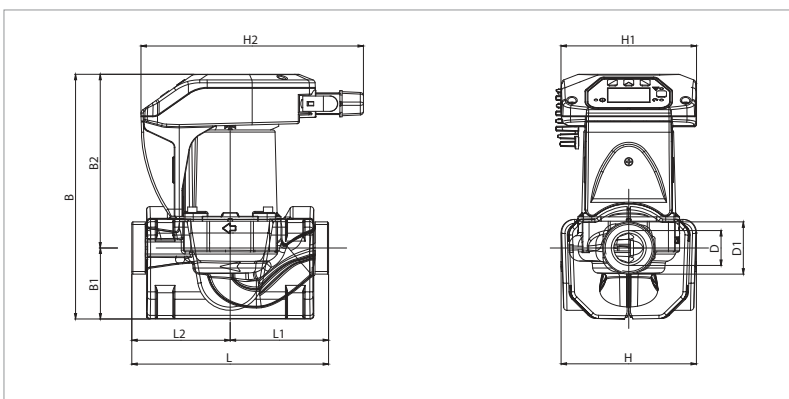

L	L1	L2	B	B1	B2	D	D1	H	H1	H2
180	90	90	224	65	159	32	1 1/2"	124	124	204

EVOPLUS SMALL SAN - WET ROTOR ELECTRONIC CIRCULATORS

Pumped liquid temperature range: from -10°C to +110 °C - Maximum operating pressure: 16 bar (1600 kPa)

EVOPLUS B 40/220.32 SAN M

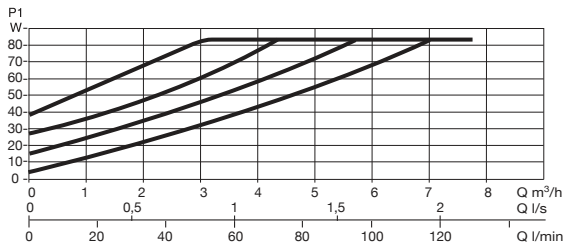
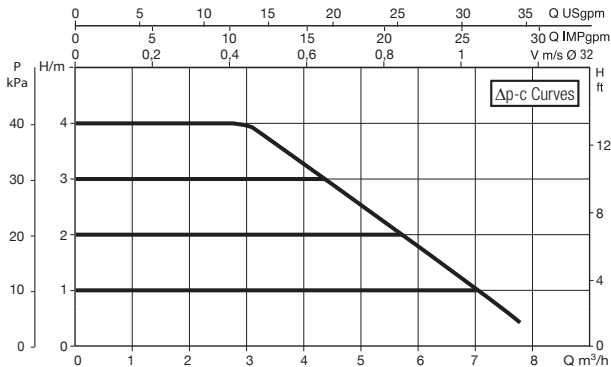
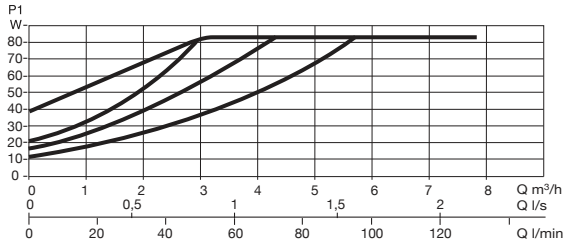
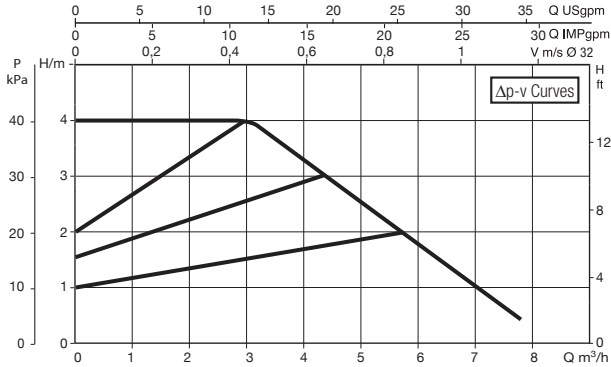

EVOPLUS B 60/220.32 SAN M

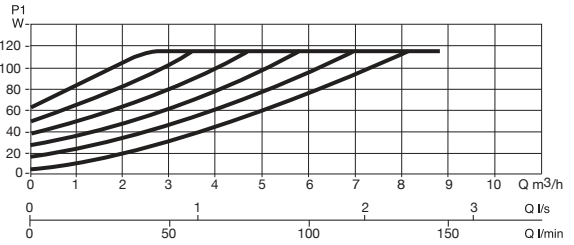
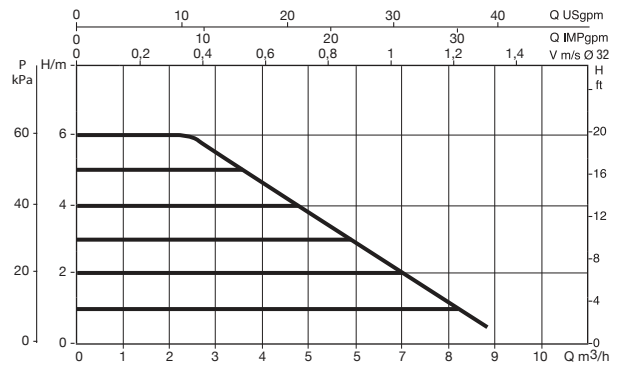
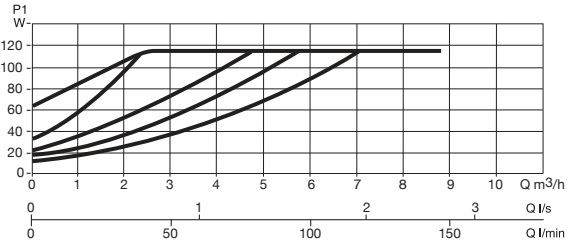
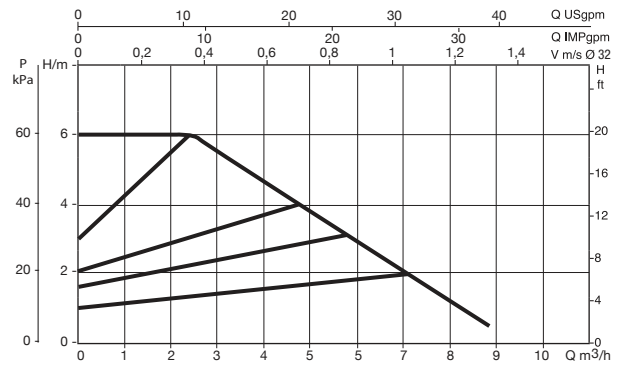

The curves are based on kinematic viscosity values = 1 mm²/s and density equal to 1000 kg/m³. Curve tolerance according to ISO 9906. Fixed speed curves available on the DNA.

MODEL	CENTRE DISTANCE mm	UNIONS ON REQUEST		COUNTERFLANGES ON REQUEST	POWER INPUT 50/60 Hz	P1 MAX W	In A	MINIMUM SUCTION PRESSURE			WEIGHT Kg
		STANDARDISED	SPECIAL					t°	90°	100°	
EVOPLUS B 40/220.32 SAN M	220	-	-	DN 32 PN 6	220/240 V	85	0,55	m.c.w.	20	25	8,6
EVOPLUS B 60/220.32 SAN M	220	-	-	DN 32 PN 6	220/240 V	110	0,75	m.c.w.	20	25	8,6

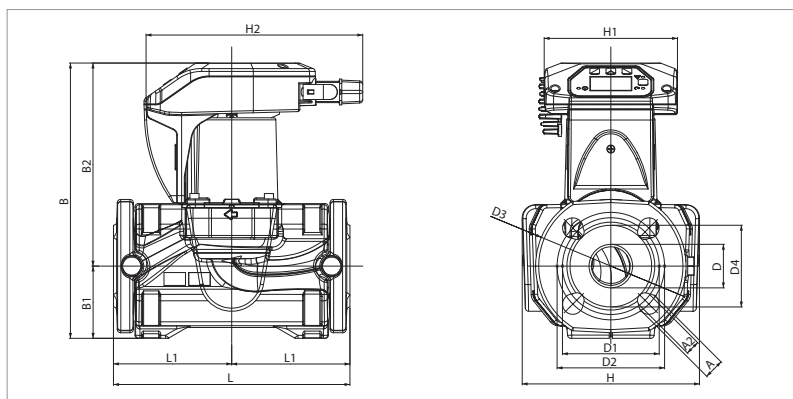

L	L1	L2	A	A2	B	B1	B2
220	110	110	19	14	256	67	189

D	D1	D2	D3	D4	H	H1	H2
40	90	100	140	76	165	124	204



EVOPLUS SMALL SAN - WET ROTOR ELECTRONIC CIRCULATORS

Pumped liquid temperature range: from -10 °C to +110 °C - Maximum operating pressure: 16 bar (1600 kPa)

EVOPLUS B 80/220.32 SAN M

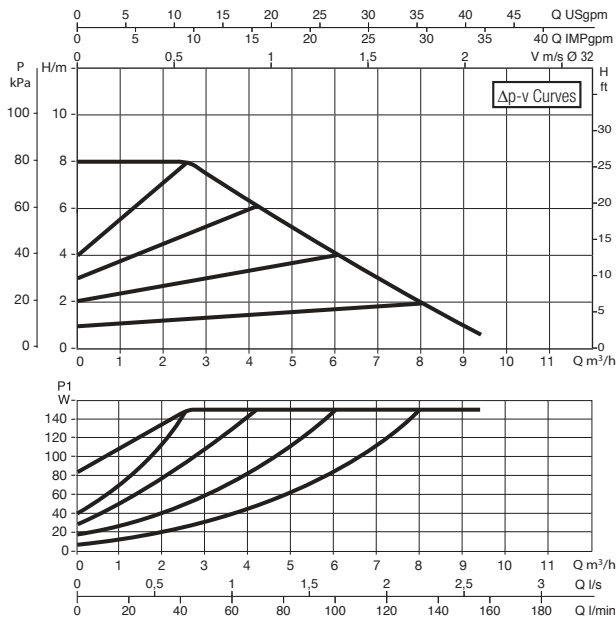

EVOPLUS B 110/220.32 SAN M

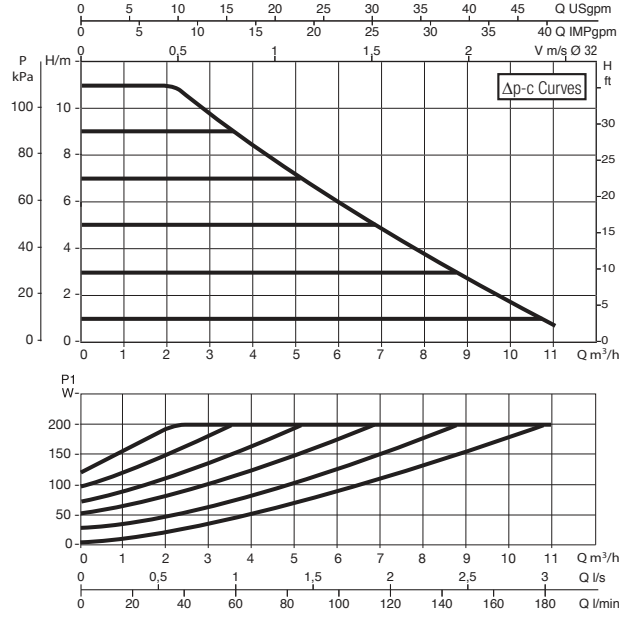
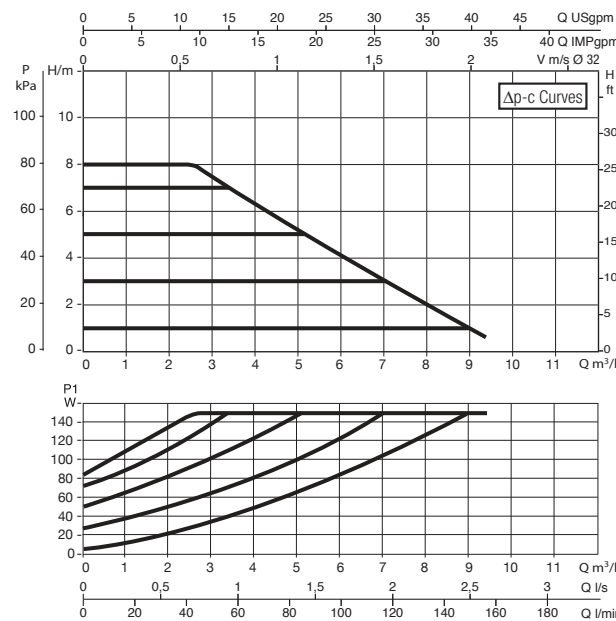
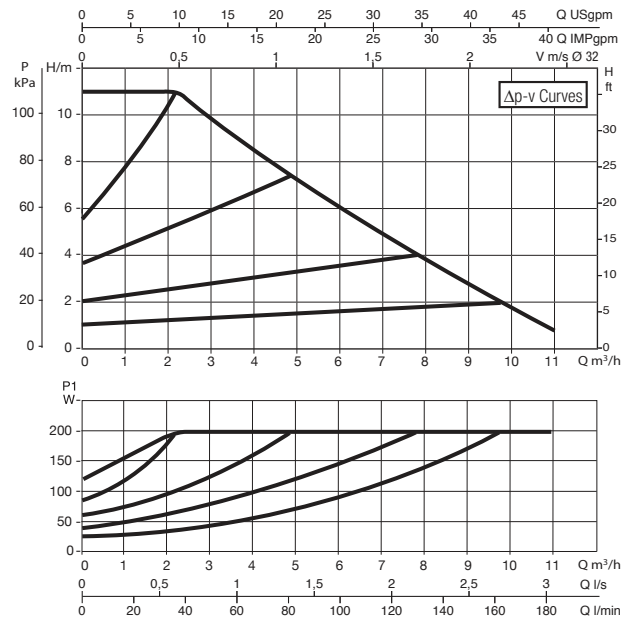

The curves are based on kinematic viscosity values = 1 mm²/s and density equal to 1000 kg/m³. Curve tolerance according to ISO 9906. Fixed speed curves available on the DNA.

MODEL	CENTRE DISTANCE mm	UNIONS ON REQUEST		COUNTERFLANGES ON REQUEST	POWER INPUT 50/60 Hz	P1 MAX W	In A	MINIMUM SUCTION PRESSURE			WEIGHT Kg
		STANDARDISED	SPECIAL					t°	90°	100°	
EVOPLUS B 80/220.32 SAN M	220	-	-	DN 32 PN 6	220/240 V	150	0,97	m.c.w.	20	25	8,6
EVOPLUS B 110/220.32 SAN M	220	-	-	DN 32 PN 6	220/240 V	200	1,3	m.c.w.	20	25	8,6

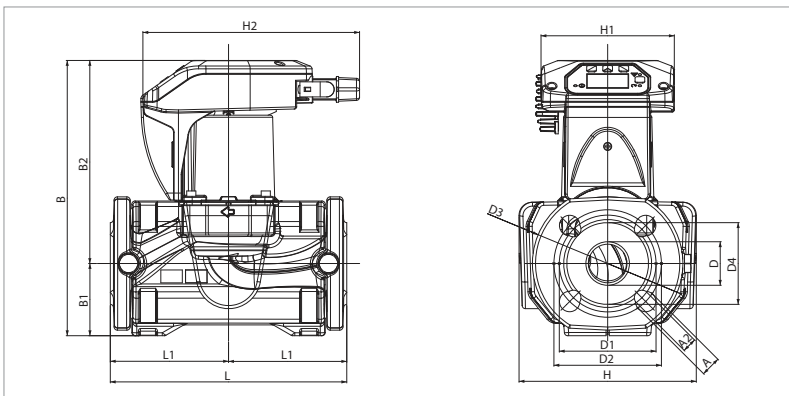

L	L1	L2	A	A2	B	B1	B2
220	110	110	19	14	256	67	189

D	D1	D2	D3	D4	H	H1	H2
40	90	100	140	76	165	124	204

EVOPLUS SMALL SAN - WET ROTOR ELECTRONIC CIRCULATORS

Pumped liquid temperature range: from -10 °C to +110 °C - Maximum operating pressure: 16 bar (1600 kPa)

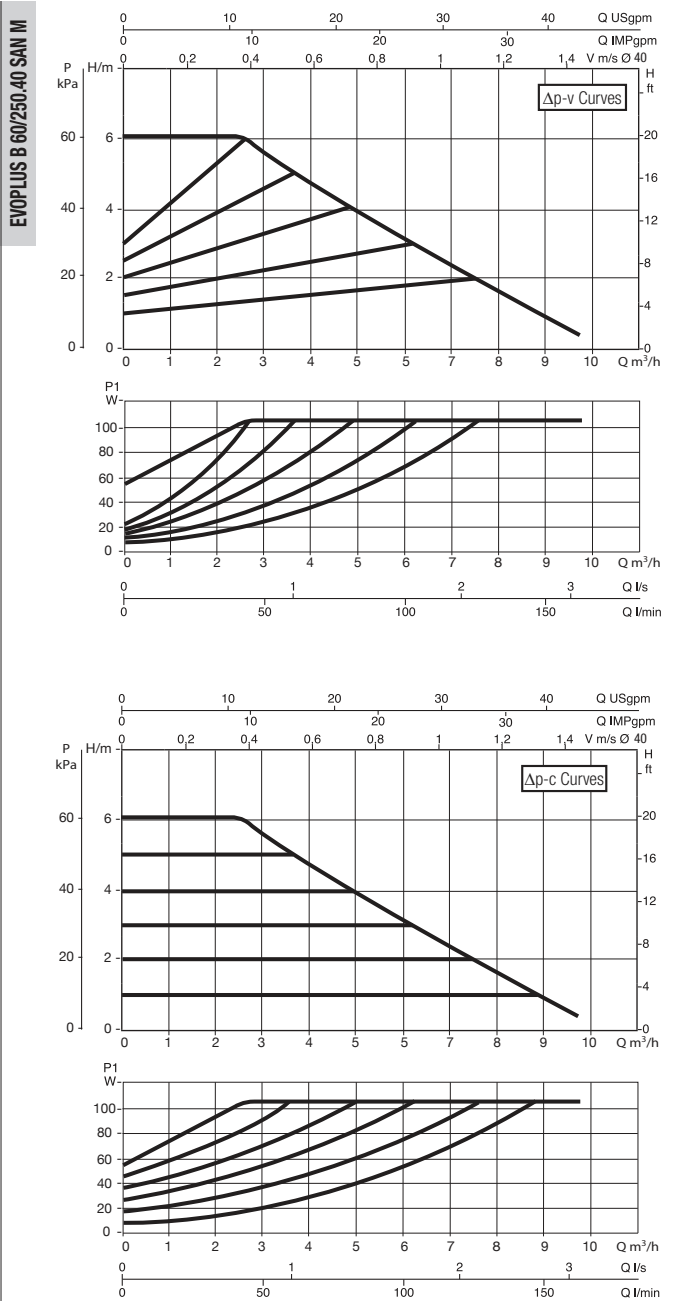
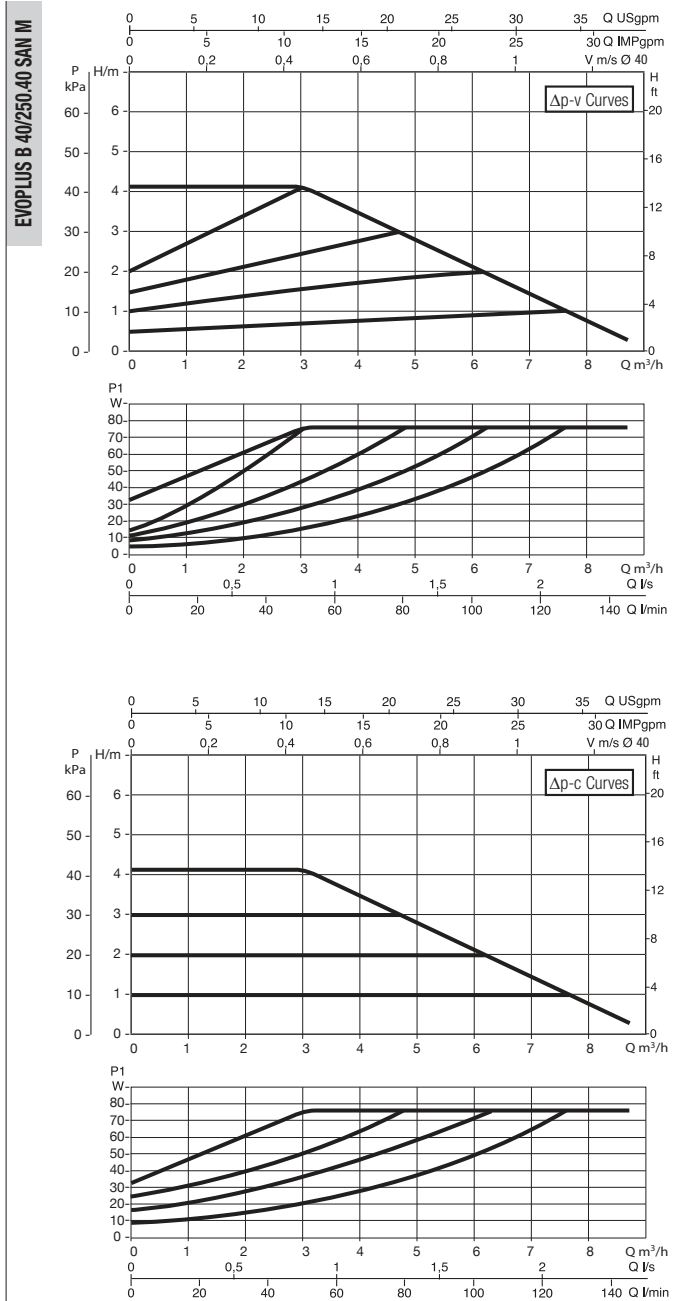

The curves are based on kinematic viscosity values = 1 mm²/s and density equal to 1000 kg/m³. Curve tolerance according to ISO 9906. Fixed speed curves available on the DNA.

MODEL	CENTRE DISTANCE mm	UNIONS ON REQUEST		COUNTERFLANGES ON REQUEST	POWER INPUT 50/60 Hz	P1 MAX W	In A	MINIMUM SUCTION PRESSURE			WEIGHT Kg
		STANDARDISED	SPECIAL					t°	90°	100°	
EVOPLUS B 40/250.40 SAN M	250	-	-	DN 40 PN 10	220/240 V	75	0,55	m.c.w.	20	25	9,3
EVOPLUS B 60/250.40 SAN M	250	-	-	DN 40 PN 10	220/240 V	105	0,75	m.c.w.	20	25	9,3

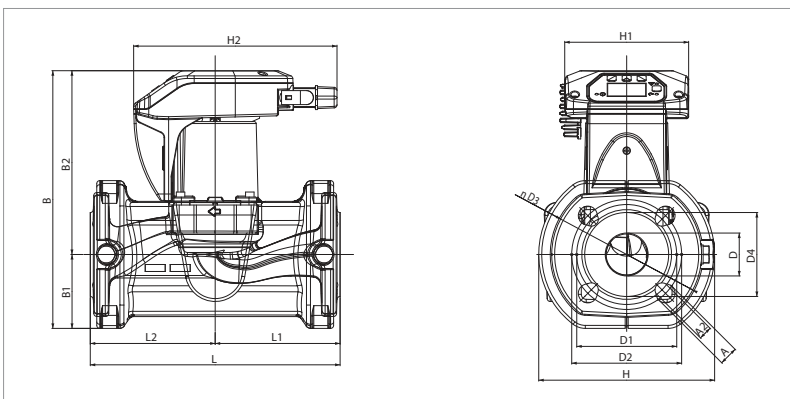

L	L1	L2	A	A2	B	B1	B2
250	125	125	19	14	258	74	184

D	D1	D2	D3	D4	H	H1	H2
43	100	110	150	84	176	124	204

EVOPLUS SMALL SAN - WET ROTOR ELECTRONIC CIRCULATORS

Pumped liquid temperature range: from -10 °C to +110 °C - Maximum operating pressure: 16 bar (1600 kPa)

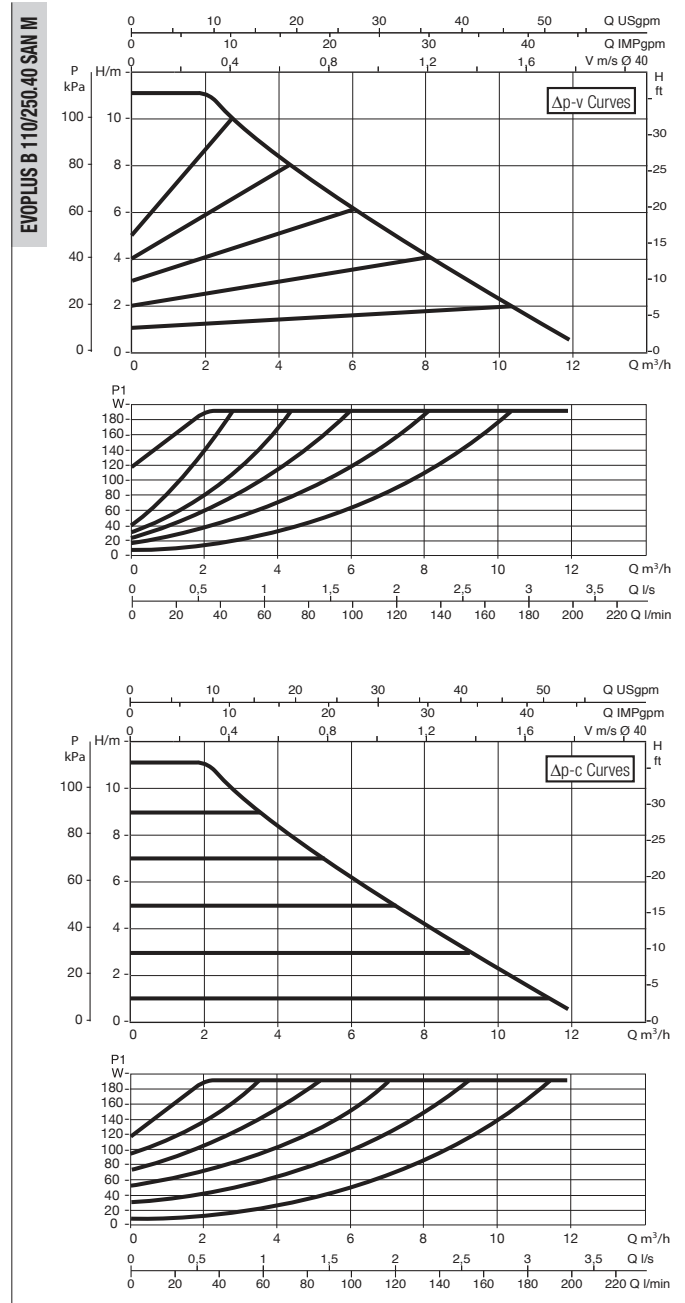
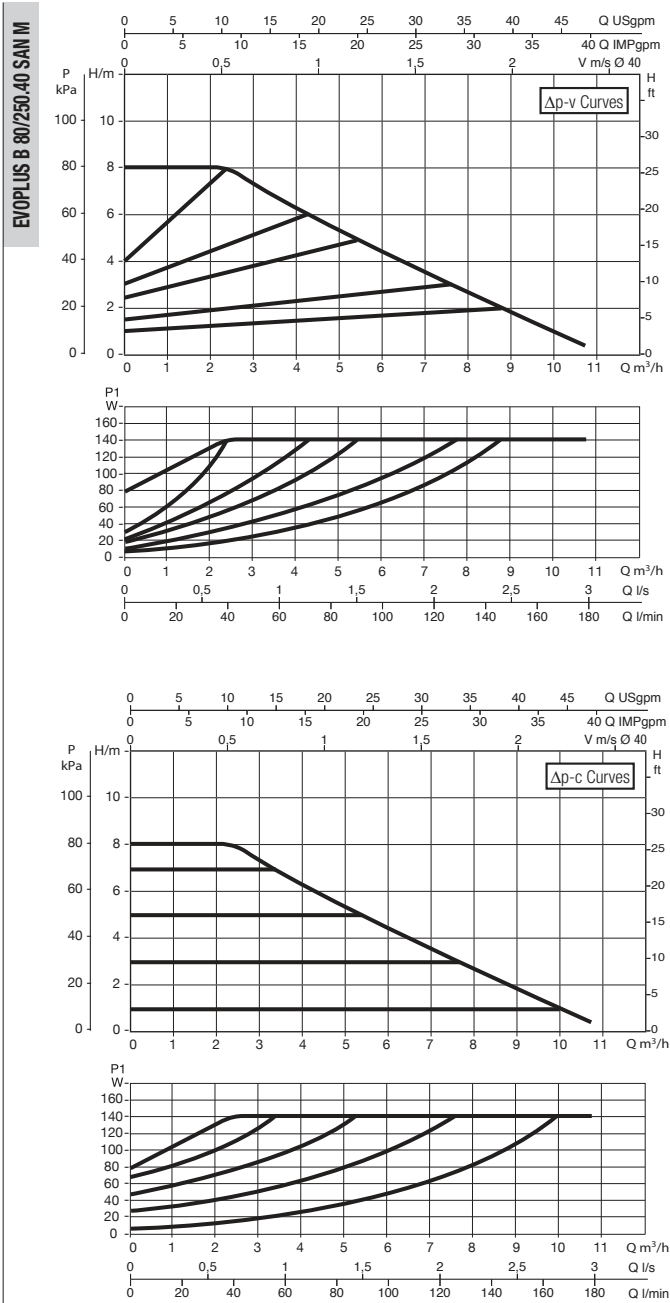

The curves are based on kinematic viscosity values = 1 mm²/s and density equal to 1000 kg/m³. Curve tolerance according to ISO 9906. Fixed speed curves available on the DNA.

MODEL	CENTRE DISTANCE mm	UNIONS ON REQUEST		COUNTERFLANGES ON REQUEST	POWER INPUT 50/60 Hz	P1 MAX W	I _n A	MINIMUM SUCTION PRESSURE			WEIGHT Kg
		STANDARDISED	SPECIAL					t°	90°	100°	
EVOPLUS B 80/250.40 SAN M	250	-	-	DN 40 PN 10	220/240 V	140	0,97	m.c.w.	20	25	9,3
EVOPLUS B 110/250.40 SAN M	250	-	-	DN 40 PN 10	220/240 V	190	1,3	m.c.w.	20	25	9,3

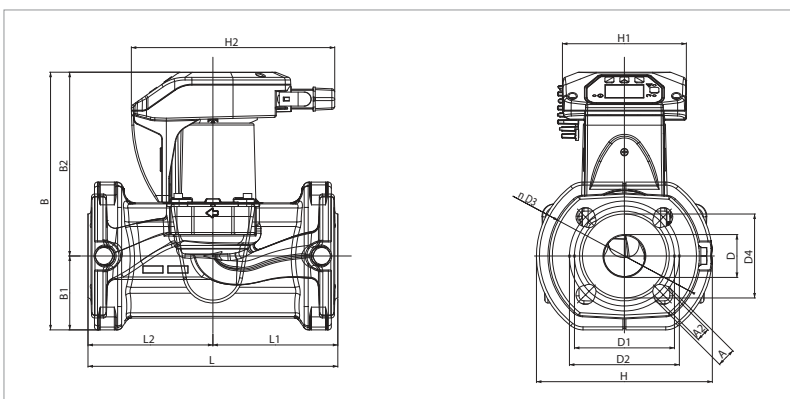

L	L1	L2	A	A2	B	B1	B2
250	125	125	19	14	258	74	184

D	D1	D2	D3	D4	H	H1	H2
43	100	110	150	84	176	124	204

EVOPLUS / EVOPLUS SAN

WET ROTOR ELECTRONIC CIRCULATORS



EVOPLUS



EVOPLUS SAN

TECHNICAL DATA

Operating range: from 3 a 75.6 m³/h with head of up to 18 metres.

Pumped liquid temperature range: from -10 °C to +110 °C.

Pumped liquid: clean, free of solids and mineral oils, non-viscous, chemically neutral, with properties similar to water. (glycol max 30%).

Maximum operating pressure: 16 bar (1600 kPa).

Standard flanges: DN 32, DN 40, DN 50, DN 65, PN 6 / PN 10 / PN 16 (4 holes), DN 80 and DN 100, PN 6 (4 holes).

Maximum ambient temperature: + 40 °C.

Minimum suction pressure: the values are shown in the corresponding tables.

Special executions on request: DN 80, DN 100 PN 10 / PN 16 (8 holes).

Accessories (Counter flanges): PN 10 DN 32 - DN 40 - DN 50 - DN 65
PN 6 DN 80 - DN 100.

Electromagnetic compatibility: EVOPLUS circulator comply with EN 61800-3 standard, category C2, as far as electromagnetic compatibility.

Electromagnetic emissions - Residential environment (containment measures might be required in some cases).

Conducted emissions - Residential environment (containment measures might be required in some cases).

APPLICATIONS

EVOPLUS circulation electronic pumps can be used in heating, ventilation, and air conditioning systems for residential and commercial buildings, like:

- Large residential buildings
- Private and public hospitals
- Real estate buildings
- Condominiums and small apartment buildings
- Schools
- Homes
- Office buildings

All the models are available both in the single and twin version.

Bronze pump execution for the recirculation of sanitary water, available in single version with DN 32, DN 40, DN 50 and DN 65 flanged ports.

Supplied as a standard ready for control using 0-10 V or PWM external signal, and for the connection to ModBus management systems (LonBus with appropriate communication module available as optional). **You can remotely control the single version thanks to the Dconnect service** (with Dconnect Box provided separately).

HEATING SYSTEM APPLICATIONS

The heating required for the different applications varies significantly during day and night, due to the external temperature, or the degree of occupancy inside the areas. To the above, one must add the different needs of the various environments, and the opening or closing of the various circuit branches of complex systems. Electronic wet rotor pumps ensure at all times, and virtually in all correctly sized systems, a sufficient level of energy, together with a quieter operation, and more comfort, together with an important reduction of operating costs.

AIR CONDITIONING APPLICATIONS

Unlike conventional electronic pumps, EVOPLUS electronic circulators can also be used in air conditioning systems where the temperature of the pumped liquid is lower than the room temperature. In these conditions, condensation tends to form on the outer surface of the circulator, which however does not affect the operation of the electronic and the mechanical components. The unit is designed and sized in such a way that it allows condensation to drain without damage to the construction components.

SANITARY RECIRCULATION APPLICATIONS

The SAN version, with bronze pump body, was specifically developed for the recirculation of sanitary water. With the constant temperature mode of operation, the temperature inside the recirculation piping is controlled without the need for thermostat valves, therefore optimizing comfort.

CONSTRUCTION FEATURES

Monobloc circulation pump consisting of the cast iron hydraulic section, and the wet rotor synchronous motor. Aluminium motor casing. Scroll type pump body featuring high hydraulic efficiency thanks to highly precise design and smooth internal surfaces. In-line suction and delivery ports.

The single version is supplied as standard with insulating casing, to avoid heat dispersion and/or the formation of condensation on the pump body.

For the twin version, the insulation must be provided by the installer. In any case, pay attention not to obstruct the condensation drainage ducts, to avoid impairing the operation of the circulator.

Technopolymer impeller, stainless steel motor shaft on ceramic bushings lubricated by the pumped liquid. Stainless steel rotor protection liner. Ceramic thrust ring, ethylene-propylene seal rings and carbon fibre composite stator liner. Asynchronous motor with permanent magnet rotor. The twin version features an automatic swing check valve incorporated in the delivery port, to avoid water recirculating through the unit when this is not running; in addition, a blank flange is also supplied as standard, to allow either of the two motors to be removed for servicing. The standard execution of the pump body is PN 16. DN 80 and DN 100 PN 16 (8 holes) also available on request.

Circulator protection class: IP X4D

Insulation class: F

Standard voltage: single-phase 220/240 V / 50/60 Hz

sound pressure value ≤ 45 dB(A)

Product compliant with European Standards EN 61800-3 – EN 60335-1 – EN 60335-2-51



DCONNECT SERVICE

REMOTE CONTROL FOR ELECTRONIC RESIDENTIAL AND COMMERCIAL SYSTEMS

The Dconnect service offers simple and intuitive remote control of your installation, without the need of a server or specialist personnel.

With Dconnect, you can remotely manage your installations as if you were right in front of them.

Thanks to the system operation charts, you will also be able to optimise operation. You will also receive prompt notifications of any system faults.

THE CONNECTIVITY SERVICE ALLOWS YOU TO:

EASILY MONITOR YOUR SYSTEMS

The installations with green status are OK, while the orange ones need attention, and the red ones are experiencing problems

TAKE ANY NECESSARY ACTIONS AS IF YOU WERE RIGHT IN THE PUMP ROOM

Using the internet site or the APPs, you will be able to easily and quickly control your systems.

DCONNECT SERVICE

REMOTE CONTROL FOR ELECTRONIC RESIDENTIAL AND COMMERCIAL SYSTEMS

In order to use the Dconnect service, registration and connected products are required.

Connect to the website: <https://dconnect.dabpumps.com>, using Internet Browsers such as Microsoft Edge or Google Chrome.

The Android and iOS Dconnect APPs can be downloaded from the relevant Stores:



REMOTE ALARMS

In case of alarm, the Dconnect service will promptly send you a notification, so that you can check what is happening and organise a visit to the system before the issue becomes an emergency for your customer.

WHAT PRODUCTS CAN YOU MANAGE USING THE DCONNECT SERVICE?

MCE/P, MCE/C, ADAC, Active driver Plus, Ebox, Evoplus, Eskybox, Eskybox mini, Eskybox Diver, Dtron 3.

WHAT DO YOU NEED TO USE THE SERVICE?

1. DConnect Box
2. Cables for the connection of the DConnect Box / Dconnect Box 2 to the products to control
3. One or more compatible products
4. An internet connection in the system to control

For more information visit: internetofpumps.com

EVOPLUS / EVOPLUS SAN

WET ROTOR ELECTRONIC CIRCULATORS

EVOPLUS CONSTRUCTION CHARACTERISTICS COLLECTIVE SYSTEMS (ELECTRONIC DEVICE)*

EVOPLUS circulators are controlled by a latest generation NPT technology IGBT device, for better efficiency and strength. The specific features are:

- Sine-wave PWM modulation
- High carrier frequency to eliminate all audio band noise
- 2 dedicated 32 bit processors
one for driving the motor
one for the user interface, enabling to perform the following functions:
 - start/stop command
 - Economy command
 - 0-10 V analogue signal command
 - PWM signal command
 - 4-20 mA analogue signal command
 - ΔT temperature sensor signal command
- connection to ModBus system management devices. Optional LonBus with appropriate module.
- Optimised "space vector" algorithm
- Presence/absence of system alarms
- Pump in operation notification

* Inputs only available if the associated function is active.

An intuitive and functional user interface guarantees ease of calibration by all users. The easy to read OLED display on the control panel, three simple navigation keys, an in-line cascade menu featuring the latest mobile technology trends, and a wide range of functions, mean that EVOPLUS circulators are truly revolutionary products. A reliable and sturdy construction, together with a modern and innovative design, complete the product, also in terms of aesthetic value.

MATERIALS

N.	PARTS	MATERIALS
1	PUMP BODY	CAST IRON 250 UNI ISO 185 - CTF BRONZE (for the SAN version)
4	IMPELLER	TECHNOPOLYMER
7A	MOTOR SHAFT	STAINLESS STEEL
7B	ROTOR	STAINLESS STEEL LINER
8	STATOR	-
10	MOTOR CASING	DIE-CAST ALUMINIUM
127	SEAL RING	EPDM RUBBER
128	STATOR LINER	COMPOSITE AND CARBON FIBRE
130	CLOSING FLANGE	STAINLESS STEEL
131	THRUST RING SUPPORT	STAINLESS STEEL
132	BUSHINGS	ALLUMINA

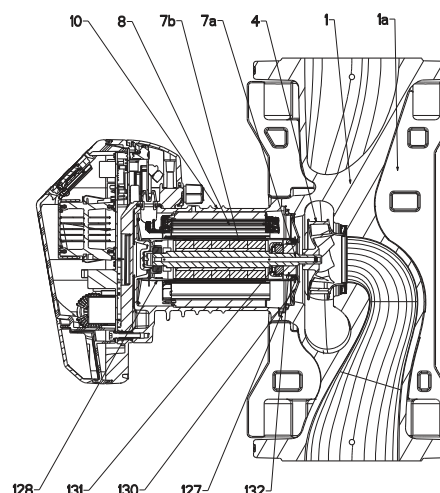

- Legend: (example)

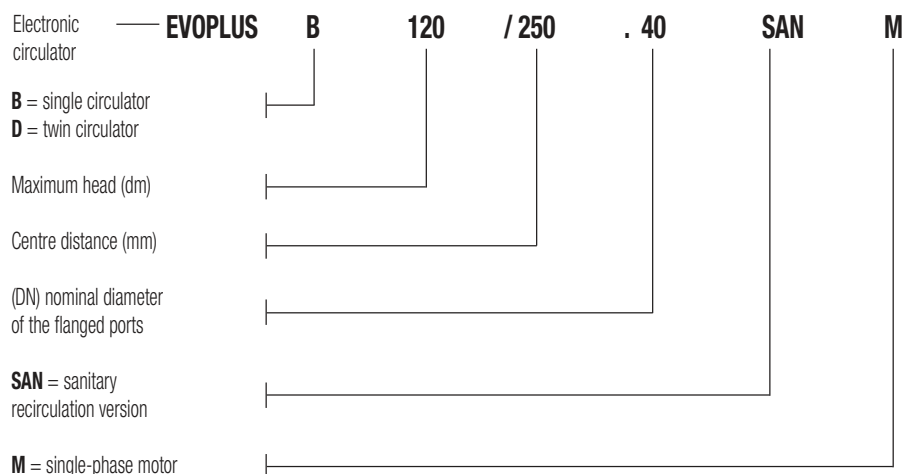

EVOPLUS / EVOPLUS SAN

WET ROTOR ELECTRONIC CIRCULATORS

MODES OF OPERATION

All the functions listed below can be consulted by the users (including less experienced ones) by simply scrolling through the menu. The calibration and the modification of the parameters are protected, and can only be completed by expert users. The factory settings of the EVOPLUS range are for proportional differential pressure control mode in the curve that ensures the best energy efficiency index (EEI).

1 - ΔP -v proportional differential pressure adjustment mode

With ΔP -v adjustment mode, with the variation of the flow rate, the value of the delivery of the head also varies in a linear manner, from H_{setp} to $H_{setp}/2$.

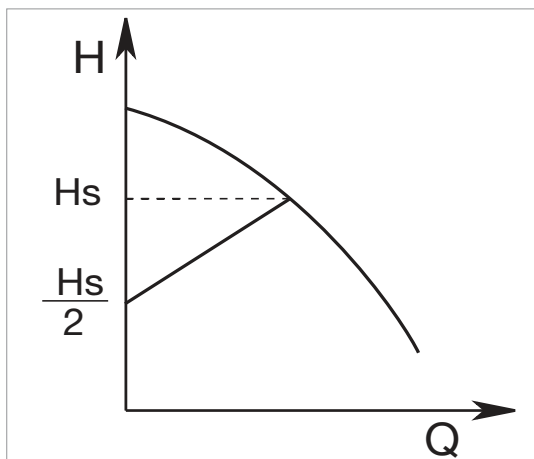

This adjustment is particularly indicated for the following systems:

a. Two-pipe heating systems with thermostat valves and with:

- head greater than 4 metres;
- very long circuit piping;
- valves with wide operating range;
- differential pressure regulators;
- high pressure drops in those parts of the system carrying the entirety of the water flow rate;
- low differential pressure.

b. Under-floor central heating systems with thermostatic valves and significant pressure drops in the boiler circuit.

c. Systems with primary circuit pumps with high pressure drops.

Example of set-up of the set-point with ΔP -v

The following operating point is required:

$$Q = 6,5 \text{ m}^3/\text{h}$$

$$H = 6 \text{ m}$$

PROCEDURE:

1. In the graph, find the desired operating point, and then find the EVOPLUS curve closest to it (in this case the point lies precisely on the curve)
2. Follow the curve upwards until reaching the intersection with the limit curve of the circulator.
3. The head reading at this limit point is the set-point head that must be entered to obtain the desired operating point.

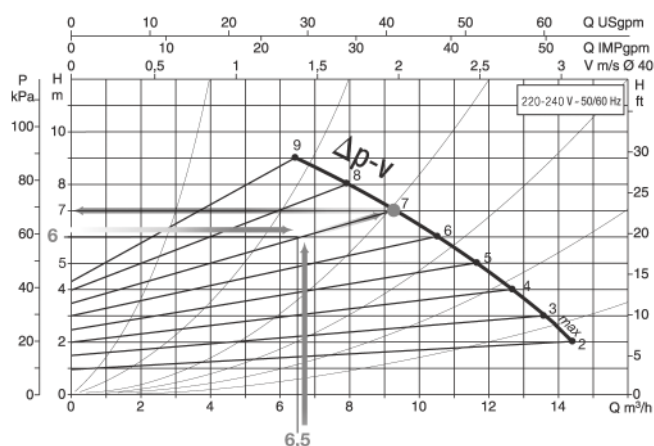

2 - ΔP -c constant differential pressure adjustment mode

The ΔP -c adjustment mode keeps the differential pressure of the system constantly at the H_{setp} value set, even in case of variation of the flow rate.

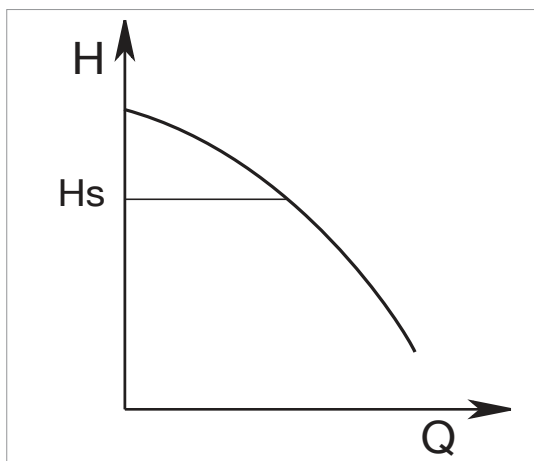

This adjustment is particularly indicated for the following systems:

a. Two-pipe heating systems with thermostat valves and with:

- head lower than 2 metres;
- natural circulation;
- low pressure drops in those parts of the system carrying the entirety of the water flow rate;
- high differential temperature (central heating).

b. underfloor heating systems with thermostat valves

c. single-pipe heating systems with thermostat valves and calibration valves

d. Systems with primary circuit pumps with low pressure drops.

3 - Constant curve adjustment modes

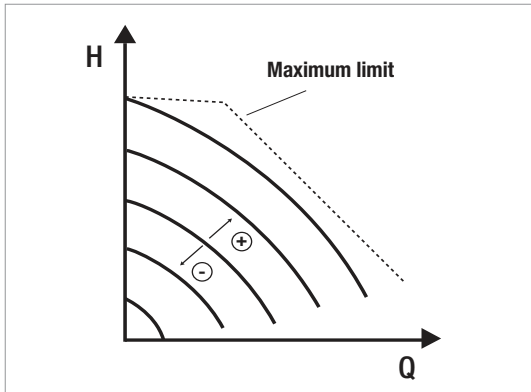

In this control mode, the circulator works based on constant speed characteristic curves. The operation curve is selected by setting the rotation speed using a percentage factor. The 100 % value indicates the maximum limit curve. The actual rotation speed may be affected by the power and differential pressure limitations of the actual circulator model. The rotation speed may be set using the display, or either a 0-10 V or PWM external signal.

Control mode indicated for constant flow rate heating and air conditioning systems.

4 - Constant differential pressure control mode with proportional control based on the water temperature

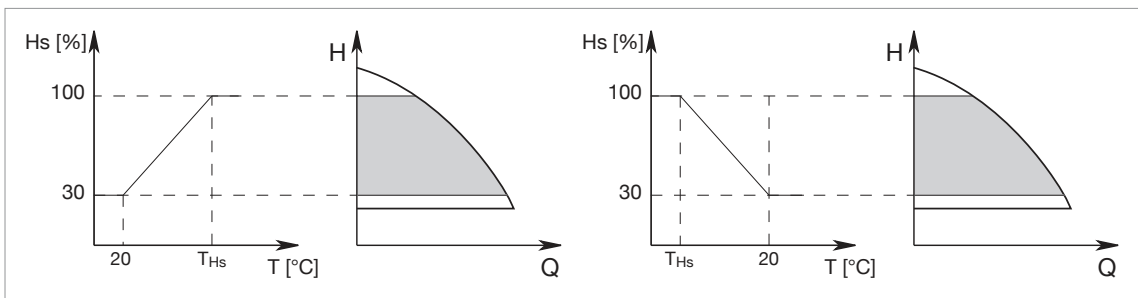

The circulator head set-point is reduced in accordance with the water temperature. The liquid temperature can be set between 0 °C to 100 °C.

This adjustment is particularly indicated for the following systems:

- in variable flow rate systems (two-pipe central heating systems), for which a further reduction of the circulator performance levels is provided in accordance with the lowering of the temperature of the circulating liquid, in case of reduced heating demand.
- in constant flow rate systems (single-pipe and under-floor central heating systems), where the performance of the circulator can only be adjusted by activating the temperature influence function. It is set through the EVOPLUS control panel.

5 - ΔT -c * constant differential temperature adjustment mode

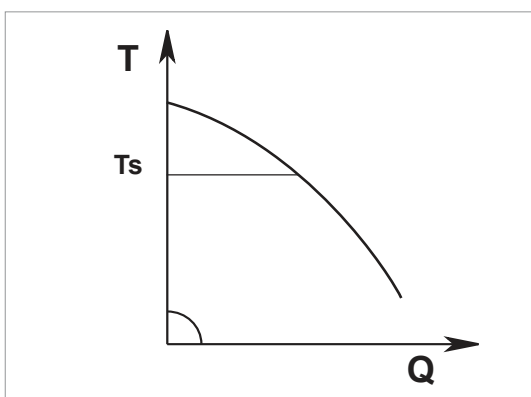

The ΔT -c control mode keeps the pumped liquid at constant temperature, changing the flow rate to the Tsetp settable value.

This adjustment is particularly indicated for the following systems:

- Under-floor heating systems.
- Systems with circuit pumps with heat exchanger.
- Solar energy systems with storage tanks.
- Solar panel swimming pool heating systems.

* Adjustment during implementation.

ECONOMY MODE

The economy function can be set directly on the control panel, by setting a reduction value (f.rid), the maximum value of which can be 50%. In all the previously listed settings, the Hset value must be replaced with an Hset x f.rid.

EVOPLUS / EVOPLUS SAN

WET ROTOR ELECTRONIC CIRCULATORS

CONNECTION DIAGRAM

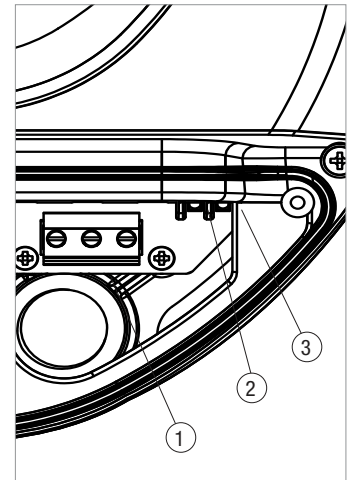
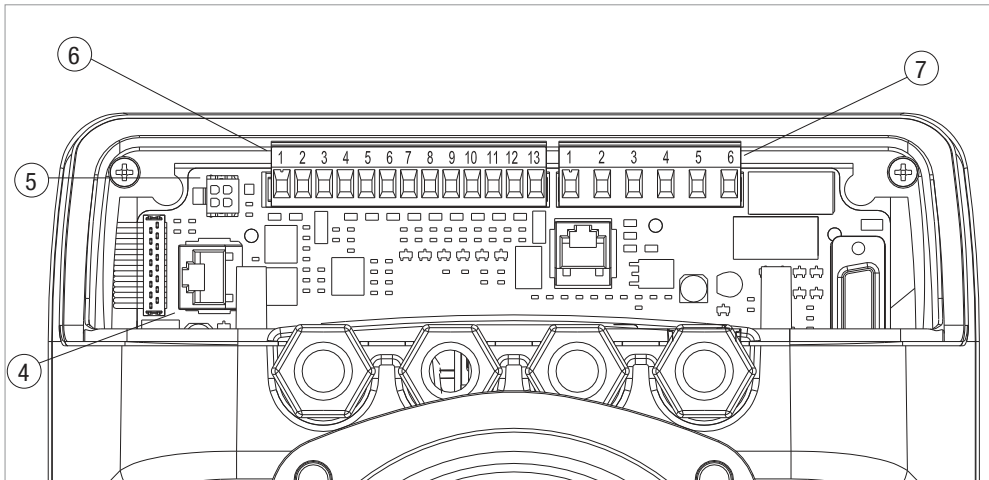

1	Removable terminal box for the connection of the power input line: 1x220-240 V, 50/60 Hz
2	Auxiliary LED
3	High voltage LED
4	Connector for twin circulators
5	Connector for pressure and temperature sensor on the circulator (as standard)
6	Removable 13-pole terminal box for the connection of MODBUS systems and inputs
7	Removable 6-pole terminal box for system status and alarm notification

POWER INPUT CONNECTION

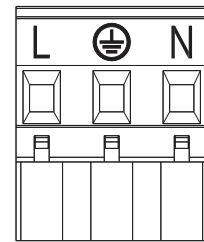

Removable power input terminal box

USER INTERFACE

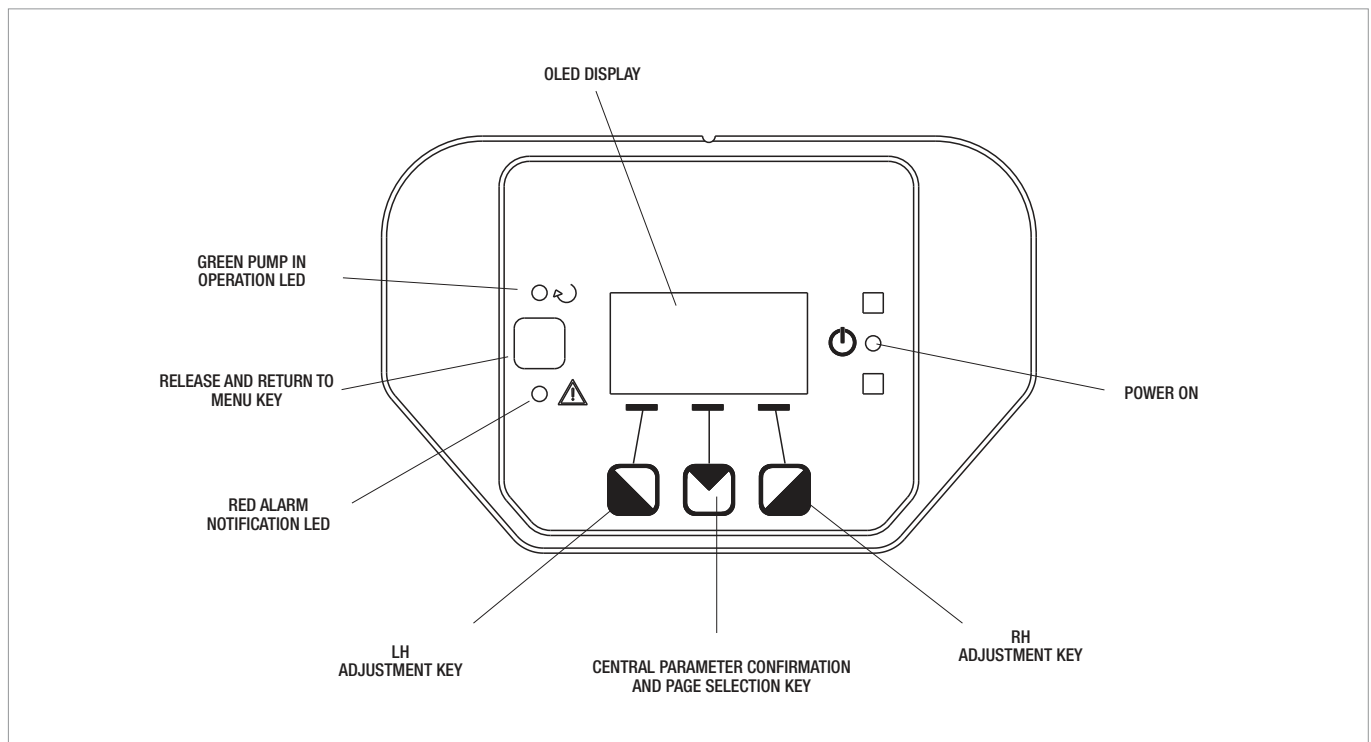

EVOPLUS / EVOPLUS SAN

WET ROTOR ELECTRONIC CIRCULATORS

Digital inputs

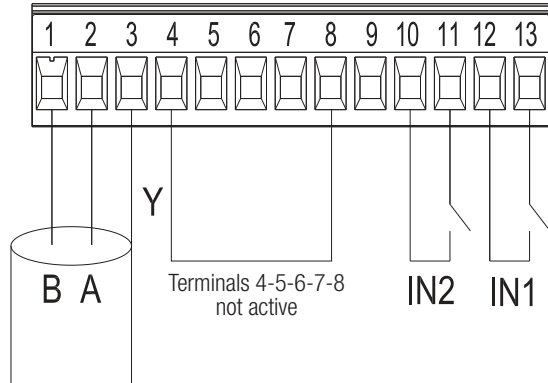

Input	Terminal no.	Type of contact	Associated function
IN1	12	Clean contact	EXT: If it is activated from the control panel, it will be possible to remotely control the switching on and off of the pump.
	13		
IN2	10	Clean contact	Economy: If it is activated from the control panel, it will be possible to remotely activate the set-point reduction function.
	11		

If the **EXT** and **Economy** functions have been activated using the control panel, the system will behave as follows:

IN1	IN2	System status
Open	Open	Pump stopped
Open	Close	Pump stopped
Close	Open	Pump in operation with set-point set by the user
Close	Close	Pump in operation with reduced set-point

MODBUS

EVOPLUS circulators provide serial communication through an RS-485 input. The communication is established in accordance with the MODBUS specifications. Using the MODBUS, it is possible to remotely set the circulator operating parameters, like the desired differential pressure, the temperature influence, the control mode, etc. At the same time, the circulator can provide important information on the status of the system.

Modbus terminals	Terminal no.	Description
A	2	Terminal not inverted (+)
B	1	Terminal inverted (+)
Y	3	GND

LONBUS

Using some modules available on the market, the circulator, and therefore its status, can also be made available to a LonWorks network. It will then be possible to change the parameters of the circulator by reading and amending the registers as indicated in the "Modbus Protocol instruction manual", available at the following address: "<http://www.dabpumps.it/evoplus>".

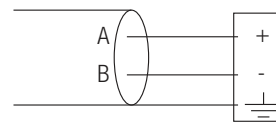

Gateway/ Evoplus connection

ANALOGUE AND PWM INPUT

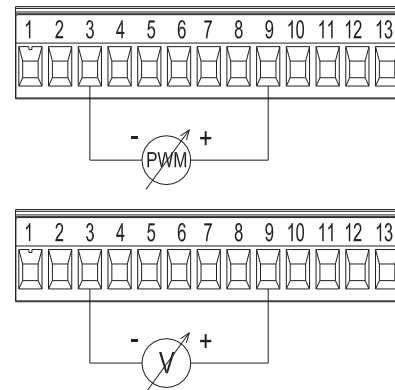

Connection diagram for the external 0-10 V and PWM signals. The 2 signals share the same terminals of the terminal box, and therefore are mutually exclusive.

Digital outputs

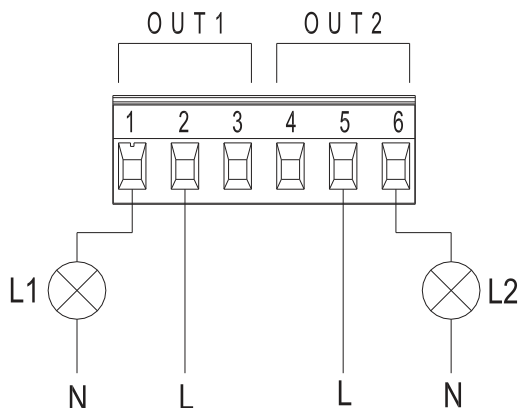

Light L1 comes on when the system includes an alarm, and goes off when no faults are detected, while light L2 comes on when the pump is in operation, and goes off when the pump is stopped.

OUTPUT	TERMINAL NO.	TYPE OF CONTACT	ASSOCIATED FUNCTION
OUT1	1	NC	Presence/absence of system alarms
	2	COM	
	3	NO	
OUT2	4	NC	Pump in operation/Pump stopped
	5	COM	
	6	NO	

Outputs OUT1 and OUT2 are available on the 6-pole removable terminal box, where the type of contact is also shown (NC = Normally Closed, COM = Common, NO = Normally Open).

CHARACTERISTICS OF THE OUTPUT CONTACTS

Max sustainable voltage [V]	250
Max sustainable current [A]	5 - If resistive load 2,5 - If inductive load
Max cable section accepted [mm ²]	1,5

EVOPLUS RANGE

WET ROTOR ELECTRONIC CIRCULATORS

PERFORMANCE RANGE

The performance curves are based on kinematic viscosity values = 1 mm²/s and density equal to 1000 kg/m³. Curve tolerance according to ISO 9906.

GRAPHIC SELECTION TABLE

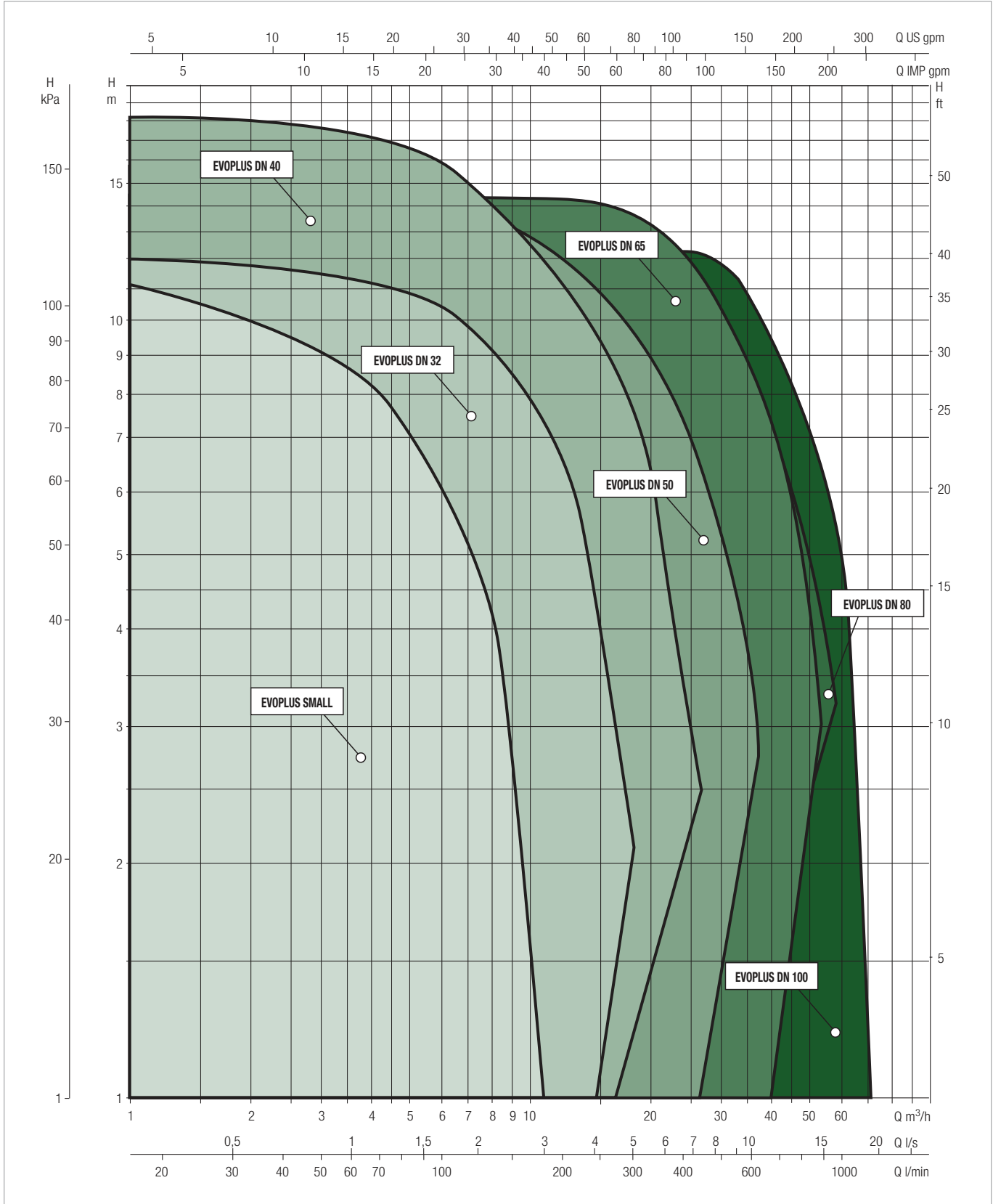

EVOPLUS / EVOPLUS SAN

WET ROTOR ELECTRONIC CIRCULATORS

SELECTION TABLE - EVOPLUS

MODEL	Q=m ³ h	0	4,2	5,4	7,2	9,6	12	14,4	18	24	30	36	42	54	72	
	Q=l/min	0	70	90	120	160	200	240	300	400	500	600	700	900	1200	
EVOPLUS B 120/220.32 M	H (m)	12,1	11,5	10,7	9,5	7,9	6,3	4,7	2,2							
EVOPLUS B 40/220.40 M		4	3,6	3,1	2,5	1,7										
EVOPLUS B 60/220.40 M		6		5,9	5,1	4,1	3	2								
EVOPLUS B 80/220.40 M		8		7,9	7,4	6,1	5	3,7	2							
EVOPLUS B 100/220.40 M		10			9,7	8,3	7	5,5	3,5							
EVOPLUS B 120/250.40 M		12			11,5	10,1	8,7	7,3	5,2							
EVOPLUS B 150/250.40 M		15			14,5	12,8	11,3	9,7	7,5	3,8						
EVOPLUS B 180/250.40 M		18		16,2	14,6	13	11,2	9,6	7,4	3,9						
EVOPLUS B 40/240.50 M		4		3,9	3,6	3,1	2,6	2,1	1,4							
EVOPLUS B 60/240.50 M		6				5,4	4,7	4	3,2	1,6						
EVOPLUS B 80/240.50 M		8			7,4	6,6	5,9	5,2	4,2	2,6						
EVOPLUS B 100/280.50 M		10			9,4	8,4	7,5	6,7	5,5	3,6	2					
EVOPLUS B 120/280.50 M		12			11	9,9	9	8,2	6,9	4,8	3					
EVOPLUS B 150/280.50 M		15,3			12,4	11,5	10,6	9,6	8,3	6,2	4,2					
EVOPLUS B 180/280.50 M		17,1			14	13	12	11,1	9,7	7,4	5,2	3,1				
EVOPLUS B 40/340.65 M		4			4	3,8	3,4	3	2,4	1,4						
EVOPLUS B 60/340.65 M		6				6	5,9	5,4	4,7	3,7	2,2					
EVOPLUS B 80/340.65 M		8				7,8	7,4	6,8	5,9	4,6	3,5	2				
EVOPLUS B 100/340.65 M		10,1				9,8	9,1	8,4	7,6	6,1	4,7	3,1				
EVOPLUS B 120/340.65 M		12				11,5	10,8	10	9	7,4	5,9	4,6	2,8			
EVOPLUS B 150/340.65 M		15,2					14,9	14,7	14	12,1	10,3	8,5	6,9			
EVOPLUS B 40/360.80 M		4							4	3,1	2,2	1,4				
EVOPLUS B 60/360.80 M		6							6	5,2	4	3	2			
EVOPLUS B 80/360.80 M		8							8	6,7	5,4	4,2	3,2			
EVOPLUS B 100/360.80 M		10								9,7	8,3	6,7	5,4	3		
EVOPLUS B 120/360.80 M		12,1								11,6	9,9	8,3	6,8	4,1		
EVOPLUS B 40/450.100 M		4									3,9	3	2			
EVOPLUS B 60/450.100 M		6									5,7	4,7	3,6	1,3		
EVOPLUS B 80/450.100 M		8									8	7,2	5,7	3,4		
EVOPLUS B 100/450.100 M		10,1									10,1	9,2	7,6	4,9	0,7	
EVOPLUS B 120/450.100 M		12,2									11,8	10,4	8,7	5,9	1,5	

EVOPLUS / EVOPLUS SAN

WET ROTOR ELECTRONIC CIRCULATORS

SELECTION TABLE - EVOPLUS

MODEL	Q=m³h	0	4,2	5,4	7,2	9,6	12	14,4	18	24	30	36	42	54	72	
	Q=l/min	0	70	90	120	160	200	240	300	400	500	600	700	900	1200	
EVOPLUS D 120/220.32 M	H (m)	12,1	11,5	10,7	9,5	7,9	6,3	4,7	2,2							
EVOPLUS D 40/220.40 M		4	3,6	3,1	2,5	1,7										
EVOPLUS D 60/220.40 M		6		5,9	5,1	4,1	3	2								
EVOPLUS D 80/220.40 M		8		7,9	7,4	6,1	5	3,7	2							
EVOPLUS D 100/220.40 M		10				9,7	8,3	7	5,5	3,5						
EVOPLUS D 120/250.40 M		12				11,5	10,1	8,7	7,3	5,2						
EVOPLUS D 150/250.40 M		15				14,5	12,8	11,3	9,7	7,5	3,8					
EVOPLUS D 180/250.40 M		18		16,2	14,6	13	11,2	9,6	7,4	3,9						
EVOPLUS D 40/240.50 M		4		3,9	3,6	3,1	2,6	2,1	1,4							
EVOPLUS D 60/240.50 M		6				5,4	4,7	4	3,2	1,6						
EVOPLUS D 80/240.50 M		8				7,4	6,6	5,9	5,2	4,2	2,6					
EVOPLUS D 100/280.50 M		10				9,4	8,4	7,5	6,7	5,5	3,6	2				
EVOPLUS D 120/280.50 M		12				11	9,9	9	8,2	6,9	4,8	3				
EVOPLUS D 150/280.50 M		15,3				12,4	11,5	10,6	9,6	8,3	6,2	4,2				
EVOPLUS D 180/280.50 M		17,1				14	13	12	11,1	9,7	7,4	5,2	3,1			
EVOPLUS D 40/340.65 M		4			4	3,8	3,4	3	2,4	1,4						
EVOPLUS D 60/340.65 M		6				6	5,9	5,4	4,7	3,7	2,2					
EVOPLUS D 80/340.65 M		8				7,8	7,4	6,8	5,9	4,6	3,5	2				
EVOPLUS D 100/340.65 M		10,1				9,8	9,1	8,4	7,6	6,1	4,7	3,1				
EVOPLUS D 120/340.65 M		12				11,5	10,8	10	9	7,4	5,9	4,6	2,8			
EVOPLUS D 150/340.65 M		15,2					14,9	14,7	14	12,1	10,3	8,5	6,9			
EVOPLUS D 40/360.80 M		4							4	3,1	2,2	1,4				
EVOPLUS D 60/360.80 M		6							6	5,2	4	3	2			
EVOPLUS D 80/360.80 M		8							8	6,7	5,4	4,2	3,2			
EVOPLUS D 100/360.80 M		10								9,7	8,3	6,7	5,4	3		
EVOPLUS D 120/360.80 M		12,1								11,6	9,9	8,3	6,8	4,1		
EVOPLUS D 40/450.100 M		4									3,9	3	2			
EVOPLUS D 60/450.100 M		6									5,7	4,7	3,6	1,3		
EVOPLUS D 80/450.100 M		8									8	7,2	5,7	3,4		
EVOPLUS D 100/450.100 M		10,1									10,1	9,2	7,6	4,9	0,7	
EVOPLUS D 120/450.100 M		12,2									11,8	10,4	8,7	5,9	1,5	

SELECTION TABLE - EVOPLUS SAN

MODEL	Q=m ³ h	0	4,2	5,4	7,2	9,6	12	14,4	18	24	30	36	42	54	72
	Q=l/min	0	70	90	120	160	200	240	300	400	500	600	700	900	1200
EVOPLUS B 120/220.32 SAN M		12,1	11,5	10,7	9,5	7,9	6,3	4,7	2,2						
EVOPLUS B 120/250.40 SAN M		12			11,5	10,1	8,7	7,3	5,2						
EVOPLUS B 150/250.40 SAN M		15			14,5	12,8	11,3	9,7	7,5	3,8					
EVOPLUS B 180/250.40 SAN M		18		16,2	14,6	13	11,2	9,6	7,4	3,9					
EVOPLUS B 100/280.50 SAN M		10			9,4	8,4	7,5	6,7	5,5	3,6	2				
EVOPLUS B 120/280.50 SAN M		12			11	9,9	9	8,2	6,9	4,8	3				
EVOPLUS B 150/280.50 SAN M		15,3			12,4	11,5	10,6	9,6	8,3	6,2	4,2				
EVOPLUS B 180/280.50 SAN M		17,1			14	13	12	11,1	9,7	7,4	5,2	3,1			
EVOPLUS B 40/340.65 SAN M		4			4	3,8	3,4	3	2,4	1,4					
EVOPLUS B 60/340.65 SAN M		6				6	5,9	5,4	4,7	3,7	2,2				
EVOPLUS B 80/340.65 SAN M		8				7,8	7,4	6,8	5,9	4,6	3,5	2			
EVOPLUS B 100/340.65 SAN M		10,1				9,8	9,1	8,4	7,6	6,1	4,7	3,1			
EVOPLUS B 120/340.65 SAN M		12				11,5	10,8	10	9	7,4	5,9	4,6	2,8		
EVOPLUS B 150/340.65 SAN M		15,2					14,9	14,7	14	12,1	10,3	8,5	6,9		

EVOPLUS - WET ROTOR ELECTRONIC CIRCULATORS

Pumped liquid temperature range: from -10 °C to +110 °C - Maximum operating pressure: 16 bar (1600 kPa)

EVOPLUS B 120/220.32 M

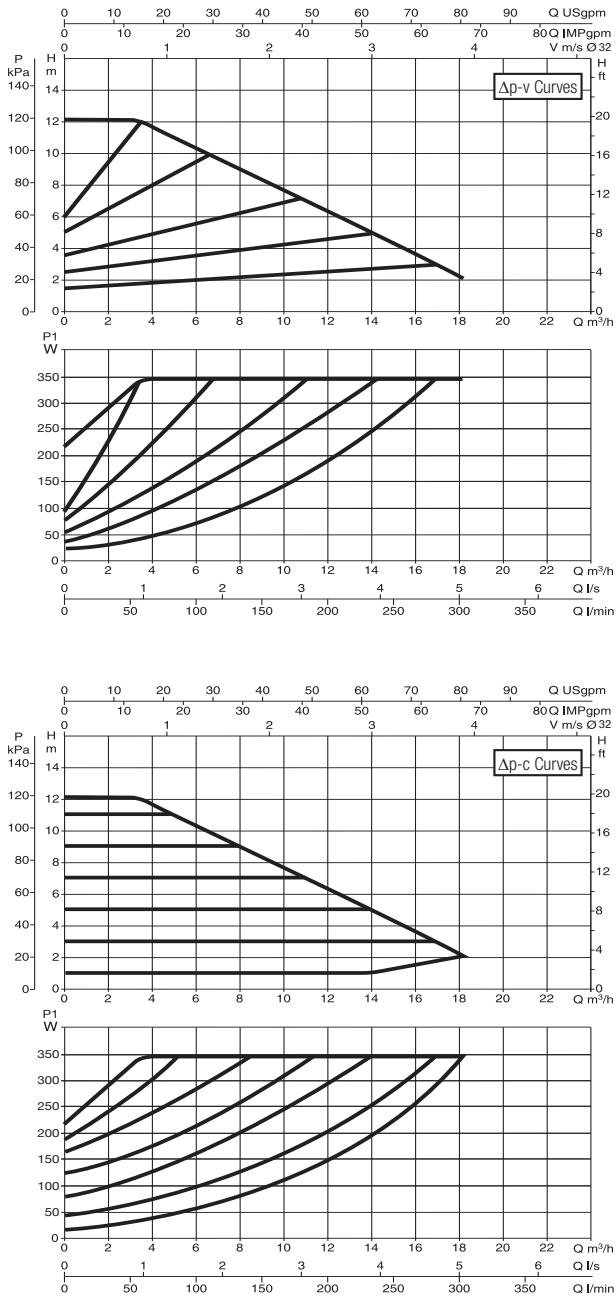

The curves are based on kinematic viscosity values = 1 mm²/s and density equal to 1000 kg/m³. Curve tolerance according to ISO 9906. Fixed speed curves available on the DNA.

MODEL	CENTRE DISTANCE mm	COUNTERFLANGES ON REQUEST	POWER INPUT 50/60 Hz	P1 MAX W	In A	EEI*	MINIMUM SUCTION PRESSURE			WEIGHT Kg
							t°	90°	100°	
EVOPLUS B 120/220.32 M	220	DN32 PN 6	220/240 V	340	1,7	EEI ≤ 0,22	m.c.w.	20	25	24

The parameter of reference for the more efficient circulators is EEI ≤ 0,20.

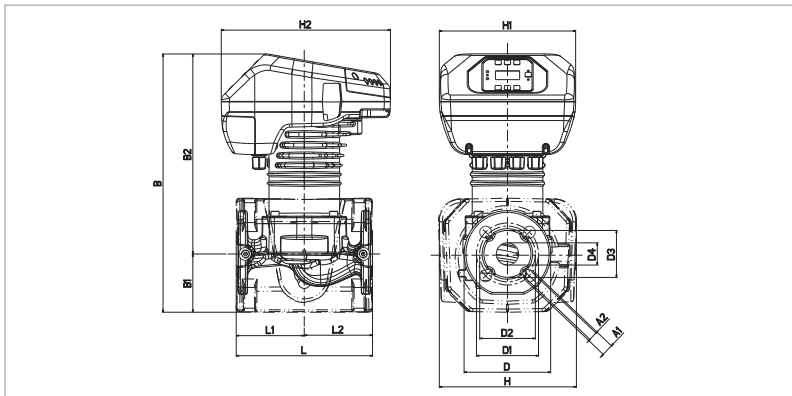

L	L1	L2	A1	A2	B	B1	B2
220	110	110	19	14	417	94	323

D	D1	D2	D3	D4	H	H1	H2
140	100	90	76	36	222	220	273

EVOPLUS - WET ROTOR ELECTRONIC CIRCULATORS

Pumped liquid temperature range: from -10 °C to +110 °C - Maximum operating pressure: 16 bar (1600 kPa)

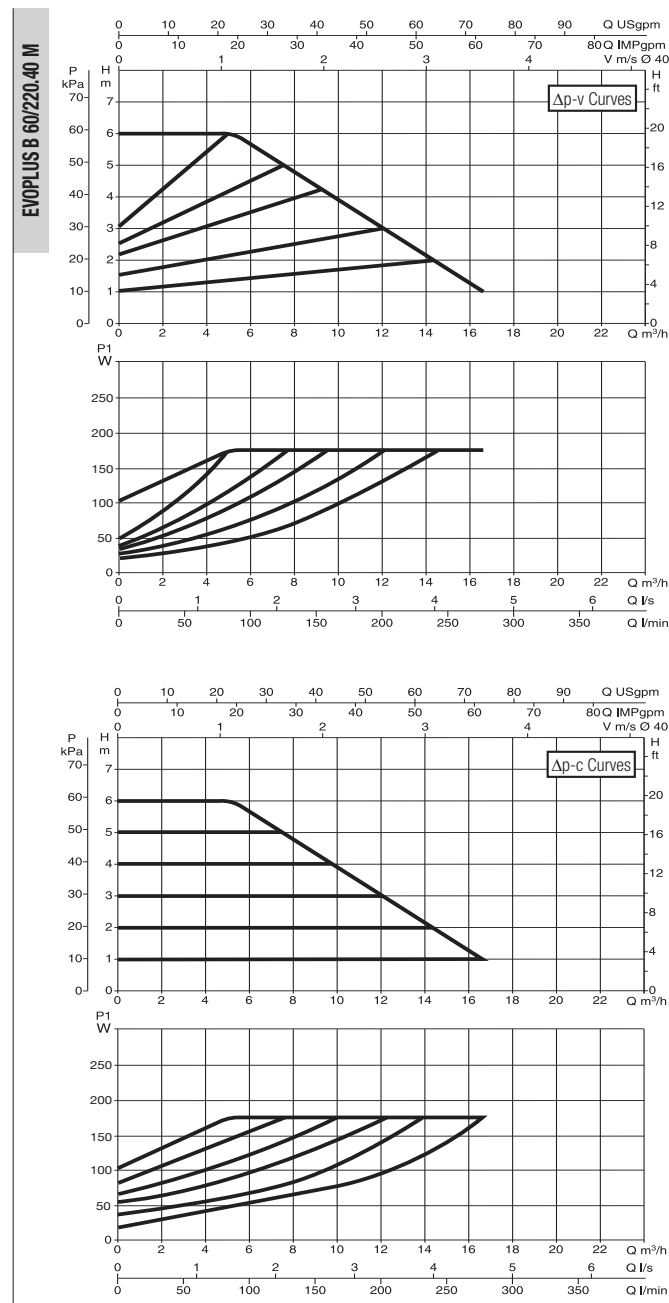
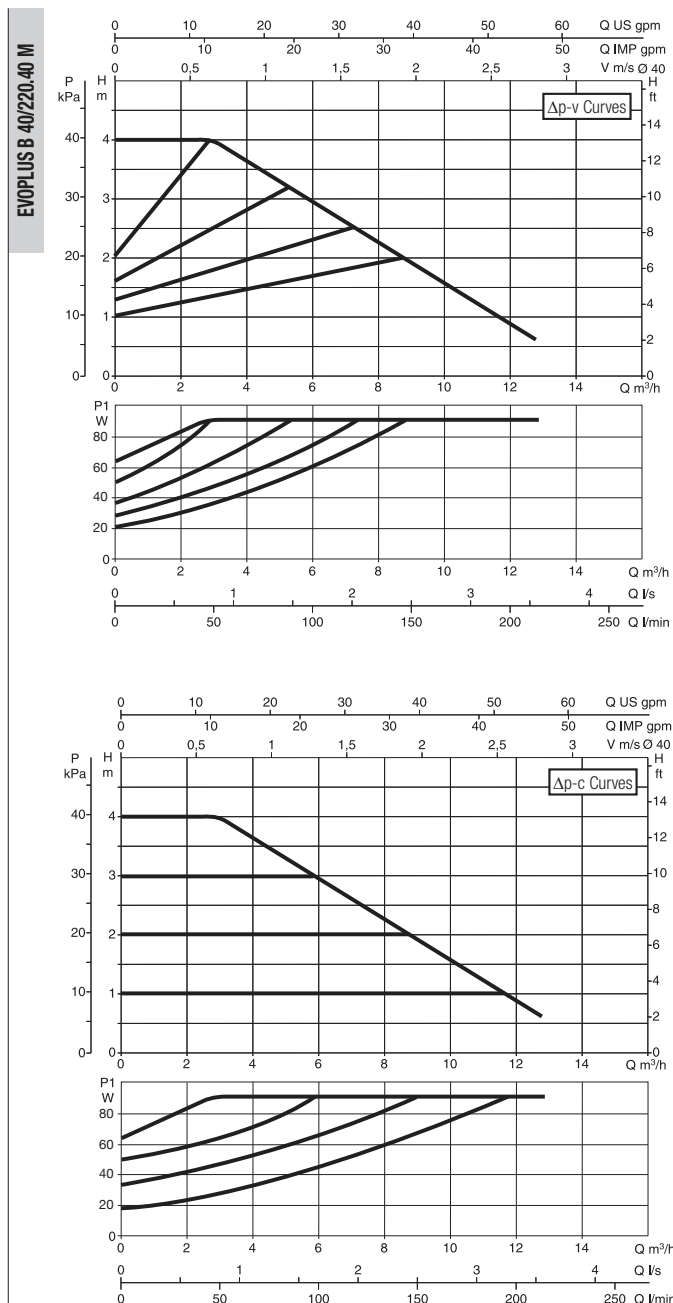

The curves are based on kinematic viscosity values = 1 mm²/s and density equal to 1000 kg/m³. Curve tolerance according to ISO 9906. Fixed speed curves available on the DNA.

MODEL	CENTRE DISTANCE mm	COUNTERFLANGES ON REQUEST	POWER INPUT 50/60 Hz	P1 MAX W	In A	EEI *	MINIMUM SUCTION PRESSURE			WEIGHT Kg
							t°	90°	100°	
EVOPLUS B 40/220.40 M	220	DN40 PN 10	220/240 V	90	0,7	EEI ≤ 0,23	m.c.w.	20	25	20,8
EVOPLUS B 60/220.40 M	220	DN40 PN 10	220/240 V	175	1	EEI ≤ 0,23	m.c.w.	20	25	20,8

The parameter of reference for the more efficient circulators is EEI ≤ 0,20.

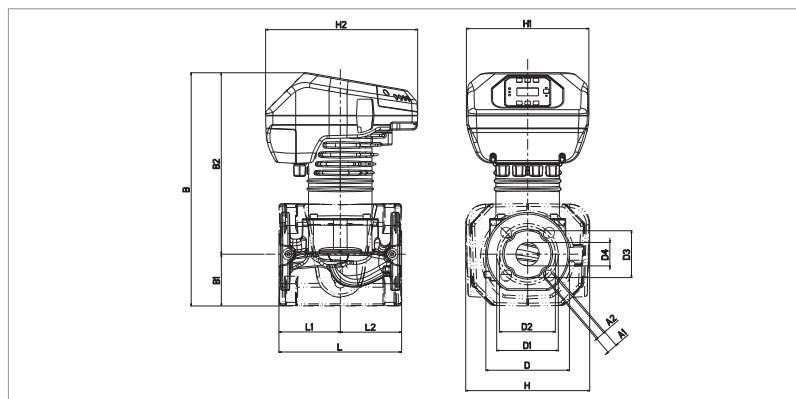

L	L1	L2	A1	A2	B	B1	B2
220	110	110	19	14	419	93	326

D	D1	D2	D3	D4	H	H1	H2
150	110	100	84	42	222	220	273

EVOPLUS - WET ROTOR ELECTRONIC CIRCULATORS

Pumped liquid temperature range: from -10 °C to +110 °C - Maximum operating pressure: 16 bar (1600 kPa)

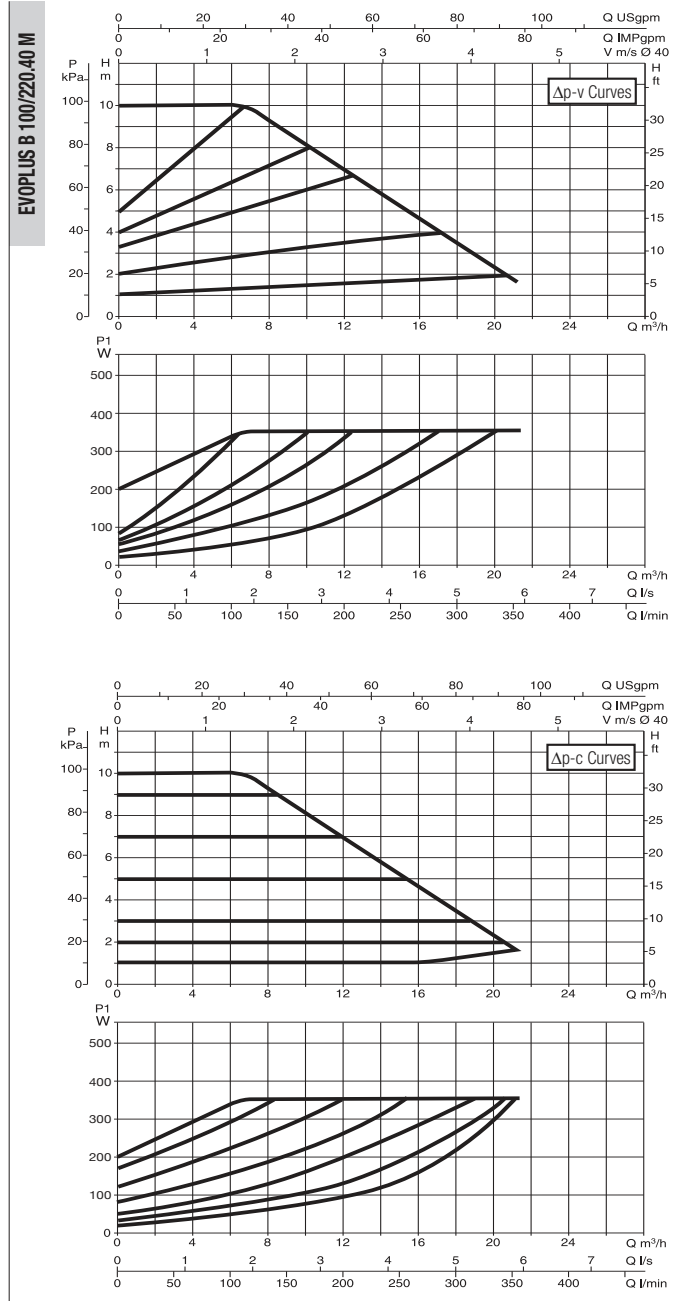
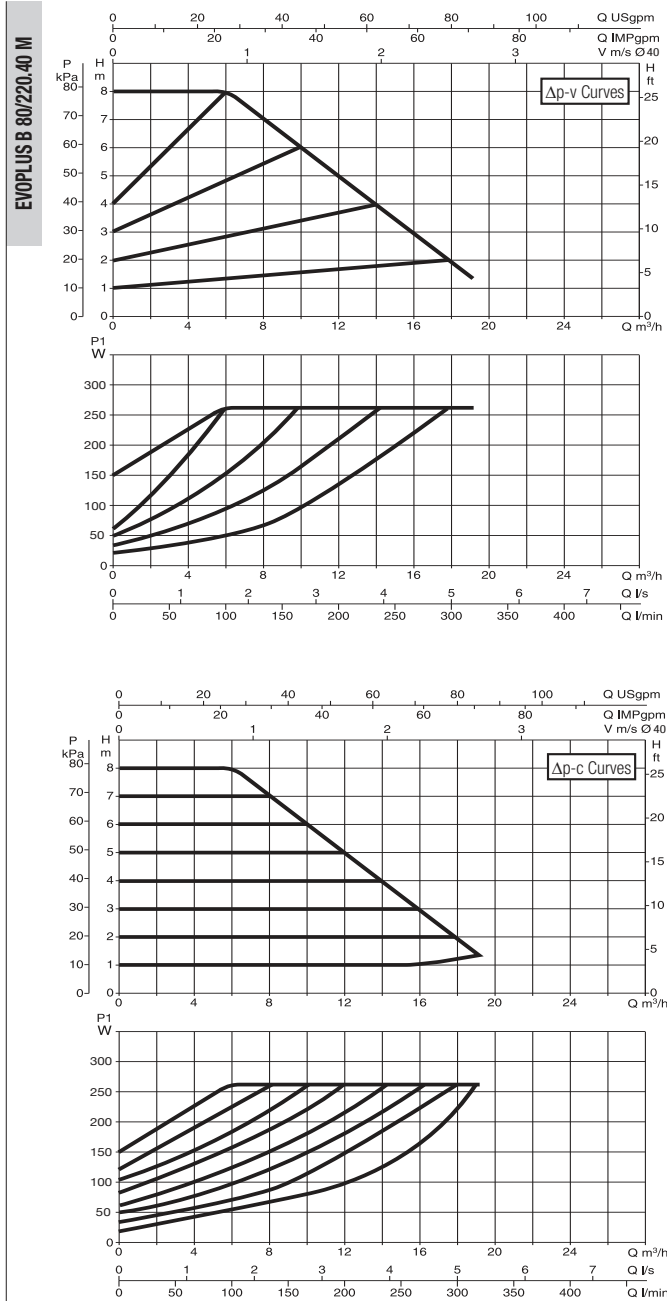

The curves are based on kinematic viscosity values = 1 mm²/s and density equal to 1000 kg/m³. Curve tolerance according to ISO 9906. Fixed speed curves available on the DNA.

MODEL	CENTRE DISTANCE mm	COUNTERFLANGES ON REQUEST	POWER INPUT 50/60 Hz	P1 MAX W	In A	EEI*	MINIMUM SUCTION PRESSURE			WEIGHT Kg
							t°	90°	100°	
EVOPLUS B 80/220.40 M	220	DN40 PN 10	220/240 V	260	1,35	EEI ≤ 0,21	m.c.w.	20	25	20,8
EVOPLUS B 100/220.40 M	220	DN40 PN 10	220/240 V	350	1,75	EEI ≤ 0,20	m.c.w.	20	25	20,8

The parameter of reference for the more efficient circulators is EEI ≤ 0,20.

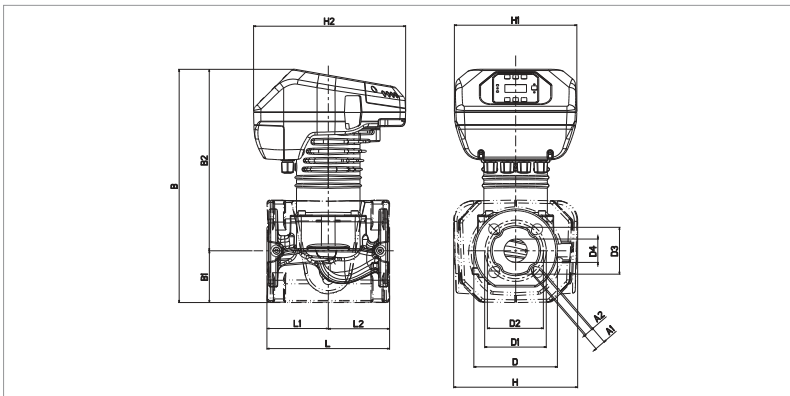

L	L1	L2	A1	A2	B	B1	B2
220	110	110	19	14	419	93	326

D	D1	D2	D3	D4	H	H1	H2
150	110	100	84	42	222	220	273

EVOPLUS - WET ROTOR ELECTRONIC CIRCULATORS

Pumped liquid temperature range: from -10 °C to +110 °C - Maximum operating pressure: 16 bar (1600 kPa)

EVOPLUS B 120/250.40 M

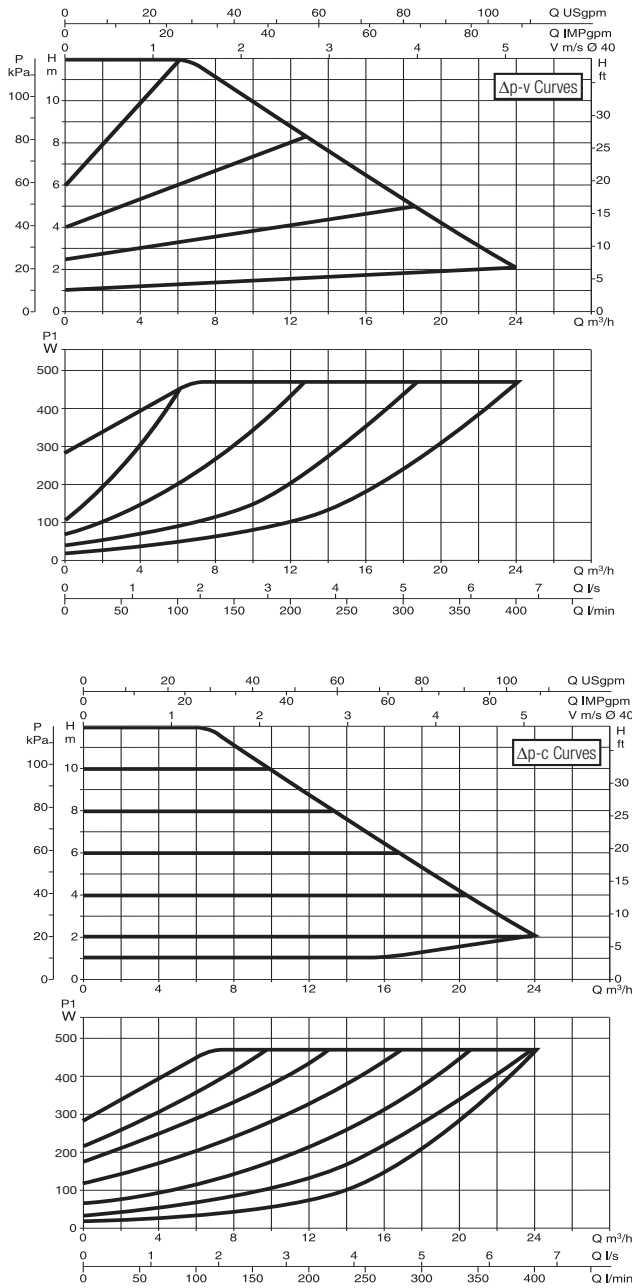

EVOPLUS B 150/250.40 M

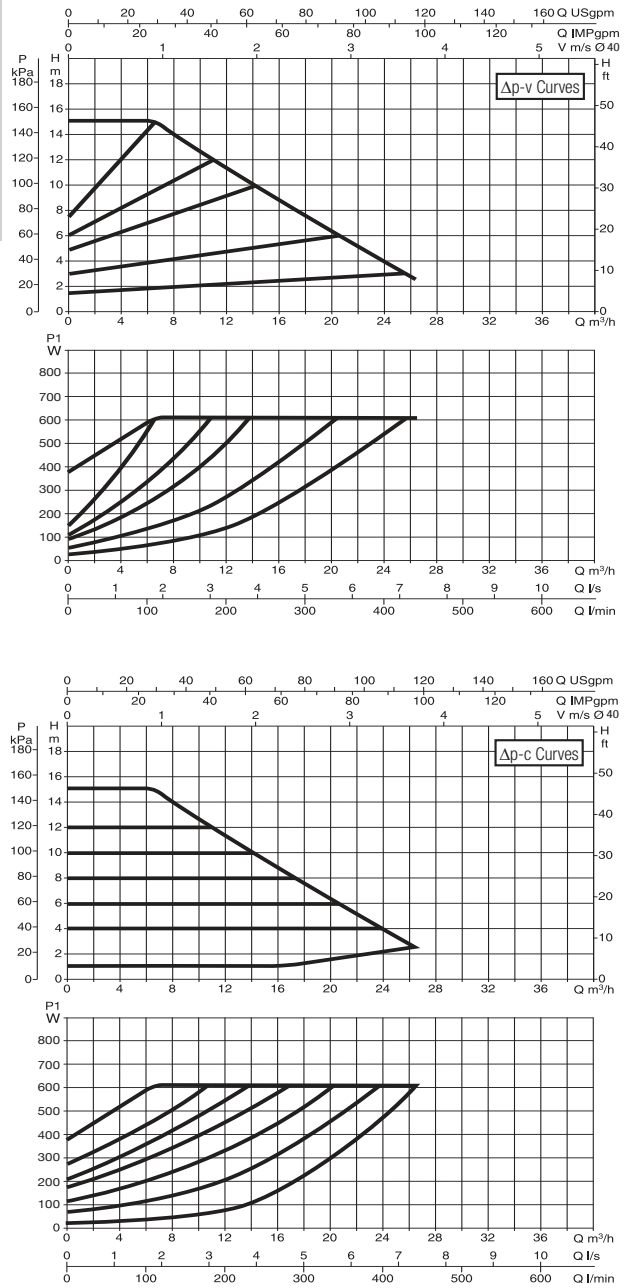

The curves are based on kinematic viscosity values = 1 mm²/s and density equal to 1000 kg/m³. Curve tolerance according to ISO 9906. Fixed speed curves available on the DNA.

MODEL	CENTRE DISTANCE mm	COUNTERFLANGES ON REQUEST	POWER INPUT 50/60 Hz	P1 MAX W	In A	EEI*	MINIMUM SUCTION PRESSURE			WEIGHT Kg
							t°	90°	100°	
EVOPLUS B 120/250.40 M	250	DN40 PN 10	220/240 V	465	2,2	EEI ≤ 0,20	m.c.w.	20	25	20
EVOPLUS B 150/250.40 M	250	DN40 PN 10	220/240 V	610	2,9	EEI ≤ 0,20	m.c.w.	20	25	20

The parameter of reference for the more efficient circulators is EEI ≤ 0,20.

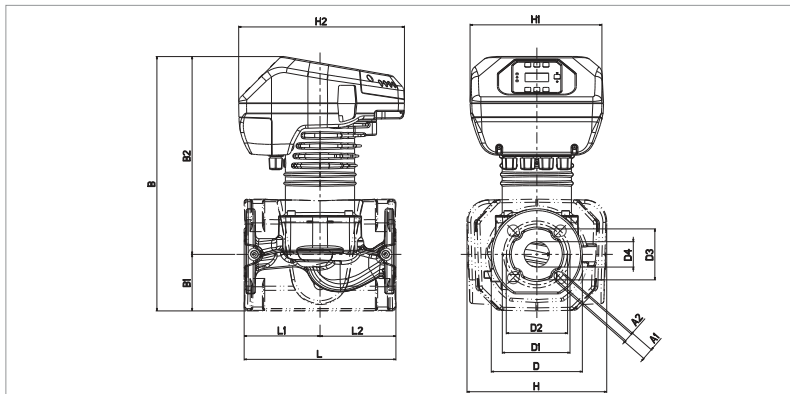

L	L1	L2	A1	A2	B	B1	B2
250	125	125	19	14	419	93	326

D	D1	D2	D3	D4	H	H1	H2
150	110	100	84	42	230	220	273

EVOPLUS - WET ROTOR ELECTRONIC CIRCULATORS

Pumped liquid temperature range: from -10 °C to +110 °C - Maximum operating pressure: 16 bar (1600 kPa)

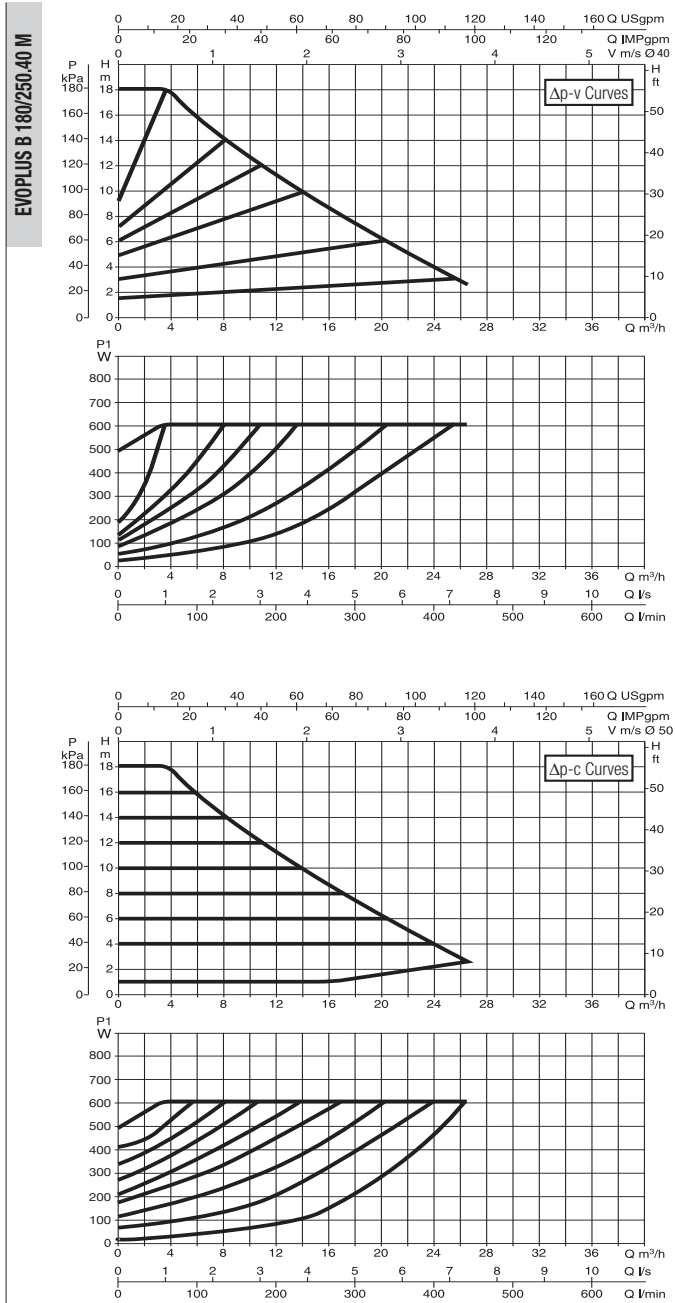

The curves are based on kinematic viscosity values = 1 mm²/s and density equal to 1000 kg/m³. Curve tolerance according to ISO 9906. Fixed speed curves available on the DNA.

MODEL	CENTRE DISTANCE mm	COUNTERFLANGES ON REQUEST	POWER INPUT 50/60 Hz	P1 MAX W	In A	EEI*	MINIMUM SUCTION PRESSURE			WEIGHT Kg
							t°	90°	100°	
EVOPLUS B 180/250.40 M	250	DN40 PN 10	220/240 V	610	2,9	EEI ≤ 0,20	m.c.w.	20	25	20

The parameter of reference for the more efficient circulators is EEI ≤ 0,20.

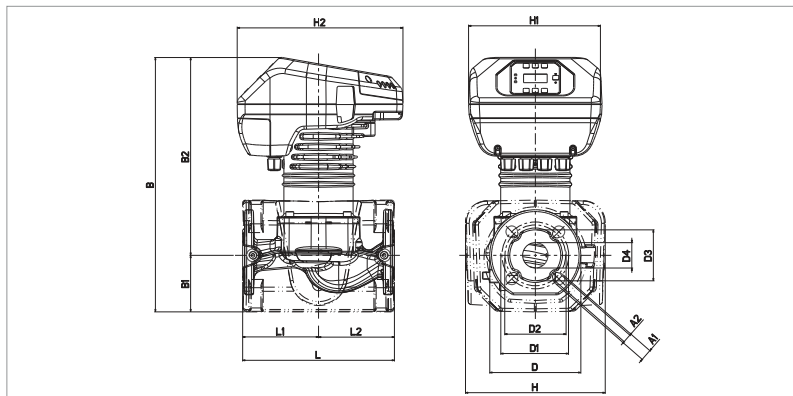

L	L1	L2	A1	A2	B	B1	B2
250	125	125	19	14	419	93	326

D	D1	D2	D3	D4	H	H1	H2
150	110	100	84	42	230	220	273

EVOPLUS - WET ROTOR ELECTRONIC CIRCULATORS

Pumped liquid temperature range: from -10 °C to +110 °C - Maximum operating pressure: 16 bar (1600 kPa)

EVOPLUS B 40/240.50 M

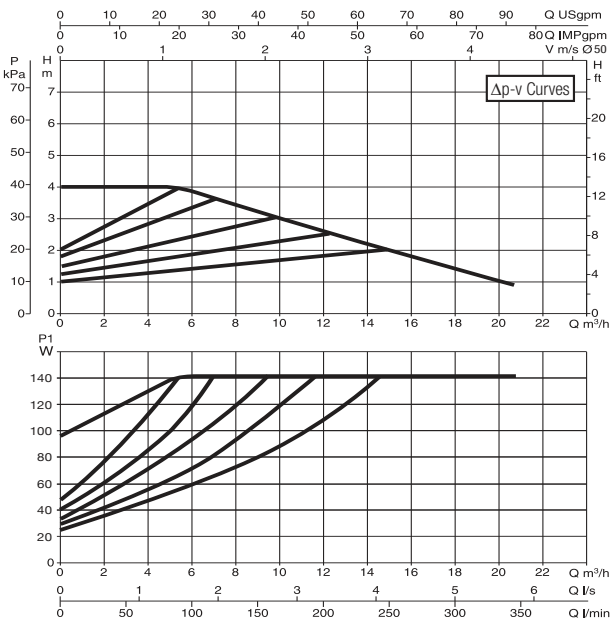

EVOPLUS B 60/240.50 M

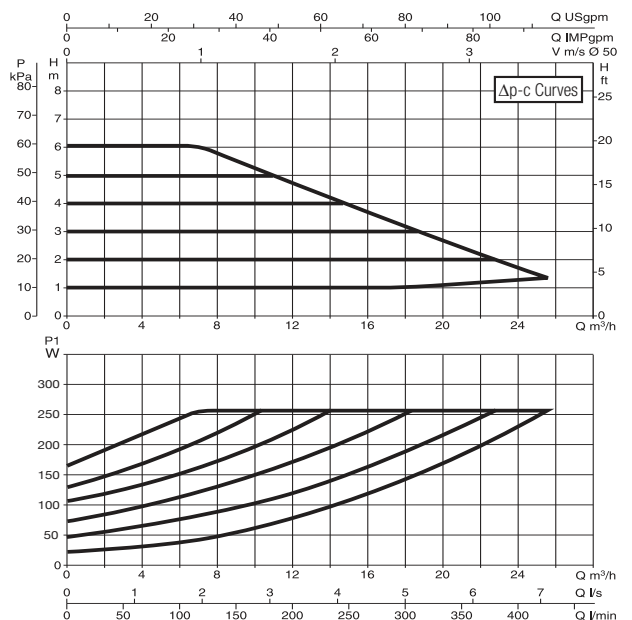
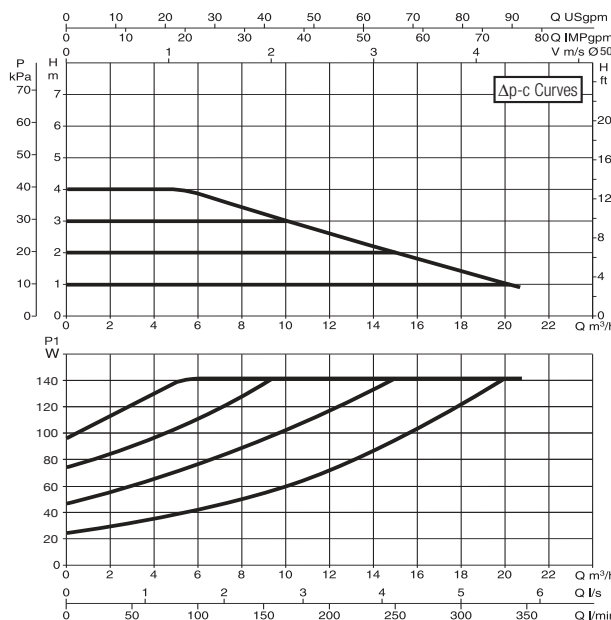
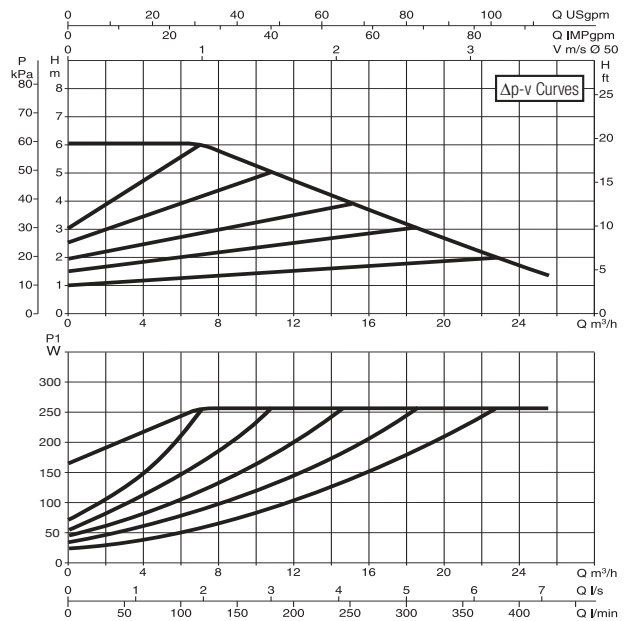

The curves are based on kinematic viscosity values = 1 mm²/s and density equal to 1000 kg/m³. Curve tolerance according to ISO 9906. Fixed speed curves available on the DNA.

MODEL	CENTRE DISTANCE mm	COUNTERFLANGES ON REQUEST	POWER INPUT 50/60 Hz	P1 MAX W	In A	EEI*	MINIMUM SUCTION PRESSURE			WEIGHT Kg
							t°	90°	100°	
EVOPLUS B 40/240.50 M	240	DN50 PN 10	220/240 V	140	0,87	EEI ≤ 0,23	m.c.w.	20	25	21,4
EVOPLUS B 60/240.50 M	240	DN50 PN 10	220/240 V	260	1,35	EEI ≤ 0,21	m.c.w.	20	25	21,4

*The parameter of reference for the more efficient circulators is EEI ≤ 0,20.

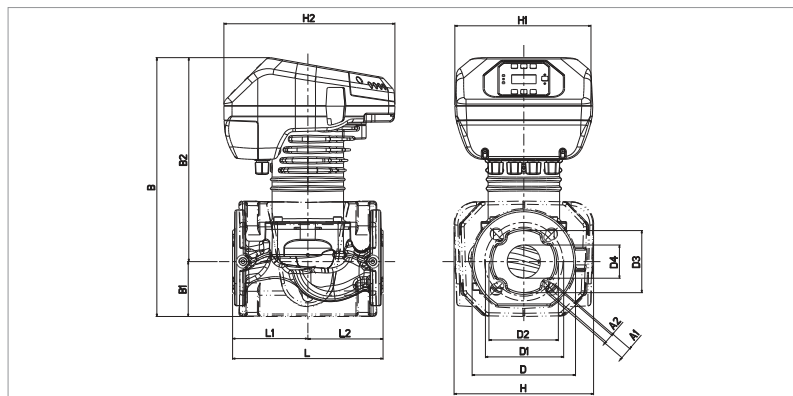

L	L1	L2	A1	A2	B	B1	B2
240	120	120	19	14	413	87	325

D	D1	D2	D3	D4	H	H1	H2
165	125	110	99	53	222	220	273

EVOPLUS - WET ROTOR ELECTRONIC CIRCULATORS

Pumped liquid temperature range: from -10 °C to +110 °C - Maximum operating pressure: 16 bar (1600 kPa)

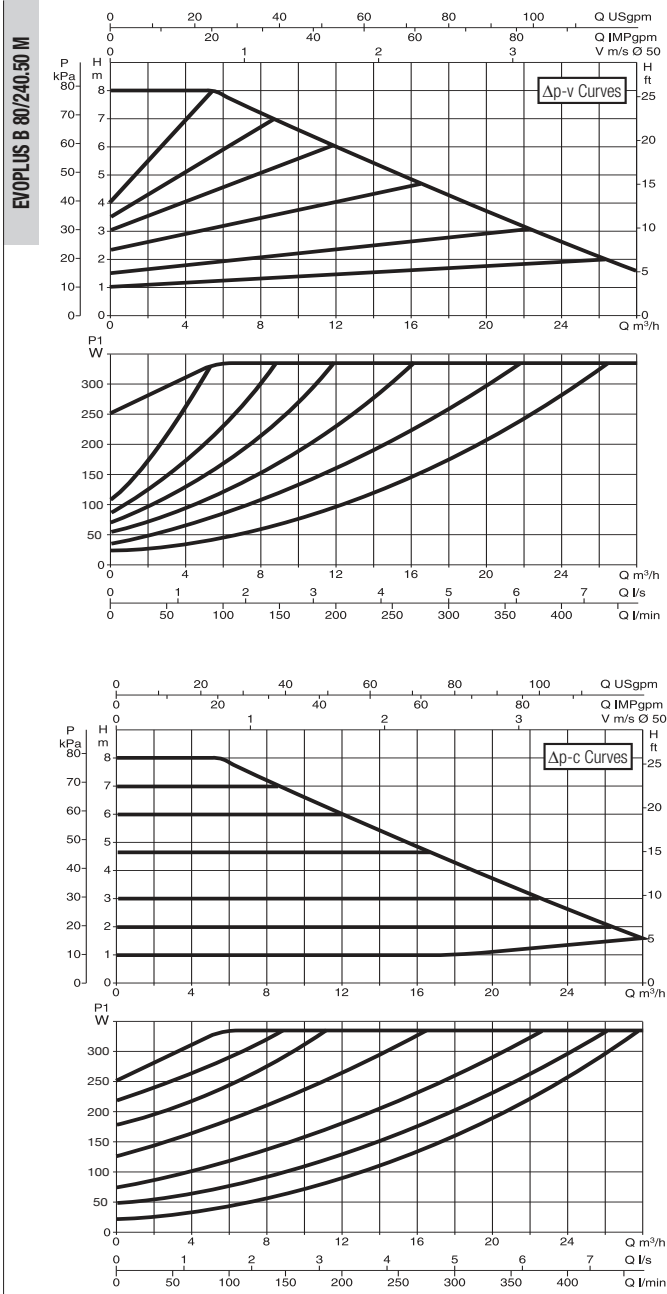

The curves are based on kinematic viscosity values = 1 mm²/s and density equal to 1000 kg/m³. Curve tolerance according to ISO 9906. Fixed speed curves available on the DNA.

MODEL	CENTRE DISTANCE mm	COUNTERFLANGES ON REQUEST	POWER INPUT 50/60 Hz	P1 MAX W	In A	EEI*	MINIMUM SUCTION PRESSURE			WEIGHT Kg
							t°	90°	100°	
EVOPLUS B 80/240.50 M	240	DN50 PN 10	220/240 V	330	0,87	EEI ≤ 0,21	m.c.w.	20	25	21,4

*The parameter of reference for the more efficient circulators is EEI ≤ 0,20.

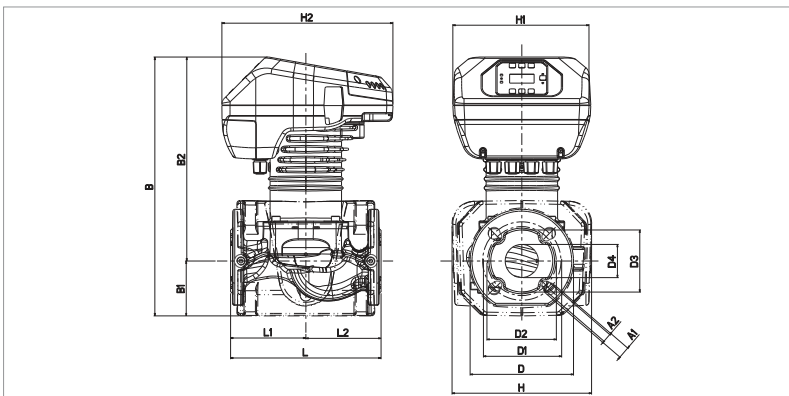

L	L1	L2	A1	A2	B	B1	B2
240	120	120	19	14	413	87	325

D	D1	D2	D3	D4	H	H1	H2
165	125	110	99	53	222	220	273

EVOPLUS - WET ROTOR ELECTRONIC CIRCULATORS

Pumped liquid temperature range: from -10 °C to +110 °C - Maximum operating pressure: 16 bar (1600 kPa)

EVOPLUS B 100/280.50 M

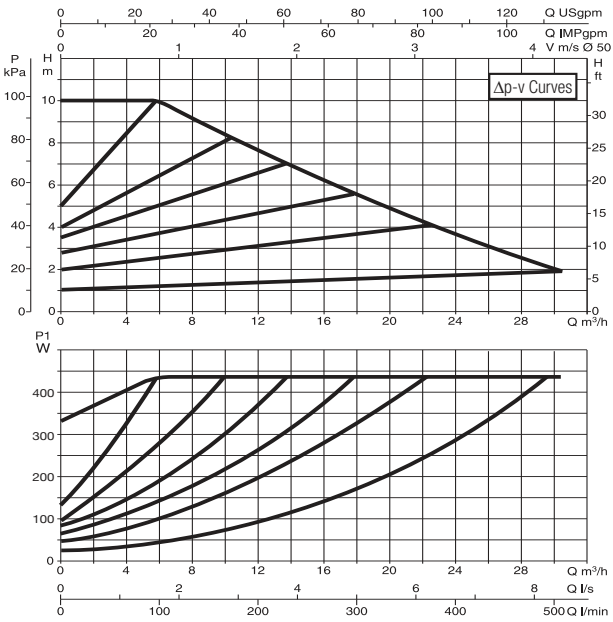

EVOPLUS B 120/280.50 M

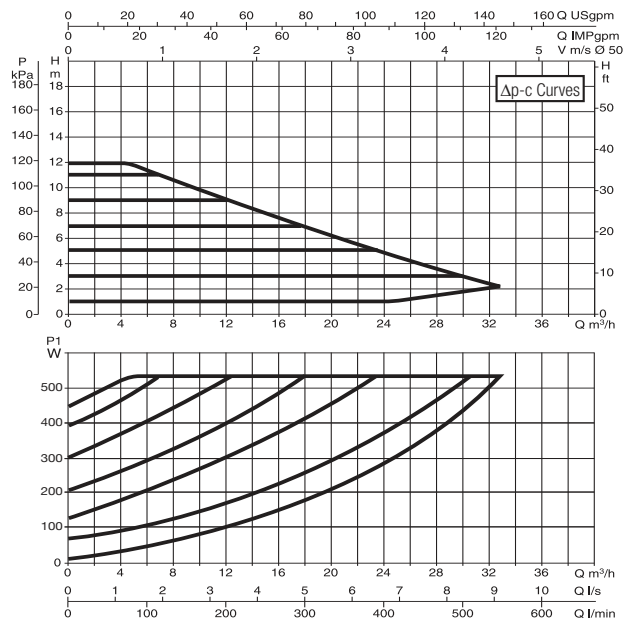
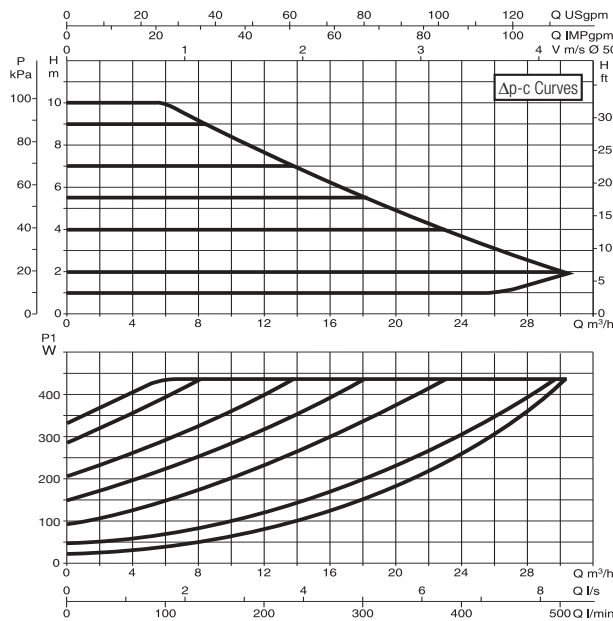
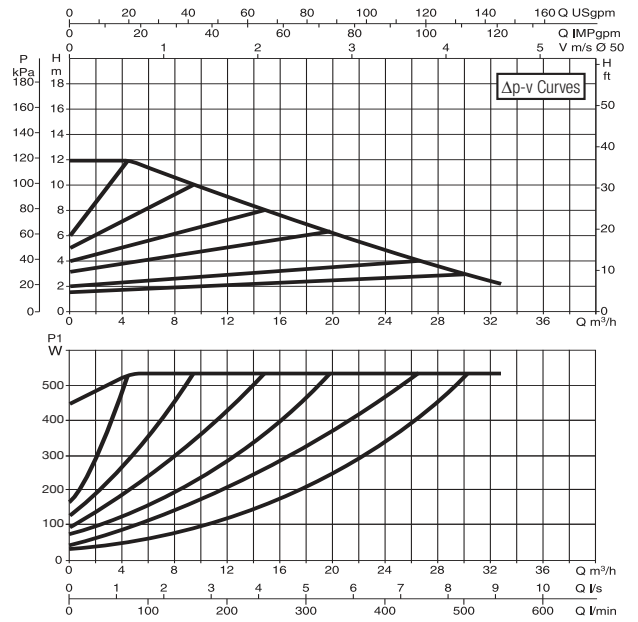

The curves are based on kinematic viscosity values = 1 mm²/s and density equal to 1000 kg/m³. Curve tolerance according to ISO 9906. Fixed speed curves available on the DNA.

MODEL	CENTRE DISTANCE mm	COUNTERFLANGES ON REQUEST	POWER INPUT 50/60 Hz	P1 MAX W	In A	EEI*	MINIMUM SUCTION PRESSURE			WEIGHT Kg
							t°	90°	100°	
EVOPLUS B 100/280.50 M	280	DN50 PN 10	220/240 V	430	2,1	EEI ≤ 0,20	m.c.w.	20	25	22
EVOPLUS B 120/280.50 M	280	DN50 PN 10	220/240 V	530	2,5	EEI ≤ 0,19	m.c.w.	20	25	21,8

* The parameter of reference for the more efficient circulators is EEI ≤ 0,20.

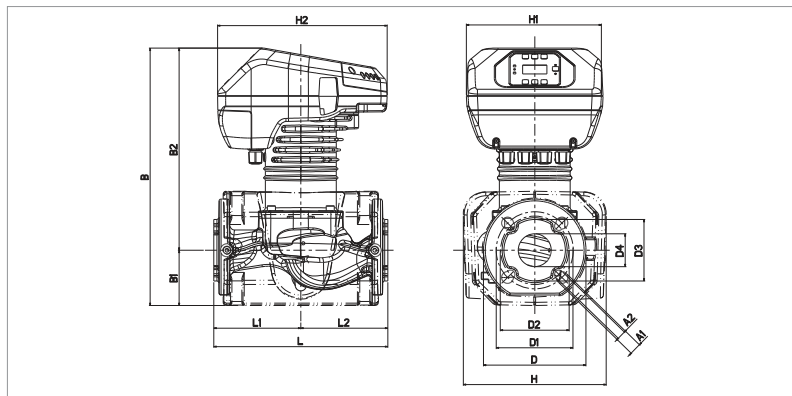

L	L1	L2	A1	A2	B	B1	B2
280	140	140	19	14	413	87	325

D	D1	D2	D3	D4	H	H1	H2
165	125	110	99	53	230	220	273

EVOPLUS - WET ROTOR ELECTRONIC CIRCULATORS

Pumped liquid temperature range: from -10 °C to +110 °C - Maximum operating pressure: 16 bar (1600 kPa)

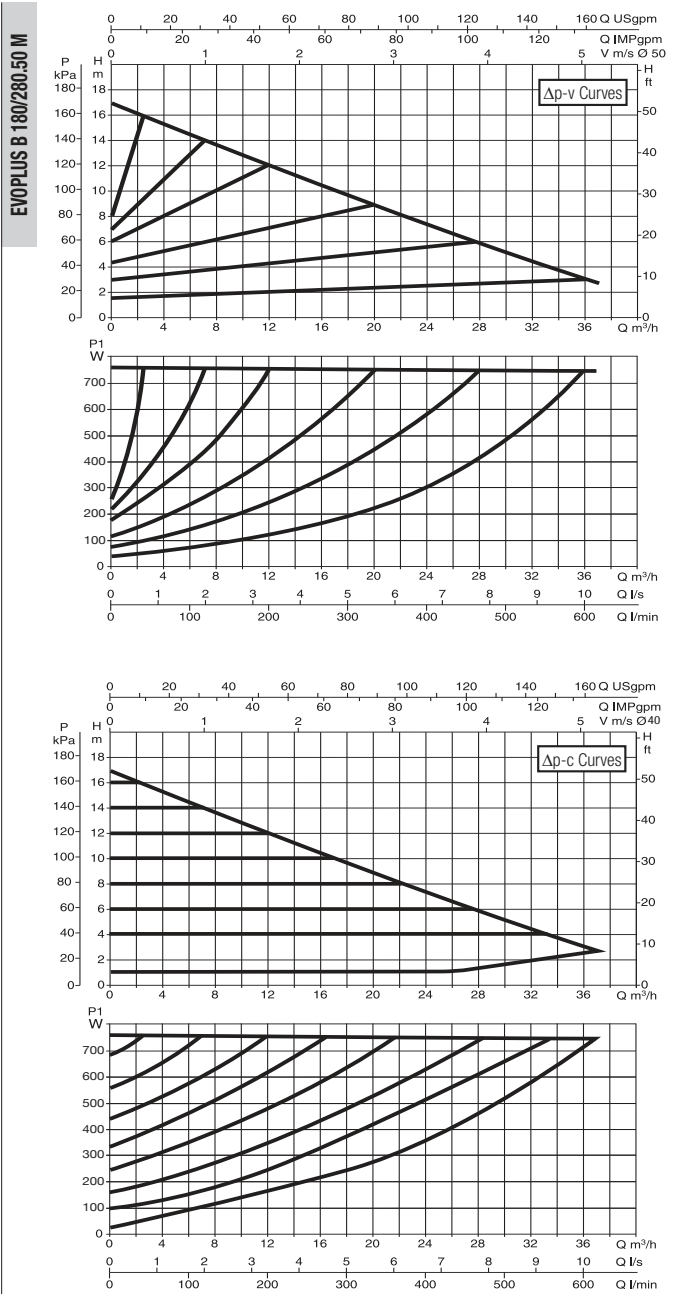
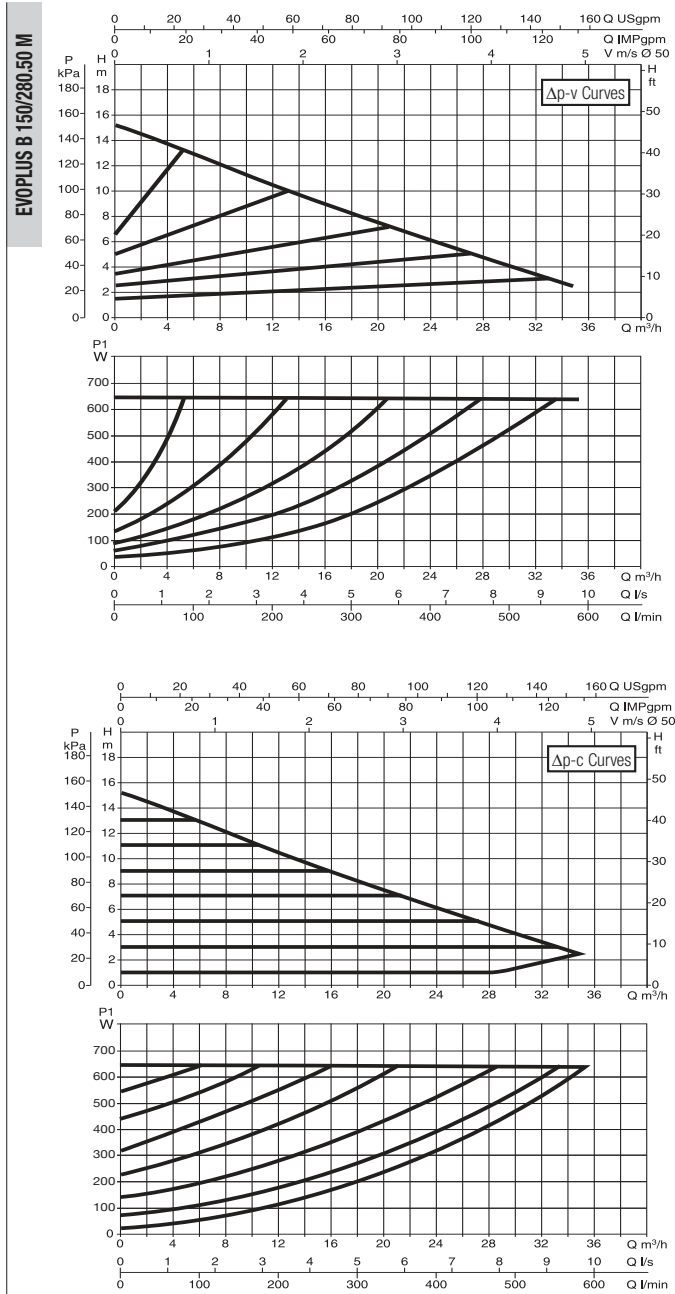

The curves are based on kinematic viscosity values = 1 mm²/s and density equal to 1000 kg/m³. Curve tolerance according to ISO 9906. Fixed speed curves available on the DNA.

MODEL	CENTRE DISTANCE mm	COUNTERFLANGES ON REQUEST	POWER INPUT 50/60 Hz	P1 MAX W	In A	EEI*	MINIMUM SUCTION PRESSURE			WEIGHT Kg
							t°	90°	100°	
EVOPLUS B 150/280.50 M	280	DN50 PN 10	220/240 V	640	3	EEI ≤ 0,19	m.c.w.	20	25	22,8
EVOPLUS B 180/280.50 M	280	DN50 PN 10	220/240 V	750	3,45	EEI ≤ 0,19	m.c.w.	20	25	22,8

* The parameter of reference for the more efficient circulators is EEI ≤ 0,20.

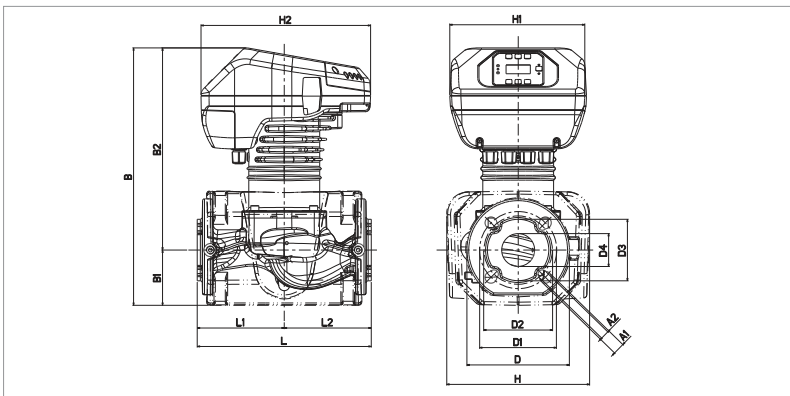

L	L1	L2	A1	A2	B	B1	B2
280	140	140	19	14	413	87	325

D	D1	D2	D3	D4	H	H1	H2
165	125	110	99	53	230	220	273

EVOPLUS - WET ROTOR ELECTRONIC CIRCULATORS

Pumped liquid temperature range: from -10 °C to +110 °C - Maximum operating pressure: 16 bar (1600 kPa)

EVOPLUS B 40/340.65 M

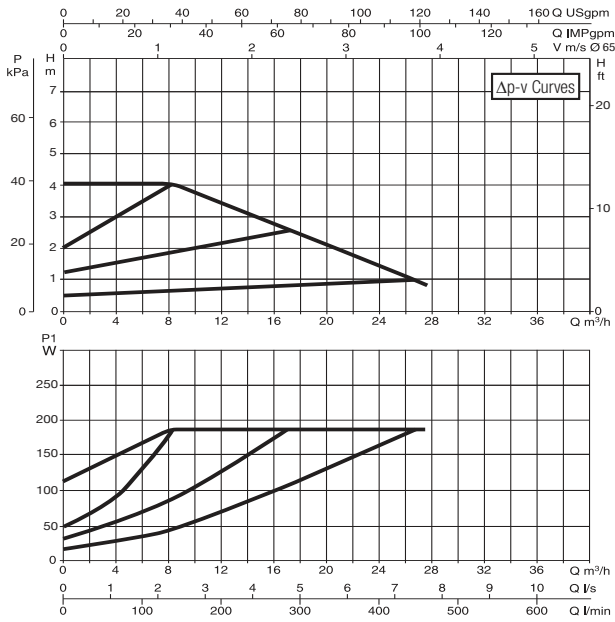

EVOPLUS B 60/340.65 M

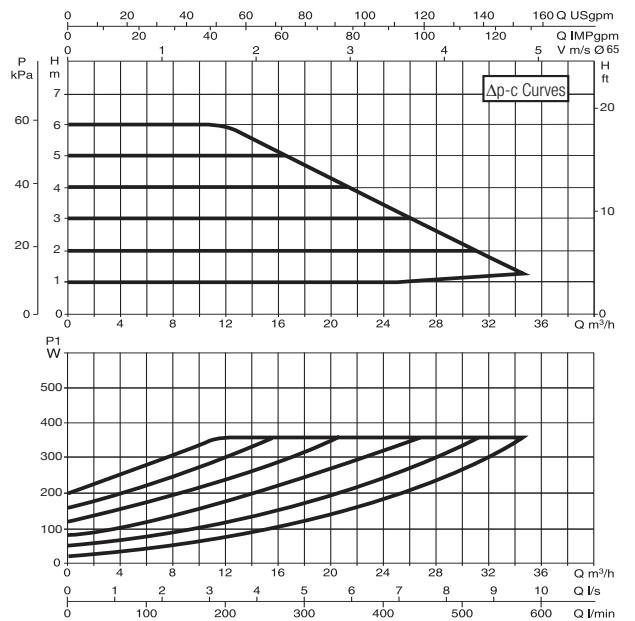
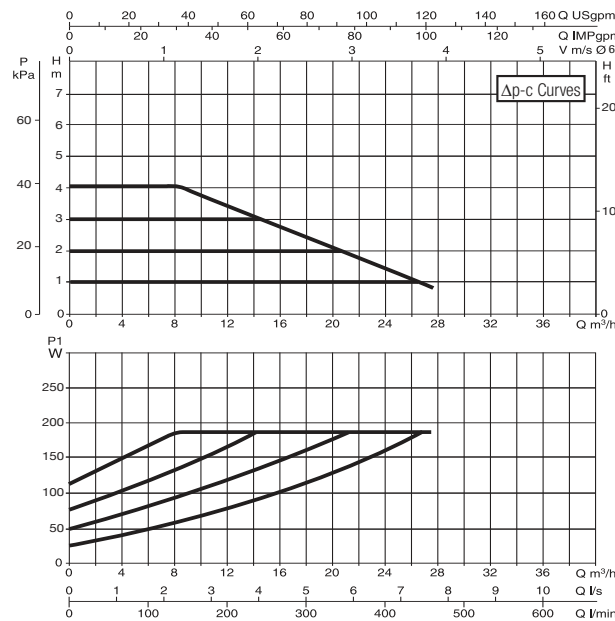
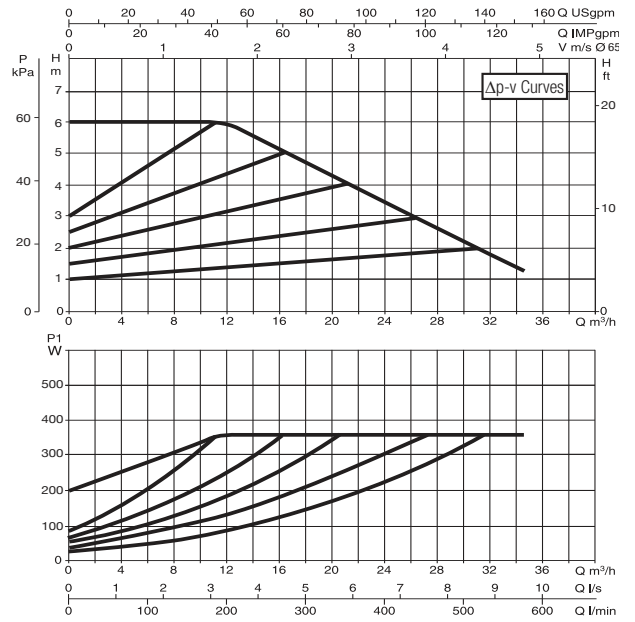

The curves are based on kinematic viscosity values = 1 mm²/s and density equal to 1000 kg/m³. Curve tolerance according to ISO 9906. Fixed speed curves available on the DNA.

MODEL	CENTRE DISTANCE mm	COUNTERFLANGES ON REQUEST	POWER INPUT 50/60 Hz	P1 MAX W	In A	EEI*	MINIMUM SUCTION PRESSURE			WEIGHT Kg
							t°	90°	100°	
EVOPLUS B 40/340.65 M	340	DN65 PN 10	220/240 V	190	1,1	EEI ≤ 0,21	m.c.w.	20	25	23,8
EVOPLUS B 60/340.65 M	340	DN65 PN 10	220/240 V	355	1,8	EEI ≤ 0,20	m.c.w.	20	25	23,8

* The parameter of reference for the more efficient circulators is EEI ≤ 0,20.

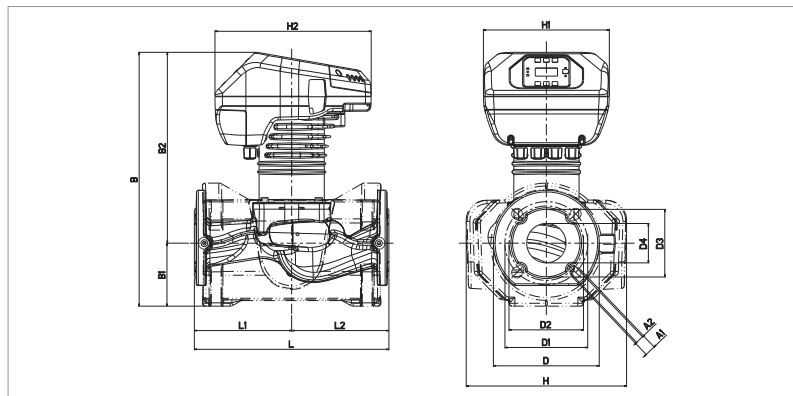

L	L1	L2	A1	A2	B	B1	B2
340	170	170	19	14	443	110	333

D	D1	D2	D3	D4	H	H1	H2
185	145	130	118	69	280	220	273

EVOPLUS - WET ROTOR ELECTRONIC CIRCULATORS

Pumped liquid temperature range: from -10 °C to +110 °C - Maximum operating pressure: 16 bar (1600 kPa)

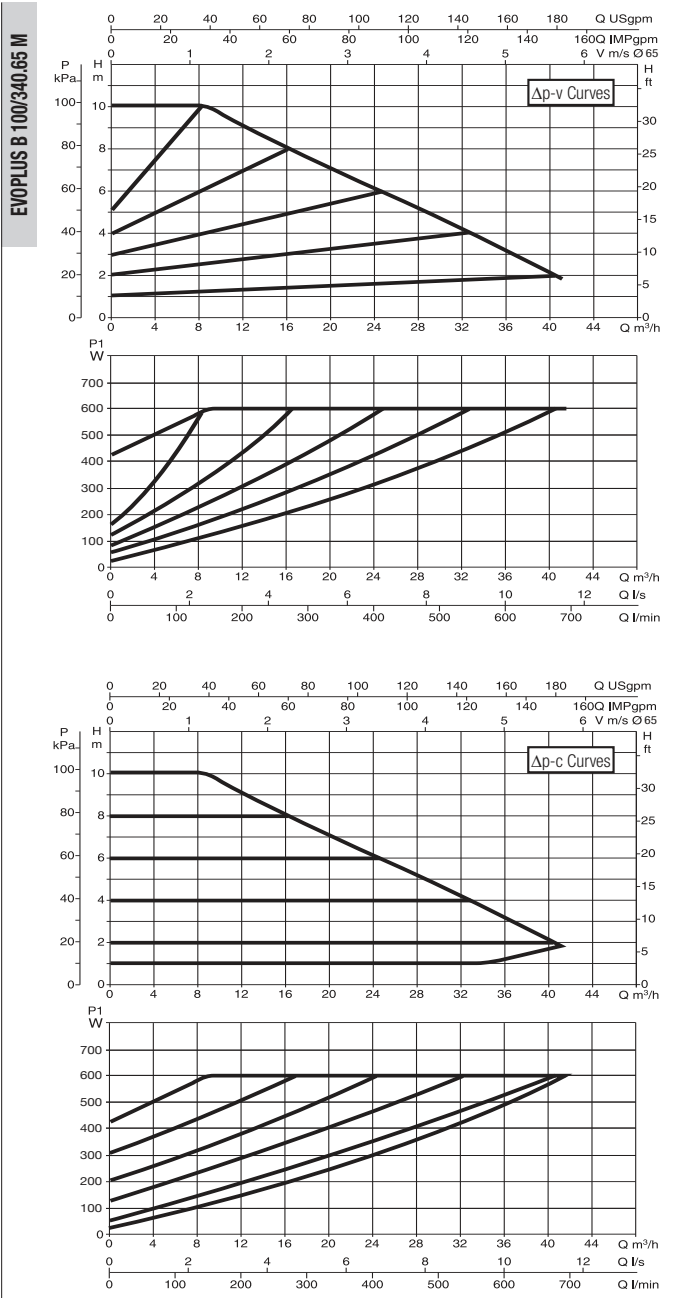
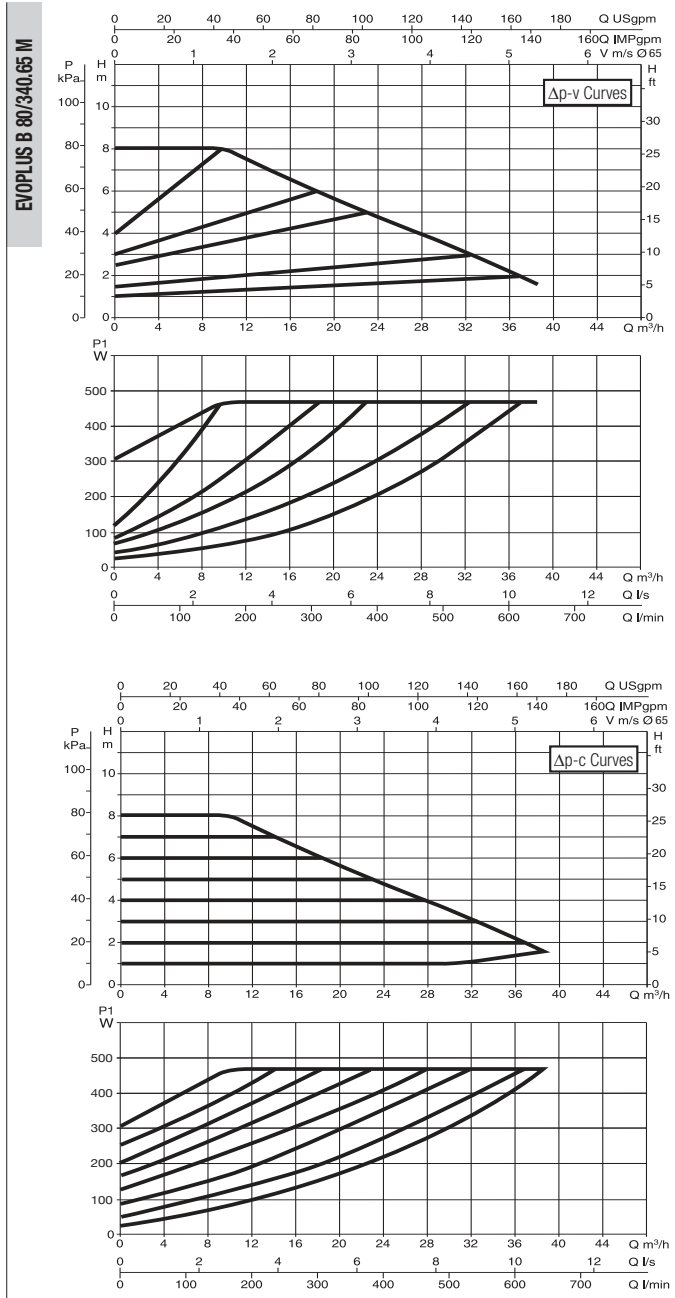

The curves are based on kinematic viscosity values = 1 mm²/s and density equal to 1000 kg/m³. Curve tolerance according to ISO 9906. Fixed speed curves available on the DNA.

MODEL	CENTRE DISTANCE mm	COUNTERFLANGES ON REQUEST	POWER INPUT 50/60 Hz	P1 MAX W	In A	EEI*	MINIMUM SUCTION PRESSURE			WEIGHT Kg
							t°	90°	100°	
EVOPLUS B 80/340.65 M	340	DN65 PN 10	220/240 V	465	2,2	EEI ≤ 0,19	m.c.w.	20	25	24,6
EVOPLUS B 100/340.65 M	340	DN65 PN 10	220/240 V	590	2,8	EEI ≤ 0,18	m.c.w.	20	25	25

* The parameter of reference for the more efficient circulators is EEI ≤ 0,20.

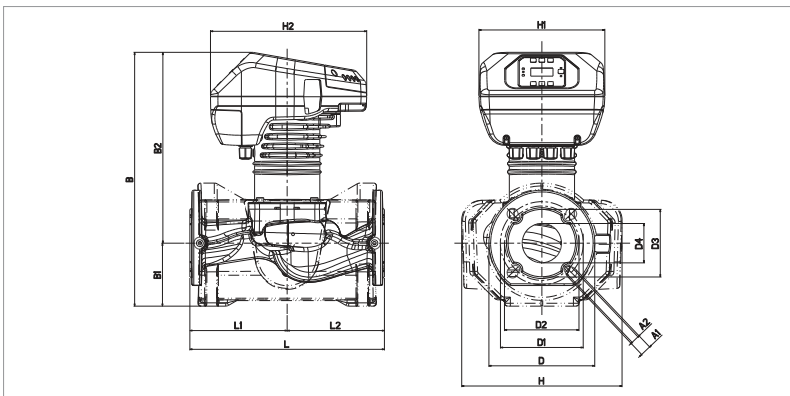

L	L1	L2	A1	A2	B	B1	B2
340	170	170	19	14	443	110	333

D	D1	D2	D3	D4	H	H1	H2
185	145	130	118	69	280	220	273

EVOPLUS - WET ROTOR ELECTRONIC CIRCULATORS

Pumped liquid temperature range: from -10 °C to +110 °C - Maximum operating pressure: 16 bar (1600 kPa)

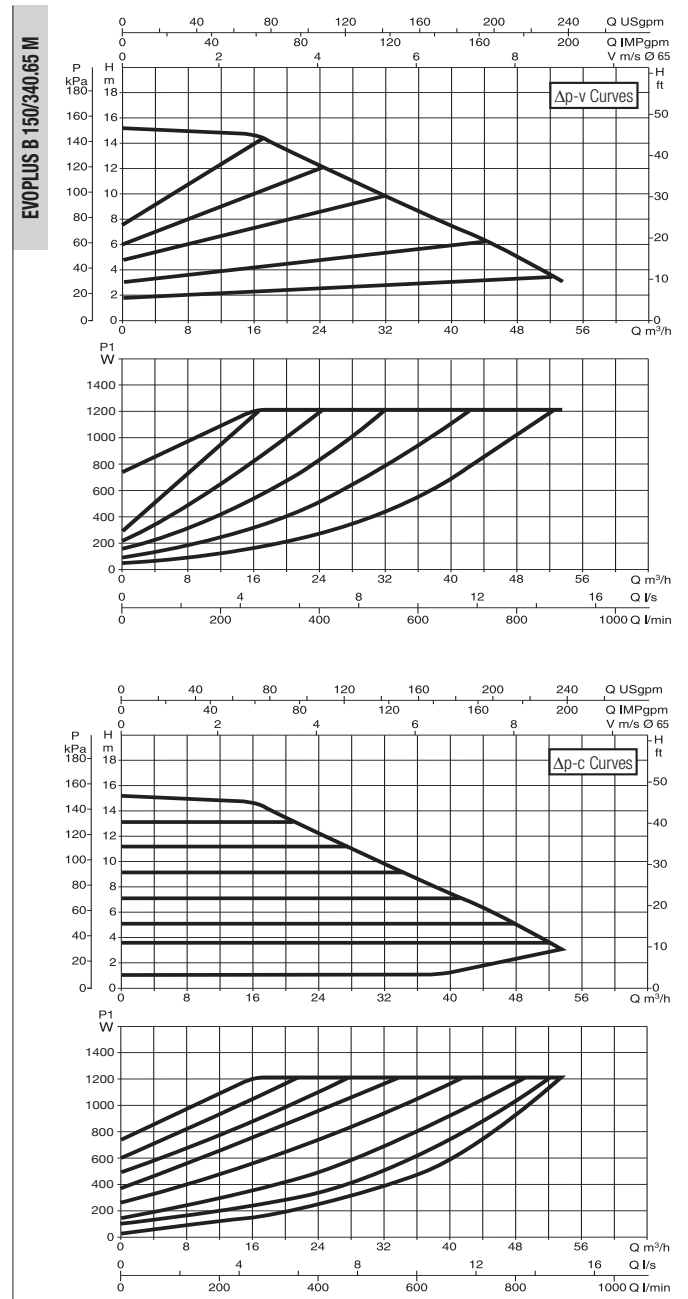
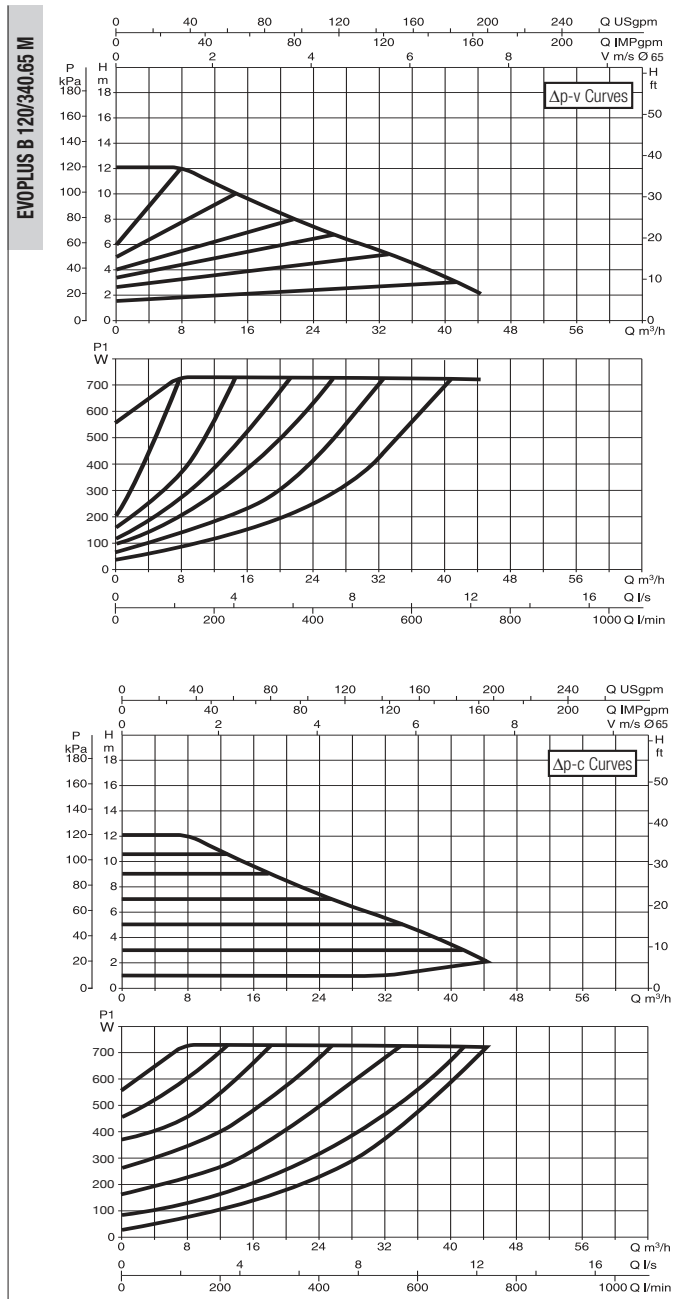

The curves are based on kinematic viscosity values = 1 mm²/s and density equal to 1000 kg/m³. Curve tolerance according to ISO 9906. Fixed speed curves available on the DNA.

MODEL	CENTRE DISTANCE mm	COUNTERFLANGES ON REQUEST	POWER INPUT 50/60 Hz	P1 MAX W	In A	EEI*	MINIMUM SUCTION PRESSURE			WEIGHT Kg
							t°	90°	100°	
EVOPLUS B 120/340.65 M	340	DN65 PN 10	220/240 V	730	3,45	EEI ≤ 0,18	m.c.w.	20	25	24,6
EVOPLUS B 150/340.65 M	340	DN65 PN 10	220/240 V	1210	5,5	EEI ≤ 0,18	m.c.w.	20	25	27

* The parameter of reference for the more efficient circulators is EEI ≤ 0,20.

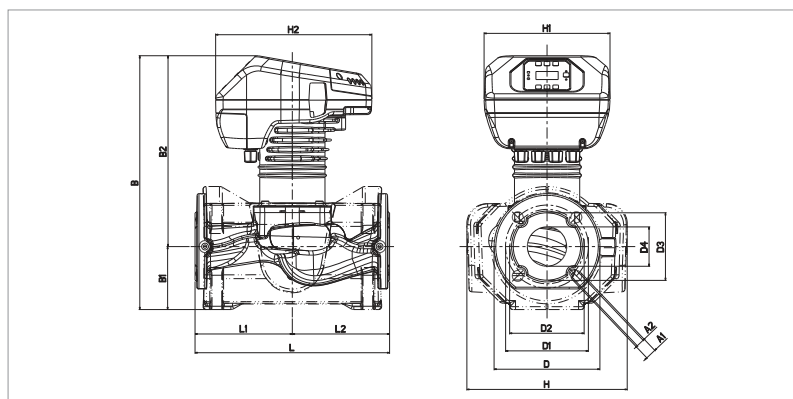

L	L1	L2	A1	A2	B	B1	B2
340	170	170	19	14	443	110	333

D	D1	D2	D3	D4	H	H1	H2
185	145	130	118	69	280	220	273

EVOPLUS - WET ROTOR ELECTRONIC CIRCULATORS

Pumped liquid temperature range: from -10 °C to +110 °C - Maximum operating pressure: 16 bar (1600 kPa)

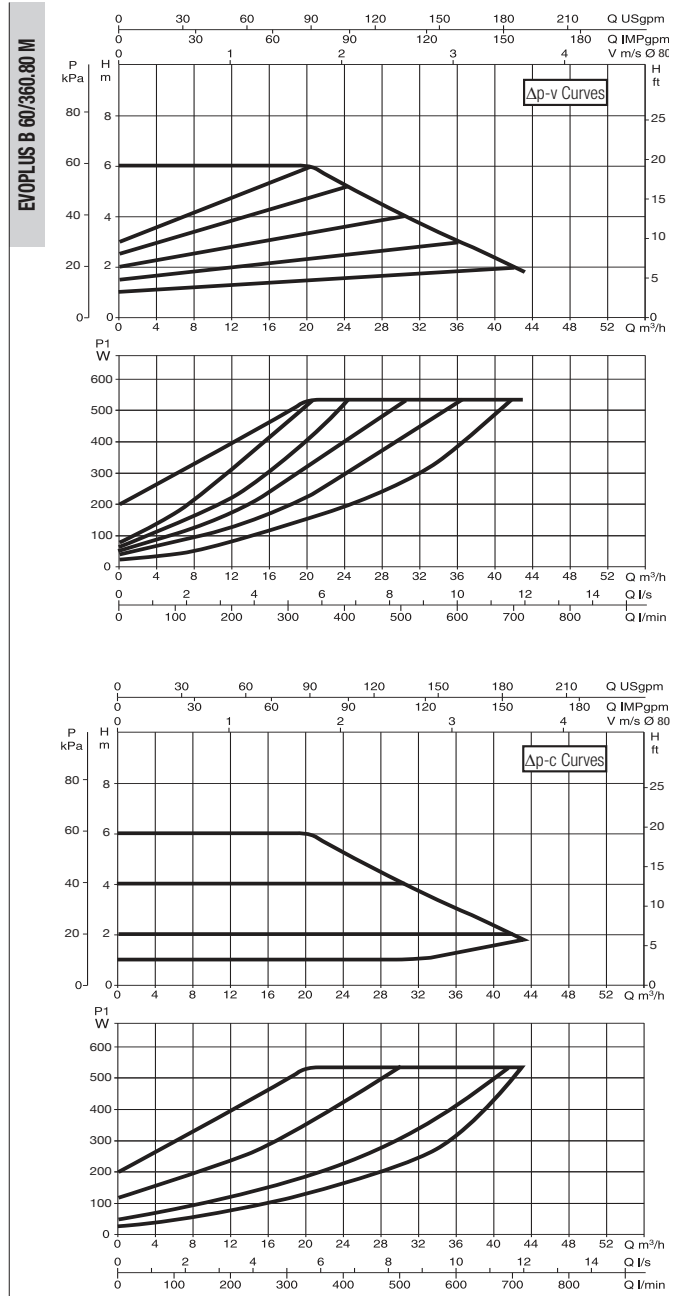
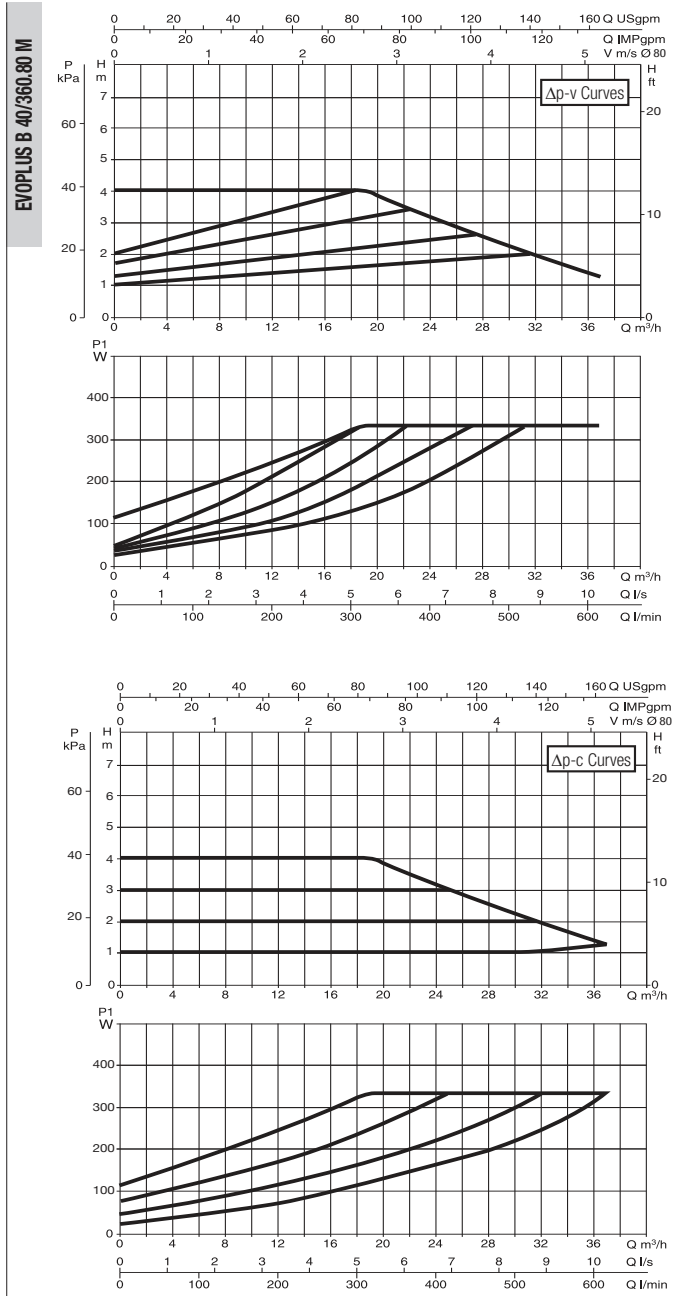

The curves are based on kinematic viscosity values = 1 mm²/s and density equal to 1000 kg/m³. Curve tolerance according to ISO 9906. Fixed speed curves available on the DNA.

MODEL	CENTRE DISTANCE mm	COUNTERFLANGES ON REQUEST	POWER INPUT 50/60 Hz	P1 MAX W	In A	EEI*	MINIMUM SUCTION PRESSURE			WEIGHT Kg
							t°	90°	100°	
EVOPLUS B 40/360.80 M	360	DN80 PN 10	220/240 V	330	1,65	EEI ≤ 0,19	m.c.w.	20	25	30,2
EVOPLUS B 60/360.80 M	360	DN80 PN 10	220/240 V	535	2,5	EEI ≤ 0,20	m.c.w.	20	25	30,2

*The parameter of reference for the more efficient circulators is EEI ≤ 0,20.

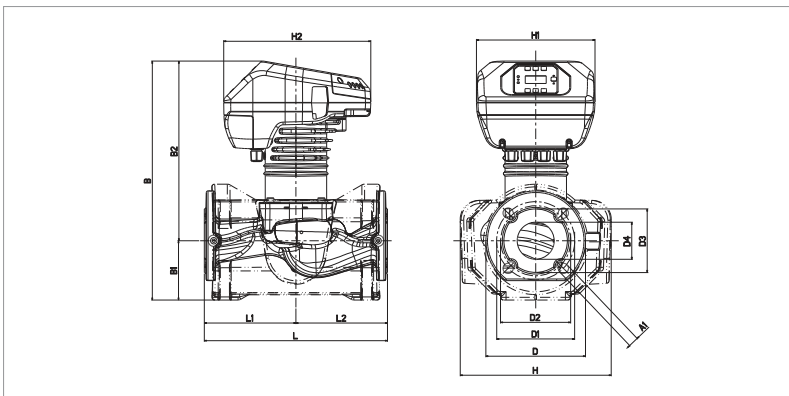

L	L1	L2	A1	B	B1	B2	D
360	180	180	19	446	106	340	200

D1	D3	D4	H	H1	H2
160	132	80	279	220	273

EVOPLUS - WET ROTOR ELECTRONIC CIRCULATORS

Pumped liquid temperature range: from -10 °C to +110 °C - Maximum operating pressure: 16 bar (1600 kPa)

EVOPLUS B 80/360.80 M

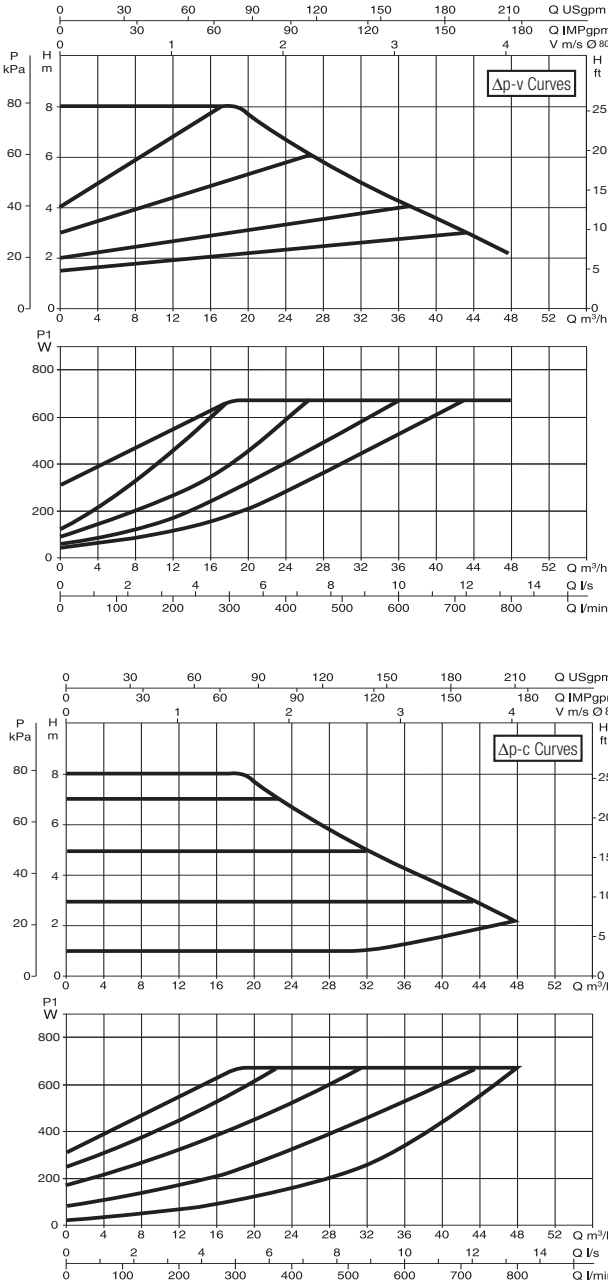

EVOPLUS B 100/360.80 M

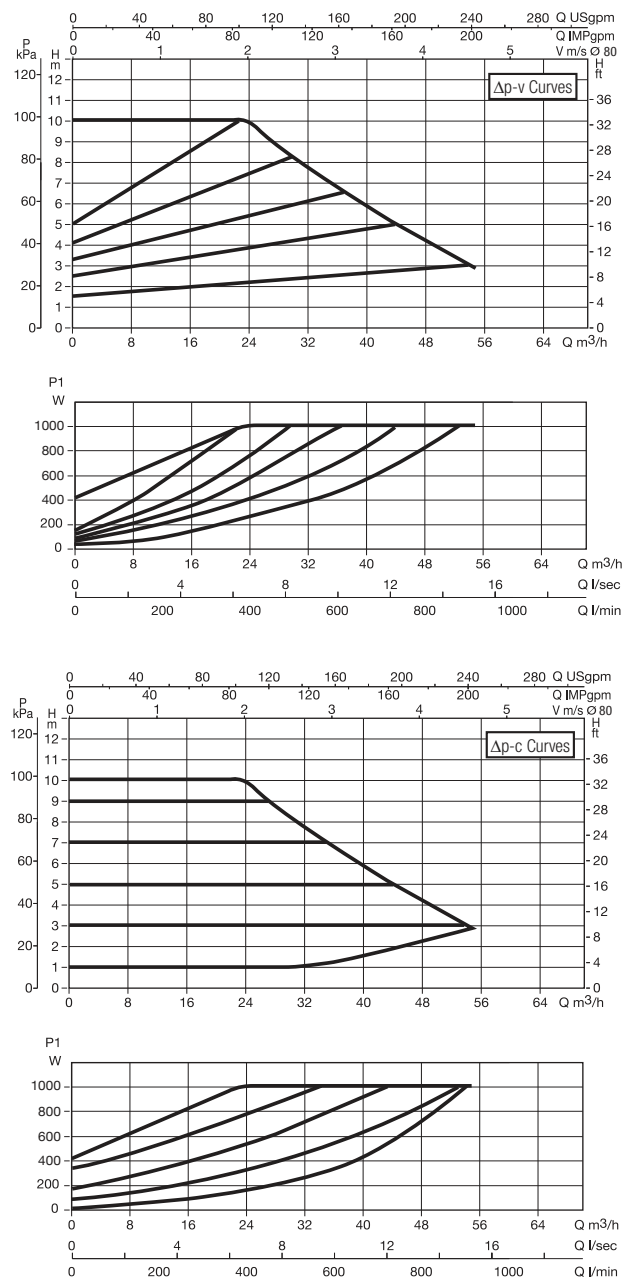

The curves are based on kinematic viscosity values = 1 mm²/s and density equal to 1000 kg/m³. Curve tolerance according to ISO 9906. Fixed speed curves available on the DNA.

MODEL	CENTRE DISTANCE mm	COUNTERFLANGES ON REQUEST	POWER INPUT 50/60 Hz	P1 MAX W	In A	EEI*	MINIMUM SUCTION PRESSURE			WEIGHT Kg
							t°	90°	100°	
EVOPLUS B 80/360.80 M	360	DN80 PN 10	220/240 V	670	3	EEI ≤ 0,20	m.c.w.	20	25	32
EVOPLUS B 100/360.80 M	360	DN80 PN 10	220/240 V	1005	4,5	EEI ≤ 0,19	m.c.w.	20	25	32,2

*The parameter of reference for the more efficient circulators is EEI ≤ 0,20.

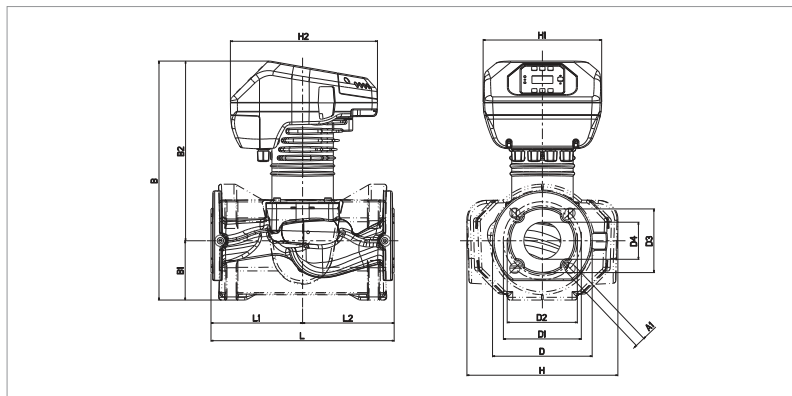

L	L1	L2	A1	B	B1	B2	D
360	180	180	19	360	180	180	19

D1	D3	D4	H	H1	H2
160	132	80	279	220	273

EVOPLUS - WET ROTOR ELECTRONIC CIRCULATORS

Pumped liquid temperature range: from -10 °C to +110 °C - Maximum operating pressure: 16 bar (1600 kPa)

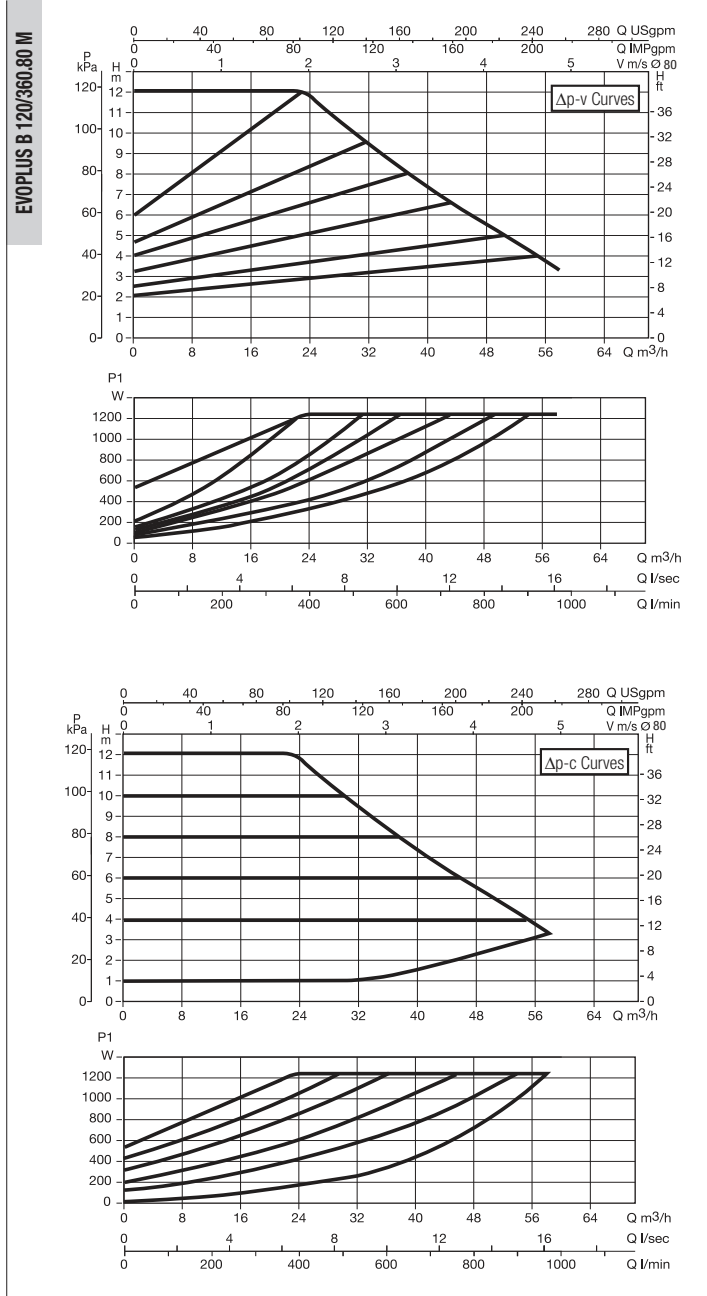

The curves are based on kinematic viscosity values = 1 mm²/s and density equal to 1000 kg/m³. Curve tolerance according to ISO 9906. Fixed speed curves available on the DNA.

MODEL	CENTRE DISTANCE mm	COUNTERFLANGES ON REQUEST	POWER INPUT 50/60 Hz	P1 MAX W	In A	EEI*	MINIMUM SUCTION PRESSURE			WEIGHT Kg
							t°	90°	100°	
EVOPLUS B 120/360.80 M	360	DN80 PN 10	220/240 V	1235	5,5	EEI ≤ 0,19	m.c.w.	20	25	32,2

* The parameter of reference for the more efficient circulators is EEI ≤ 0,20.

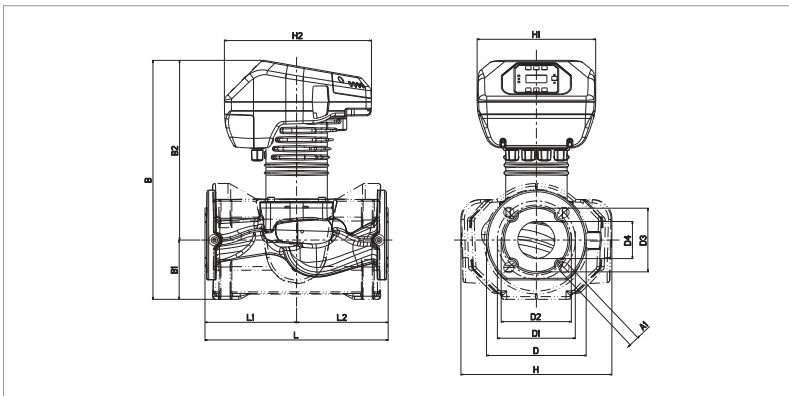

L	L1	L2	A1	B	B1	B2	D
360	180	180	19	446	106	340	200

D1	D3	D4	H	H1	H2
160	132	80	279	220	273

EVOPLUS - WET ROTOR ELECTRONIC CIRCULATORS

Pumped liquid temperature range: from -10 °C to +110 °C - Maximum operating pressure: 16 bar (1600 kPa)

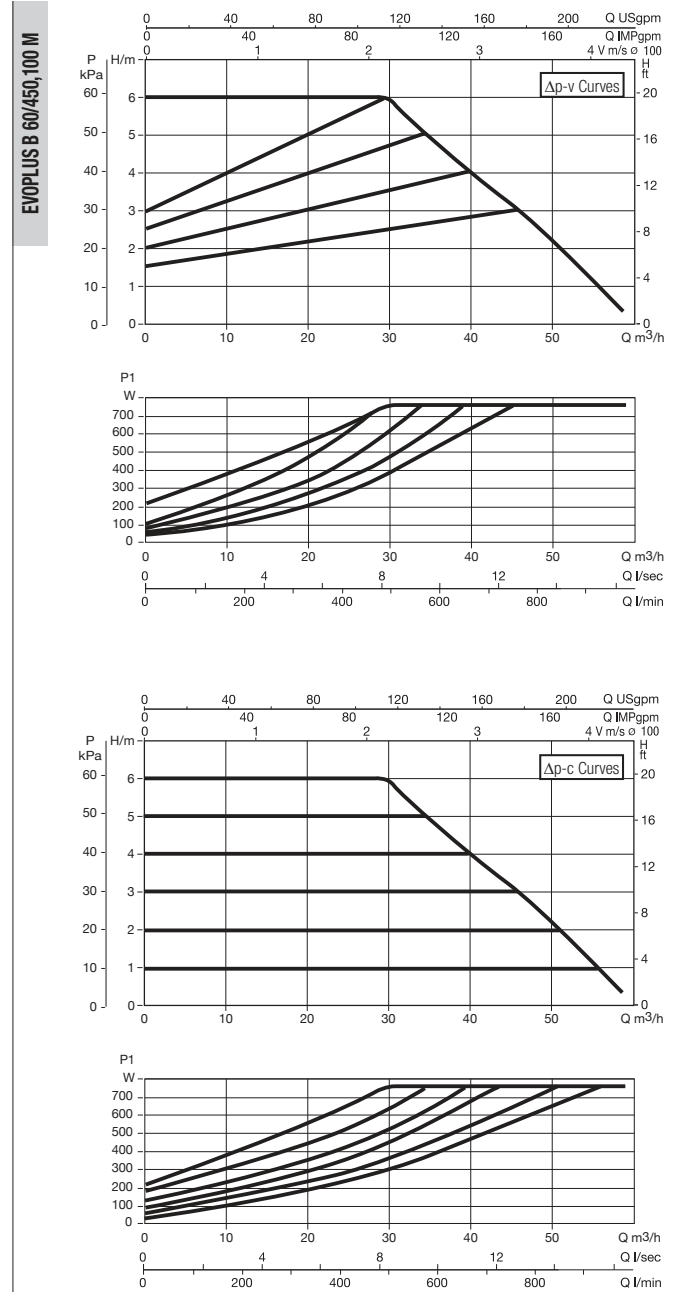
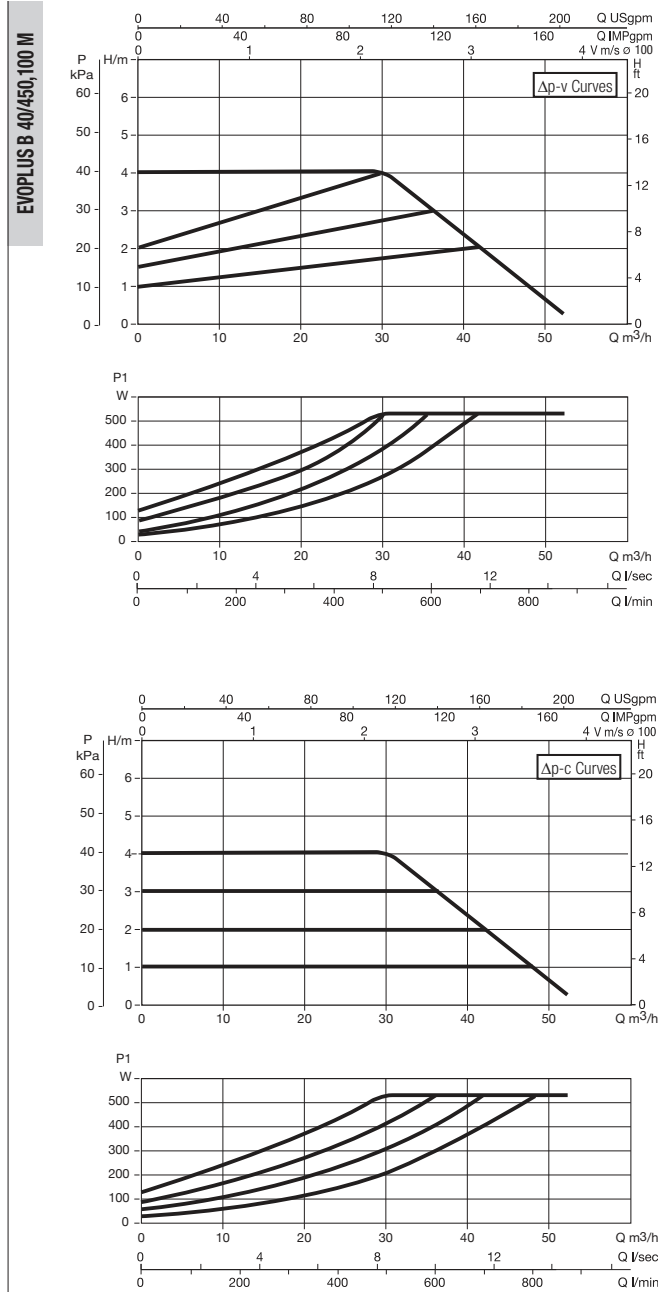

The curves are based on kinematic viscosity values = 1 mm²/s and density equal to 1000 kg/m³. Curve tolerance according to ISO 9906. Fixed speed curves available on the DNA.

MODEL	CENTRE DISTANCE mm	COUNTERFLANGES ON REQUEST	POWER INPUT 50/60 Hz	P1 MAX W	In A	EEI*	MINIMUM SUCTION PRESSURE			WEIGHT Kg
							t°	90°	100°	
EVOPLUS B 40/450.100 M	450	DN100 PN 10	220/240 V	530	2,5	EEI ≤ 0,19	m.c.w.	20	25	37,5
EVOPLUS B 60/450.100 M	450	DN100 PN 10	220/240 V	760	3,5	EEI ≤ 0,18	m.c.w.	20	25	37,5

* The parameter of reference for the more efficient circulators is EEI ≤ 0,20.

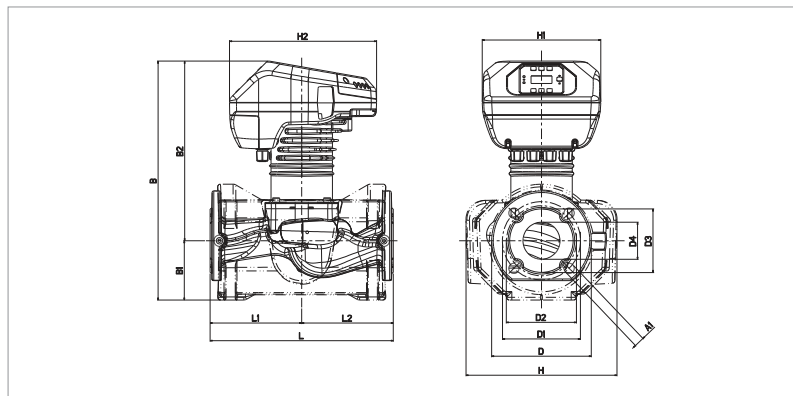

L	L1	L2	A1	B	B1	B2	D
450	225	225	19	463	110	353	220

D1	D3	D4	H	H1	H2
180	156	105	292	220	273

EVOPLUS - WET ROTOR ELECTRONIC CIRCULATORS

Pumped liquid temperature range: from -10 °C to +110 °C - Maximum operating pressure: 16 bar (1600 kPa)

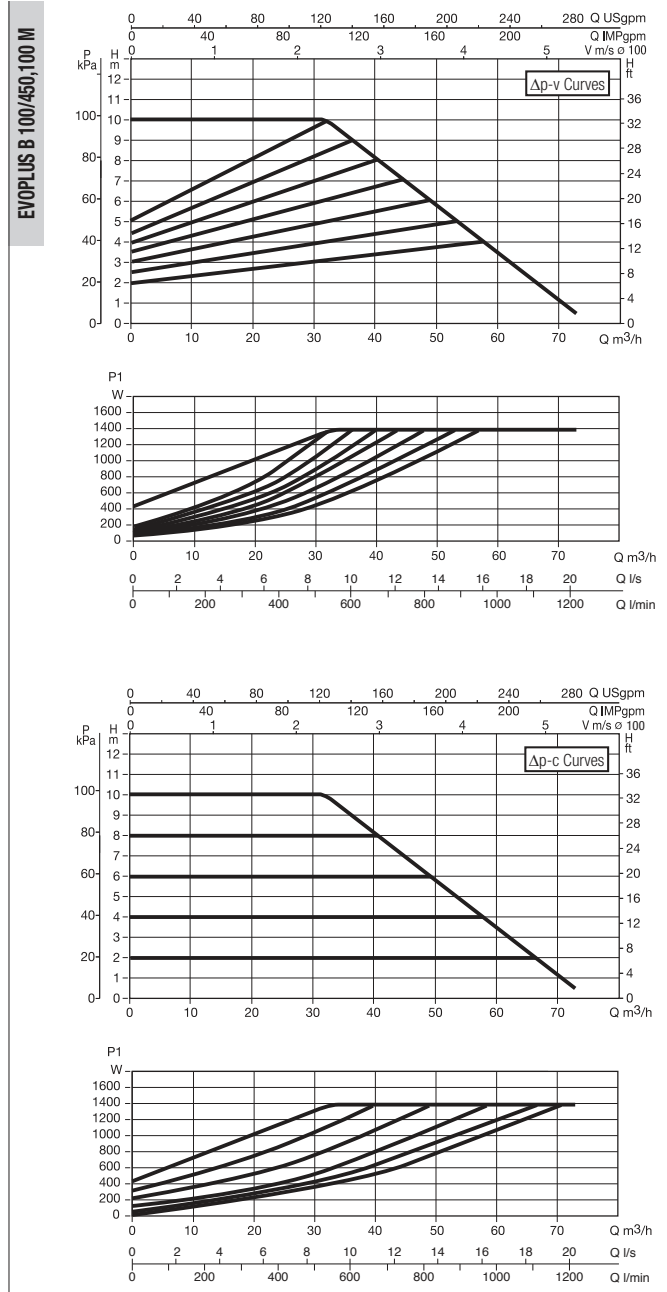
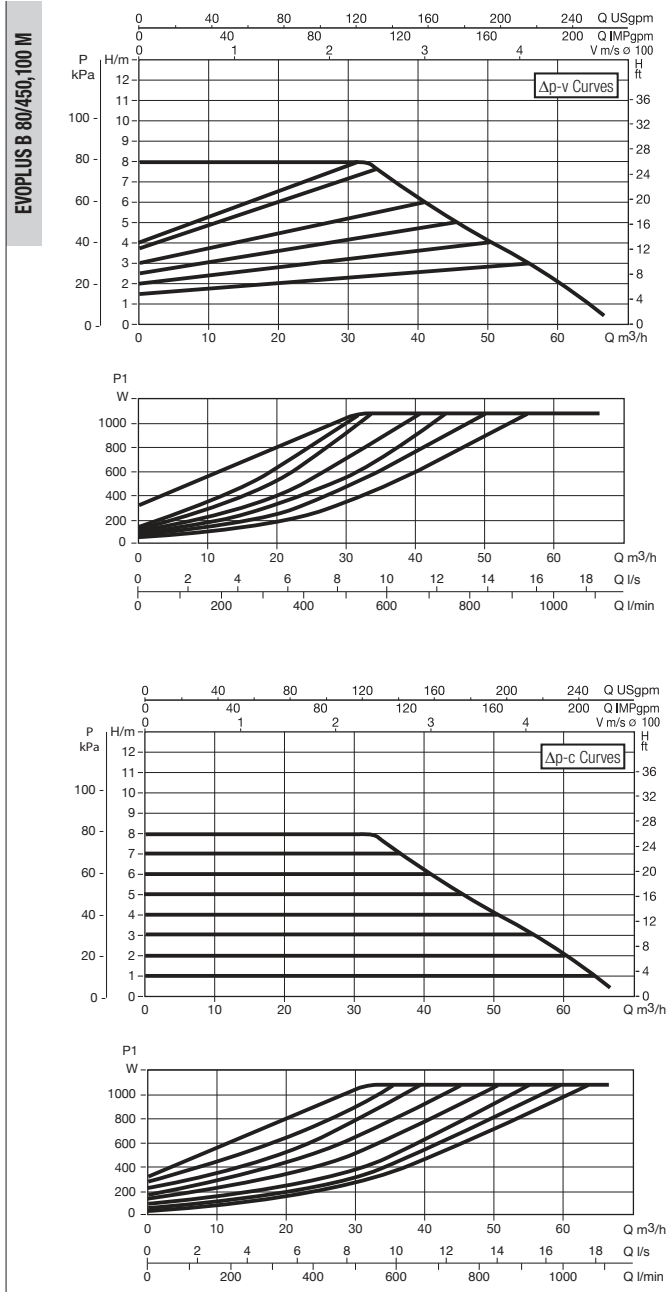

The curves are based on kinematic viscosity values = 1 mm²/s and density equal to 1000 kg/m³. Curve tolerance according to ISO 9906. Fixed speed curves available on the DNA.

MODEL	CENTRE DISTANCE mm	COUNTERFLANGES ON REQUEST	POWER INPUT 50/60 Hz	P1 MAX W	In A	EEI*	MINIMUM SUCTION PRESSURE			WEIGHT Kg
							t°	90°	100°	
EVOPLUS B 80/450.100 M	450	DN100 PN 10	220/240 V	1080	4,8	EEI ≤ 0,18	m.c.w.	20	25	36,6
EVOPLUS B 100/450.100 M	450	DN100 PN 10	220/240 V	1380	6	EEI ≤ 0,19	m.c.w.	20	25	36,8

* The parameter of reference for the more efficient circulators is EEI ≤ 0,20.

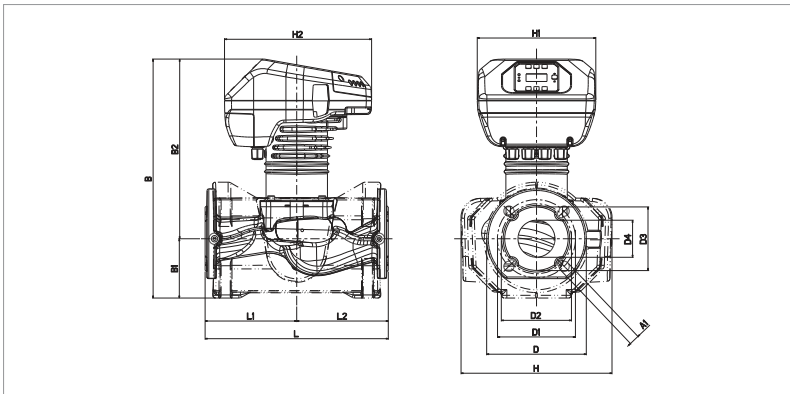

L	L1	L2	A1	B	B1	B2	D
450	225	225	19	463	110	353	220

D1	D3	D4	H	H1	H2
180	156	105	292	220	273

EVOPLUS - WET ROTOR ELECTRONIC CIRCULATORS

Pumped liquid temperature range: from -10 °C to +110 °C - Maximum operating pressure: 16 bar (1600 kPa)

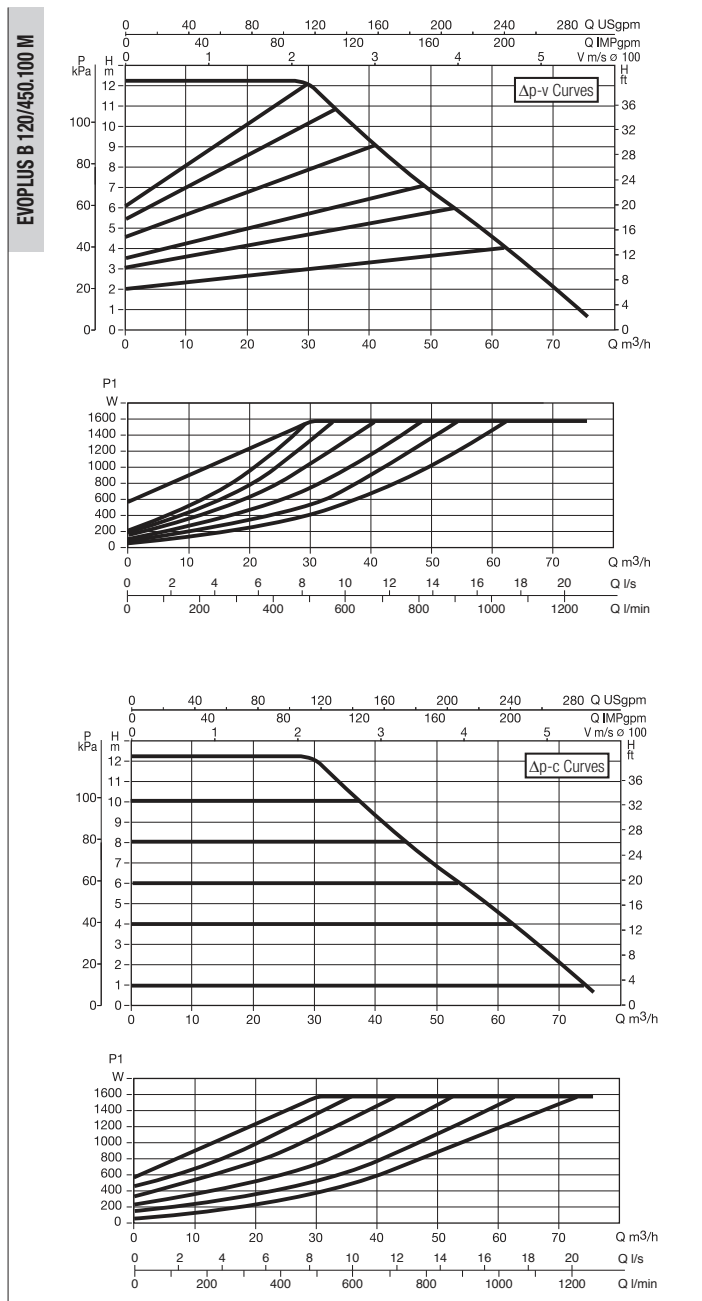

The curves are based on kinematic viscosity values = 1 mm²/s and density equal to 1000 kg/m³. Curve tolerance according to ISO 9906. Fixed speed curves available on the DNA.

MODEL	CENTRE DISTANCE mm	COUNTERFLANGES ON REQUEST	POWER INPUT 50/60 Hz	P1 MAX W	In A	EEI*	MINIMUM SUCTION PRESSURE			WEIGHT Kg
							t°	90°	100°	
EVOPLUS B 120/450.100 M	450	DN100 PN 10	220/240 V	1560	7	EEI ≤ 0,19	m.c.w.	20	25	36,3

* The parameter of reference for the more efficient circulators is EEI ≤ 0,20.

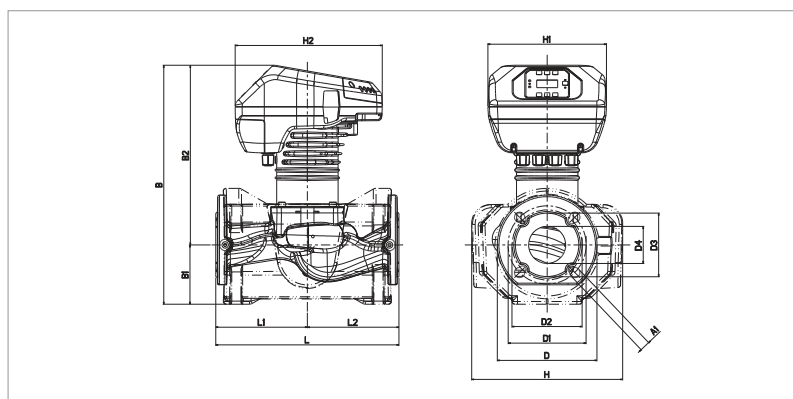

L	L1	L2	A1	B	B1	B2	D
450	225	225	19	463	110	353	220

D1	D3	D4	H	H1	H2
180	156	105	292	220	273

EVOPLUS - WET ROTOR ELECTRONIC CIRCULATORS

Pumped liquid temperature range: from -10 °C to +110 °C - Maximum operating pressure: 16 bar (1600 kPa)

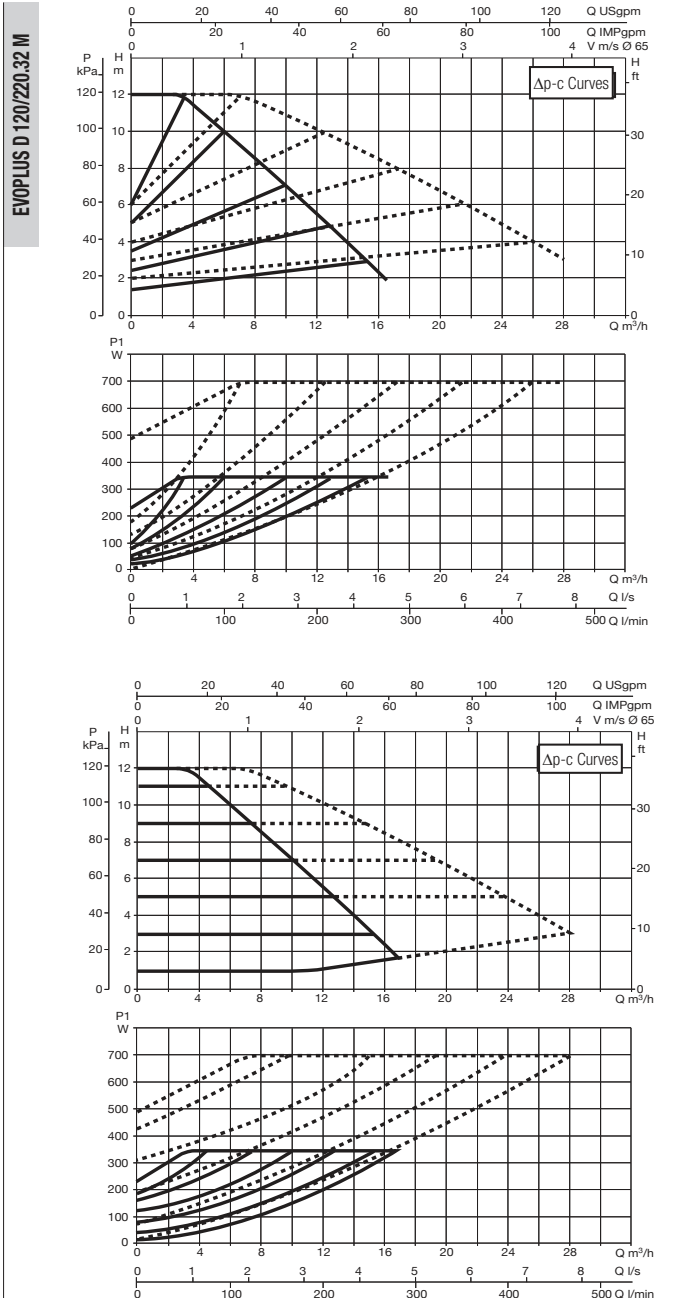

The curves are based on kinematic viscosity values = 1 mm²/s and density equal to 1000 kg/m³. Curve tolerance according to ISO 9906. Fixed speed curves available on the DNA.

MODEL	CENTRE DISTANCE mm	COUNTERFLANGES ON REQUEST	POWER INPUT 50/60 Hz	P1 MAX W	In A	EEI*	MINIMUM SUCTION PRESSURE			WEIGHT Kg
							t°	90°	100°	
EVOPLUS D 120/220.32 M	220	DN32 PN 6	220/240 V	340	1,7	EEI ≤ 0,22	m.c.w.	20	25	36,2

* The parameter of reference for the more efficient circulators is EEI ≤ 0,20.

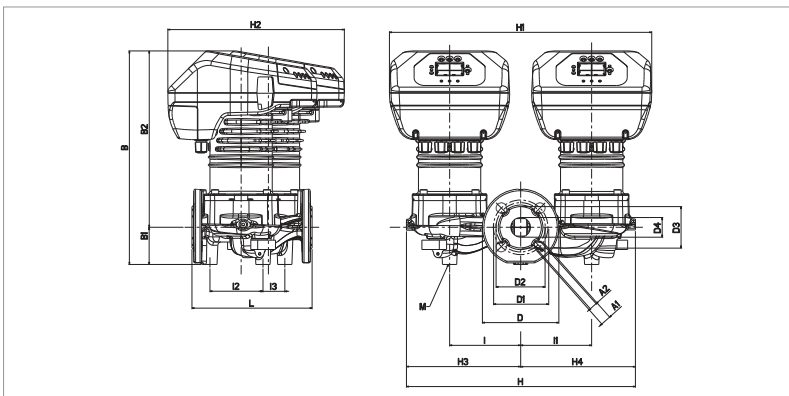

L	A1	A2	B	B1	B2	D	D1	D2	D3	D4
220	19	14	391	68	323	140	100	90	76	36

I	I1	I2	I3	M	H	H1	H2	H3	H4
130	130	97	40	M12	419	480	323	209	210

EVOPLUS - WET ROTOR ELECTRONIC CIRCULATORS

Pumped liquid temperature range: from -10 °C to +110 °C - Maximum operating pressure: 16 bar (1600 kPa)

EVOPLUS D 40/220.40 M

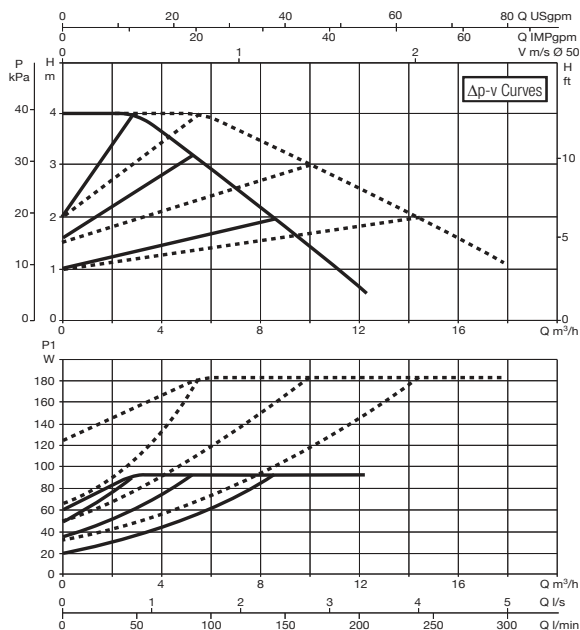

EVOPLUS D 60/220.40 M

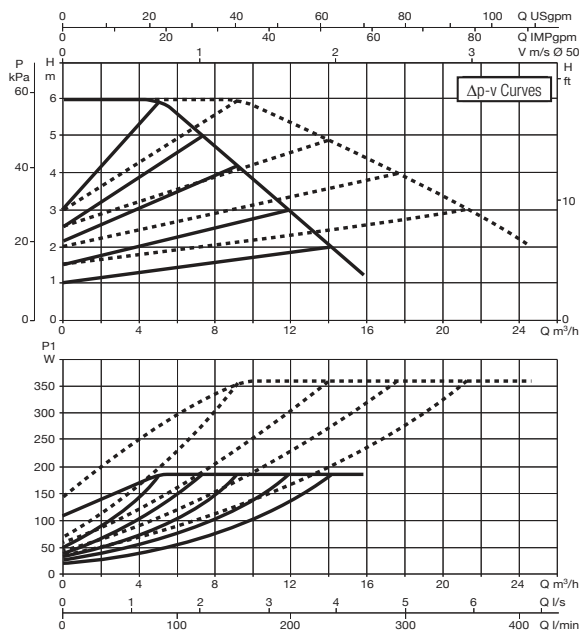

The curves are based on kinematic viscosity values = 1 mm²/s and density equal to 1000 kg/m³. Curve tolerance according to ISO 9906. Fixed speed curves available on the DNA.

MODEL	CENTRE DISTANCE mm	COUNTERFLANGES ON REQUEST	POWER INPUT 50/60 Hz	P1 MAX W	In A	EEI*	MINIMUM SUCTION PRESSURE			WEIGHT Kg
							t°	90°	100°	
EVOPLUS D 40/220.40 M	220	DN40 PN 10	220/240 V	90	0,7	EEI ≤ 0,23	m.c.w.	20	25	38,6
EVOPLUS D 60/220.40 M	220	DN40 PN 10	220/240 V	175	1	EEI ≤ 0,23	m.c.w.	20	25	38,6

* The parameter of reference for the more efficient circulators is EEI ≤ 0,20.

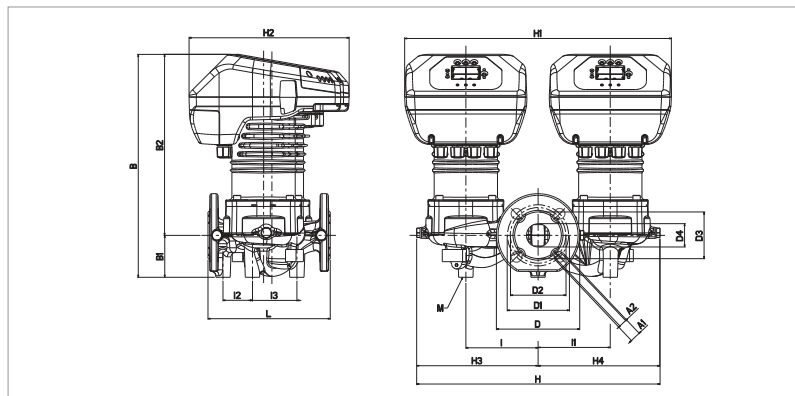

L	A1	A2	B	B1	B2	D	D1	D2	D3	D4
220	19	14	436	75	361	150	110	100	84	42

I	I1	I2	I3	M	H	H1	H2	H3	H4
130	130	53	80	M12	438	480	288	219	218

EVOPLUS - WET ROTOR ELECTRONIC CIRCULATORS

Pumped liquid temperature range: from -10 °C to +110 °C - Maximum operating pressure: 16 bar (1600 kPa)

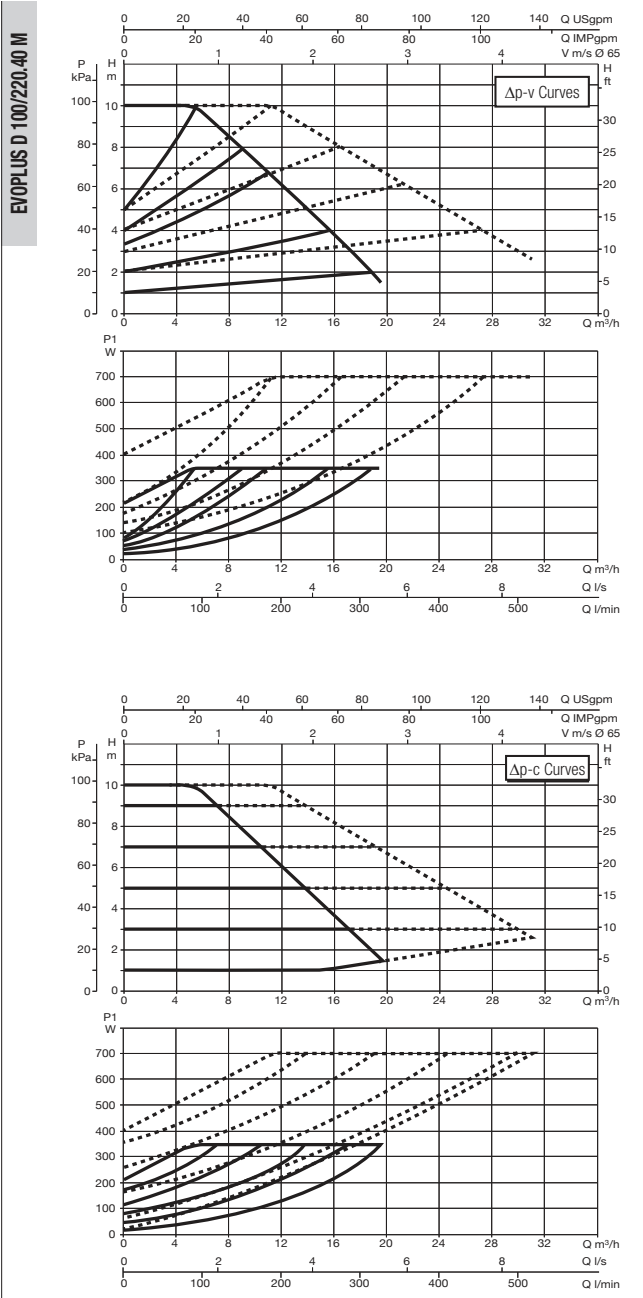
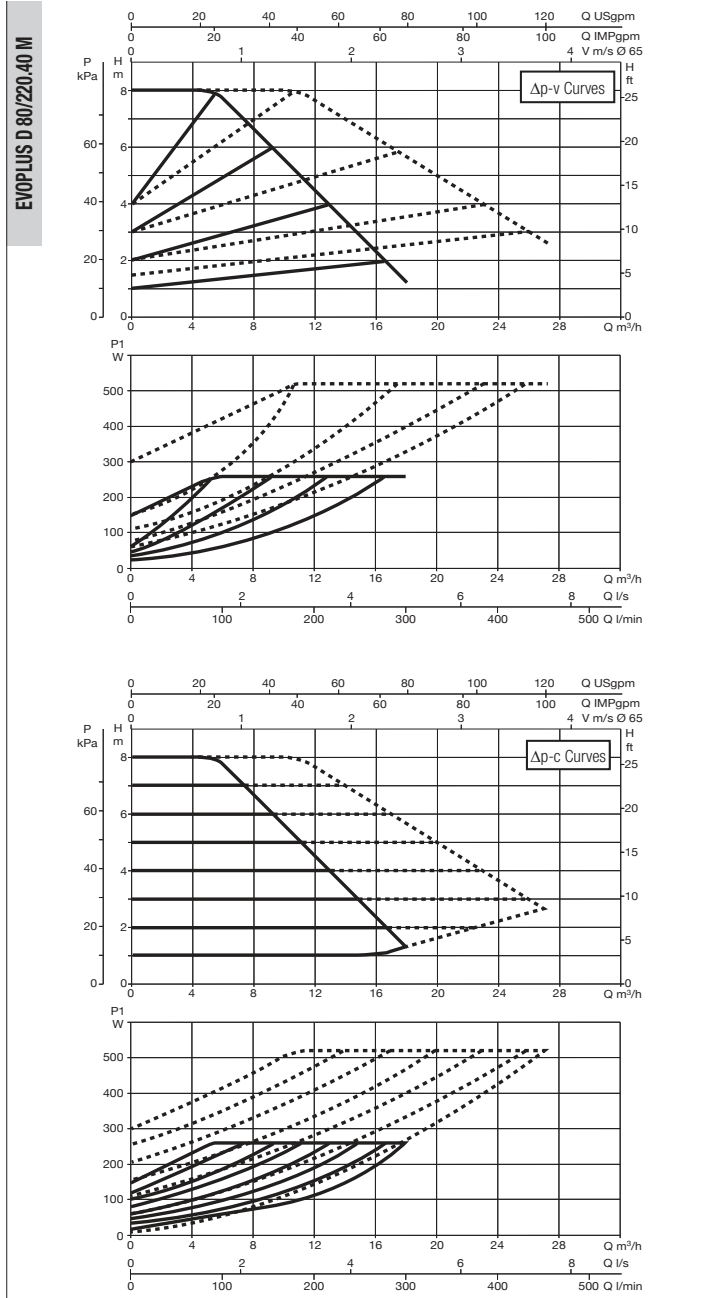

The curves are based on kinematic viscosity values = 1 mm²/s and density equal to 1000 kg/m³. Curve tolerance according to ISO 9906. Fixed speed curves available on the DNA.

MODEL	CENTRE DISTANCE mm	COUNTERFLANGES ON REQUEST	POWER INPUT 50/60 Hz	P1 MAX W	In A	EEI*	MINIMUM SUCTION PRESSURE			WEIGHT Kg
							t°	90°	100°	
EVOPLUS D 80/220.40 M	220	DN40 PN 10	220/240 V	260	1,35	EEI ≤ 0,23	m.c.w.	20	25	38,6
EVOPLUS D 100/220.40 M	220	DN40 PN 10	220/240 V	350	1,75	EEI ≤ 0,23	m.c.w.	20	25	38,6

* The parameter of reference for the more efficient circulators is EEI ≤ 0,20.

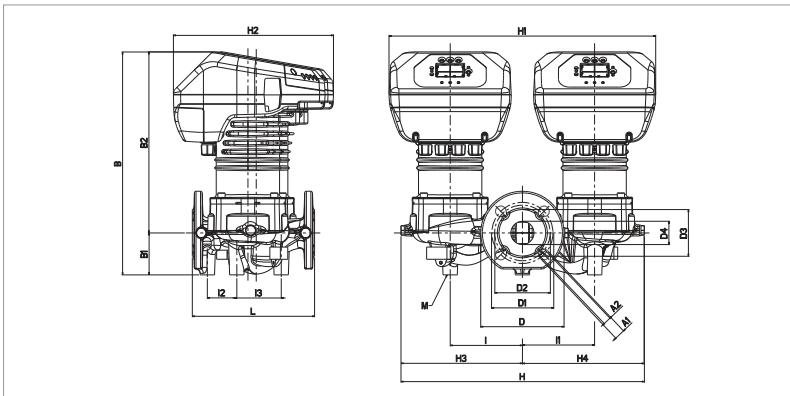

L	A1	A2	B	B1	B2	D	D1	D2	D3	D4
220	19	14	436	75	361	150	110	100	84	42

I	I1	I2	I3	M	H	H1	H2	H3	H4
130	130	53	80	M12	438	480	288	219	218

EVOPLUS - WET ROTOR ELECTRONIC CIRCULATORS

Pumped liquid temperature range: from -10 °C to +110 °C - Maximum operating pressure: 16 bar (1600 kPa)

EVOPLUS D 120/250.40 M

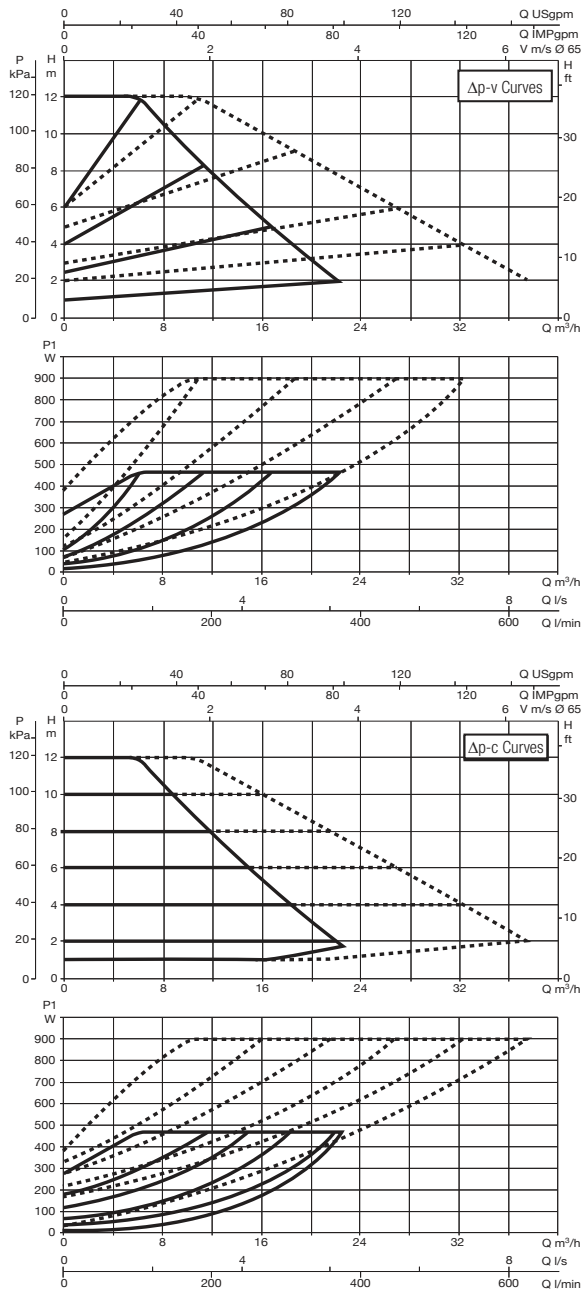

EVOPLUS D 150/250.40 M

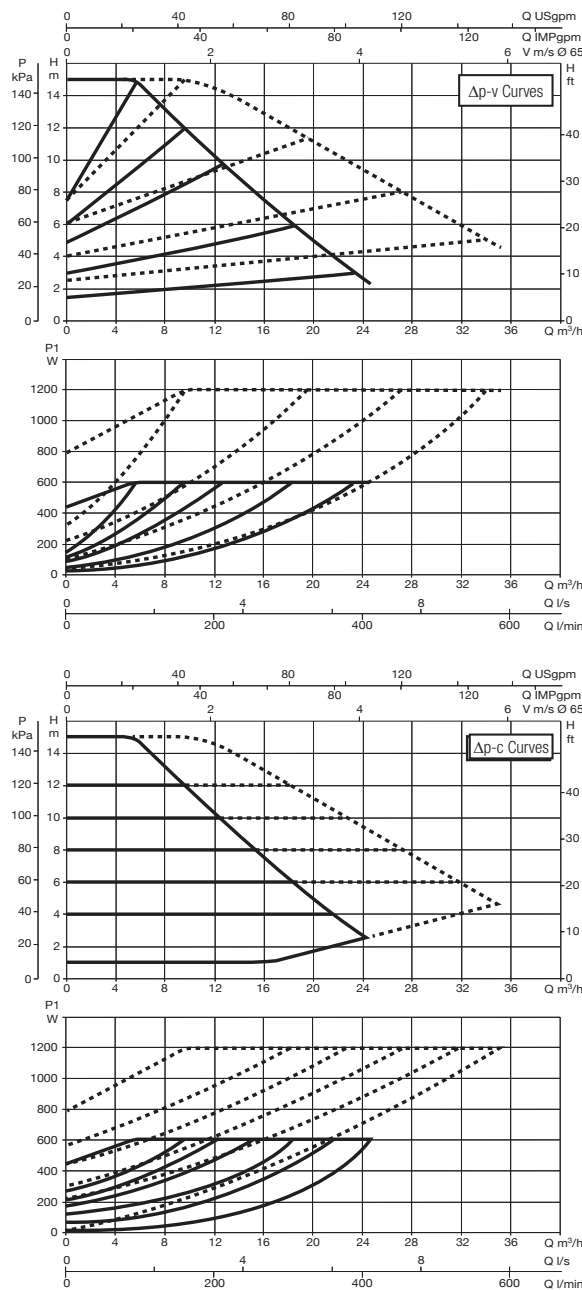

The curves are based on kinematic viscosity values = 1 mm²/s and density equal to 1000 kg/m³. Curve tolerance according to ISO 9906. Fixed speed curves available on the DNA.

MODEL	CENTRE DISTANCE mm	COUNTERFLANGES ON REQUEST	POWER INPUT 50/60 Hz	P1 MAX W	In A	EEI*	MINIMUM SUCTION PRESSURE			WEIGHT Kg
							t°	90°	100°	
EVOPLUS D 120/250.40 M	250	DN40 PN 10	220/240 V	465	2,2	EEI ≤ 0,23	m.c.w.	20	25	38,8
EVOPLUS D 150/250.40 M	250	DN40 PN 10	220/240 V	610	2,9	EEI ≤ 0,23	m.c.w.	20	25	38,8

* The parameter of reference for the more efficient circulators is EEI ≤ 0,20.

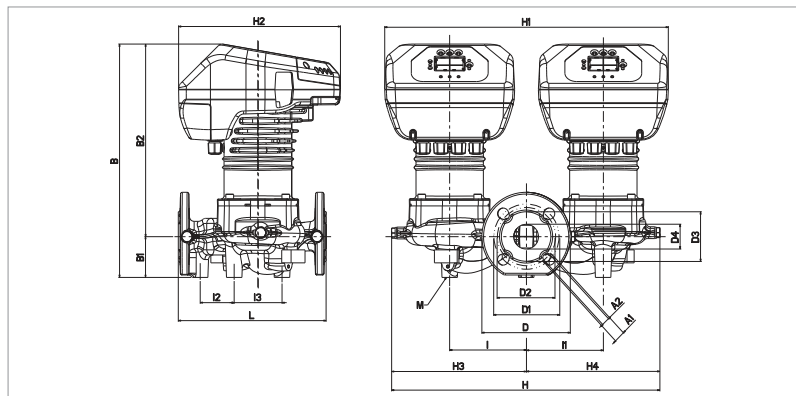

L	A1	A2	B	B1	B2	D	D1	D2	D3	D4
250	19	14	395	69	326	150	110	100	84	42

I	I1	I2	I3	M	H	H1	H2	H3	H4
130	130	58	81	M12	454	480	274	228	226

EVOPLUS - WET ROTOR ELECTRONIC CIRCULATORS

Pumped liquid temperature range: from -10 °C to +110 °C - Maximum operating pressure: 16 bar (1600 kPa)

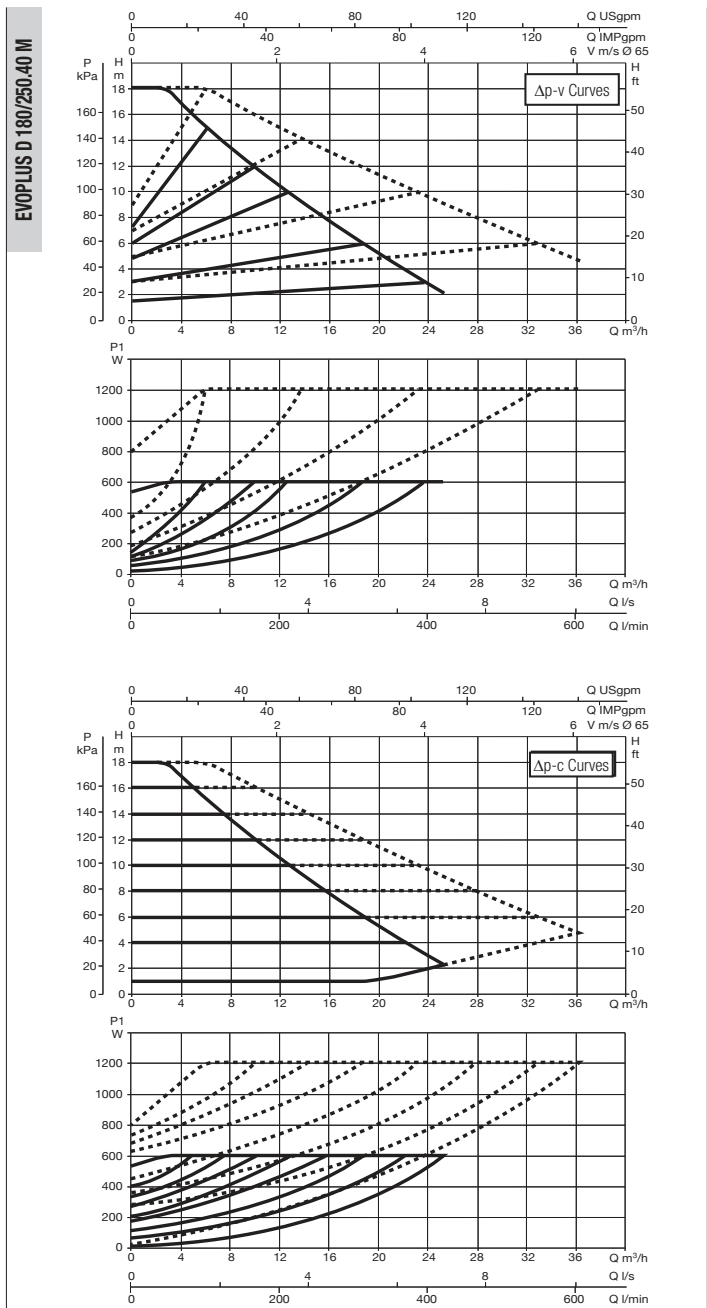

The curves are based on kinematic viscosity values = 1 mm²/s and density equal to 1000 kg/m³. Curve tolerance according to ISO 9906. Fixed speed curves available on the DNA.

MODEL	CENTRE DISTANCE mm	COUNTERFLANGES ON REQUEST	POWER INPUT 50/60 Hz	P1 MAX W	In A	EEI*	MINIMUM SUCTION PRESSURE			WEIGHT Kg
							t°	90°	100°	
EVOPLUS D 180/250.40 M	250	DN40 PN 10	220/240 V	610	2,9	EEI ≤ 0,23	m.c.w.	20	25	38,8

* The parameter of reference for the more efficient circulators is EEI ≤ 0,20.

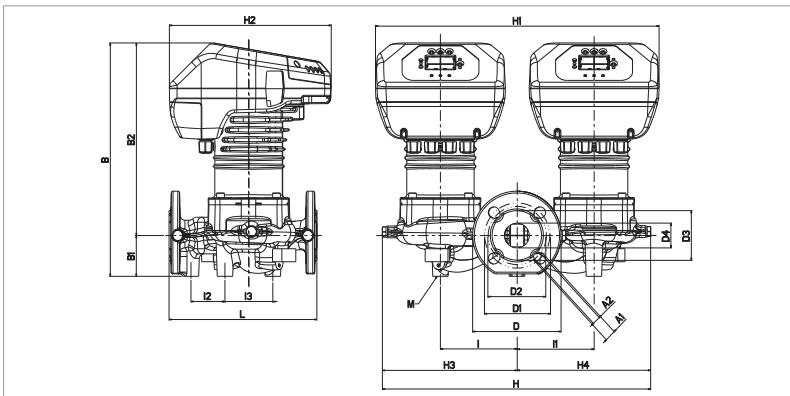

L	A1	A2	B	B1	B2	D	D1	D2	D3	D4
250	19	14	395	69	326	150	110	100	84	42

I	I1	I2	I3	M	H	H1	H2	H3	H4
130	130	58	81	M12	454	480	274	228	226

EVOPLUS - WET ROTOR ELECTRONIC CIRCULATORS

Pumped liquid temperature range: from -10 °C to +110 °C - Maximum operating pressure: 16 bar (1600 kPa)

EVOPLUS D 40/240.50 M

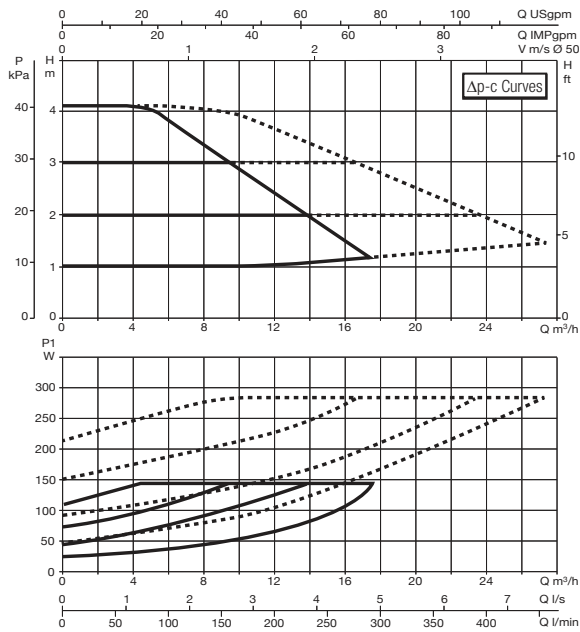
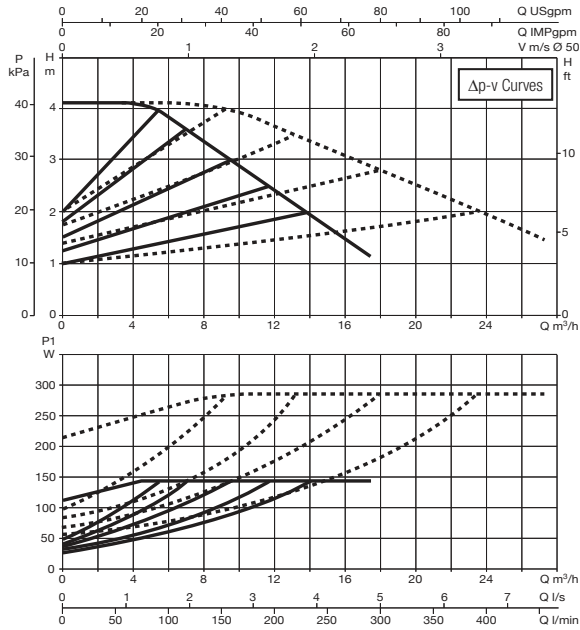

EVOPLUS D 60/240.50 M

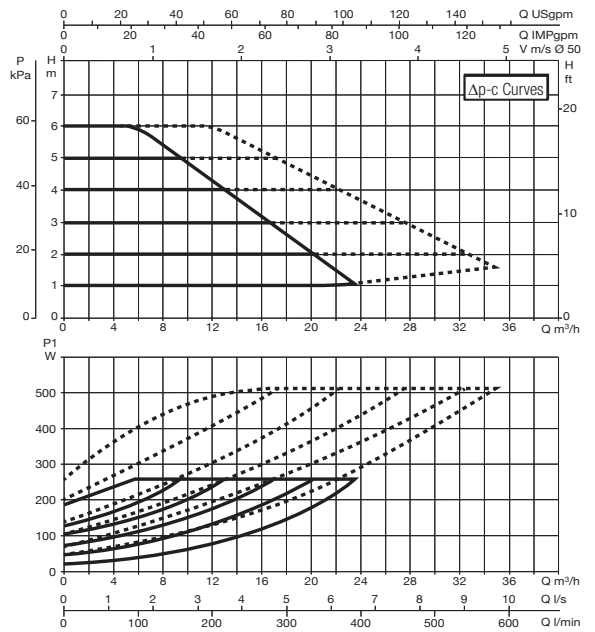
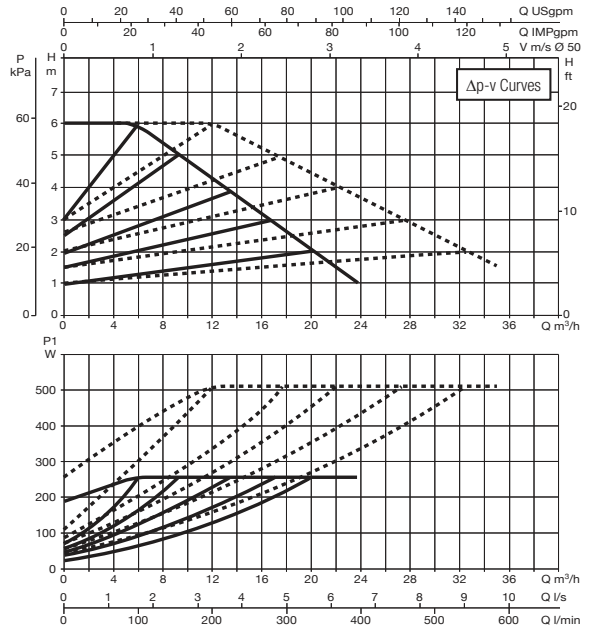

The curves are based on kinematic viscosity values = 1 mm²/s and density equal to 1000 kg/m³. Curve tolerance according to ISO 9906. Fixed speed curves available on the DNA.

MODEL	CENTRE DISTANCE mm	COUNTERFLANGES ON REQUEST	POWER INPUT 50/60 Hz	P1 MAX W	In A	EEI*	MINIMUM SUCTION PRESSURE			WEIGHT Kg
							t°	90°	100°	
EVOPLUS D 40/240.50 M	240	DN50 PN 10	220/240 V	140	0,87	EEI ≤ 0,23	m.c.w.	20	25	40
EVOPLUS D 60/240.50 M	240	DN50 PN 10	220/240 V	260	1,35	EEI ≤ 0,22	m.c.w.	20	25	40

* The parameter of reference for the more efficient circulators is EEI ≤ 0,20.

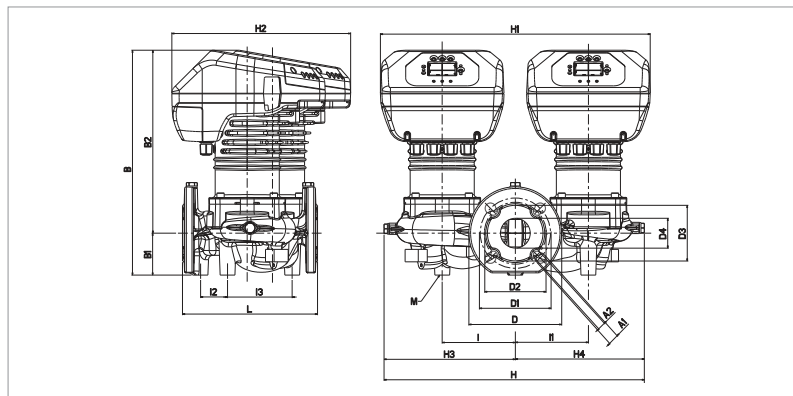

L	A1	A2	B	B1	B2	D	D1	D2	D3	D4
240	19	14	400	75	325	165	125	110	99	53

I	I1	I2	I3	M	H	H1	H2	H3	H4
130	130	48	115	M12	463	480	318	233	230

EVOPLUS - WET ROTOR ELECTRONIC CIRCULATORS

Pumped liquid temperature range: from -10 °C to +110 °C - Maximum operating pressure: 16 bar (1600 kPa)

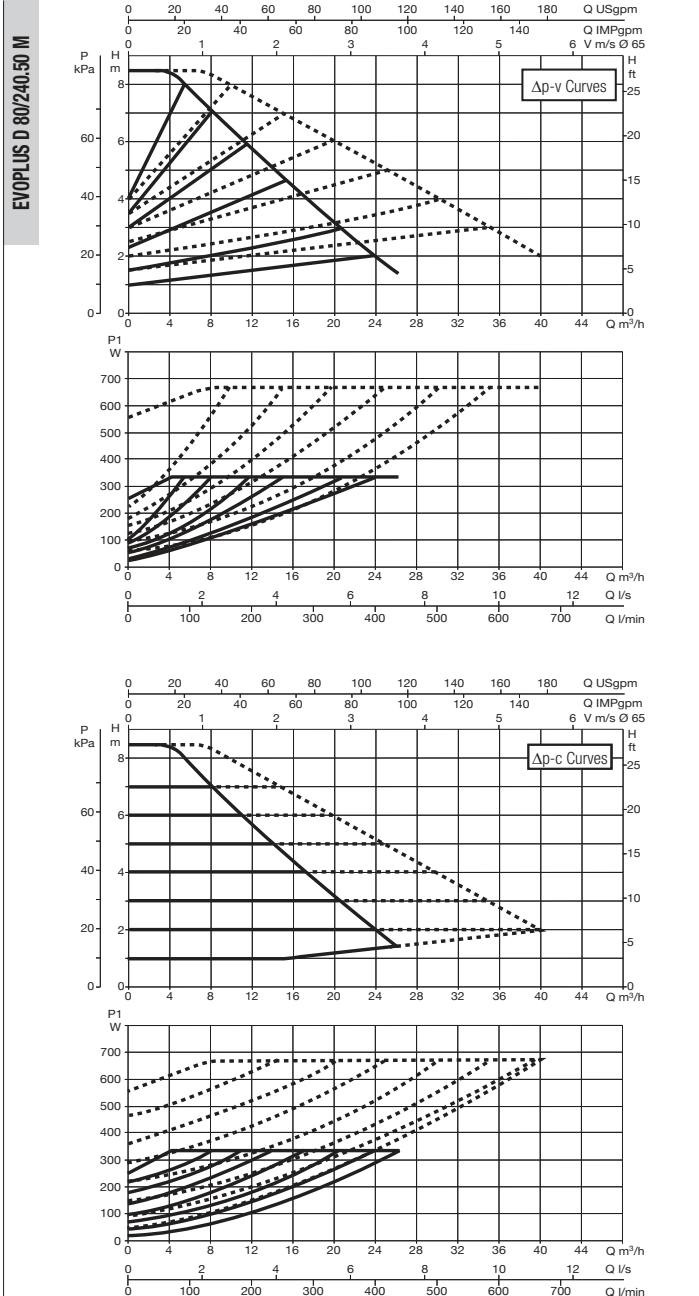

The curves are based on kinematic viscosity values = 1 mm²/s and density equal to 1000 kg/m³. Curve tolerance according to ISO 9906. Fixed speed curves available on the DNA.

MODEL	CENTRE DISTANCE mm	COUNTERFLANGES ON REQUEST	POWER INPUT 50/60 Hz	P1 MAX W	In A	EEI*	MINIMUM SUCTION PRESSURE			WEIGHT Kg
							t°	90°	100°	
EVOPLUS D 80/240.50 M	240	DN50 PN 10	220/240 V	330	1,7	EEI ≤ 0,22	m.c.w.	20	25	40

* The parameter of reference for the more efficient circulators is EEI ≤ 0,20.

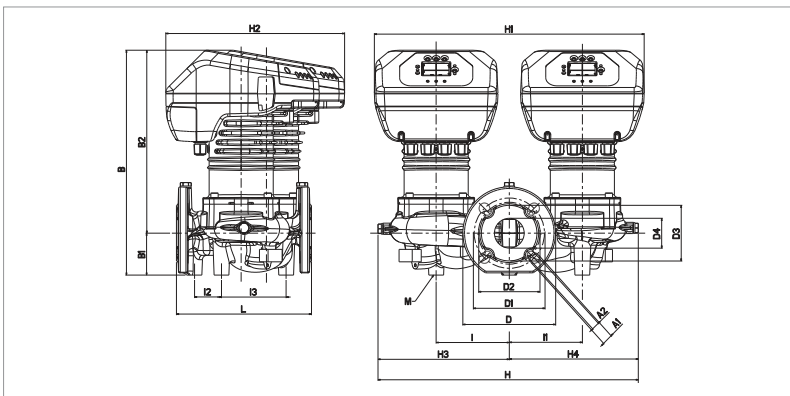

L	A1	A2	B	B1	B2	D	D1	D2	D3	D4
240	19	14	400	75	325	165	125	110	99	53

I	I1	I2	I3	M	H	H1	H2	H3	H4
130	130	48	115	M12	463	480	318	233	230

EVOPLUS - WET ROTOR ELECTRONIC CIRCULATORS

Pumped liquid temperature range: from -10 °C to +110 °C - Maximum operating pressure: 16 bar (1600 kPa)

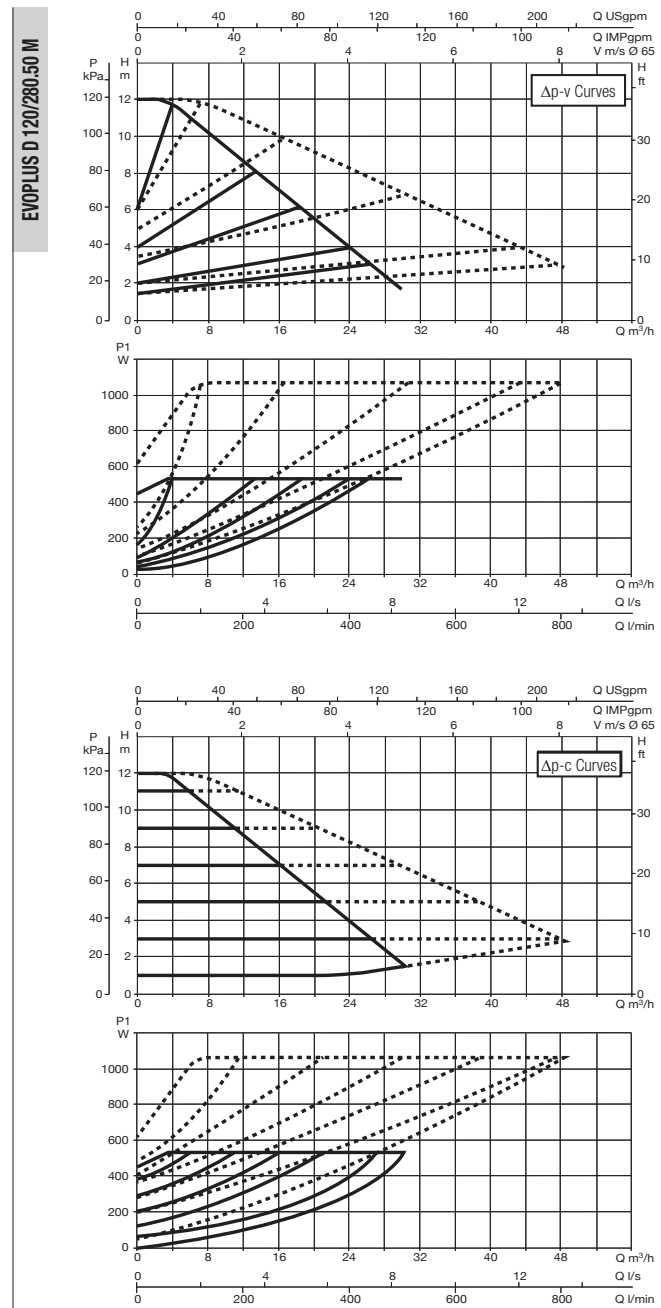
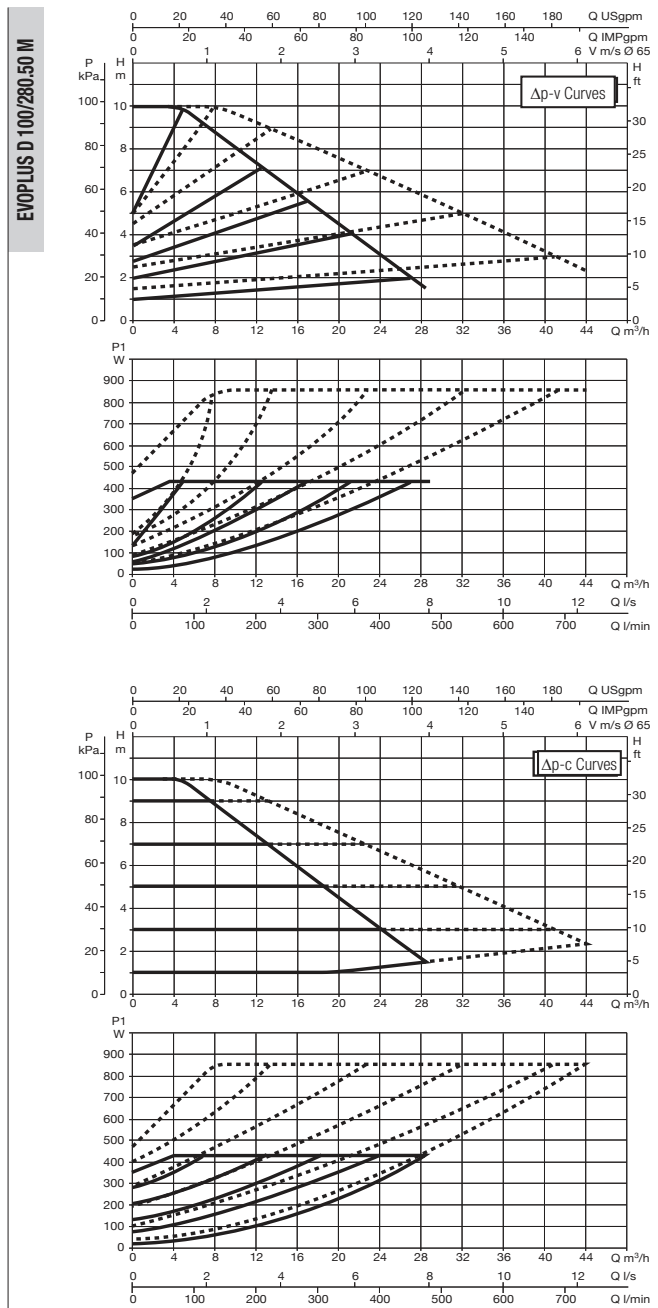

The curves are based on kinematic viscosity values = 1 mm²/s and density equal to 1000 kg/m³. Curve tolerance according to ISO 9906. Fixed speed curves available on the DNA.

MODEL	CENTRE DISTANCE mm	COUNTERFLANGES ON REQUEST	POWER INPUT 50/60 Hz	P1 MAX W	In A	EEI*	MINIMUM SUCTION PRESSURE			WEIGHT Kg
							t°	90°	100°	
EVOPLUS D 100/280.50 M	280	DN50 PN 10	220/240 V	430	2,1	EEI ≤ 0,22	m.c.w.	20	25	39,4
EVOPLUS D 120/280.50 M	280	DN50 PN 10	220/240 V	530	2,5	EEI ≤ 0,22	m.c.w.	20	25	39,6

* The parameter of reference for the more efficient circulators is EEI ≤ 0,20.

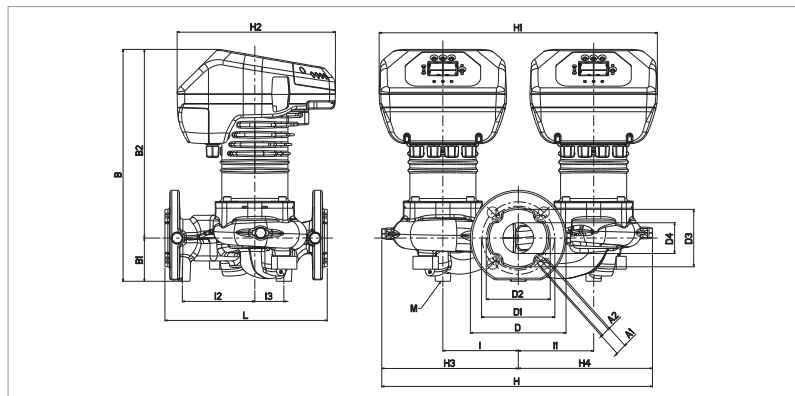

L	A1	A2	B	B1	B2	D	D1	D2	D3	D4
280	19	14	400	75	325	165	125	110	99	53

I	I1	I2	I3	M	H	H1	H2	H3	H4
130	130	125	50	M12	467	480	273	235	232

EVOPLUS - WET ROTOR ELECTRONIC CIRCULATORS

Pumped liquid temperature range: from -10 °C to +110 °C - Maximum operating pressure: 16 bar (1600 kPa)

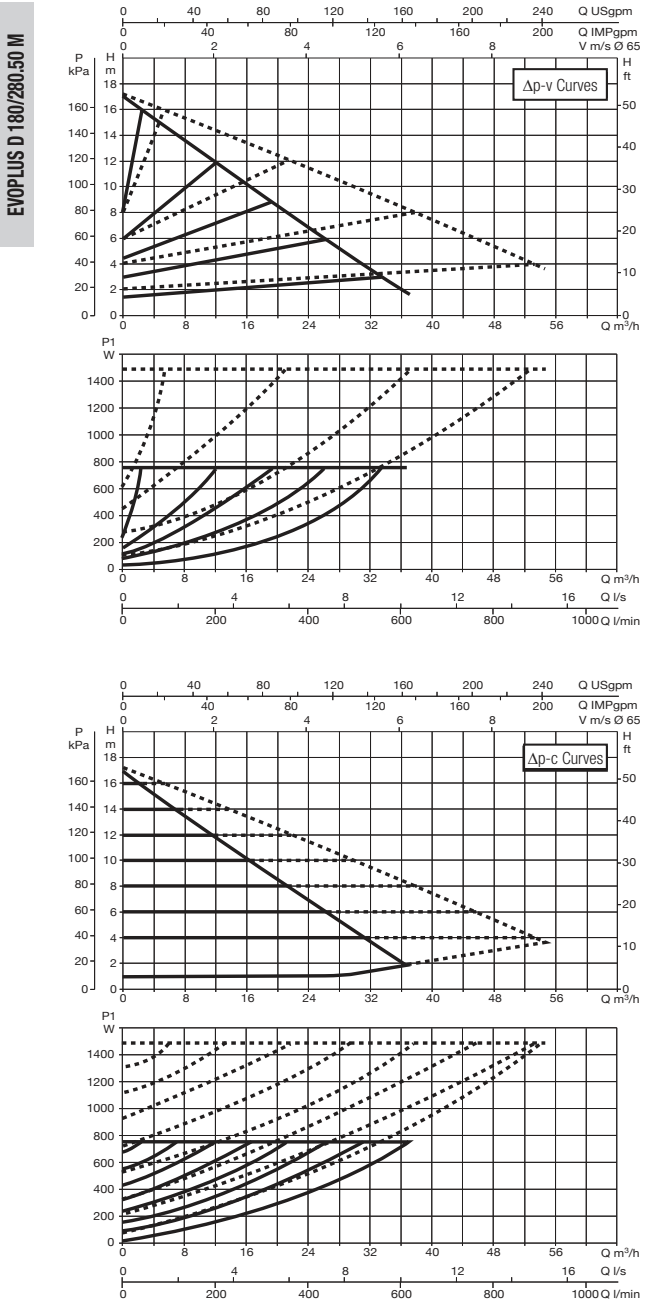
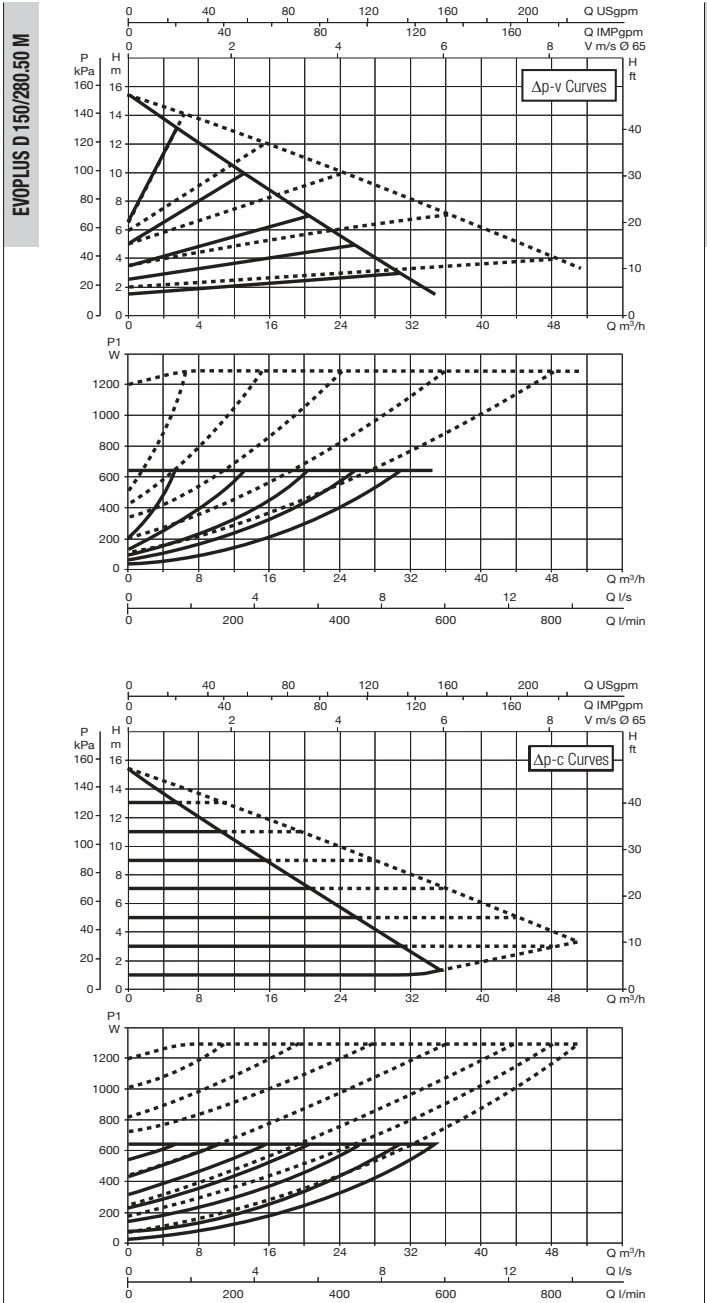

The curves are based on kinematic viscosity values = 1 mm²/s and density equal to 1000 kg/m³. Curve tolerance according to ISO 9906. Fixed speed curves available on the DNA.

MODEL	CENTRE DISTANCE mm	COUNTERFLANGES ON REQUEST	POWER INPUT 50/60 Hz	P1 MAX W	In A	EEI*	MINIMUM SUCTION PRESSURE			WEIGHT Kg
							t°	90°	100°	
EVOPLUS D 150/280.50 M	280	DN50 PN 10	220/240 V	640	3	EEI ≤ 0,21	m.c.w.	20	25	41,6
EVOPLUS D 180/280.50 M	280	DN50 PN 10	220/240 V	750	3,45	EEI ≤ 0,21	m.c.w.	20	25	41,6

* The parameter of reference for the more efficient circulators is EEI ≤ 0,20.

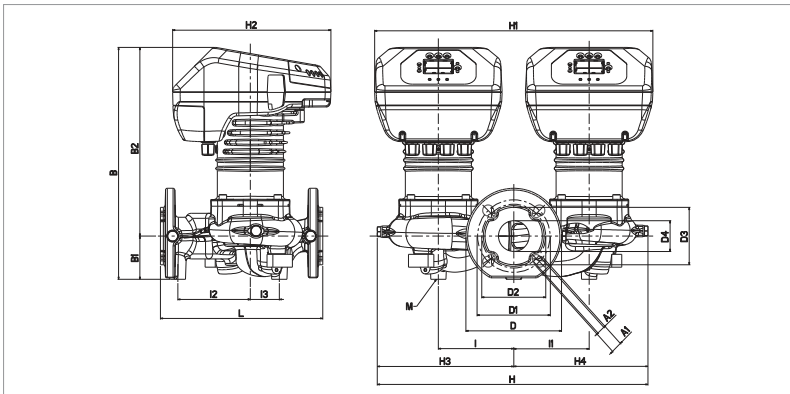

L	A1	A2	B	B1	B2	D	D1	D2	D3	D4
280	19	14	400	75	325	165	125	110	99	53

I	I1	I2	I3	M	H	H1	H2	H3	H4
130	130	125	50	M12	467	480	273	235	232

EVOPLUS - WET ROTOR ELECTRONIC CIRCULATORS

Pumped liquid temperature range: from -10 °C to +110 °C - Maximum operating pressure: 16 bar (1600 kPa)

EVOPLUS D 40/340.65 M

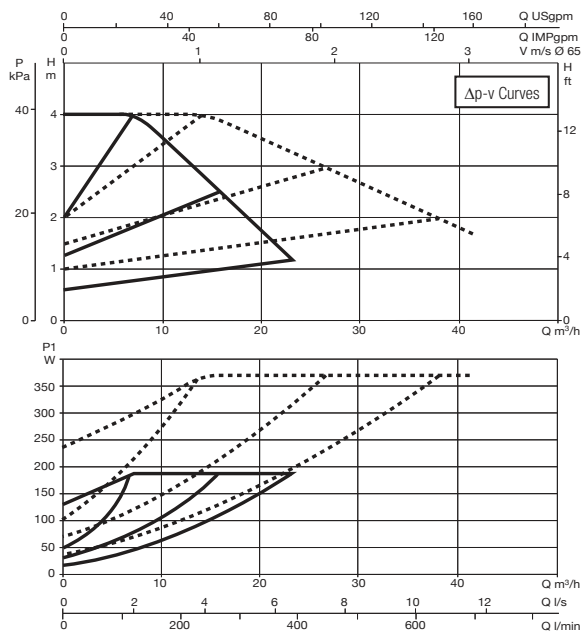

EVOPLUS D 60/340.65 M

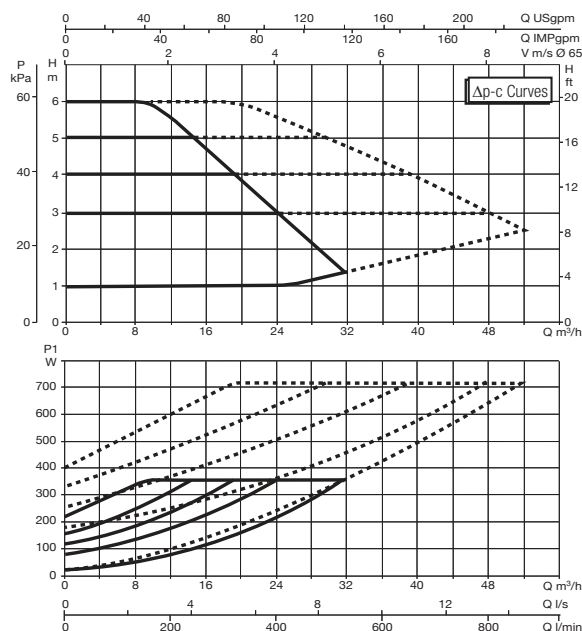
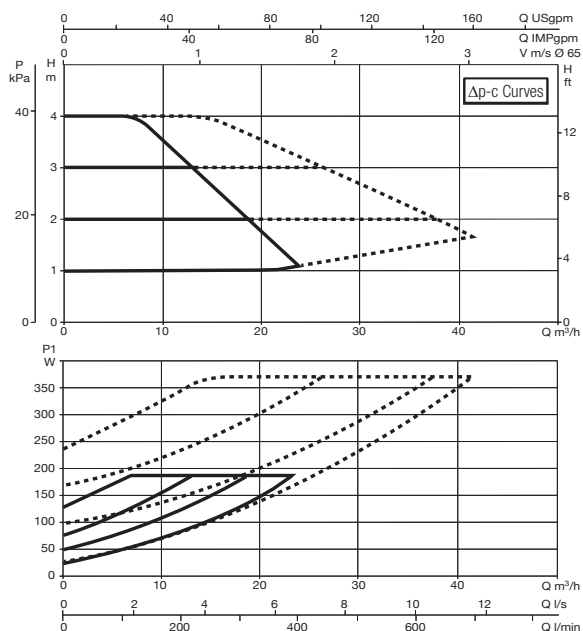
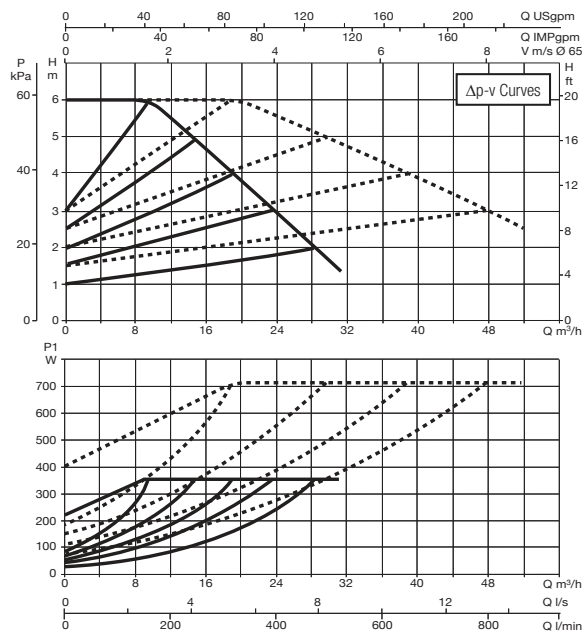

The curves are based on kinematic viscosity values = 1 mm²/s and density equal to 1000 kg/m³. Curve tolerance according to ISO 9906. Fixed speed curves available on the DNA.

MODEL	CENTRE DISTANCE mm	COUNTERFLANGES ON REQUEST	POWER INPUT 50/60 Hz	P1 MAX W	In A	EEI*	MINIMUM SUCTION PRESSURE			WEIGHT Kg
							t°	90°	100°	
EVOPLUS D 40/340.65 M	340	DN65 PN 10	220/240 V	190	1,1	EEI ≤ 0,21	m.c.w.	20	25	43,4
EVOPLUS D 60/340.65 M	340	DN65 PN 10	220/240 V	355	1,8	EEI ≤ 0,21	m.c.w.	20	25	43,4

* The parameter of reference for the more efficient circulators is EEI ≤ 0,20.

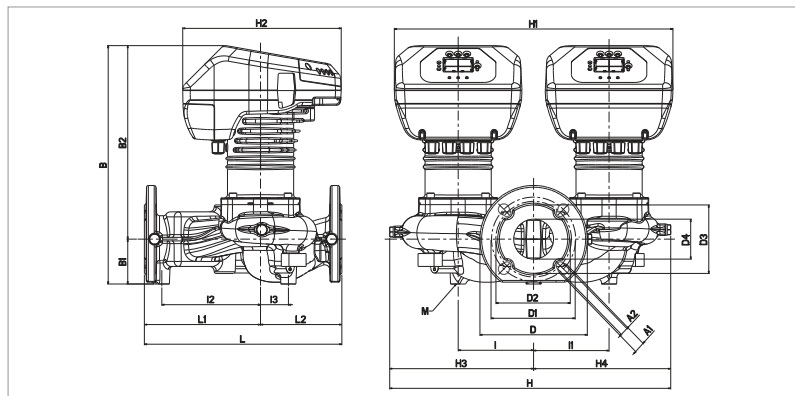

L	L1	L2	A1	A2	B	B1	B2	D	D1	D2	D3
340	200	140	19	14	411	77	334	185	145	130	118

D4	I	I1	I2	I3	M	H	H1	H2	H3	H4
69	130	130	170	48	M12	484	480	273	248	236

EVOPLUS - WET ROTOR ELECTRONIC CIRCULATORS

Pumped liquid temperature range: from -10 °C to +110°C - Maximum operating pressure: 16 bar (1600 kPa)

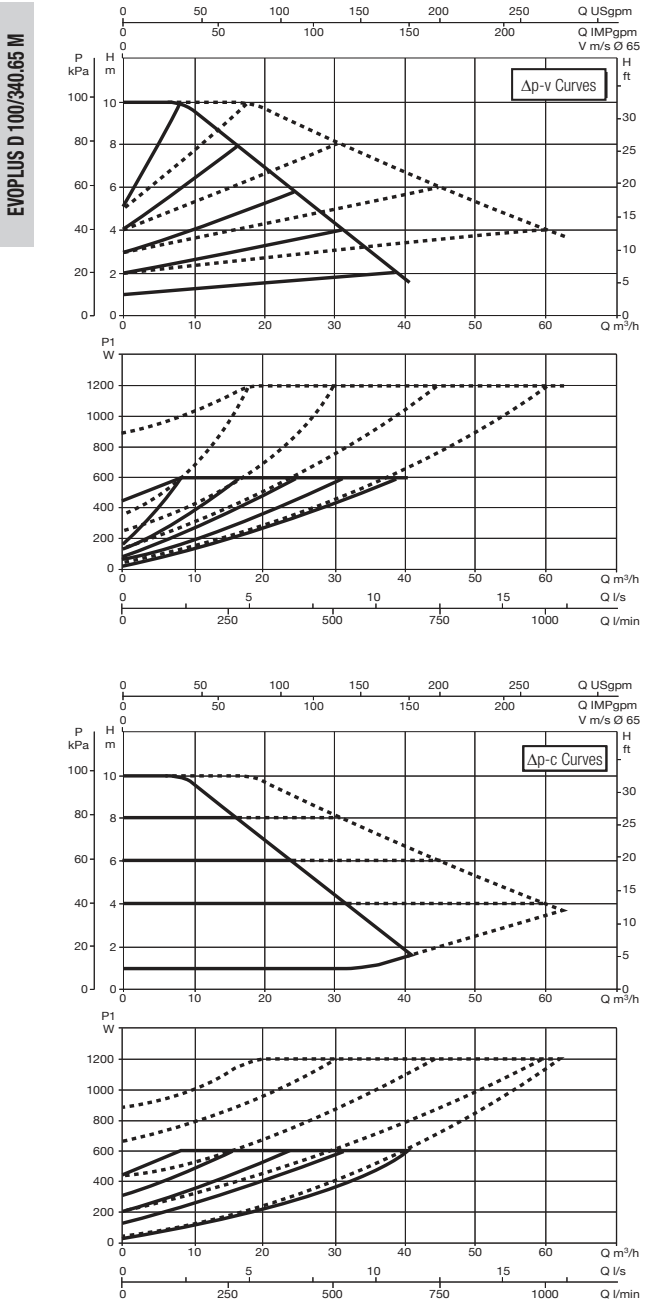
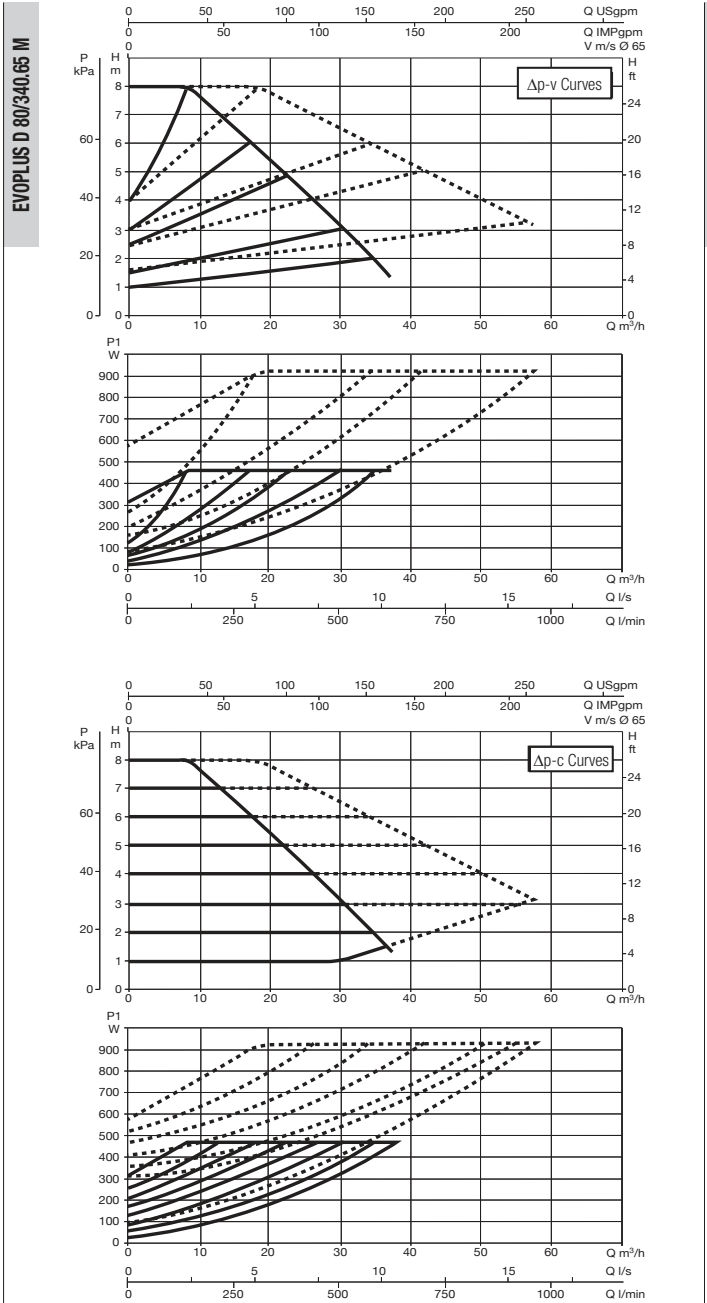

The curves are based on kinematic viscosity values = 1 mm²/s and density equal to 1000 kg/m³. Curve tolerance according to ISO 9906. Fixed speed curves available on the DNA.

MODEL	CENTRE DISTANCE mm	COUNTERFLANGES ON REQUEST	POWER INPUT 50/60 Hz	P1 MAX W	In A	EEI*	MINIMUM SUCTION PRESSURE			WEIGHT Kg
							t°	90°	100°	
EVOPLUS D 80/340.65 M	340	DN65 PN 10	220/240 V	465	2,2	EEI ≤ 0,21	m.c.w.	20	25	43,4
EVOPLUS D 100/340.65 M	340	DN65 PN 10	220/240 V	590	2,8	EEI ≤ 0,20	m.c.w.	20	25	44,8

* The parameter of reference for the more efficient circulators is EEI ≤ 0,20.

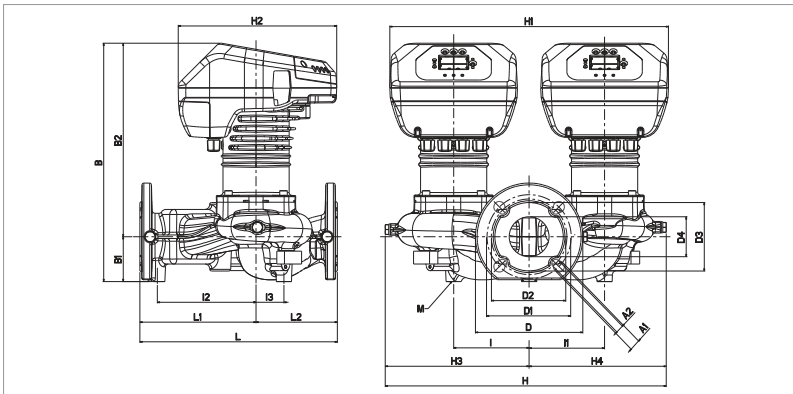

L	L1	L2	A1	A2	B	B1	B2	D	D1	D2	D3
340	200	140	19	14	411	77	334	185	145	130	118

D4	I	I1	I2	I3	M	H	H1	H2	H3	H4
69	130	130	170	48	M12	484	480	273	248	236



EVOPLUS - WET ROTOR ELECTRONIC CIRCULATORS

Pumped liquid temperature range: from -10 °C to +110 °C - Maximum operating pressure: 16 bar (1600 kPa)

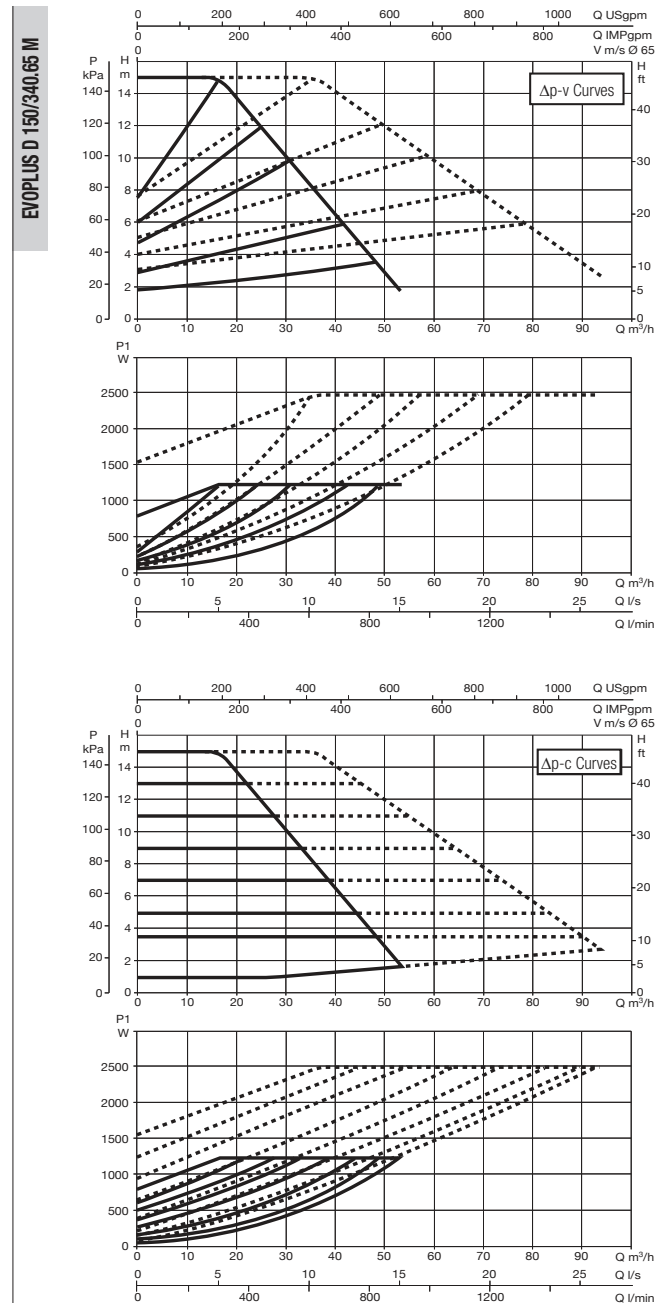
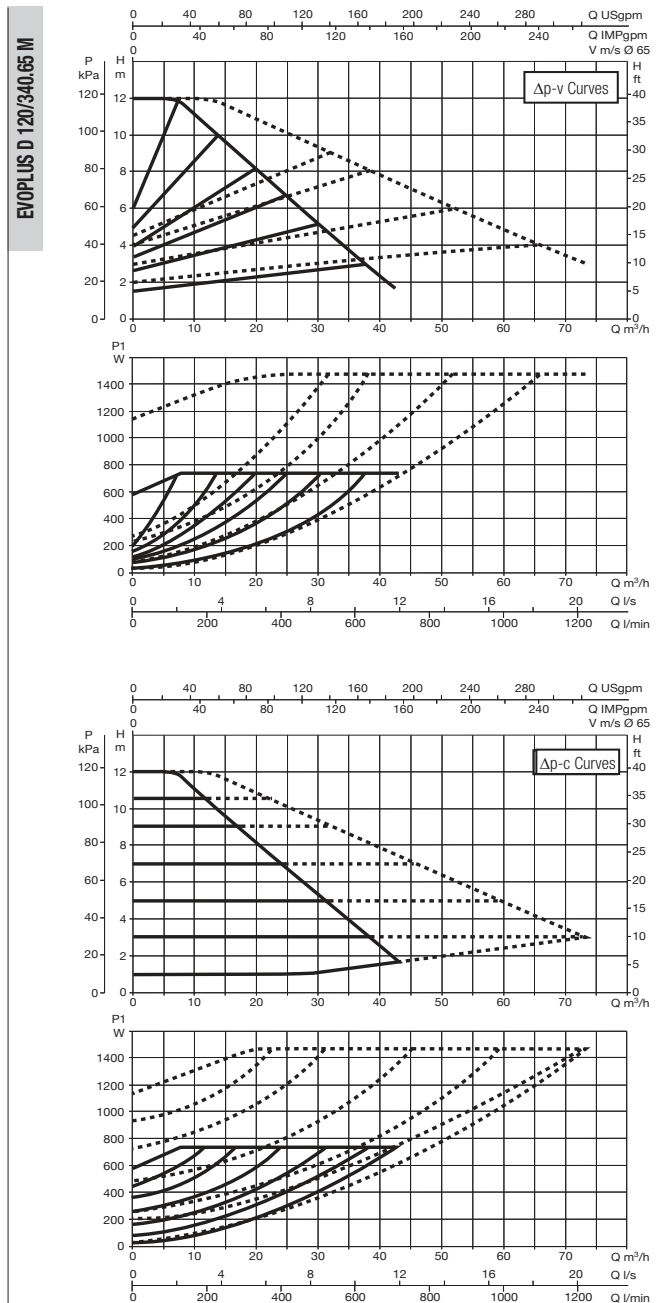

The curves are based on kinematic viscosity values = 1 mm²/s and density equal to 1000 kg/m³. Curve tolerance according to ISO 9906. Fixed speed curves available on the DNA.

MODEL	CENTRE DISTANCE mm	COUNTERFLANGES ON REQUEST	POWER INPUT 50/60 Hz	P1 MAX W	In A	EEI*	MINIMUM SUCTION PRESSURE			WEIGHT Kg
							t°	90°	100°	
EVOPLUS D 120/340.65 M	340	DN65 PN 10	220/240 V	730	3,45	EEI ≤ 0,20	m.c.w.	20	25	45
EVOPLUS D 150/340.65 M	340	DN65 PN 10	220/240 V	1210	5,5	EEI ≤ 0,20	m.c.w.	20	25	49,4

* The parameter of reference for the more efficient circulators is EEI ≤ 0,20.

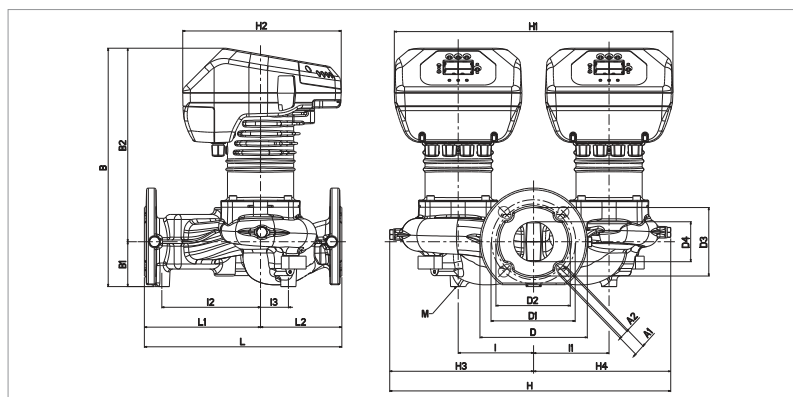

L	L1	L2	A1	A2	B	B1	B2	D	D1	D2	D3
340	200	140	19	14	411	77	334	185	145	130	118

D4	I	I1	I2	I3	M	H	H1	H2	H3	H4
69	130	130	170	48	M12	484	480	273	248	236

EVOPLUS - WET ROTOR ELECTRONIC CIRCULATORS

Pumped liquid temperature range: from -10 °C to +110 °C - Maximum operating pressure: 16 bar (1600 kPa)

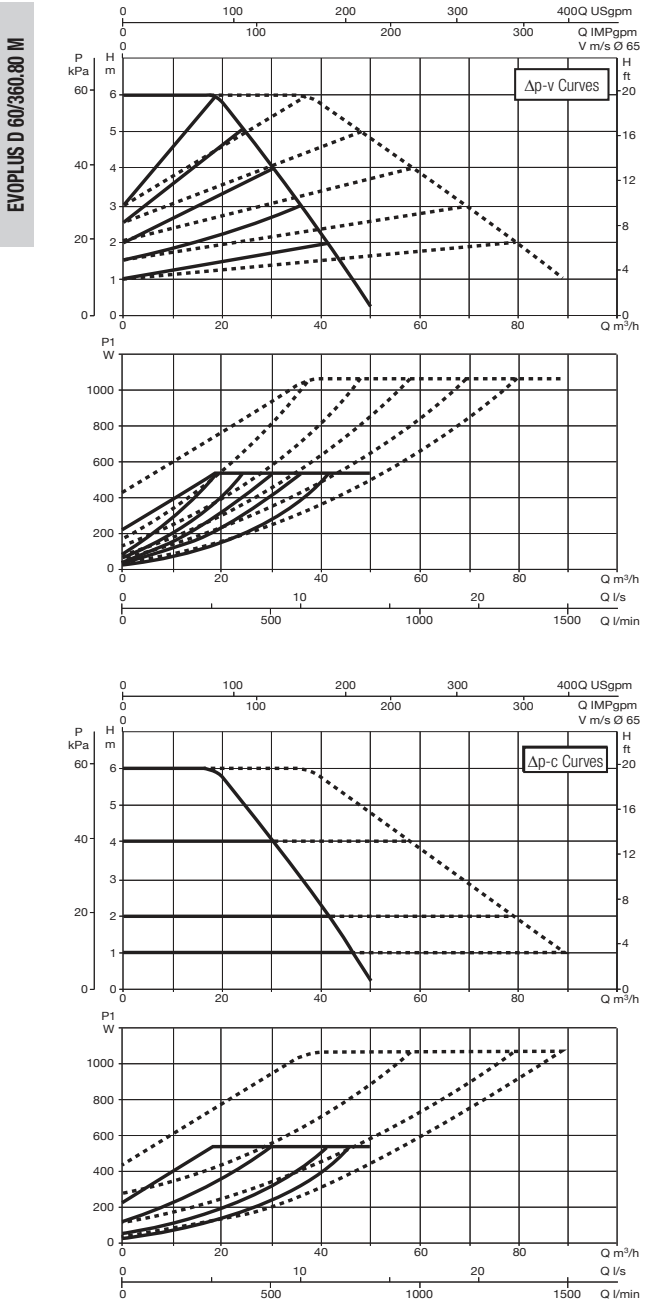
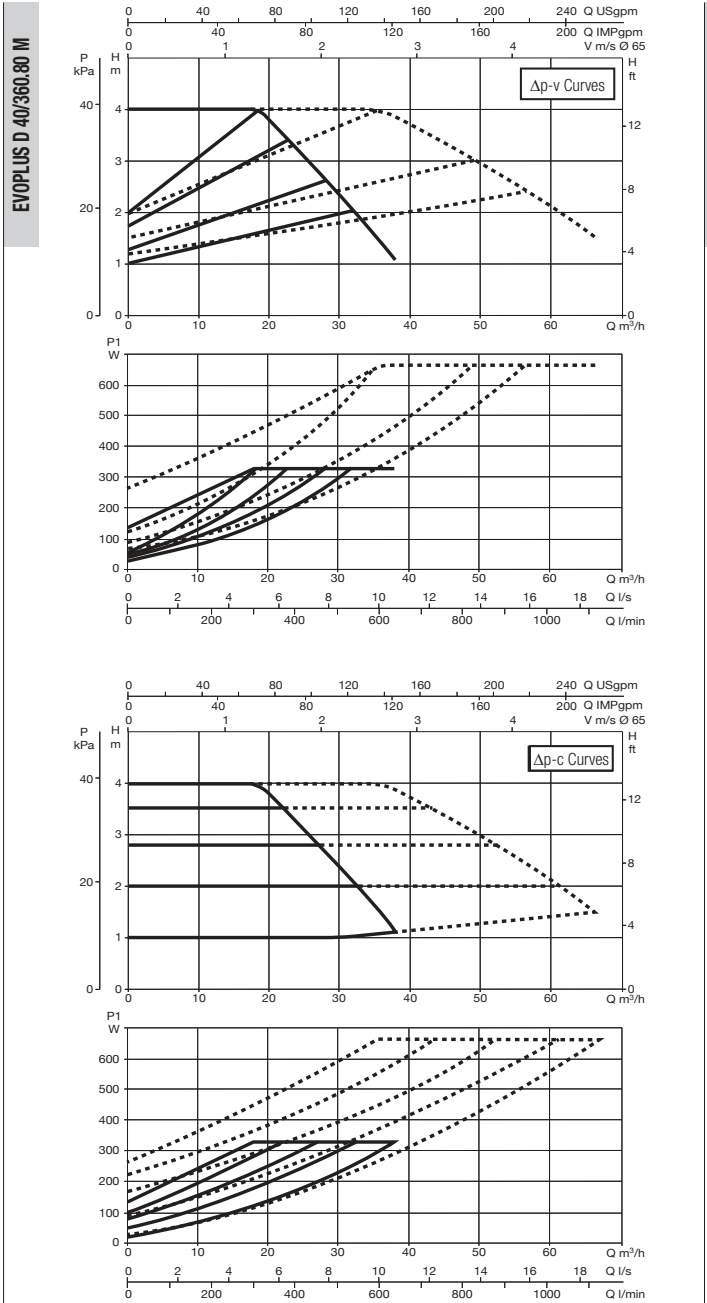

The curves are based on kinematic viscosity values = 1 mm²/s and density equal to 1000 kg/m³. Curve tolerance according to ISO 9906. Fixed speed curves available on the DNA.

MODEL	CENTRE DISTANCE mm	COUNTERFLANGES ON REQUEST	POWER INPUT 50/60 Hz	P1 MAX W	In A	EEI*	MINIMUM SUCTION PRESSURE			WEIGHT Kg
							t°	90°	100°	
EVOPLUS D 40/360.80 M	360	DN80 PN 10	220/240 V	330	1,65	EEI ≤ 0,20	m.c.w.	20	25	52
EVOPLUS D 60/360.80 M	360	DN80 PN 10	220/240 V	535	2,5	EEI ≤ 0,20	m.c.w.	20	25	52

* The parameter of reference for the more efficient circulators is EEI ≤ 0,20.

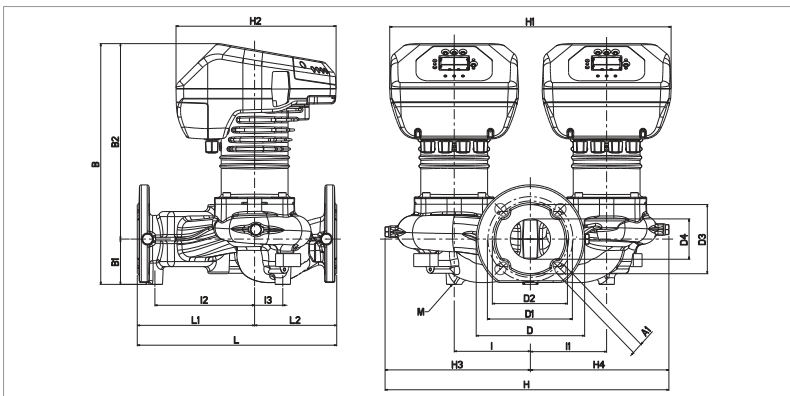

L	L1	L2	A1	B	B1	B2	D	D1	D3	D4
360	200	160	19	437	96	341	200	160	132	80

I	I1	I2	I3	M	H	H1	H2	H3	H4
130	130	160	58	M12	515	480	273	262	253

EVOPLUS - WET ROTOR ELECTRONIC CIRCULATORS

Pumped liquid temperature range: from -10 °C to +110 °C - Maximum operating pressure: 16 bar (1600 kPa)

EVOPLUS D 80/360.80 M

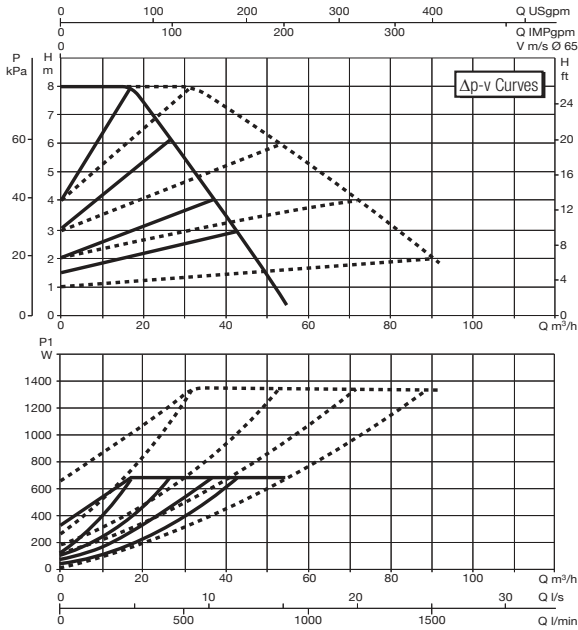

EVOPLUS D 100/360.80 M

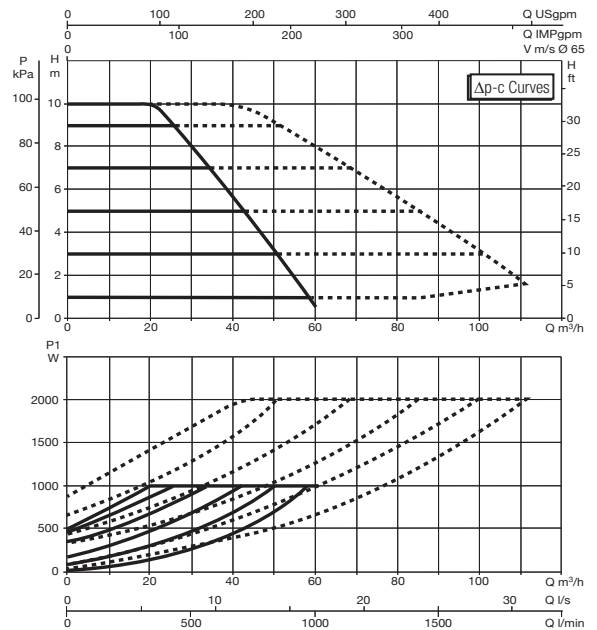
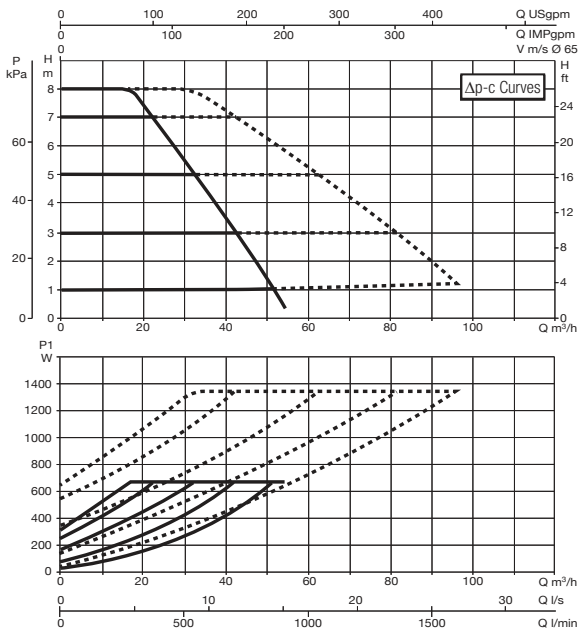
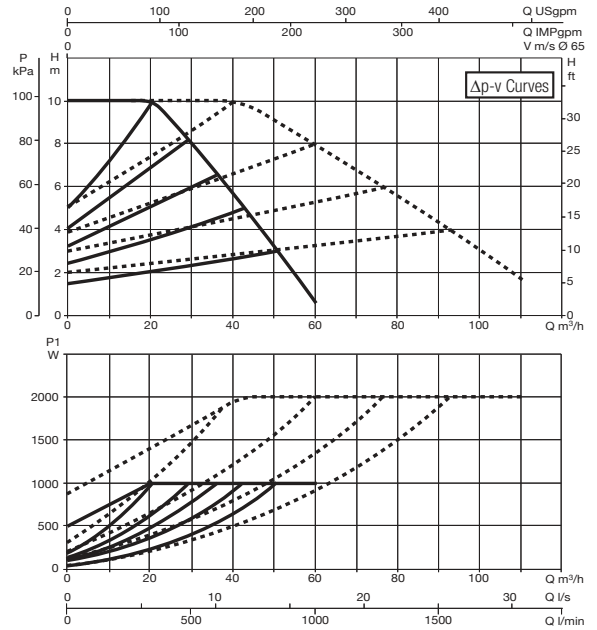

The curves are based on kinematic viscosity values = 1 mm²/s and density equal to 1000 kg/m³. Curve tolerance according to ISO 9906. Fixed speed curves available on the DNA.

MODEL	CENTRE DISTANCE mm	COUNTERFLANGES ON REQUEST	POWER INPUT 50/60 Hz	P1 MAX W	In A	EEI*	MINIMUM SUCTION PRESSURE			PESO Kg
							t°	90°	100°	
EVOPLUS D 80/360.80 M	360	DN80 PN 10	220/240 V	670	3	EEI ≤ 0,20	m.c.w.	20	25	57
EVOPLUS D 100/360.80 M	360	DN80 PN 10	220/240 V	1005	4,5	EEI ≤ 0,19	m.c.w.	20	25	56

* The parameter of reference for the more efficient circulators is EEI ≤ 0,20.

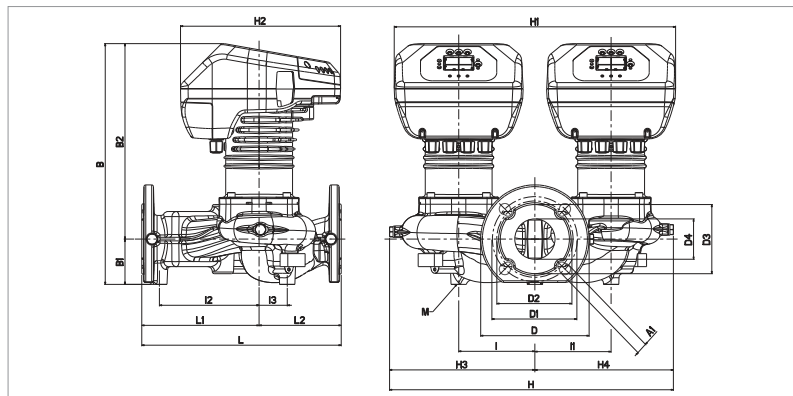

L	L1	L2	A1	B	B1	B2	D	D1	D3	D4
360	200	160	19	437	96	341	200	160	132	80

I	I1	I2	I3	M	H	H1	H2	H3	H4
130	130	160	58	M12	515	480	273	262	253

EVOPLUS - WET ROTOR ELECTRONIC CIRCULATORS

Pumped liquid temperature range: from -10 °C to +110 °C - Maximum operating pressure: 16 bar (1600 kPa)

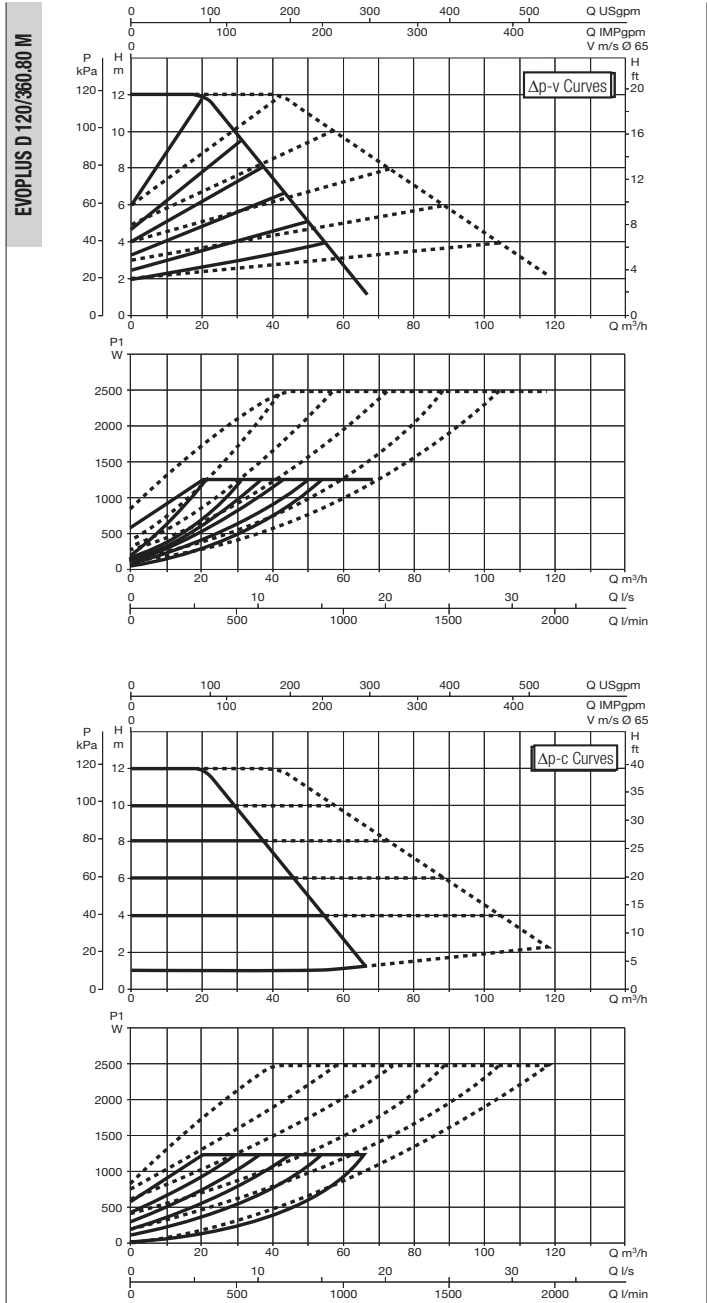

The curves are based on kinematic viscosity values = 1 mm²/s and density equal to 1000 kg/m³. Curve tolerance according to ISO 9906. Fixed speed curves available on the DNA.

MODEL	CENTRE DISTANCE mm	COUNTERFLANGES ON REQUEST	POWER INPUT 50/60 Hz	P1 MAX W	In A	EEI*	MINIMUM SUCTION PRESSURE			WEIGHT Kg
							t°	90°	100°	
EVOPLUS D 120/360.80 M	360	DN80 PN 10	220/240 V	1235	5,5	EEI ≤ 0,19	m.c.w.	20	25	56,4

* The parameter of reference for the more efficient circulators is EEI ≤ 0,20.

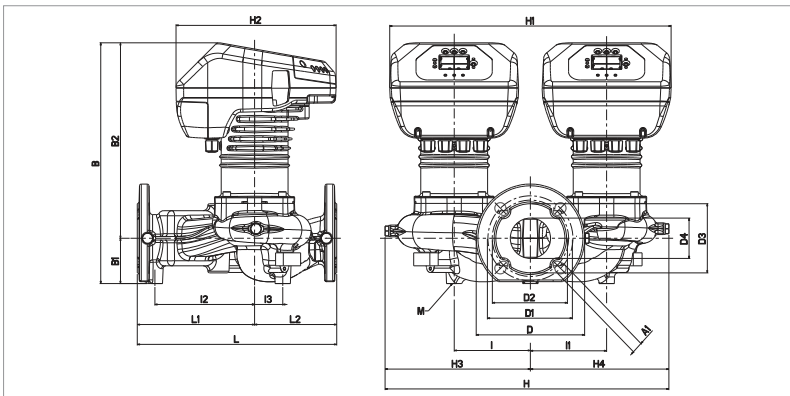

L	L1	L2	A1	B	B1	B2	D	D1	D3	D4
360	200	160	19	437	96	341	200	160	132	80

I	I1	I2	I3	M	H	H1	H2	H3	H4
130	130	160	58	M12	515	480	273	262	253

EVOPLUS - WET ROTOR ELECTRONIC CIRCULATORS

Pumped liquid temperature range: from -10 °C to +110 °C - Maximum operating pressure: 16 bar (1600 kPa)

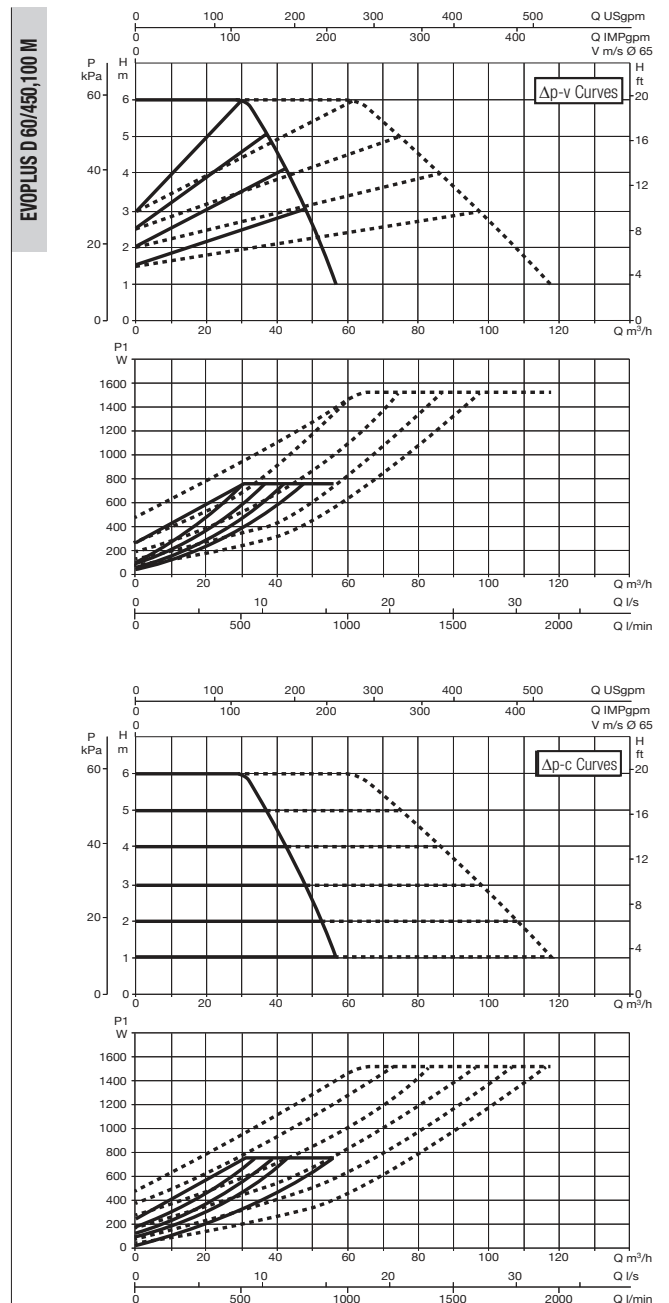
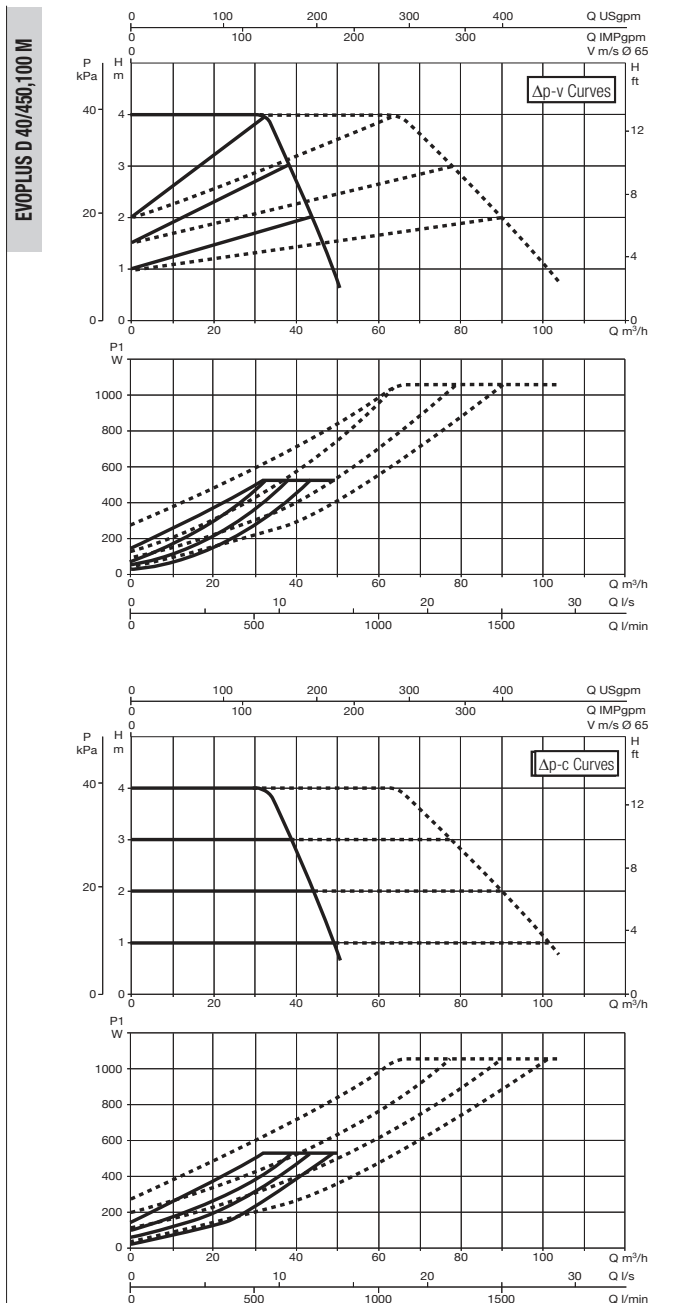

The curves are based on kinematic viscosity values = 1 mm²/s and density equal to 1000 kg/m³. Curve tolerance according to ISO 9906. Fixed speed curves available on the DNA.

MODEL	CENTRE DISTANCE mm	COUNTERFLANGES ON REQUEST	POWER INPUT 50/60 Hz	P1 MAX W	In A	EEI*	MINIMUM SUCTION PRESSURE			WEIGHT Kg
							t°	90°	100°	
EVOPLUS D 40/450.100 M	450	DN100 PN 10	220/240 V	530	2,5	EEI ≤ 0,19	m.c.w.	20	25	67,8
EVOPLUS D 60/450.100 M	450	DN100 PN 10	220/240 V	760	3,5	EEI ≤ 0,19	m.c.w.	20	25	67,8

* The parameter of reference for the more efficient circulators is EEI ≤ 0,20.

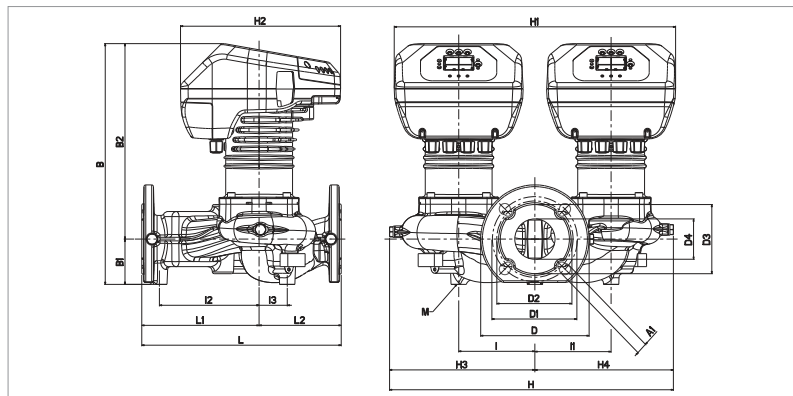

L	L1	L2	A1	B	B1	B2	D	D1	D3	D4
450	260	190	19	456	103	353	220	180	156	105

I	I1	I2	I3	M	H	H1	H2	H3	H4
135	135	200	43	12	517	490	273	265	252

EVOPLUS - WET ROTOR ELECTRONIC CIRCULATORS

Pumped liquid temperature range: from -10 °C to +110 °C - Maximum operating pressure: 16 bar (1600 kPa)

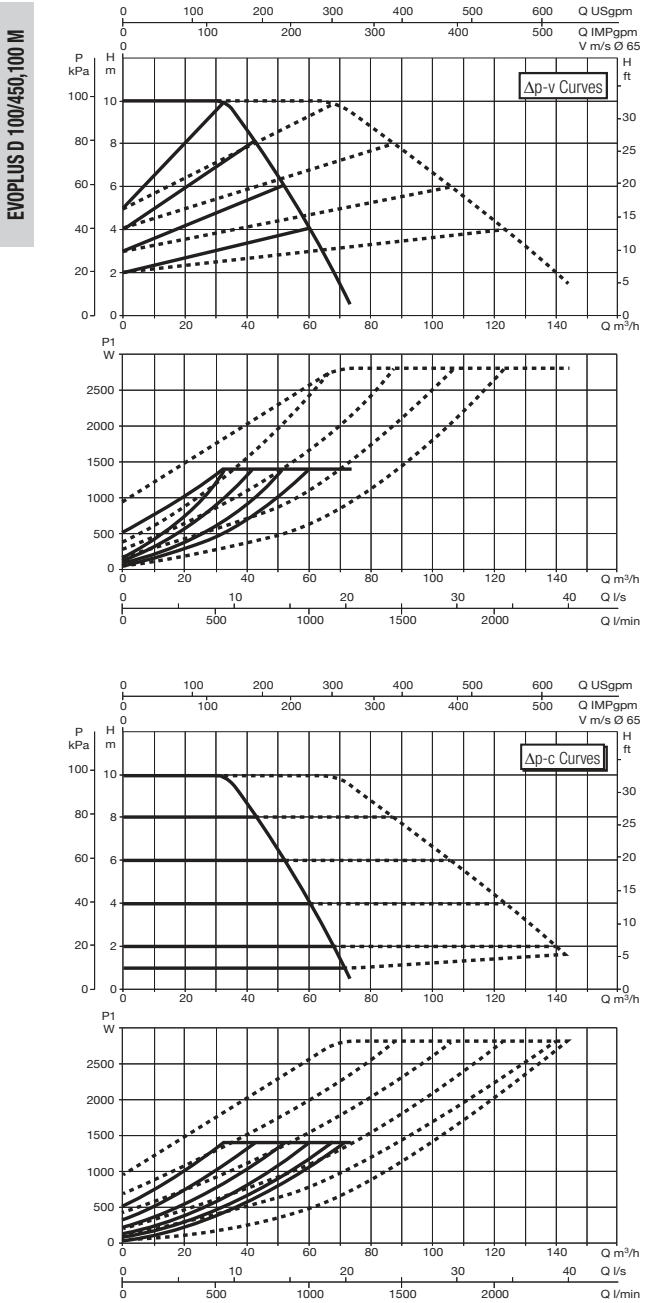
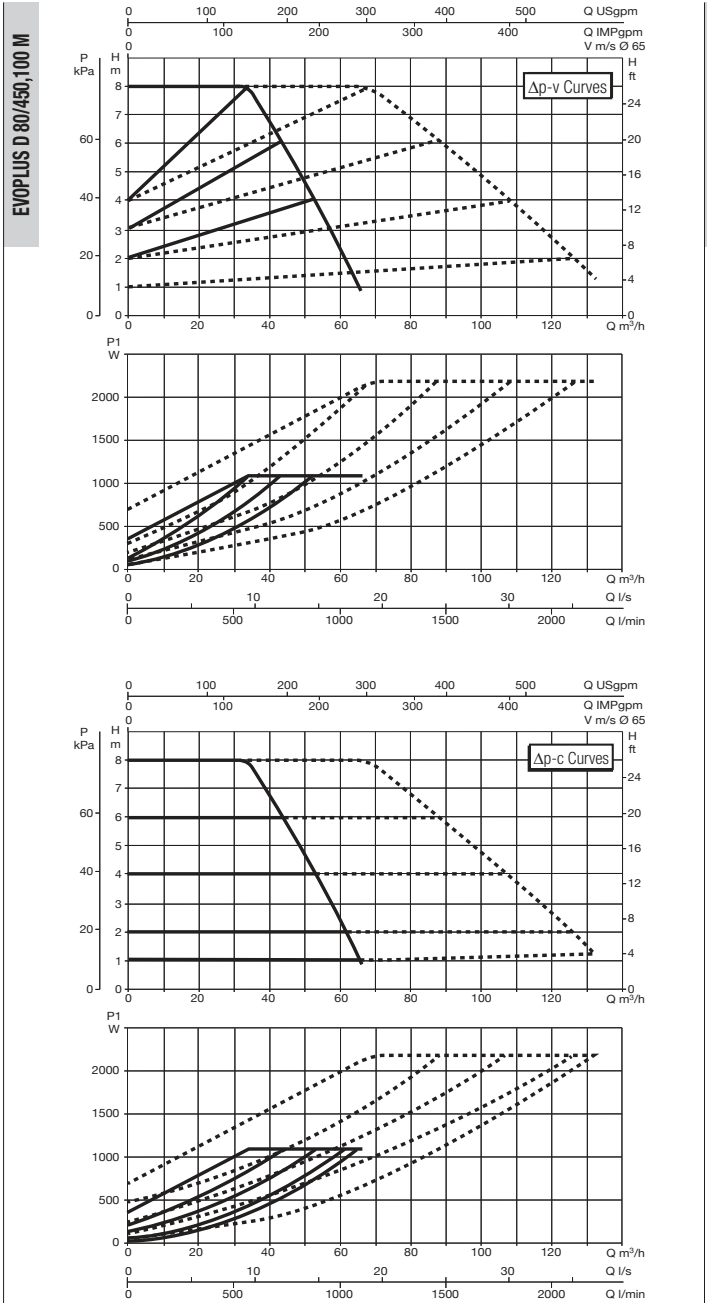

The curves are based on kinematic viscosity values = 1 mm²/s and density equal to 1000 kg/m³. Curve tolerance according to ISO 9906. Fixed speed curves available on the DNA.

MODEL	CENTRE DISTANCE mm	COUNTERFLANGES ON REQUEST	POWER INPUT 50/60 Hz	P1 MAX W	In A	EEI*	MINIMUM SUCTION PRESSURE			WEIGHT Kg
							t°	90°	100°	
EVOPLUS D 80/450.100 M	450	DN100 PN 10	220/240 V	1080	4,8	EEI ≤ 0,20	m.c.w.	20	25	68
EVOPLUS D 100/450.100 M	450	DN100 PN 10	220/240 V	1380	6	EEI ≤ 0,20	m.c.w.	20	25	68

* The parameter of reference for the more efficient circulators is EEI ≤ 0,20.

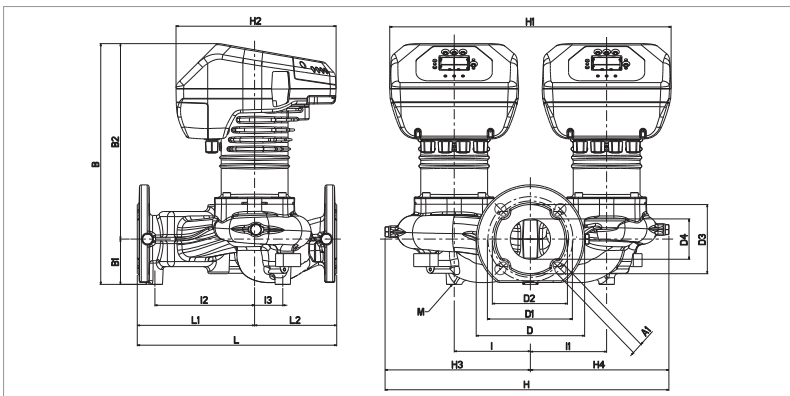

L	L1	L2	A1	B	B1	B2	D	D1	D3	D4
450	260	190	19	456	103	353	220	180	156	105

I	I1	I2	I3	M	H	H1	H2	H3	H4
135	135	200	43	12	517	490	273	265	252

EVOPLUS – WET ROTOR ELECTRONIC CIRCULATORS

Pumped liquid temperature range: from -10 °C to +110 °C - Maximum operating pressure: 16 bar (1600 kPa)

EVOPLUS D 120/450,100 M

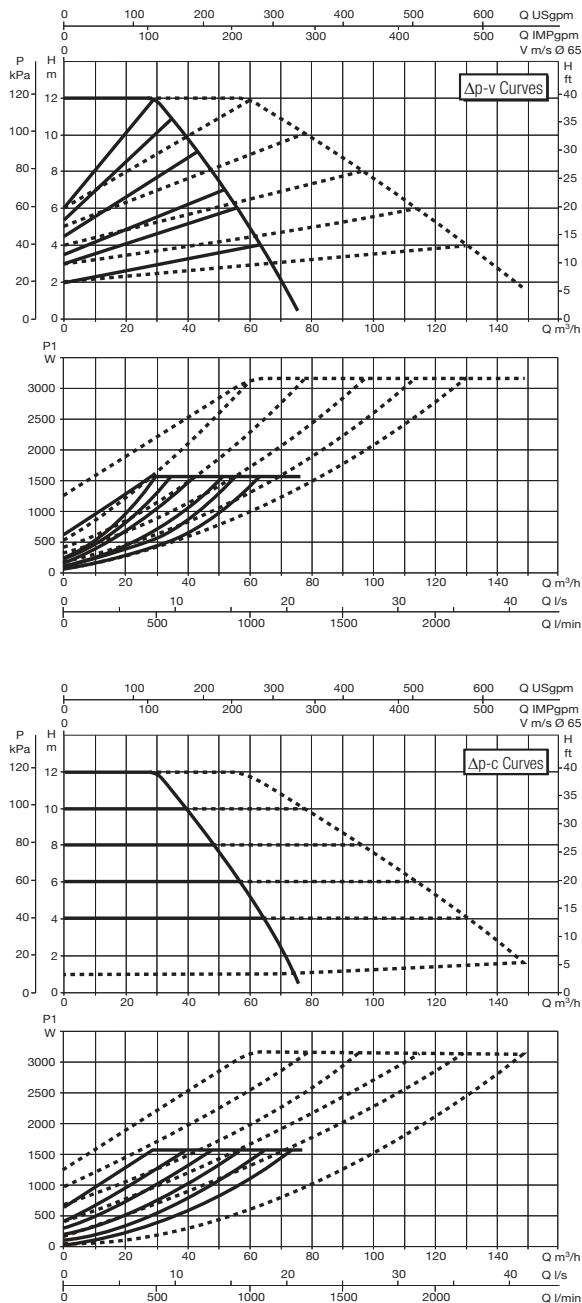

The curves are based on kinematic viscosity values = 1 mm²/s and density equal to 1000 kg/m³. Curve tolerance according to ISO 9906. Fixed speed curves available on the DNA.

MODEL	CENTRE DISTANCE mm	COUNTERFLANGES ON REQUEST	POWER INPUT 50/60 Hz	P1 MAX W	In A	EEI*	MINIMUM SUCTION PRESSURE			WEIGHT Kg
							t°	90°	100°	
EVOPLUS D 120/450.100 M	450	DN100 PN 10	220/240 V	1560	7	EEI ≤ 0,20	m.c.w.	20	25	67,8

* The parameter of reference for the more efficient circulators is EEI ≤ 0,20.

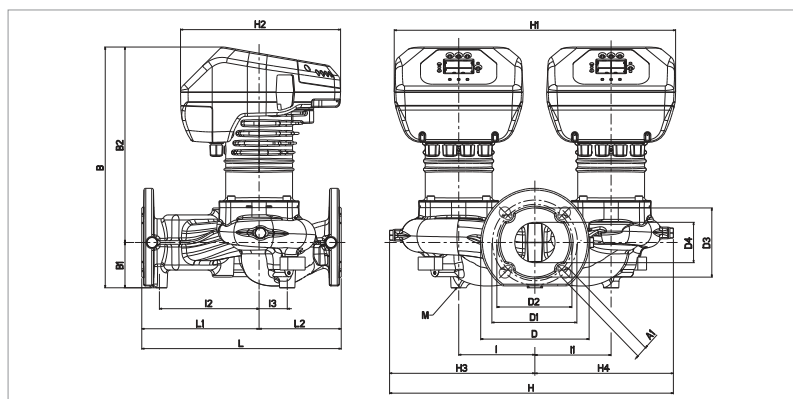

L	L1	L2	A1	B	B1	B2	D	D1	D3	D4
450	260	190	19	456	103	353	220	180	156	105

I	I1	I2	I3	M	H	H1	H2	H3	H4
135	135	200	43	12	517	490	273	265	252

EVOPLUS SAN - WET ROTOR ELECTRONIC CIRCULATORS

Pumped liquid temperature range: from -10 °C to +110 °C - Maximum operating pressure: 16 bar (1600 kPa)

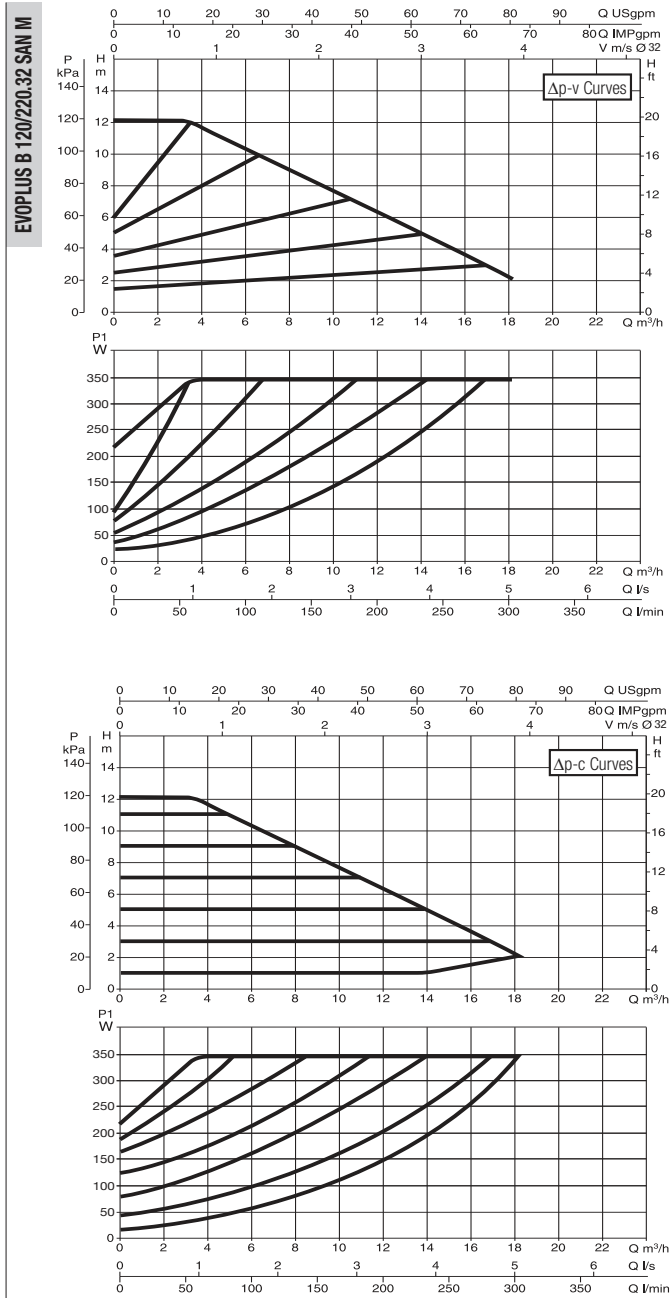

The curves are based on kinematic viscosity values = 1 mm²/s and density equal to 1000 kg/m³. Curve tolerance according to ISO 9906. Fixed speed curves available on the DNA.

MODEL	CENTRE DISTANCE mm	COUNTERFLANGES ON REQUEST	POWER INPUT 50/60 Hz	P1 MAX W	In A	MINIMUM SUCTION PRESSURE			WEIGHT Kg
						t°	90°	100°	
EVOPLUS B 120/220.32 SAN M	220	DN 32 PN 6	220/240 V	340	1,7	m.c.w.	20	25	24

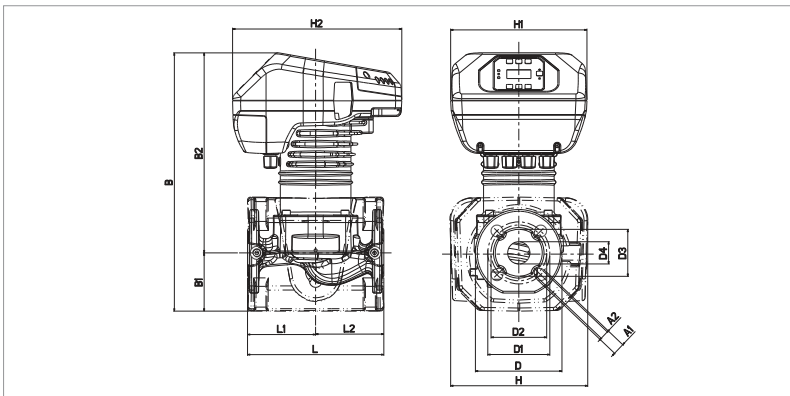

L	L1	L2	A1	A2	B	B1	B2
220	110	110	19	14	417	94	323

D	D1	D2	D3	D4	H	H1	H2
140	100	90	76	36	222	220	273

EVOPLUS SAN - WET ROTOR ELECTRONIC CIRCULATORS

Pumped liquid temperature range: from -10 °C to +110 °C - Maximum operating pressure: 16 bar (1600 kPa)

EVOPLUS B 120/250.40 SAN M

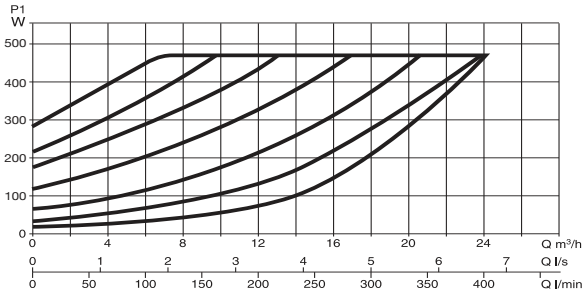
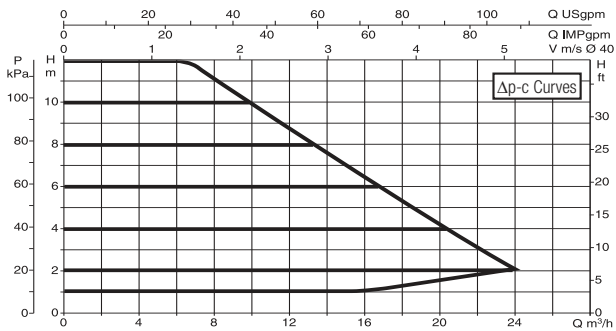
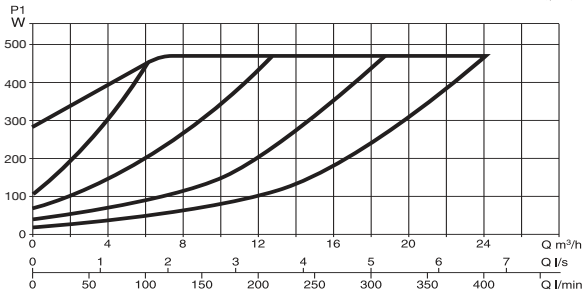
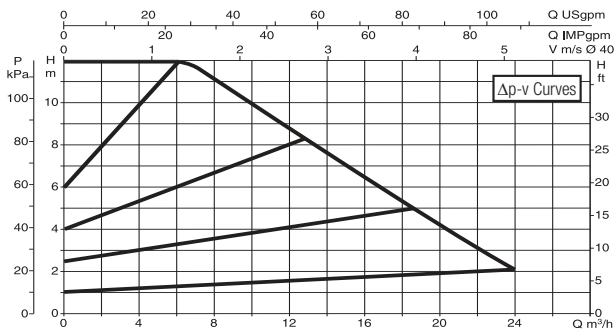

EVOPLUS B 150/250.40 SAN M

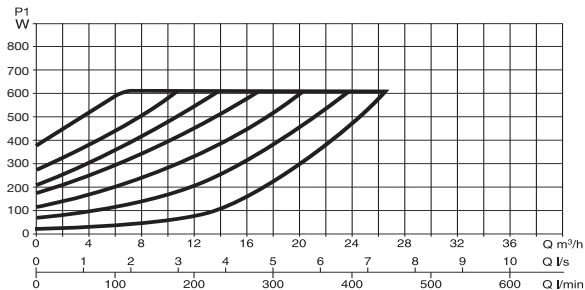
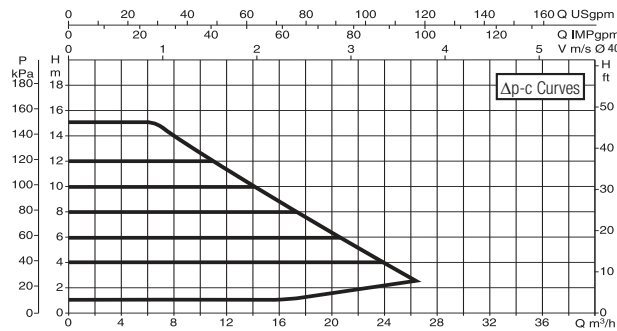
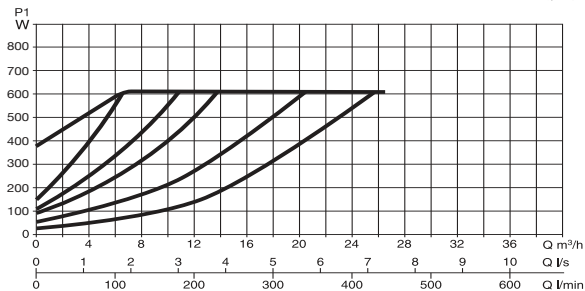
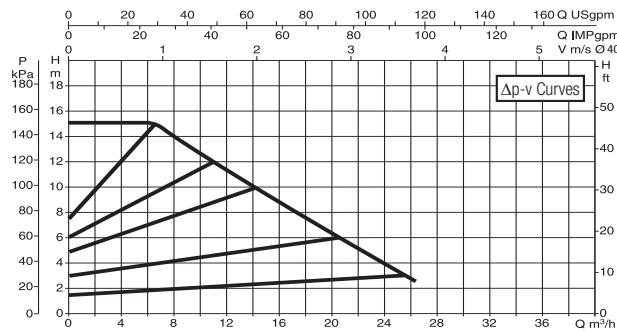

The curves are based on kinematic viscosity values = 1 mm²/s and density equal to 1000 kg/m³. Curve tolerance according to ISO 9906. Fixed speed curves available on the DNA.

MODEL	CENTRE DISTANCE mm	COUNTERFLANGES ON REQUEST	POWER INPUT 50/60 Hz	P1 MAX W	In A	MINIMUM SUCTION PRESSURE			WEIGHT Kg
						t°	90°	100°	
EVOPLUS B 120/250.40 SAN M	250	DN 40 PN 10	220/240 V	465	2,2	m.c.w.	20	25	22
EVOPLUS B 150/250.40 SAN M	250	DN 40 PN 10	220/240 V	610	2,9	m.c.w.	20	25	20

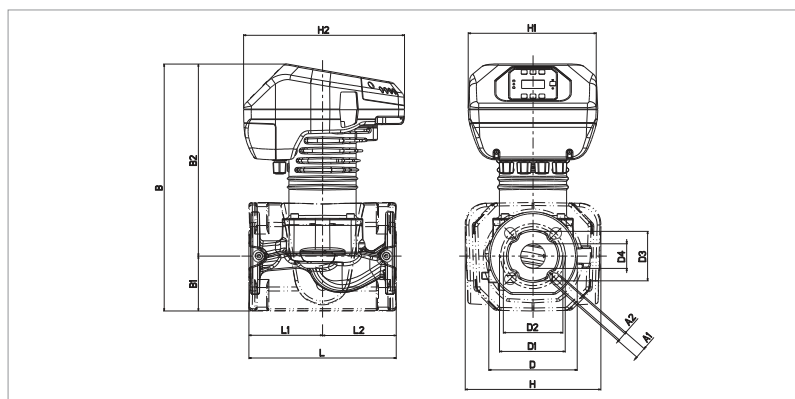

L	L1	L2	A1	A2	B	B1	B2
250	125	125	19	14	419	93	326

D	D1	D2	D3	D4	H	H1	H2
150	110	100	84	42	230	220	273

EVOPLUS SAN - WET ROTOR ELECTRONIC CIRCULATORS

Pumped liquid temperature range: from -10 °C to +110 °C - Maximum operating pressure: 16 bar (1600 kPa)

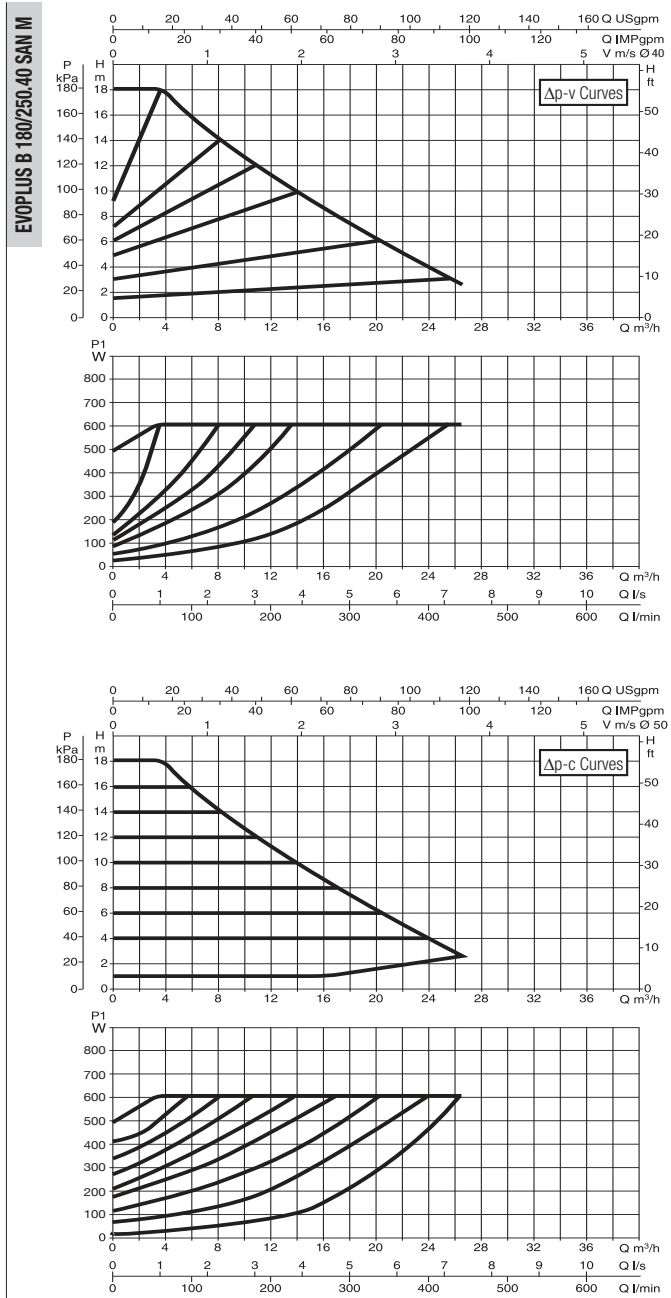

The curves are based on kinematic viscosity values = 1 mm²/s and density equal to 1000 kg/m³. Curve tolerance according to ISO 9906. Fixed speed curves available on the DNA.

MODEL	CENTRE DISTANCE mm	COUNTERFLANGES ON REQUEST	POWER INPUT 50/60 Hz	P1 MAX W	In A	MINIMUM SUCTION PRESSURE			WEIGHT Kg
						t°	90°	100°	
EVOPLUS B 180/250.40 SAN M	250	DN 40 PN 10	220/240 V	610	2,9	m.c.w.	20	25	20

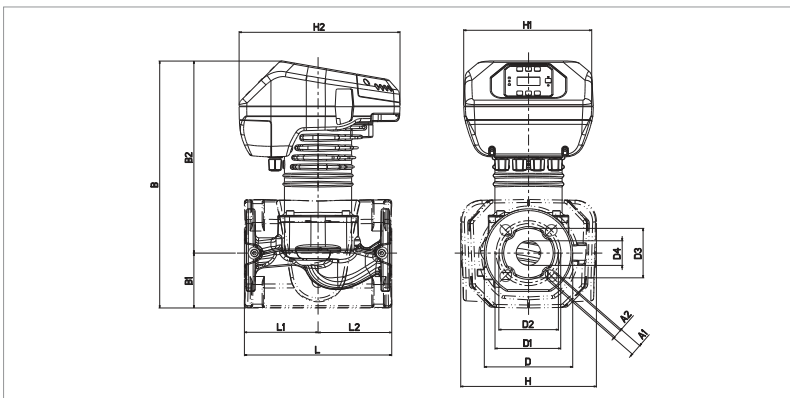

L	L1	L2	A1	A2	B	B1	B2
250	125	125	19	14	419	93	326

D	D1	D2	D3	D4	H	H1	H2
150	110	100	84	42	230	220	273

EVOPLUS SAN - WET ROTOR ELECTRONIC CIRCULATORS

Pumped liquid temperature range: from -10 °C to +110 °C - Maximum operating pressure: 16 bar (1600 kPa)

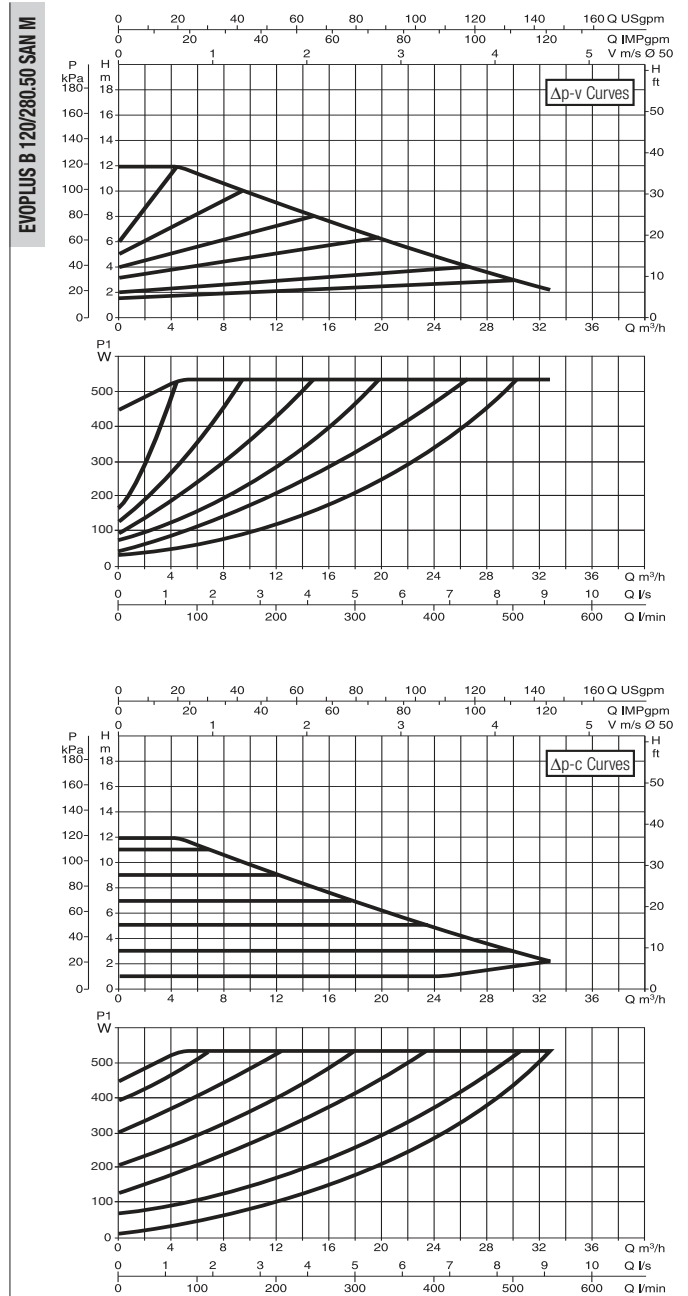
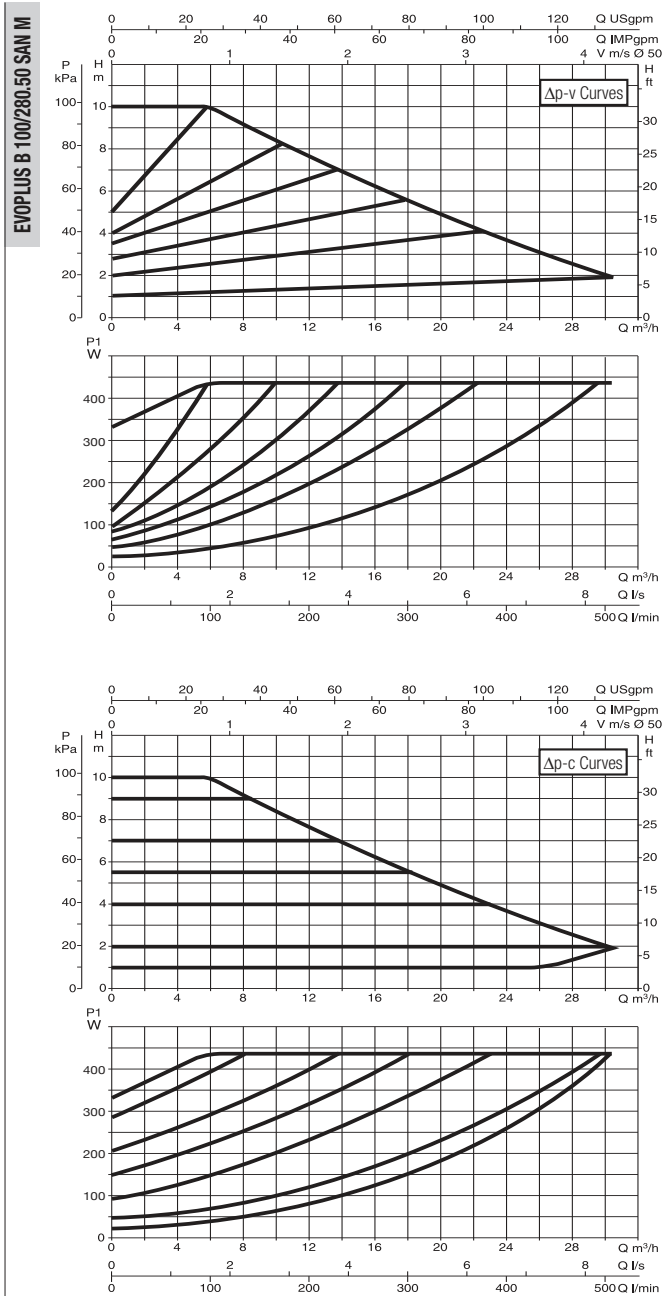

The curves are based on kinematic viscosity values = 1 mm²/s and density equal to 1000 kg/m³. Curve tolerance according to ISO 9906. Fixed speed curves available on the DNA.

MODEL	CENTRE DISTANCE mm	COUNTERFLANGES ON REQUEST	POWER INPUT 50/60 Hz	P1 MAX W	In A	MINIMUM SUCTION PRESSURE			WEIGHT Kg
						t°	90°	100°	
EVOPLUS B 100/280.50 SAN M	280	DN 50 PN 10	220/240 V	430	2,1	m.c.w.	20	25	22
EVOPLUS B 120/280.50 SAN M	280	DN 50 PN 10	220/240 V	530	2,5	m.c.w.	20	25	21,8

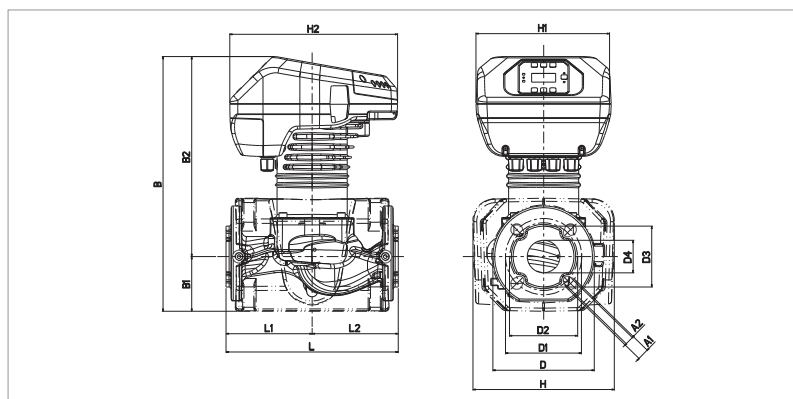

L	L1	L2	A1	A2	B	B1	B2
280	140	140	19	14	413	87	325

D	D1	D2	D3	D4	H	H1	H2
165	125	110	99	53	230	220	273

EVOPLUS SAN - WET ROTOR ELECTRONIC CIRCULATORS

Pumped liquid temperature range: from -10 °C to +110 °C - Maximum operating pressure: 16 bar (1600 kPa)

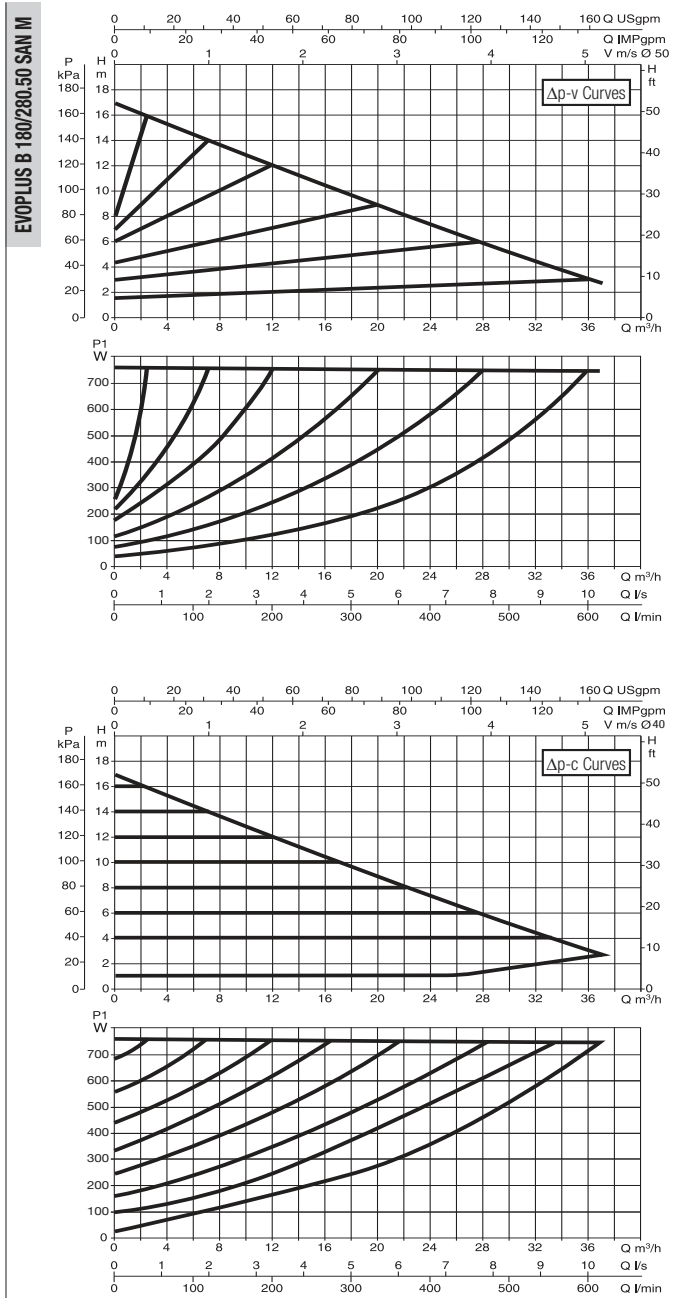
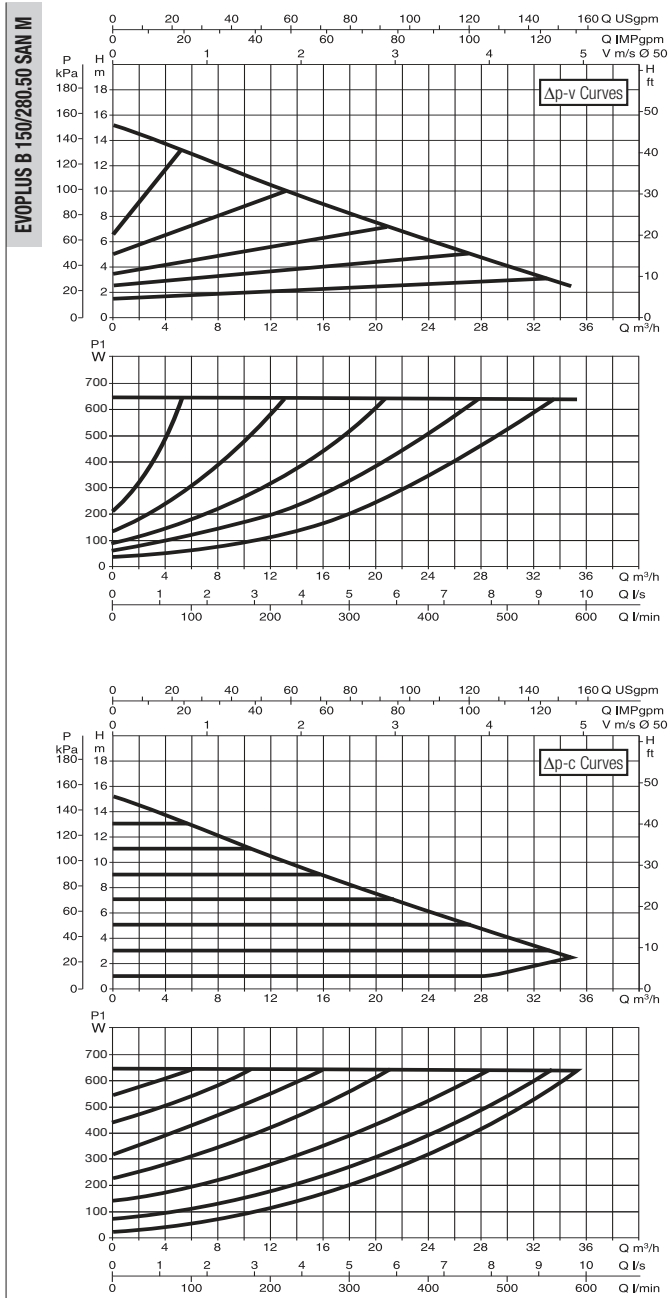

The curves are based on kinematic viscosity values = 1 mm²/s and density equal to 1000 kg/m³. Curve tolerance according to ISO 9906. Fixed speed curves available on the DNA.

MODEL	CENTRE DISTANCE mm	COUNTERFLANGES ON REQUEST	POWER INPUT 50/60 Hz	P1 MAX W	In A	MINIMUM SUCTION PRESSURE			WEIGHT Kg
						t°	90°	100°	
EVOPLUS B 150/280.50 SAN M	280	DN 50 PN 10	220/240 V	640	3	m.c.w.	20	25	22,8
EVOPLUS B 180/280.50 SAN M	280	DN 50 PN 10	220/240 V	750	3,45	m.c.w.	20	25	22,8

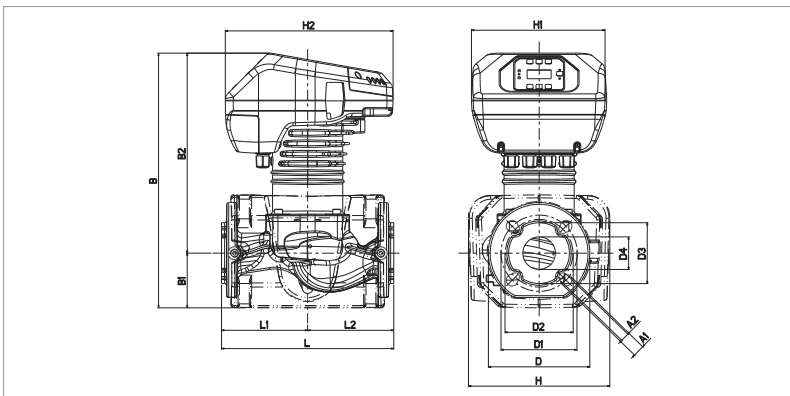

L	L1	L2	A1	A2	B	B1	B2
280	140	140	19	14	413	87	325

D	D1	D2	D3	D4	H	H1	H2
165	125	110	99	53	230	220	273

EVOPLUS SAN - WET ROTOR ELECTRONIC CIRCULATORS

Pumped liquid temperature range: from -10 °C to +110 °C - Maximum operating pressure: 16 bar (1600 kPa)

EVOPLUS B 40/340.65 SAN M

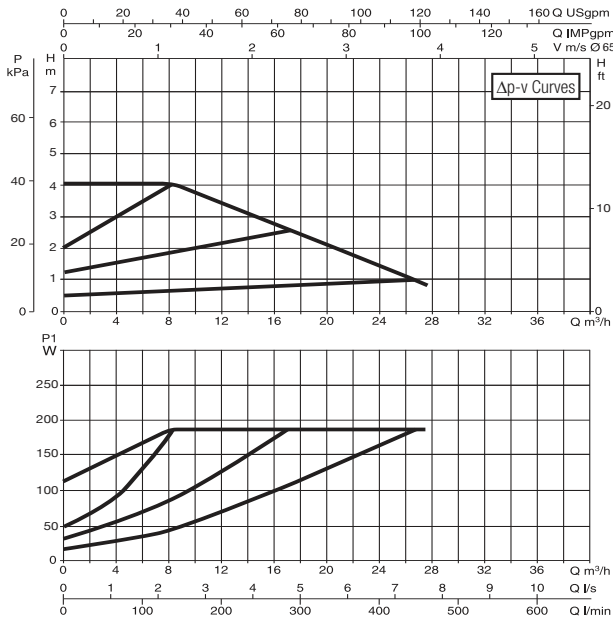

EVOPLUS B 60/340.65 SAN M

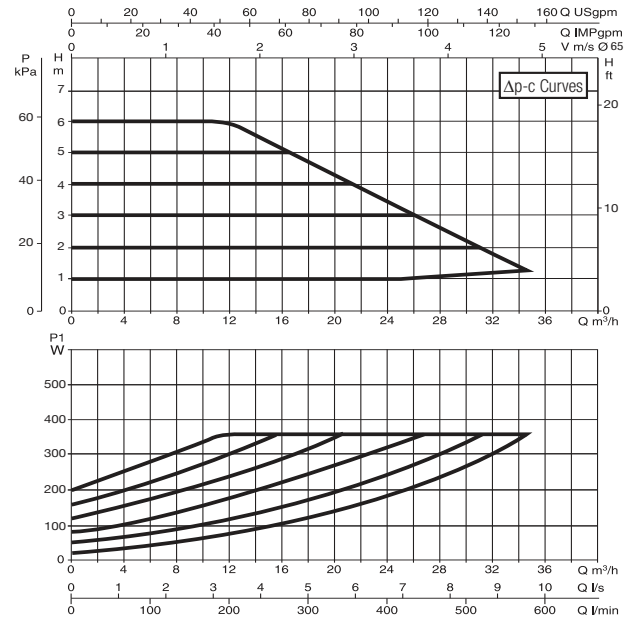
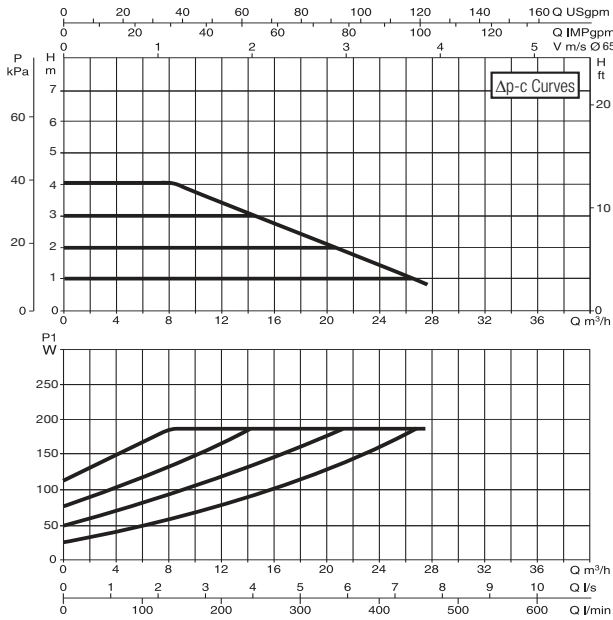
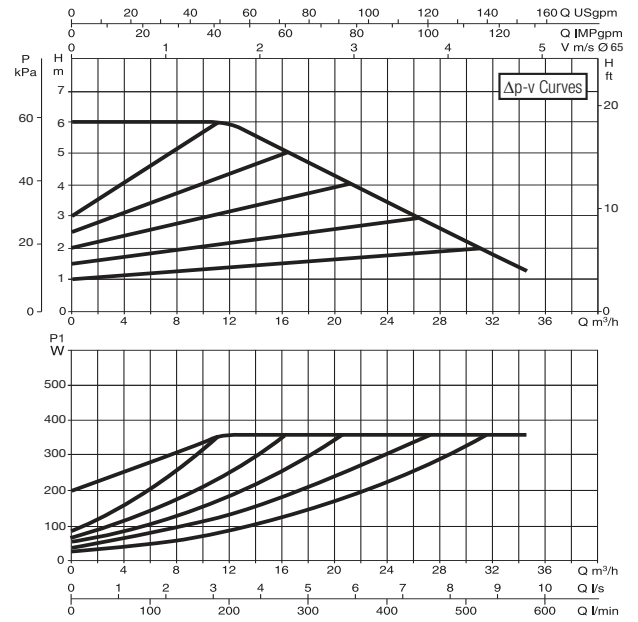

The curves are based on kinematic viscosity values = 1 mm²/s and density equal to 1000 kg/m³. Curve tolerance according to ISO 9906. Fixed speed curves available on the DNA.

MODEL	CENTRE DISTANCE mm	COUNTERFLANGES ON REQUEST	POWER INPUT 50/60 Hz	P1 MAX W	In A	MINIMUM SUCTION PRESSURE			WEIGHT Kg
						t°	90°	100°	
EVOPLUS B 40/340.65 SAN M	340	DN 65 PN 10	220/240 V	190	1,1	m.c.w.	20	25	27
EVOPLUS B 60/340.65 SAN M	340	DN 65 PN 10	220/240 V	355	1,8	m.c.w.	20	25	27,2

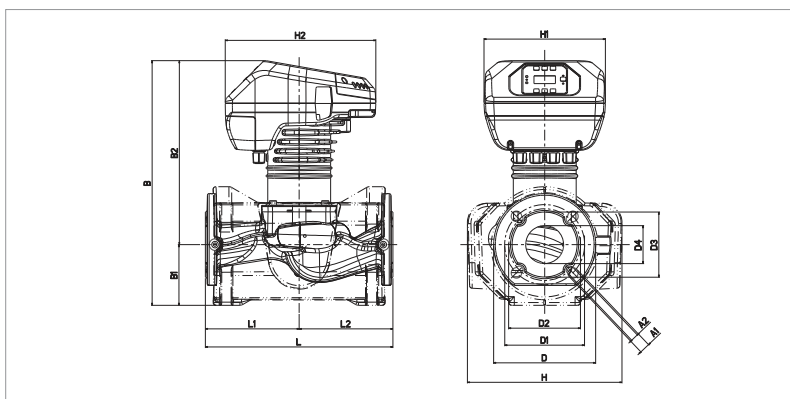

L	L1	L2	A1	A2	B	B1	B2
340	170	170	19	14	443	110	333

D	D1	D2	D3	D4	H	H1	H2
185	145	130	118	69	280	220	273

EVOPLUS SAN - WET ROTOR ELECTRONIC CIRCULATORS

Pumped liquid temperature range: from -10 °C to +110 °C - Maximum operating pressure: 16 bar (1600 kPa)

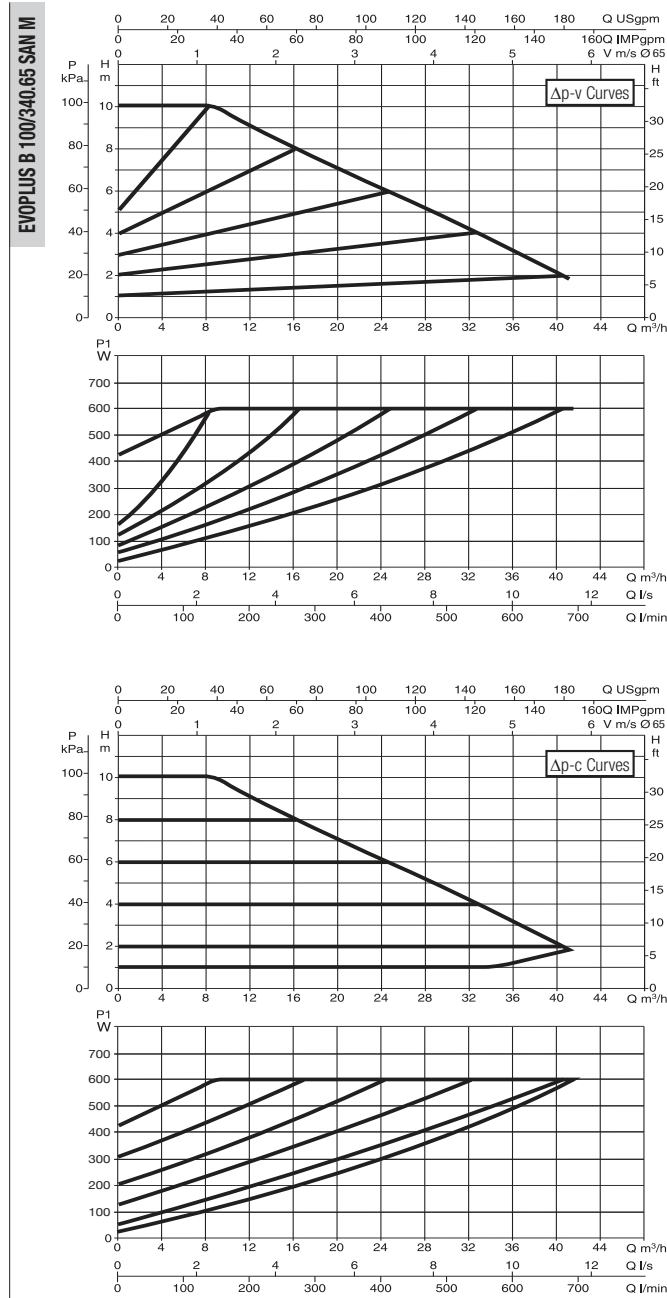
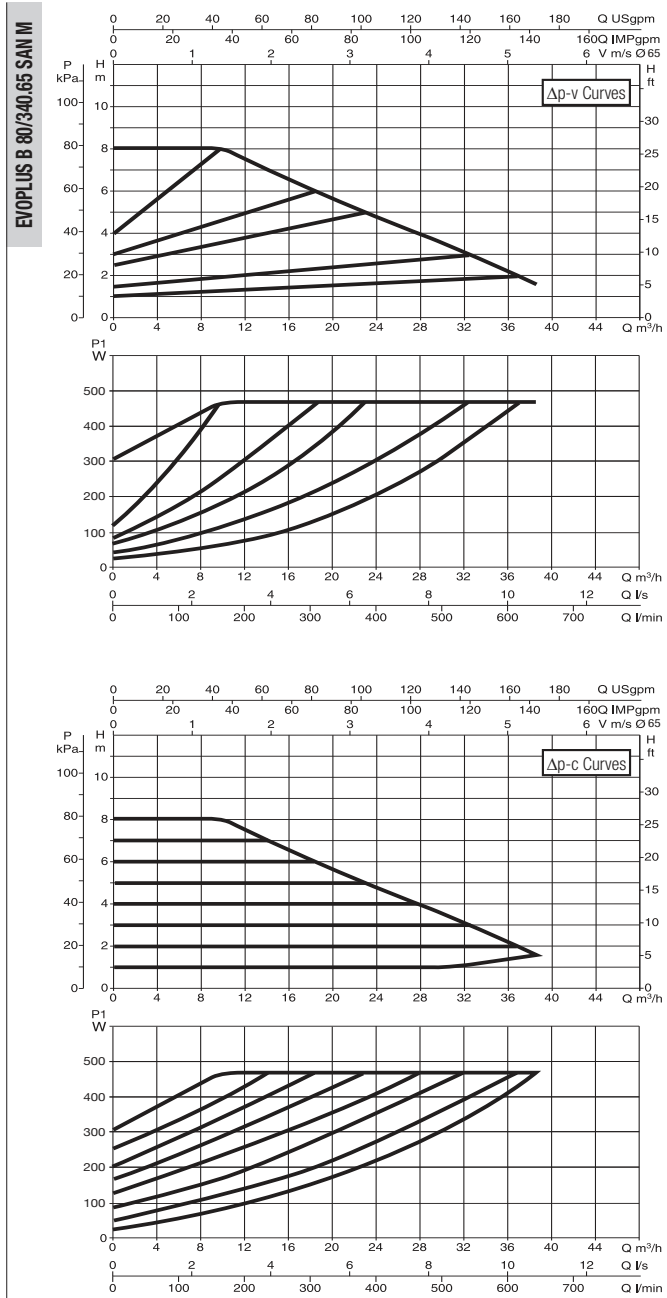

The curves are based on kinematic viscosity values = 1 mm²/s and density equal to 1000 kg/m³. Curve tolerance according to ISO 9906. Fixed speed curves available on the DNA.

MODEL	CENTRE DISTANCE mm	COUNTERFLANGES ON REQUEST	POWER INPUT 50/60 Hz	P1 MAX W	In A	MINIMUM SUCTION PRESSURE			WEIGHT Kg
						t°	90°	100°	
EVOPLUS B 80/340.65 SAN M	340	DN 65 PN 10	220/240 V	465	2,2	m.c.w.	20	25	27,8
EVOPLUS B 100/340.65 SAN M	340	DN 65 PN 10	220/240 V	590	2,8	m.c.w.	20	25	28

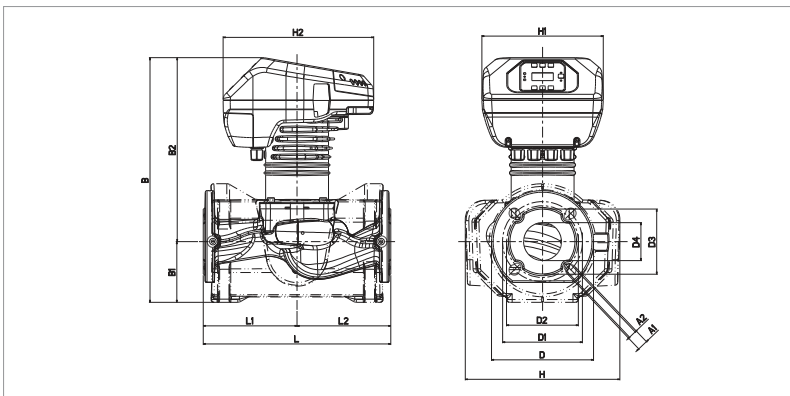

L	L1	L2	A1	A2	B	B1	B2
340	170	170	19	14	443	110	333

D	D1	D2	D3	D4	H	H1	H2
185	145	130	118	69	280	220	273

EVOPLUS SAN - WET ROTOR ELECTRONIC CIRCULATORS

Pumped liquid temperature range: from -10 °C to +110 °C - Maximum operating pressure: 16 bar (1600 kPa)

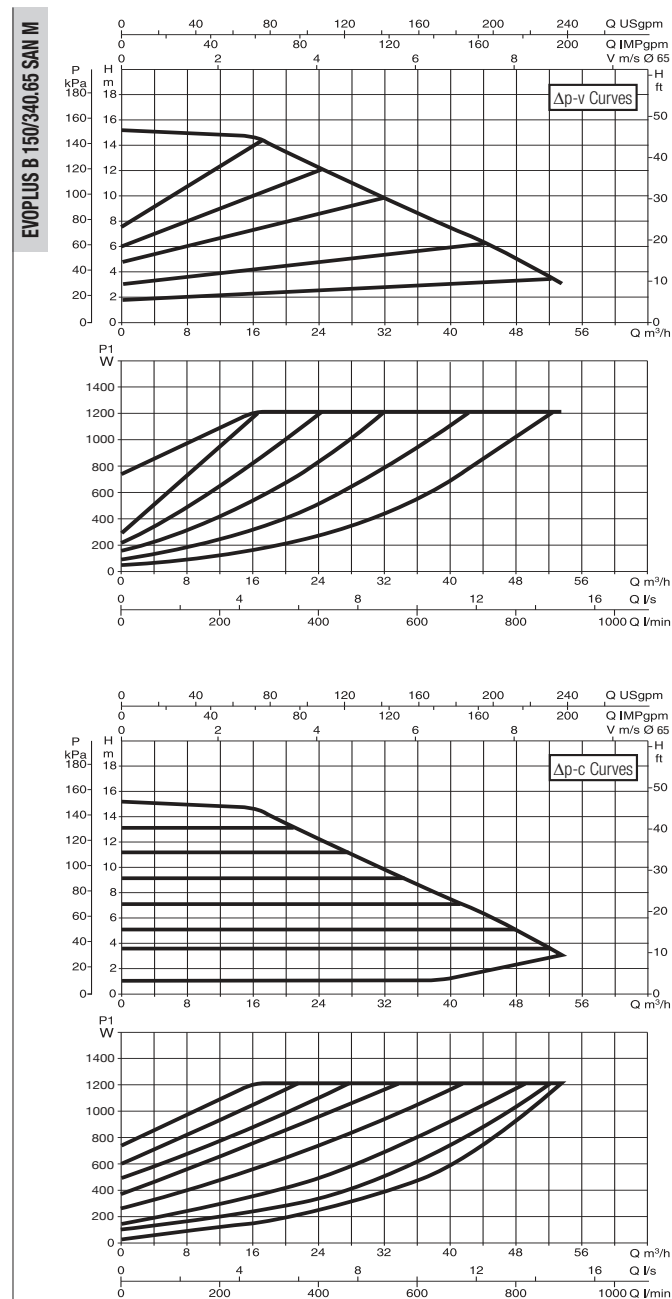
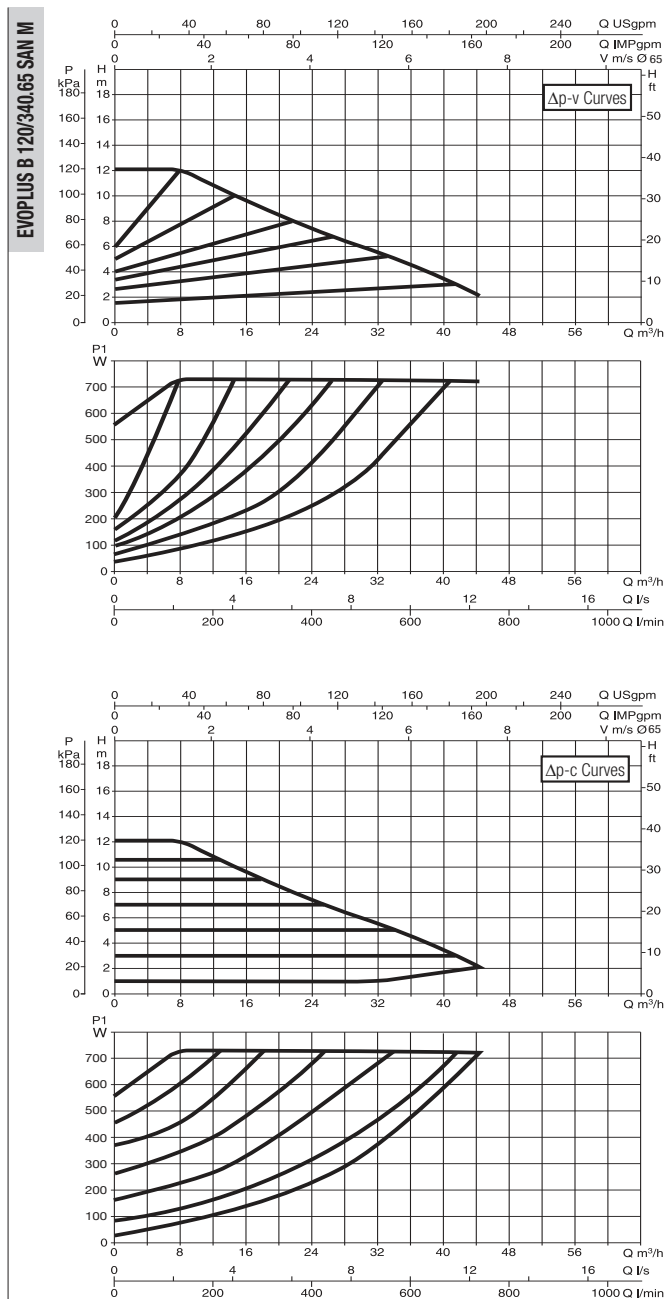

The curves are based on kinematic viscosity values = 1 mm²/s and density equal to 1000 kg/m³. Curve tolerance according to ISO 9906. Fixed speed curves available on the DNA.

MODEL	INTERASSE mm	COUNTERFLANGES ON REQUEST	POWER INPUT 50/60 Hz	P1 MAX W	In A	MINIMUM SUCTION PRESSURE			WEIGHT Kg
						t°	90°	100°	
EVOPLUS B 120/340.65 SAN M	340	DN 65 PN 10	220/240 V	730	3,45	m.c.w.	20	25	28,2
EVOPLUS B 150/340.65 SAN M	340	DN 65 PN 10	220/240 V	1210	5,5	m.c.w.	20	25	30

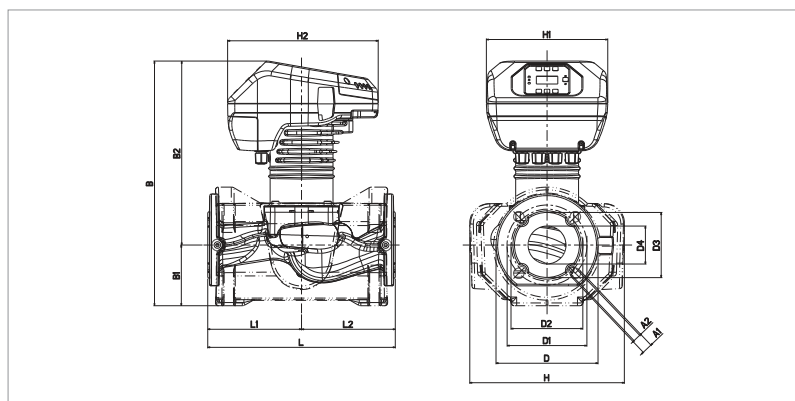

L	L1	L2	A1	A2	B	B1	B2
340	170	170	19	14	443	110	333

D	D1	D2	D3	D4	H	H1	H2
185	145	130	118	69	280	220	273

DAB

P U M P S S E L E C T O R



On-line selection tool

 **DAB PUMPS LTD.**
6 Gilbert Court
Newcomen Way
Severalls Business Park
Colchester
Essex
CO4 9WN - UK
salesuk@dwtgroup.com
Tel. +44 0333 777 5010

 **DAB PUMPS IBERICA S.L.**
Calle Verano 18-20-22
28850 - Torrejón de Ardoz - Madrid
Spain
Info.spain@dwtgroup.com
Tel. +34 91 6569545
Fax: + 34 91 6569676

 **DAB PUMPS SOUTH AFRICA (PTY) LTD**
Twenty One industrial Estate,
16 Purlin Street, Unit B, Warehouse 4
Olifantsfontein -1666 - South Africa
info.sa@dwtgroup.com
Tel. +27 12 361 3997

 **DAB PUMPS (QINGDAO) CO. LTD.**
No.40 Kaituo Road, Qingdao Economic & Technological
Development Zone
Qingdao City, Shandong Province - China
PC: 266500
sales.cn@dwtgroup.com
Tel. +86 400 186 8280
Fax +86 53286812210

 **DAB PUMPS BV**
"tHofveld 6 C1
1702 Groot Bijgaarden - Belgium
info.belgium@dwtgroup.com
Tel. +32 2 4668353

 **DAB PUMPS HUNGARY KFT.**
H-8800
Nagykanizsa, Buda Ernő u.5
Hungary
Tel. +36 93501700

 **DAB PUMPS POLAND Sp. z o.o.**
Ul. Janka Muzykanta 60
02-188 Warszawa - Poland
polska@dabpumps.com.pl

 **DAB PUMPS DE MÉXICO, S.A. DE C.V.**
Av Amsterdam 101 Local 4
Col. Hipódromo Condesa,
Del. Cuauhtémoc CP 06170
Ciudad de México
Tel. +52 55 6719 0493

 **DAB PUMPS B.V.**
Albert Einsteinweg, 4
5151 DL Drunen - Nederland
info.netherlands@dwtgroup.com
Tel. +31 416 387280
Fax +31 416 387299

 **OOO DAB PUMPS**
Novgorodskaya str. 1, block G
office 308, 127247, Moscow - Russia
info.russia@dwtgroup.com
Tel. +7 495 122 0035
Fax +7 495 122 0036

 **DAB PUMPS OCEANIA PTY LTD**
426 South Gippsland Hwy,
Dandenong South VIC 3175 - Australia
info.oceania@dwtgroup.com
Tel. +61 1300 373 677

 **DAB PUMPS GMBH**
Am Nordpark 3
D - 41069 Mönchengladbach - Germany
info.germany@dwtgroup.com
Tel. +49 2161 47388-0
Fax +49 2161 47388-36

 **DAB PUMPS INC.**
3226 Benchmark Drive
Ladson, SC 29456 - USA
info.usa@dwtgroup.com
Tel. 1- 843-797-5002
Fax 1-843-797-3366

 **PT DAB PUMPS INDONESIA**
Satrio Tower lantai 26
unit C-D, Jl. Prof. Dr. Satrio Kav. C4,
Kel. Kuningan Timur, Kec. Setiabudi, Kota Adm.
Jakarta Selatan, Prov. DKI Jakarta. - Indonesia
Tel. +62 2129222850