

CENTRIFUGAL ELECTRONIC PUMPS

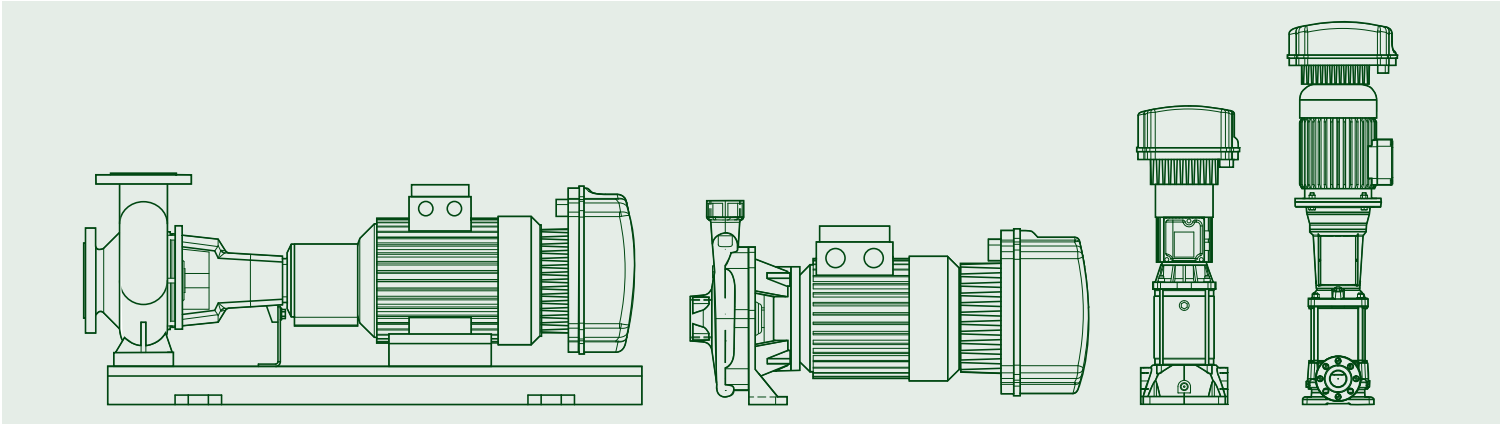

**TECHNICAL
CATALOGUE**



THE INTERNATIONAL CERTIFICATION NETWORK

CERTIFICATE

**IQNet and its partner
CISQ/IMG-CSQ**
hereby certify that the organization

DWT HOLDING SPA
VIA MARCO POLO 14 - 35035 MESTRINO (PD)
BRENDOLA (VI) - CASTELLO DI GODEGO (TV) - BIENTINA (PI) -
SAN GERMANO DEI BERICI (VI) - PRC CHINA - HUNGARY

for the following field of activities
*Design, production, sale and assistance of components and electronic controls for pumps, electropumps,
and pump sets for cold and hot water for civil, industrial and agricultural use*
Refer to quality manual for details of applications to ISO 9001:2008 requirements

has implemented and maintains a
Quality Management System
which fulfills the requirements of the following standard
ISO 9001:2008
Issued on: 2015 - 05 - 28 Expiry date: 2018 - 05 - 27

Registration Number: **IT - 824**

The status of validity of the certificate can be verified at <http://www.cisq.com> or by e-mail to fedisqa@cisq.com



Michael Drechsel
President of IQNET



Ing. Claudio Provetti
President of CISQ

IQNet Partners*:
AENOR Spain AFNOR Certification France AIB-Vincotte International Belgium ANCE-SIGE Mexico APCER Portugal CCC Cyprus
CISQ Italy CQC China CQM China CQS Czech Republic Cro Cert Croatia DQS Holding GmbH Germany
FCAV Brazil FONDONORMA Venezuela ICONTEC Colombia IMNC Mexico Inspecta Certification Finland IRAM Argentina
JQA Japan KIQ Korea MIRTEC Greece MSST Hungary Nemko AS Norway NSAI Ireland PCBC Poland
Quality Austria Austria RR Russia SII Israel SIQ Slovenia SIRIM QAS International Malaysia
SQS Switzerland SRAC Romania TEST St Petersburg Russia TSE Turkey YUQS Serbia
IQNet is represented in the USA by: AFNOR Certification, CISQ, DQS Holding GmbH and NSAI Inc.
* The list of IQNet partners is valid at the time of issue of this certificate. Updated information is available under www.iqnet-certification.com



www.IMG.it

ALLEGATO CERTIFICATO n. 9101.COGE
ANNEX CERTIFICATE

(*) Unità Operative:
(*) Operative Units:

DAB PUMPS SPA
VIA BONANNO PISANO 1 - 56031 BIENTINA (PI)

DAB PUMPS SPA
VIA DEL LAVORO 3 - 36040 SAN GERMANO DEI BERICI (VI)

DAB PUMPS QINGDAO CO., LTD
40 KAITUO ROAD, QINGDAO DEVELOPMENT ZONE - SHANGDONG PROVINCE, PRC CHINA

DAB PUMPS HUNGARY KFT
BUDA ERNO H - 8800 NAGYKANISZA HUNGARY

DATE:	PRIMA CERTIFICAZIONE FIRST CERTIFICATION	EMISSIONE CORRENTE CURRENT ISSUE	SCADENZA EXPIRY
	1995-07-17	2015-05-28	2018-05-27



IMG S.p.A. - VIA QUINTILIANO, 43 - 20138 MILANO

IAF: 18, 19, 29

ACCREDIA FEDERAZIONE CISQ

La validità del certificato è subordinata a sorveglianza annuale e esame completo del Sistema di Gestione con periodicità biennale.
The validity of the certificate is subjected to annual audit and a reassessment of the entire Management System within three years



www.IMG.it

CERTIFICATO N. 9101.COGE
CERTIFICATE N. 9101.COGE

SI CERTIFICA CHE IL SISTEMA QUALITÀ DI
WE HEREBY CERTIFY THAT THE QUALITY SYSTEM OPERATED BY

DWT HOLDING SPA
VIA MARCO POLO 14 - 35035 MESTRINO (PD)

UNITÀ OPERATIVE
OPERATIVE UNITS:
DAB PUMPS SPA
VIA MARCO POLO 14 - 35035 MESTRINO (PD)
DAB PUMPS SPA
VIA EINAUDI 2 - 36040 BRENDOLA (VI)
DAB PUMPS SPA
VIA E. FERMI 6-8-10 - 31030 CASTELLO DI GODEGO (TV)

Vedere gli Allegati per le altre Unità Operative (n° 1 pagina)
View the Annexes for the other Operative Units (n° 1 page)

E' CONFORME ALLA NORMA
IS IN COMPLIANCE WITH THE STANDARD
ISO 9001:2008

PER LE SEGUENTI ATTIVITÀ
FOR THE FOLLOWING ACTIVITIES

Progettazione, produzione, commercializzazione e assistenza di componenti e controlli elettronici per pompe, elettropompe e gruppi di pompaggio per acqua fredda e calda ad uso civile, industriale ed agricolo
Design, production, sale and assistance of components and electronic controls for pumps, electropumps, and pump sets for cold and hot water for civil, industrial and agricultural use

Riferirsi al manuale della qualità per l'applicabilità dei requisiti della norma ISO 9001:2008
Refer to quality manual for details of applications to ISO 9001:2008 requirements

IL PRESENTE CERTIFICATO È SOGGETTO AL RISPETTO DEL
REGOLAMENTO PER LA CERTIFICAZIONE DEI SISTEMI DI GESTIONE
THE USE AND THE VALIDITY OF THE CERTIFICATE SHALL SATISFY THE
REQUIREMENTS OF THE RULES FOR CERTIFICATION OF MANAGEMENT SYSTEMS

DATE:	PRIMA CERTIFICAZIONE FIRST CERTIFICATION	EMISSIONE CORRENTE CURRENT ISSUE	SCADENZA EXPIRY
	1995-07-17	2015-05-28	2018-05-27



IMG S.p.A. - VIA QUINTILIANO, 43 - 20138 MILANO







IAF: 18, 19, 29

ACCREDIA FEDERAZIONE CISQ

La validità del certificato è subordinata a sorveglianza annuale e esame completo del Sistema di Gestione con periodicità biennale.
The validity of the certificate is subjected to annual audit and a reassessment of the entire Management System within three years

CONTENTS

CENTRIFUGAL ELECTRONIC PUMPS

	KE SINGLE-IMPELLER		KVCE 30 - 50 - 80 - 120
	PAGE 3		PAGE 206
	KE DOUBLE-IMPELLER		KVE 3 - 6 - 10
	PAGE 16		PAGE 214
	NKM-GE / NKP-GE		NKVE 10 - 15 - 20 - 32 - 45 - 65 - 95
	PAGE 29		PAGE 220
	KDNE		
	PAGE 110		

HYDRAULIC EFFICIENCY

PAGE 241

ACCESSORIES



PAGE 249

TECHNICAL APPENDIX

PAGE 253

KE SINGLE-IMPELLER

SINGLE-IMPELLER CENTRIFUGAL ELECTRIC PUMPS WITH MCE/P INVERTER



TECHNICAL DATA

Operating range:

from 6 to 100 m³/h with head up to 60 metres.

Liquid temperature range:

from -10 °C to +50 °C for KE 36/200 and KE 40/200,
from -15 °C to +80 °C for the other pumps.

Pumped liquid: clean, free of solids and abrasives, non-viscous, non-aggressive, non-crystallised and chemically neutral, with properties similar to water.

Maximum ambient temperature: +40 °C.

Maximum operating pressure:

KE 36/200, KE 40/200, KE 55/200: 8 bar (800 kPa)
KE 40/400, KE 50/400, KE 30/800, KE 40/800, KE 50/800, KE 20/1200,
KE 25/1200, KE 35/1200: 10 bar (1000 kPa)

Protection class at the terminal board: IP 55.

Protection class: IP 44

Insulation class: F.

Installation: normally in horizontal or vertical position, provided that the motor is always above the pump.

APPLICATIONS

Single-impeller centrifugal pump suitable for domestic, civil, industrial and agricultural systems, and for decanting, mixing and irrigation uses.

CONSTRUCTION FEATURES OF THE PUMP

Pump body and motor support in cast iron.

Technopolymer or cast iron impeller, as per the TECHNICAL DATA table.

Carbon/ceramic mechanical seal.

CONSTRUCTION FEATURES OF THE MOTOR

Closed asynchronous type, external ventilation cooling.

Rotor running on ball bearings, oversized to ensure low noise and durability.

Construction according to CEI 2-3.

Controlled by MCE inverter.

Standard single-phase voltage: 1x230 V / 50-60 Hz

Special version on request: three-phase 3x400 V / 50 Hz, or three-phase 3x460 V / 60 Hz

Standard three-phase voltage: 3x400 V / 50 Hz

Special version on request: 3x460 V / 60 Hz

KE SINGLE-IMPELLER

SINGLE-IMPELLER CENTRIFUGAL ELECTRIC PUMPS WITH MCE/P INVERTER

MCE/P INVERTER



CONSTRUCTION FEATURES OF THE ELECTRONICS: MCE/P INVERTER

The inverter continuously adjusts the rotation speed of the electric pump, keeping the pressure constant, even when the flow rate varies.

The other electric pumps, also with variable speed, are activated in cascade after the first one has reached maximum speed. Through modulation, they compensate the pressure fluctuations of the system.

For every operating cycle, it is possible to switch the restart to a different pump, therefore ensuring even use of all electric pumps.

It is possible to set operation times for each individual pump, switching to another pump after such set times.

The "SP" pressure can be adjusted by the user using the "+" and "-" keys found on the MCE/P (as a rule, all the pumps are set to the same pressure value). With the new MCE/P, it is sufficient to set the data on one of the devices, and it will be automatically propagated to the other pumps of the system.

MODES OF OPERATION

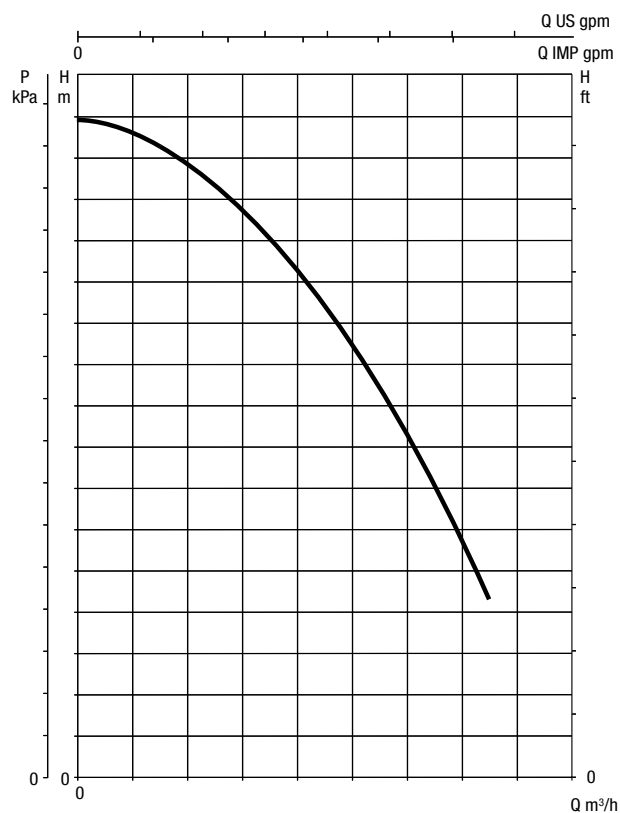

PERFORMANCE CURVES WITHOUT INVERTER

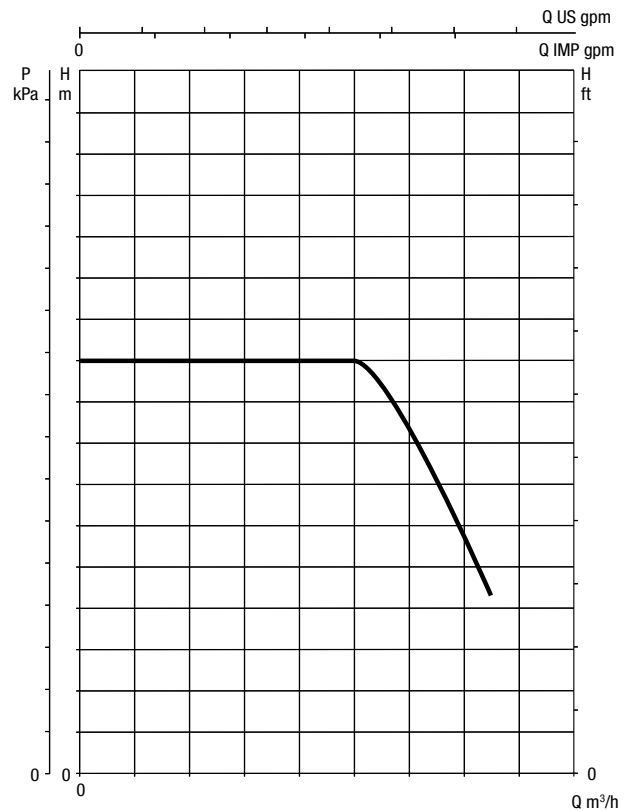

PERFORMANCE CURVES WITH INVERTER

The inverter is capable of maintaining a constant pressure even when the flow rate varies.

The operating pressure can be adjusted by the user.

A good pressure set-point is between 1/3 and 2/3 of the maximum head of the electric pump. In this way, high efficiency of the pump is maintained, together with maximum saving.

In addition, the MCE/P does not block the pump if the pressure is not reached, but the flow is present. This prevents service interruptions in case of high flows.

For more information refer to the technical appendix.

KE SINGLE-IMPELLER

SINGLE-IMPELLER CENTRIFUGAL ELECTRIC PUMPS WITH MCE/P INVERTER

MATERIALS

N.	PARTS	MATERIALS	MODELS
1	PUMP BODY	CAST IRON 200 UNI ISO 185	
3	SUPPORT	CAST IRON 200 UNI ISO 185	
4	IMPELLER	TECHNOPOLYMER A	K 36/200; K 40/200;
		TECHNOPOLYMER B	K 55/200
		CAST IRON 200 UNI ISO 185	K 40/400; K 50/400; K 30/800; K 40/800; K 50/800; K 25/1200; K 35/1200
7	SHAFT WITH ROTOR	STAINLESS STEEL AISI 303 X10CRNiS 1089 UNI 6900/71	K 36/200; K 40/200; K 55/200
		STAINLESS STEEL AISI 304 X5CRNi 1810 UNI 6900/71	K 40/400; K 50/400; K 30/800; K 40/800; K 50/800; K 25/1200; K 35/1200
16	MECHANICAL SEAL	CARBON / CERAMIC	
28	OR RING	NBR RUBBER	

* In contact with the liquid

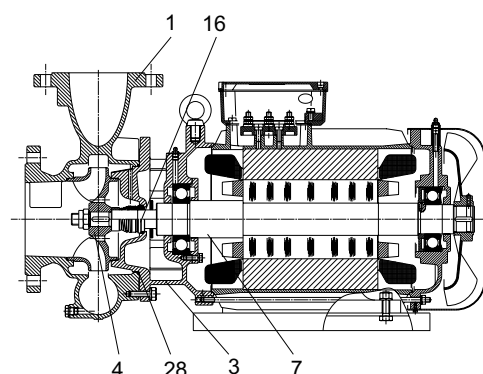

SELECTION TABLE - KE SINGLE-PROPELLER

MODEL	Q= m³/h Q= l/min	0	4,8	6	7,2	9	9,6	10,8	12	15	18	24	30	36	42	60	72	84	96
		0	80	100	120	150	160	180	200	250	300	400	500	600	700	1000	1200	1400	1600
KE 36/200 T MCE30/P	H (m)	36,6	36	35,5	35	34	33,3	32,5	31,5	28	23,5								
KE 40/200 T MCE30/P		41,3	41	40,5	40	39	38,8	38	37	33,5	29								
KE 55/200 T MCE55/P		54		54	53,9	53,2	53	52	51,5	48,5	45								
KE 40/400 T MCE55/P		50,5							49	48	45	37	24						
KE 50/400 T MCE110/P		62							61	60	59	54,5	46						
KE 30/800 T MCE110/P		44										42	40	38	35	21,5			
KE 40/800 T MCE110/P		51,5										50	48	47	43,5	32,5	21		
KE 50/800 T MCE110/P		58										56,5	55	53,5	51	41	31		
KE 25/1200 T MCE110/P		40,7										39	38,5	38	37	33,5	30	25	18
KE 35/1200 T MCE110/P		45												43	42,5	38,5	35	31,5	27

KE 36/200 - SINGLE-IMPELLER CENTRIFUGAL ELECTRIC PUMPS WITH MCE/P INVERTER, FOR WATER SUPPLY IN DOMESTIC, CIVIL, AND INDUSTRIAL ENVIRONMENTS

Pumped liquid temperature range: from -10 °C to +50 °C - Maximum ambient temperature: +40 °C

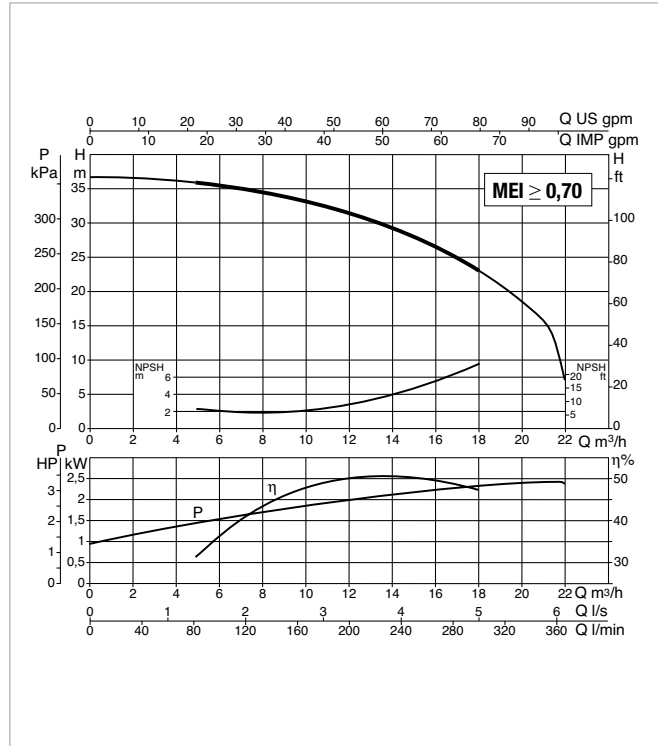
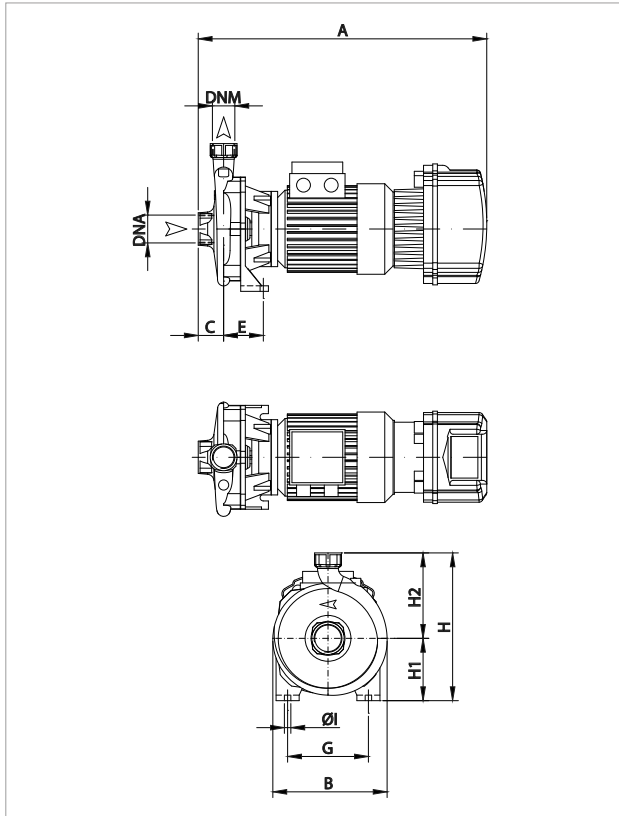

See hydraulic efficiency details on page 241.

The performance curves are based on kinematic viscosity values = 1 mm²/s and density equal to 1000 kg/m³. Curve tolerance according to ISO 9906.

MODEL	ELECTRICAL DATA					
	POWER INPUT 50 Hz	P1 MAX kW	P2 NOMINAL		In A	r.p.m.
			kW	HP		
KE 36/200 T MCE30/P	3 x 400 V	3,2	2,2	3	6,96	2895

MODEL	A	B	C	E	G	I	H	H1	H2	DNA			DNM			PACKING DIMENSIONS			VOLUME (m ³)	WEIGHT kg	
										X1	Y1	Z1	X2	Y2	Z2	L/A	L/B	H			
KE 36/200 T MCE30/P	625	267	55	86	175	14	357	135	185	G 2"	-	-	G 1 1/4	-	-	-	826	430	426	0,151	39,9

KE 40/200 - SINGLE-IMPELLER CENTRIFUGAL ELECTRIC PUMPS WITH MCE/P INVERTER, FOR WATER SUPPLY IN DOMESTIC, CIVIL, AND INDUSTRIAL ENVIRONMENTS

Pumped liquid temperature range: from -10 °C to +50 °C - Maximum ambient temperature: +40 °C

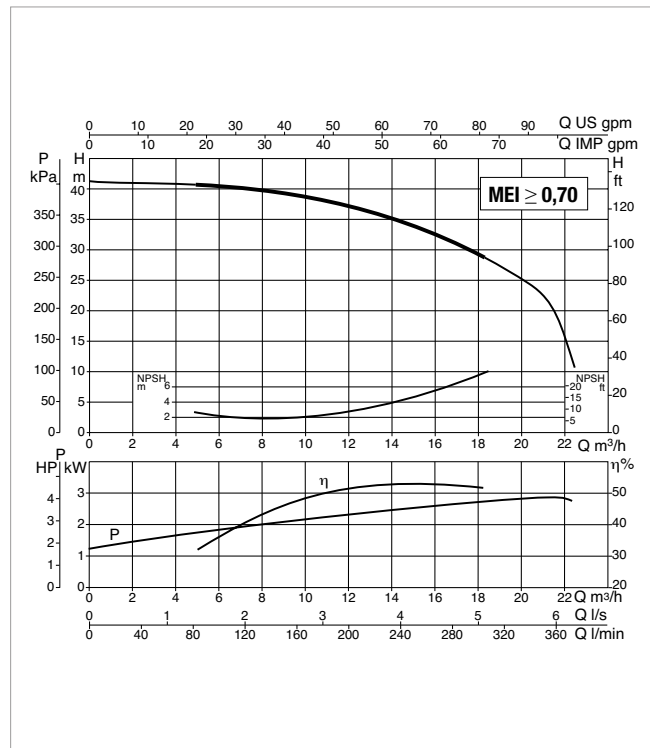
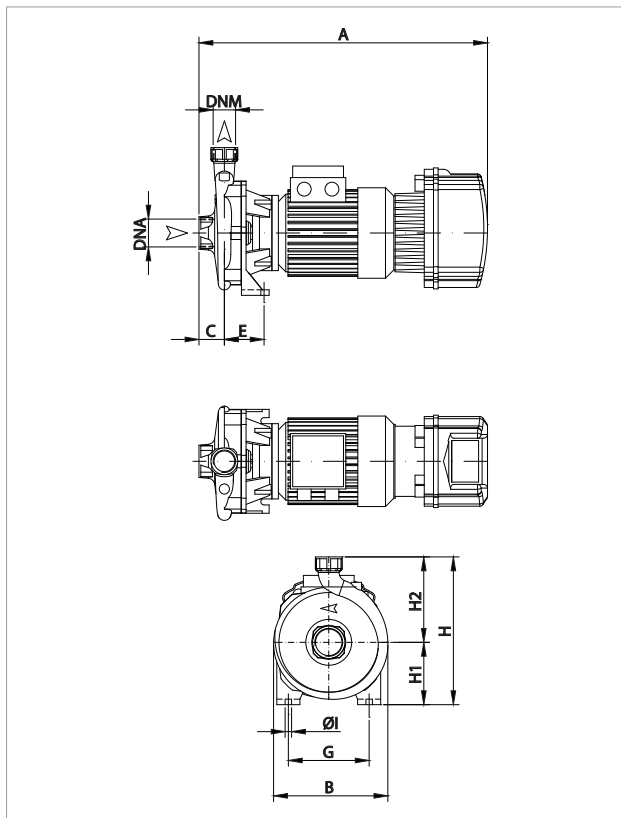

See hydraulic efficiency details on page 241.

The performance curves are based on kinematic viscosity values = 1 mm²/s and density equal to 1000 kg/m³. Curve tolerance according to ISO 9906.

MODEL	ELECTRICAL DATA					
	POWER INPUT 50 Hz	P1 MAX kW	P2 NOMINAL		In A	r.p.m.
			kW	HP		
KE 40/200 T MCE30/P	3 x 400 V	3,8	3	4	8,93	2924

MODEL	A	B	C	E	G	I	H	H1	H2	DNA			DNM			PACKING DIMENSIONS			VOLUME (m ³)	WEIGHT kg	
										X1	Y1	Z1	X2	Y2	Z2	L/A	L/B	H			
KE 40/200 T MCE30/P	625	267	55	86	175	14	357	135	185	G 2"	-	-	G 1 1/4"	-	-	-	826	430	426	0,151	41,7

KE 55/200 - SINGLE-IMPELLER CENTRIFUGAL ELECTRIC PUMPS WITH MCE/P INVERTER, FOR WATER SUPPLY IN DOMESTIC, CIVIL, AND INDUSTRIAL ENVIRONMENTS

Pumped liquid temperature range: from -15 °C to +80 °C - Maximum ambient temperature: +40 °C

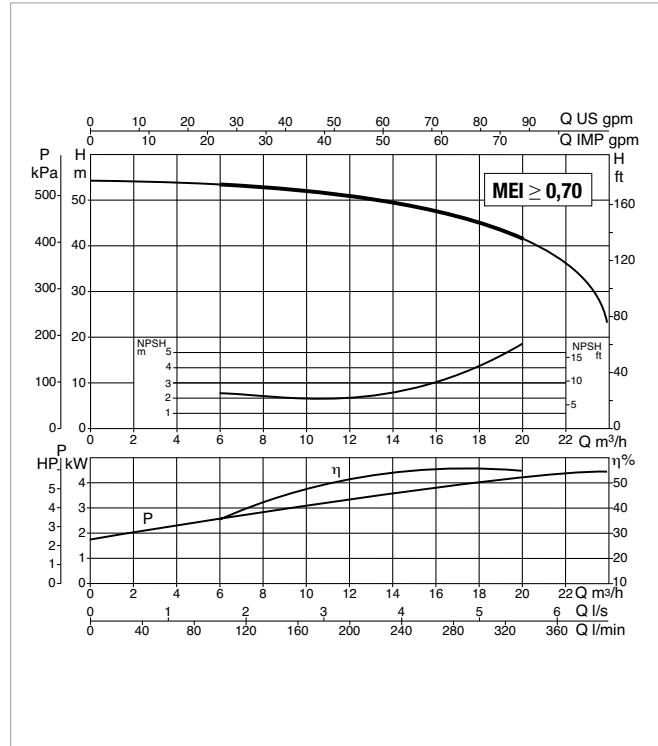
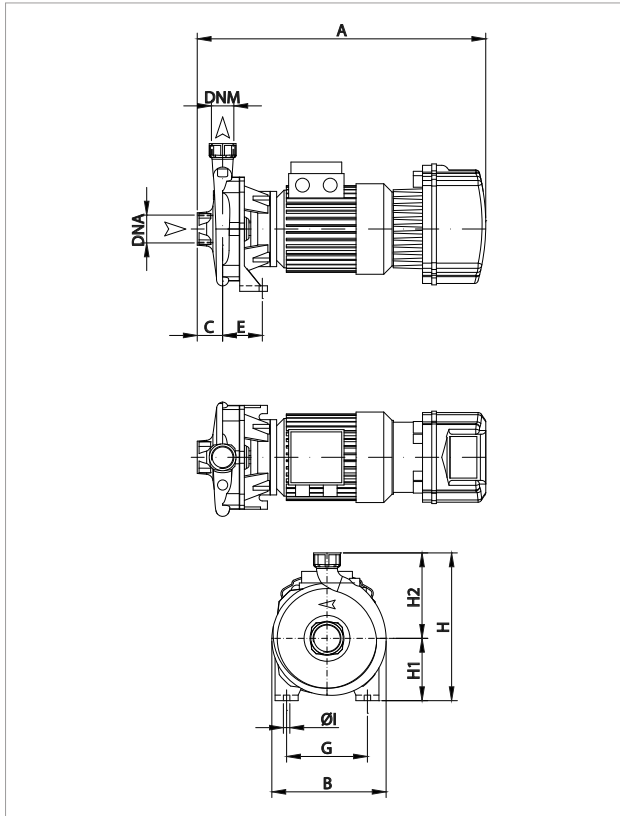

See hydraulic efficiency details on page 241.

The performance curves are based on kinematic viscosity values = 1 mm²/s and density equal to 1000 kg/m³. Curve tolerance according to ISO 9906.

MODEL	ELECTRICAL DATA					
	POWER INPUT 50 Hz	P1 MAX kW	P2 NOMINAL		In A	r.p.m.
			kW	HP		
KE 55/200 T MCE55/P	3 x 400V	5,3	4	5,5	10,90	2871

MODEL	A	B	C	E	G	I	H	H1	H2	DNA			DNM			PACKING DIMENSIONS			VOLUME (m ³)	WEIGHT kg	
										X1	Y1	Z1	X2	Y2	Z2	L/A	L/B	H			
KE 55/200 T MCE55/P	625	267	55	86	175	14	357	135	185	G 2"	-	-	G 1 1/4	-	-	-	826	430	426	0,151	41,7

KE 40/400 - SINGLE-IMPELLER CENTRIFUGAL ELECTRIC PUMPS WITH MCE/P INVERTER, FOR WATER SUPPLY IN DOMESTIC, CIVIL, AND INDUSTRIAL ENVIRONMENTS

Pumped liquid temperature range: from -15 °C to +80 °C - Maximum ambient temperature: +40 °C

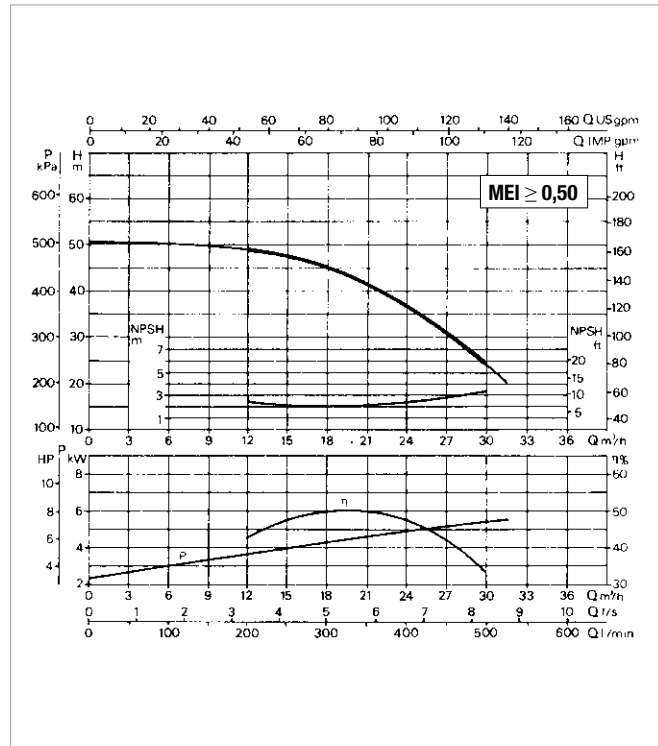
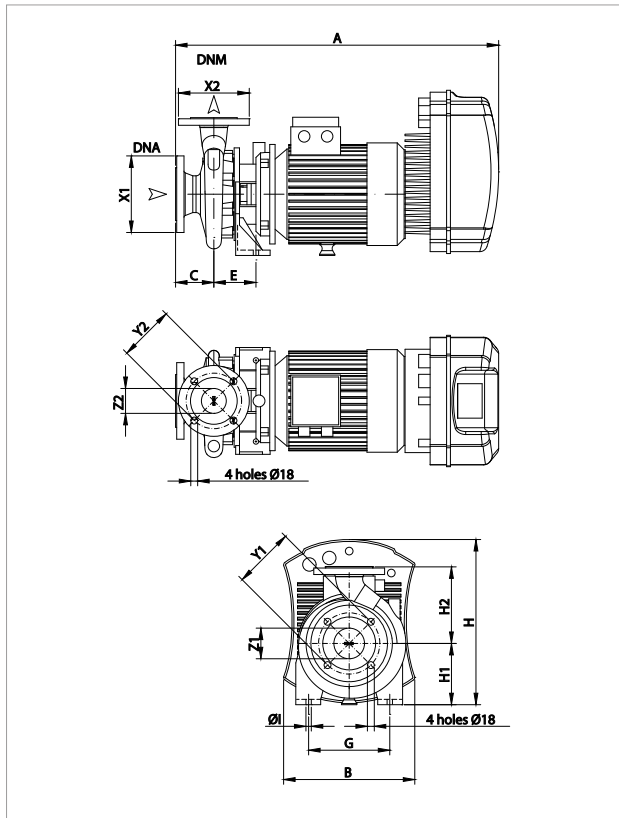

See hydraulic efficiency details on page 241.

The performance curves are based on kinematic viscosity values = 1 mm²/s and density equal to 1000 kg/m³. Curve tolerance according to ISO 9906.

MODEL	ELECTRICAL DATA					
	POWER INPUT 50 Hz	P1 MAX kW	P2 NOMINAL		In A	r.p.m.
			kW	HP		
KE 40/400 T MCE55/P	3 x 400 V	6,7	5,5	7,5	14,67	2938

MODEL	A	B	C	E	G	I	H	H1	H2	DNA			DNM			PACKING DIMENSIONS			VOLUME (m ³)	WEIGHT kg		
										X1	Y1	Z1	X2	Y2	Z2	L/A	L/B	H				
KE 40/400 T MCE55/P	768	273	100	110	212	14	360	160	200	-	185	145	65	-	165	125	50	826	430	426	0,151	86,6

KE 50/400 - SINGLE-IMPELLER CENTRIFUGAL ELECTRIC PUMPS WITH MCE/P INVERTER, FOR WATER SUPPLY IN DOMESTIC, CIVIL, AND INDUSTRIAL ENVIRONMENTS

Pumped liquid temperature range: from -15 °C to +80 °C - Maximum ambient temperature: +40 °C

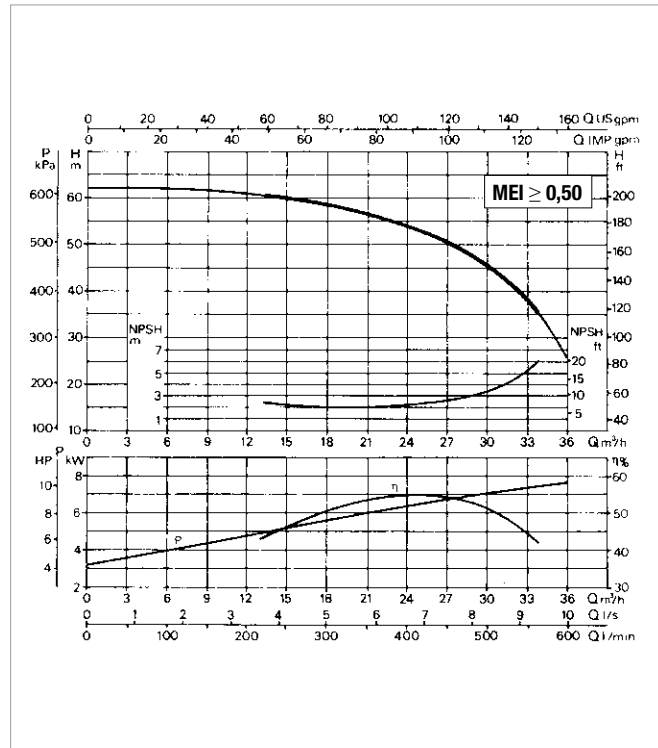
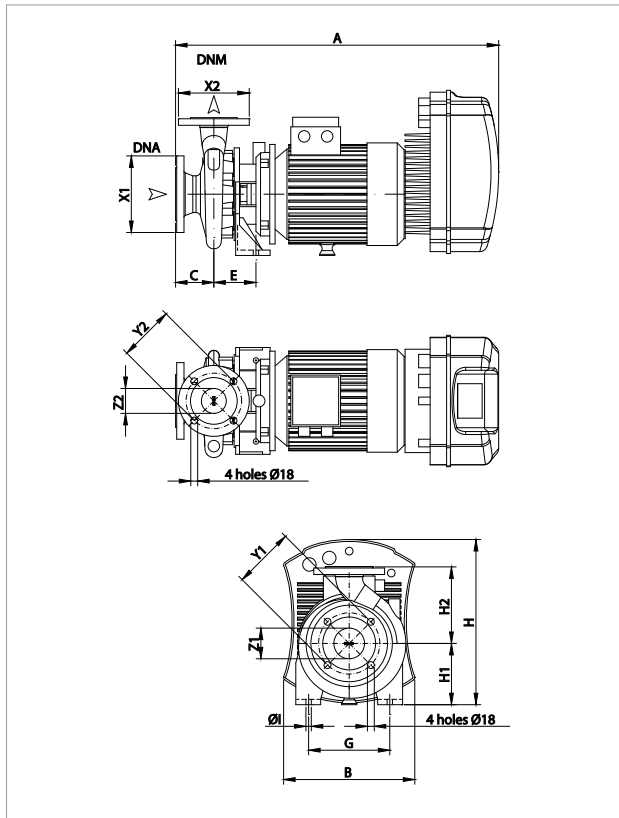

See hydraulic efficiency details on page 241.

The performance curves are based on kinematic viscosity values = 1 mm²/s and density equal to 1000 kg/m³. Curve tolerance according to ISO 9906.

MODEL	ELECTRICAL DATA					
	POWER INPUT 50 Hz	P1 MAX kW	P2 NOMINAL		In A	r.p.m.
			kW	HP		
KE 50/400 T MCE110/P	3 x 400V	8,9	7,5	10	18,74	2935

MODEL	DIMENSIONS									PACKING DIMENSIONS			VOLUME (m ³)	WEIGHT kg								
	A	B	C	E	G	I	H	H1	H2	L/A	L/B	H										
	X1	Y1	Z1	X2	Y2	Z2																
KE 50/400 T MCE110/P	818	341	100	110	212	14	428	160	200	-	185	145	65	-	165	125	50	1026	530	546	0,297	91,7

KE 30/800 - SINGLE-IMPELLER CENTRIFUGAL ELECTRIC PUMPS WITH MCE/P INVERTER, FOR WATER SUPPLY IN DOMESTIC, CIVIL, AND INDUSTRIAL ENVIRONMENTS

Pumped liquid temperature range: from -15 °C to +80 °C - Maximum ambient temperature: +40 °C

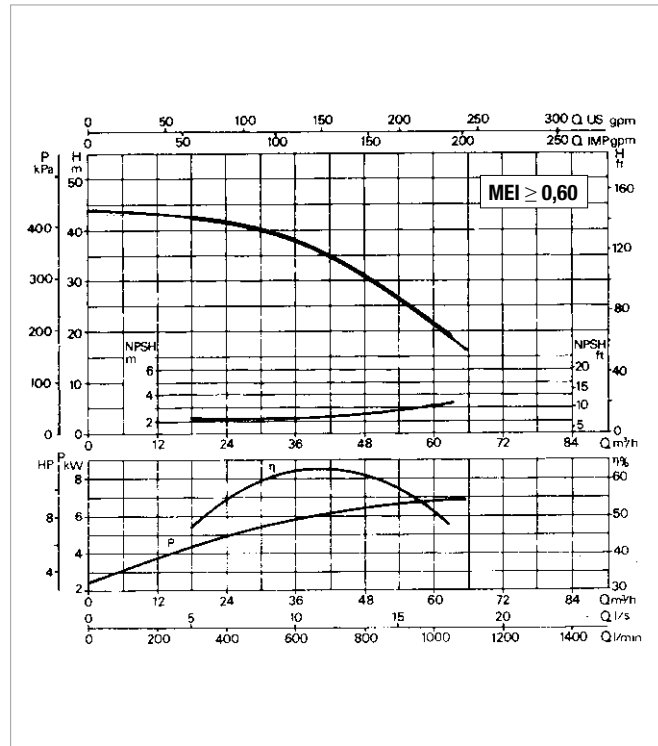
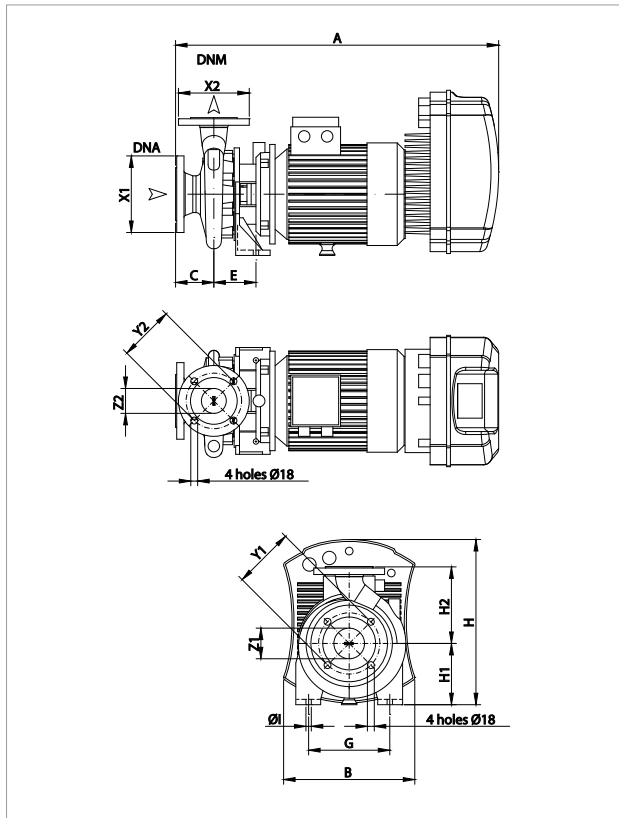

See hydraulic efficiency details on page 241.

The performance curves are based on kinematic viscosity values = 1 mm²/s and density equal to 1000 kg/m³. Curve tolerance according to ISO 9906.

MODEL	ELECTRICAL DATA					
	POWER INPUT 50 Hz	P1 MAX kW	P2 NOMINAL		In A	r.p.m.
			kW	HP		
KE 30/800 T MCE110/P	3 x 400V	8,5	7,5	10	18,19	2936

MODEL	A	B	C	E	G	I	H	H1	H2	DNA			DNM			PACKING DIMENSIONS			VOLUME (m ³)	WEIGHT kg		
										X1	Y1	Z1	X2	Y2	Z2	L/A	L/B	H				
KE 30/800 T MCE110/P	858	341	100	110	212	14	428	160	225	-	200	160	80	-	185	145	65	1026	530	546	0,297	103,1

KE 40/800 - SINGLE-IMPELLER CENTRIFUGAL ELECTRIC PUMPS WITH MCE/P INVERTER, FOR WATER SUPPLY IN DOMESTIC, CIVIL, AND INDUSTRIAL ENVIRONMENTS

Pumped liquid temperature range: from -15 °C to +80 °C - Maximum ambient temperature: +40 °C

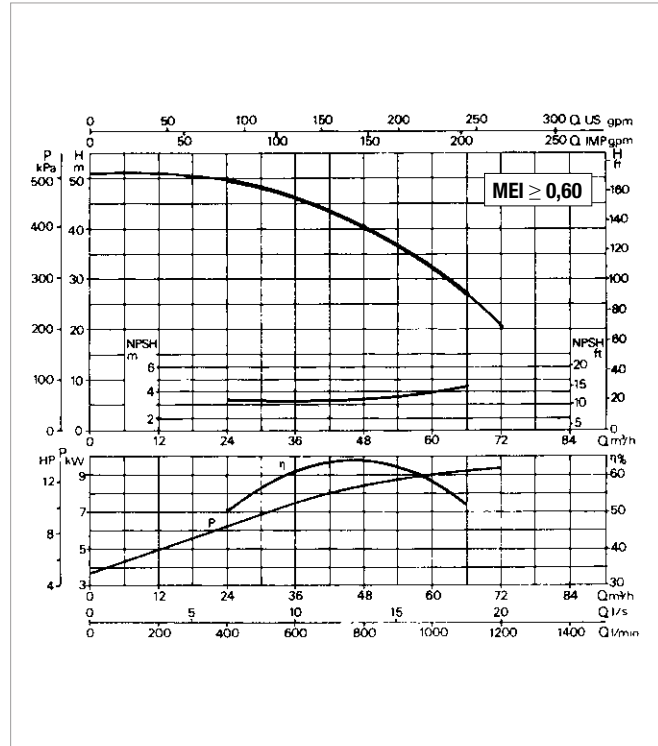
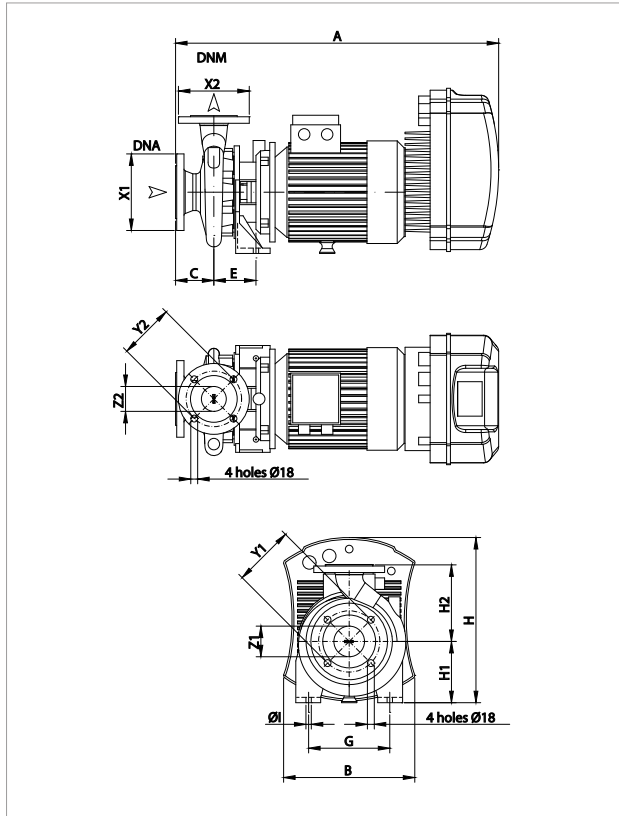

See hydraulic efficiency details on page 241.

The performance curves are based on kinematic viscosity values = 1 mm²/s and density equal to 1000 kg/m³. Curve tolerance according to ISO 9906.

MODEL	ELECTRICAL DATA					
	POWER INPUT 50 Hz	P1 MAX kW	P2 NOMINAL		In A	r.p.m.
			kW	HP		
KE 40/800 T MCE110/P	3 x 400 V	10,4	9,2	12,5	21,48	2941

MODEL	DIMENSIONS										PACKING DIMENSIONS			VOLUME (m³)	WEIGHT kg							
	A	B	C	E	G	I	H	H1	H2	DNA			DNM									
	X1	Y1	Z1	X2	Y2	Z2	L/A	L/B	H													
KE 40/800 T MCE110/P	858	341	100	110	212	14	428	160	225	-	200	160	80	-	185	145	65	1026	530	546	0,297	107,9

KE 50/800 - SINGLE-IMPELLER CENTRIFUGAL ELECTRIC PUMPS WITH MCE/P INVERTER, FOR WATER SUPPLY IN DOMESTIC, CIVIL, AND INDUSTRIAL ENVIRONMENTS

Pumped liquid temperature range: from -15 °C to +80 °C - Maximum ambient temperature: +40 °C

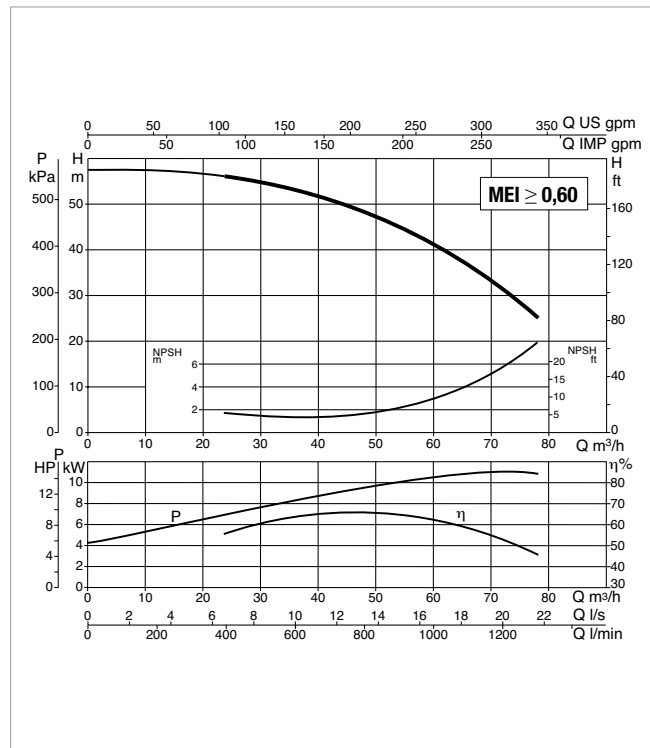
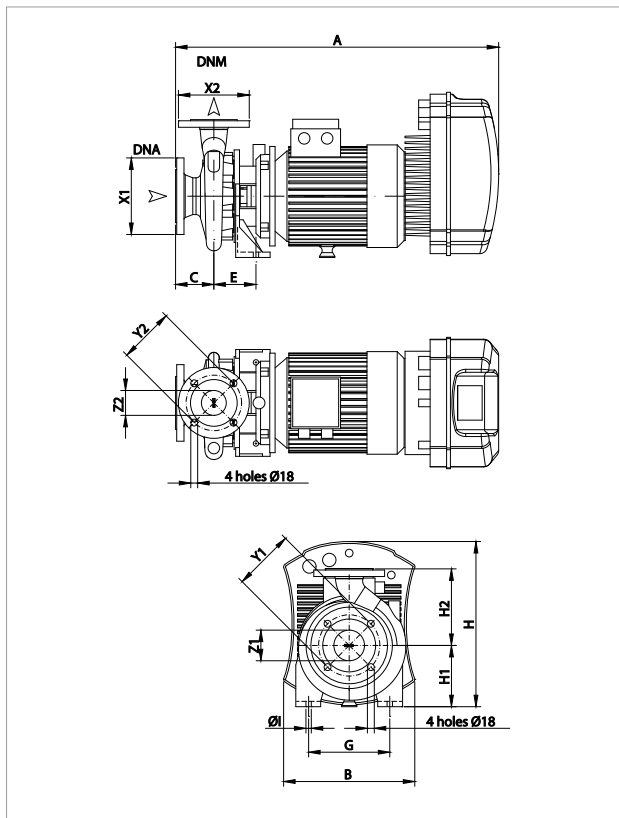

See hydraulic efficiency details on page 241.

The performance curves are based on kinematic viscosity values = 1 mm²/s and density equal to 1000 kg/m³. Curve tolerance according to ISO 9906.

MODEL	ELECTRICAL DATA					
	POWER INPUT 50 Hz	P1 MAX kW	P2 NOMINAL		In A	r.p.m.
			kW	HP		
KE 50/800 T MCE110/P	3 x 400V	13,5	11	15	27,49	2937

MODEL	DIMENSIONS										PACKING DIMENSIONS			VOLUME (m ³)	WEIGHT kg							
	A	B	C	E	G	I	H	H1	H2	DNA			DNM									
	X1	Y1	Z1	X2	Y2	Z2	L/A	L/B	H													
KE 50/800 T MCE110/P	858	341	100	110	212	14	428	160	225	-	200	160	80	-	185	145	65	1026	530	546	0,297	117,2

KE 25/1200 - SINGLE-IMPELLER CENTRIFUGAL ELECTRIC PUMPS WITH MCE/P INVERTER, FOR WATER SUPPLY IN DOMESTIC, CIVIL, AND INDUSTRIAL ENVIRONMENTS

Pumped liquid temperature range: from -15 °C to +80 °C - Maximum ambient temperature: +40 °C

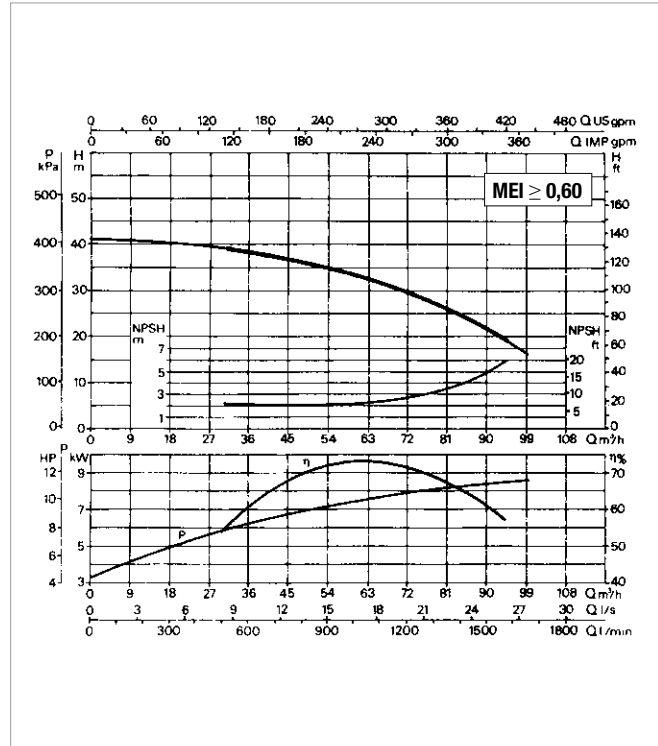
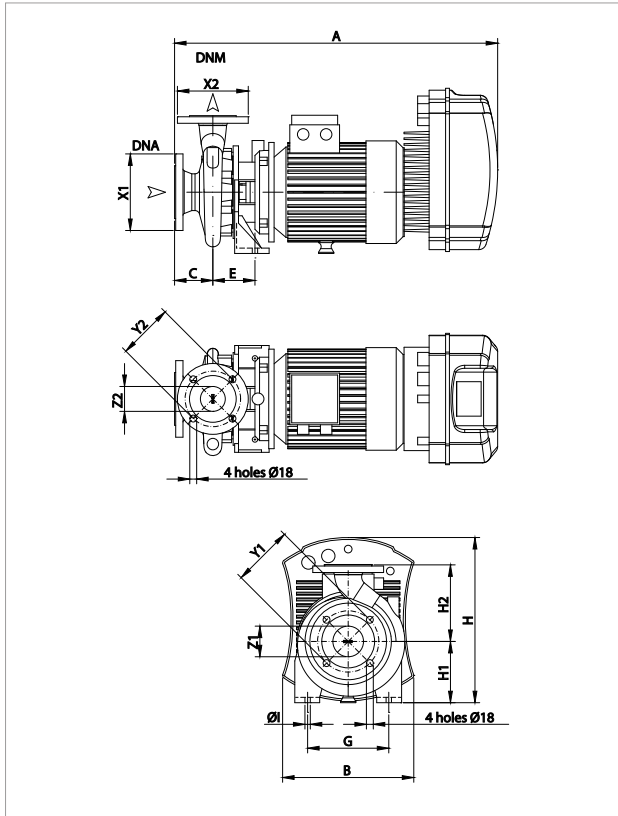

See hydraulic efficiency details on page 241.

The performance curves are based on kinematic viscosity values = 1 mm²/s and density equal to 1000 kg/m³. Curve tolerance according to ISO 9906.

MODEL	ELECTRICAL DATA					
	POWER INPUT 50 Hz	P1 MAX kW	P2 NOMINAL		In A	r.p.m.
			kW	HP		
KE 25/1200 T MCE110/P	3 x 400 V	12,0	10	12,5	20,92	2944

MODEL	DIMENSIONS										PACKING DIMENSIONS			VOLUME (m ³)	WEIGHT kg							
	A	B	C	E	G	I	H	H1	H2	DNA			DNM									
	X1	Y1	Z1	X2	Y2	Z2	L/A	L/B	H													
KE 25/1200 T MCE110/P	858	341	100	110	212	14	428	160	225	-	200	160	80	-	185	145	65	1026	530	546	0,297	106,9

KE 35/1200 - SINGLE-IMPELLER CENTRIFUGAL ELECTRIC PUMPS WITH MCE/P INVERTER, FOR WATER SUPPLY IN DOMESTIC, CIVIL, AND INDUSTRIAL ENVIRONMENTS

Pumped liquid temperature range: from -15 °C to +80 °C - Maximum ambient temperature: +40 °C

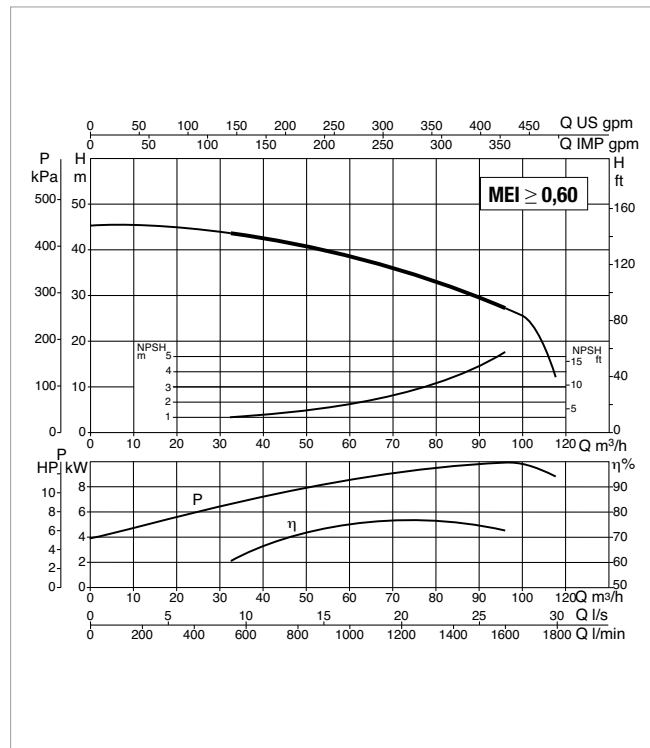
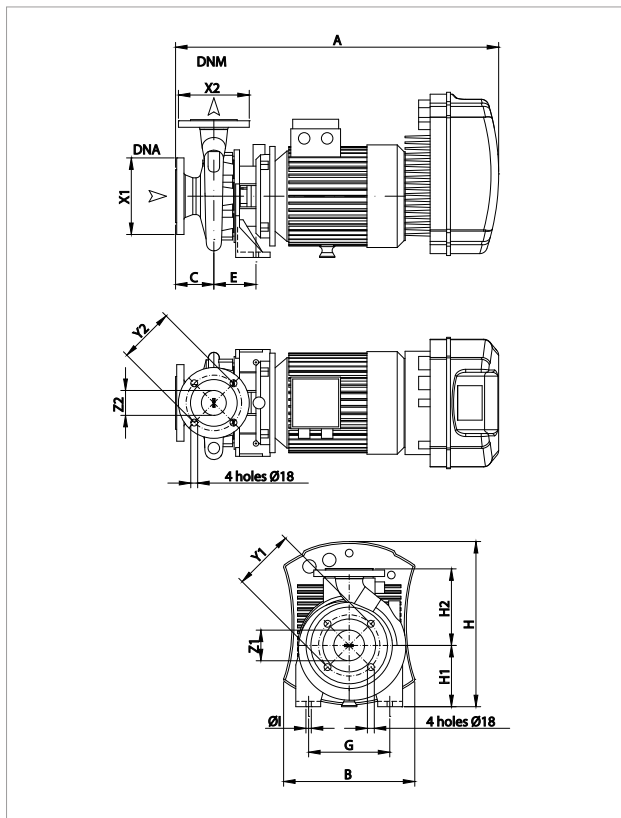

See hydraulic efficiency details on page 241.

The performance curves are based on kinematic viscosity values = 1 mm²/s and density equal to 1000 kg/m³. Curve tolerance according to ISO 9906.

MODEL	ELECTRICAL DATA					
	POWER INPUT 50 Hz	P1 MAX kW	P2 NOMINAL		In A	r.p.m.
			kW	HP		
KE 35/1200 T MCE110/P	3 x 400 V	11,4	12	15	25,10	2946

MODEL	A	B	C	E	G	I	H	H1	H2	DNA			DNM			PACKING DIMENSIONS			VOLUME (m ³)	WEIGHT kg		
										X1	Y1	Z1	X2	Y2	Z2	L/A	L/B	H				
KE 35/1200 T MCE110/P	858	341	100	110	212	14	428	160	225	-	200	160	80	-	185	145	65	1026	530	546	0,297	112,9

KE DOUBLE-IMPELLER

DOUBLE-IMPELLER CENTRIFUGAL ELECTRIC PUMPS WITH MCE/P INVERTER



TECHNICAL DATA

Operating range: from 2 to 30 m³/h with head of up to 95 metres.

Liquid temperature range:

from -10 °C to +50 °C: for KE 35/40, KE 45/50, KE 55/100,
from -15 °C to +80 °C: for KE 55/50, KE 66/100, KE 90/100, KE 70/300,
KE 80/300, KE 70/400, KE 80/400.

Pumped liquid: clean, free of solids and abrasives, non-viscous, non-aggressive, non-crystallised and chemically neutral, with properties similar to water.

Maximum ambient temperature: +40 °C.

Maximum operating pressure:

KE 35/40: 6 bar (600 kPa)
KE 45/50, KE 55/50: 8 bar (800 kPa)
KE 55/100, KE 66/100: 10 bar (1000 kPa)
KE 90/100, KE 70/300, KE 80/300, KE 70/400, KE 80/400: 12 bar (1200 kPa).

Protection class at the terminal board: IP 55.

Protection class: IP 44

Insulation class: F

Installation: normally in horizontal or vertical position, provided that the motor is always above the pump.

APPLICATIONS

Double-impeller centrifugal pump designed for the realisation of pressurization units in water systems and filling of pressure vessels. Suitable for sprinkler systems and other general water supply uses.

CONSTRUCTION FEATURES OF THE PUMP

Pump body and motor support in cast iron.
Opposite technopolymer impellers.
Carbon/ceramic mechanical seal.

CONSTRUCTION FEATURES OF THE MOTOR

Closed asynchronous type, external ventilation cooling.
Rotor running on permanently lubricated ball bearings, oversized to ensure low noise and durability.
Construction according to CEI 2-3.
Controlled by MCE inverter.

Standard single-phase voltage: 1x230 V / 50-60 Hz

Special version on request: three-phase 3x400 V / 50 Hz, or three-phase 3x460 V / 60 Hz

Standard three-phase voltage: 3x400 V / 50 Hz

Special version on request: 3x460 V / 60 Hz

KE DOUBLE-IMPELLER

DOUBLE-IMPELLER CENTRIFUGAL ELECTRIC PUMPS WITH MCE/P INVERTER

MCE/P INVERTER



CONSTRUCTION FEATURES OF THE ELECTRONICS: MCE/P INVERTER

The inverter continuously adjusts the rotation speed of the electric pump, keeping the pressure constant, even when the flow rate varies. The other electric pumps, also with variable speed, are activated in cascade after the first one has reached maximum speed. Through modulation, they compensate the pressure fluctuations of the system.

For every operating cycle, it is possible to switch the restart to a different pump, therefore ensuring even use of all electric pumps.

It is possible to set operation times for each individual pump, switching to another pump after such set times.

The "SP" pressure can be adjusted by the user using the "+" and "-" keys found on the MCE/P (as a rule, all the pumps are set to the same pressure value). With the new MCE/P, it is sufficient to set the data on one of the devices, and it will be automatically propagated to the other pumps of the system.

MODES OF OPERATION

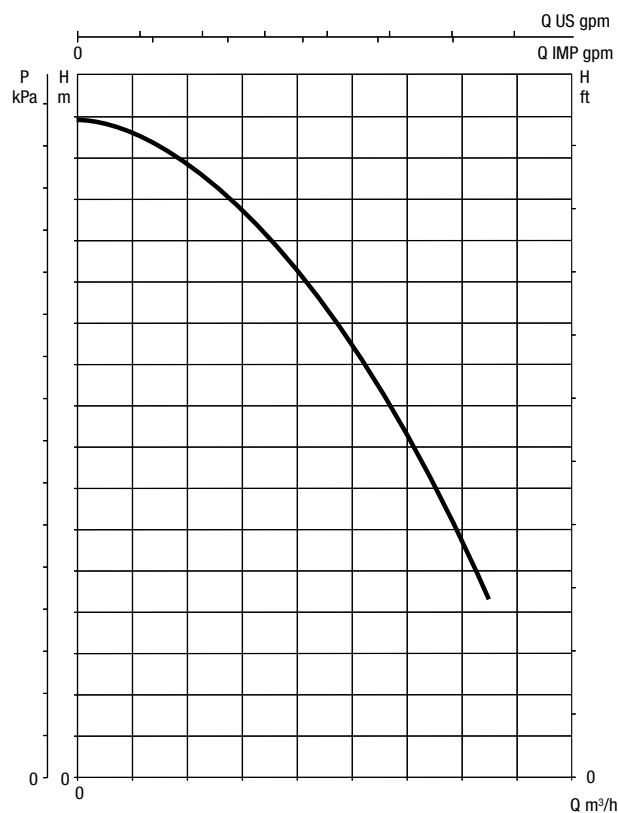

PERFORMANCE CURVES WITHOUT INVERTER

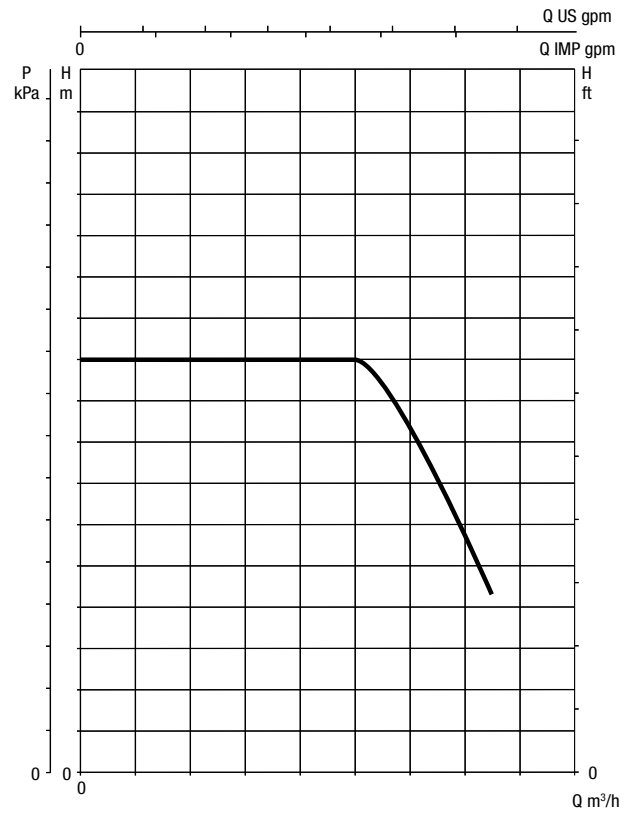

PERFORMANCE CURVES WITH INVERTER

The inverter is capable of maintaining a constant pressure even when the flow rate varies.

The operating pressure can be adjusted by the user.

A good pressure set-point is between 1/3 and 2/3 of the maximum head of the electric pump. In this way, high efficiency of the pump is maintained, together with maximum saving.

In addition, the MCE/P does not block the pump if the pressure is not reached, but the flow is present. This prevents service interruptions in case of high flows.

For more information refer to the technical appendix.

KE DOUBLE-IMPELLER

DOUBLE-IMPELLER CENTRIFUGAL ELECTRIC PUMPS WITH MCE/P INVERTER

MATERIALS

N.	PARTS	MATERIALS	MODELS
1	PUMP BODY	CAST IRON 200 UNI ISO 185	
3	SUPPORT	CAST IRON 200 UNI ISO 185	
4	IMPELLER	TECHNOPOLYMER A	K 35/40; K 45/50; K 55/100
		TECHNOPOLYMER B	K 55/50; K 66/100; K 90/100; K 70/300; K 80/300; K 70/400; K 80/400
7	SHAFT WITH ROTOR	AISI 416 STAINLESS STEEL X12CRS13 UNI 6900/71	K 35/40
		AISI 303 STAINLESS STEEL X10CRNIS 1089 UNI 6900/71	K 45/50; K 55/50; K 55/100; K66/100; K 90/100
		AISI 304 STAINLESS STEEL X5 NI 1810 UNI 6900/71	K 70/300; K 80/300; K 70/400; K 80/400
16	MECHANICAL SEAL	CARBON / CERAMIC	
28	GASKET	NBR RUBBER	K 35/40; K 45/50; K 55/50; K 55/100
34	INTERMEDIATE DISC	CAST IRON 200 UNI ISO 185	K 35/40; K 45/50; K 55/50; K 55/100; K 66/100; K 90/100; K 70/300; K 70/400; K 80/300; K 80/400

* In contact with the liquid

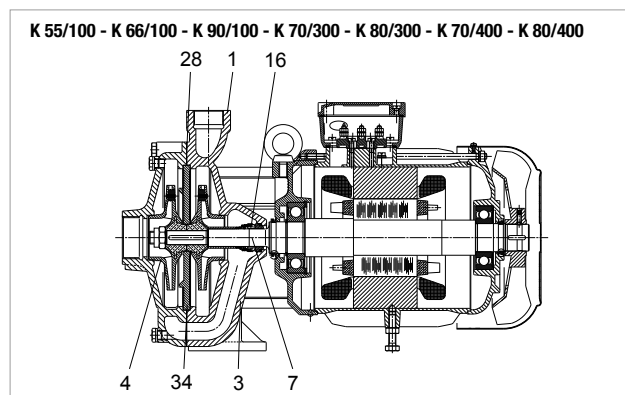
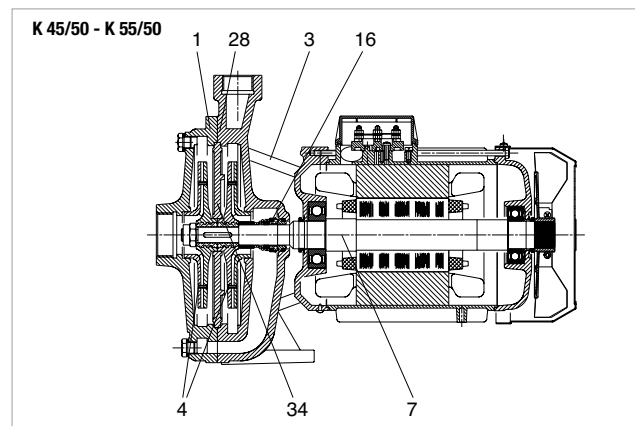
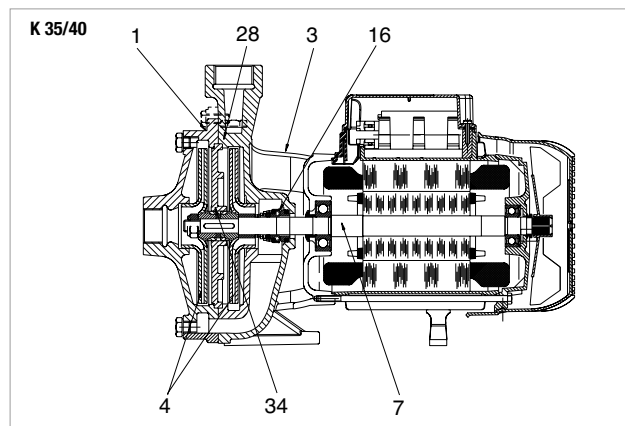

SELECTION TABLE - KE DOUBLE-PROPELLER

MODEL	Q=m ³ /h	0	1,2	1,8	2,4	3,6	4,8	6	7,2	9	9,6	10,8	12	15	18	24	30	
	Q=l/min	0	20	30	40	60	80	100	120	150	160	180	200	250	300	400	500	
KE 35/40 M MCE11/P	H (m)	43,5	41,5	40	38	33	23,5											
KE 45/50 M MCE15/P		51	49	47,5	46	42	37	30										
KE 55/50 M MCE15/P		62	60	58	57	52	45	34										
KE 55/100 T MCE30/P		62			59,5	57	54,5	51	47	39	36							
KE 66/100 T MCE30/P		73			70	67,5	64	60,5	57	49	47							
KE 90/100 T MCE55/P		83,5			82	79,5	76,5	72,5	68	61	58							
KE 70/300 T MCE55/P		76						74	73	72	71,5	70	69	65	60,5	43,5		
KE 80/300 T MCE110/P		95						93	92,2	91	90,5	90	89,5	87	82	68		
KE 70/400 T MCE110/P		86								84	83,2	82,5	82	79	76	65	47	
KE 80/400 T MCE110/P		97									95	94,5	94	92	89	80	64	

KE 35/40 - DOUBLE-IMPELLER CENTRIFUGAL ELECTRIC PUMPS WITH MCE/P INVERTER, FOR WATER SUPPLY IN DOMESTIC, CIVIL, AND INDUSTRIAL ENVIRONMENTS

Pumped liquid temperature range: from -10 °C to +50 °C - Maximum ambient temperature: +40 °C

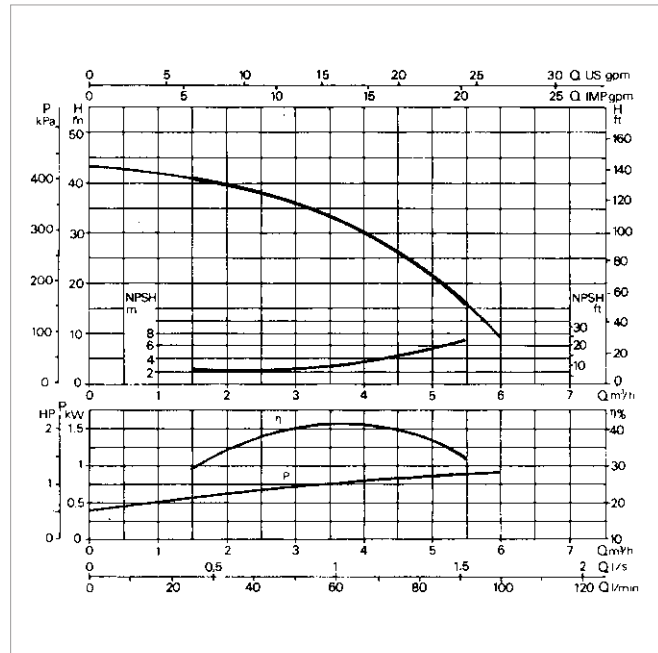
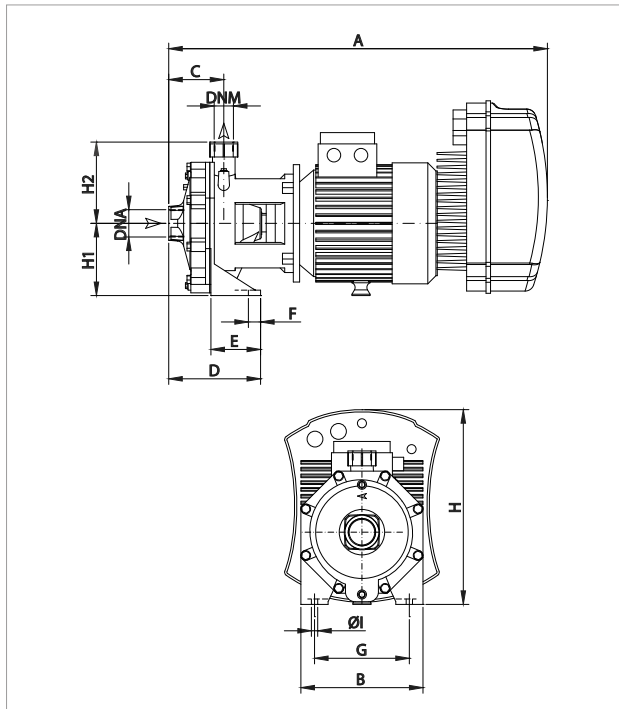

The performance curves are based on kinematic viscosity values = 1 mm²/s and density equal to 1000 kg/m³. Curve tolerance according to ISO 9906.

MODEL	ELECTRICAL DATA					
	POWER INPUT 50 Hz	P1 MAX kW	P2 NOMINAL		In A	r.p.m.
			kW	HP		
KE 35/40 M MCE11/P	1 x 230 V	1,3	0,75	1,0	10,3	2838

MODEL	A	B	C	D	E	F	G	I	H	H1	H2	DNA	DNM	PACKING DIMENSIONS			VOLUME (m³)	WEIGHT kg
														L/A	L/B	H		
KE 35/40 M MCE11/P	563	200	76	148	72	15	148	9,5	271	100	135	G 1"	G 1"	826	430	426	0,151	20,5

KE 45/50 - DOUBLE-IMPELLER CENTRIFUGAL ELECTRIC PUMPS WITH MCE/P INVERTER, FOR WATER SUPPLY IN DOMESTIC, CIVIL, AND INDUSTRIAL ENVIRONMENTS

Pumped liquid temperature range: from -10 °C to +50 °C - Maximum ambient temperature: +40 °C

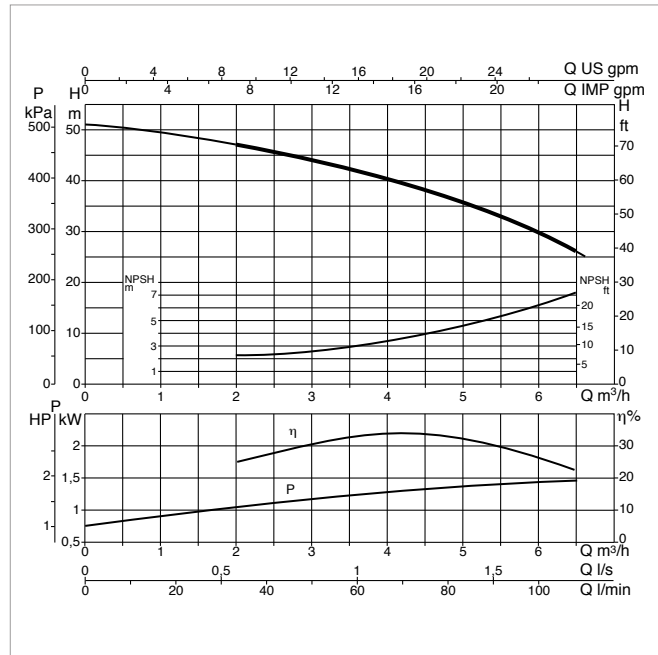
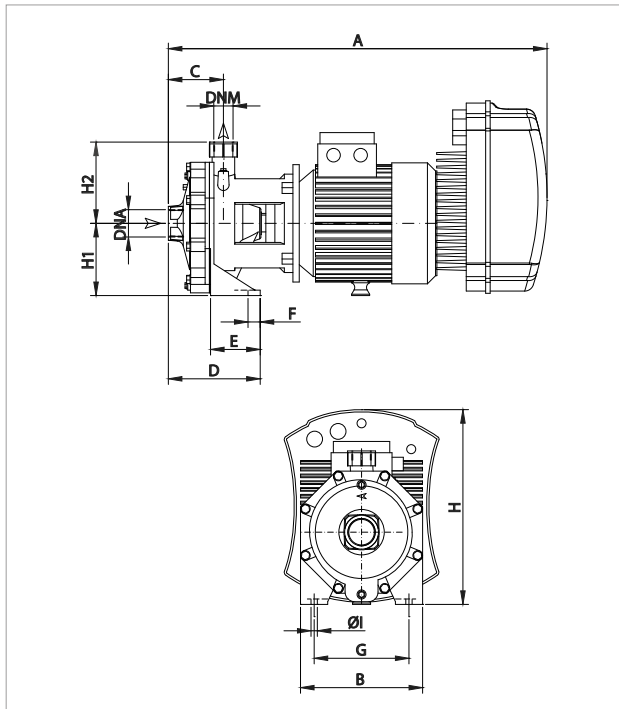

The performance curves are based on kinematic viscosity values = 1 mm²/s and density equal to 1000 kg/m³. Curve tolerance according to ISO 9906.

MODEL	ELECTRICAL DATA					
	POWER INPUT 50 Hz	P1 MAX kW	P2 NOMINAL		In A	r.p.m.
			kW	HP		
KE 45/50 M MCE15/P	1 x 230 V	2	1,6	2,2	14,7	2866

MODEL	A	B	C	D	E	F	G	I	H	H1	H2	DNA	DNM	PACKING DIMENSIONS			VOLUME (m ³)	WEIGHT kg
														L/A	L/B	H		
KE 45/50 M MCE15/P	570	210	75	144	69	15	165	11,5	289	118	150	G 1" ¼	G 1"	826	430	426	0,151	27,7

KE 55/50 - DOUBLE-IMPELLER CENTRIFUGAL ELECTRIC PUMPS WITH MCE/P INVERTER, FOR WATER SUPPLY IN DOMESTIC, CIVIL, AND INDUSTRIAL ENVIRONMENTS

Pumped liquid temperature range: from -15 °C to +80 °C - Maximum ambient temperature: +40 °C

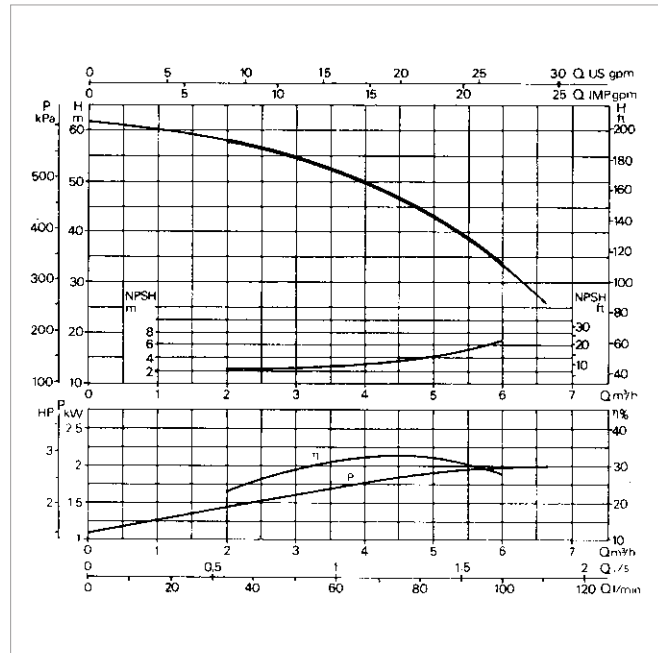
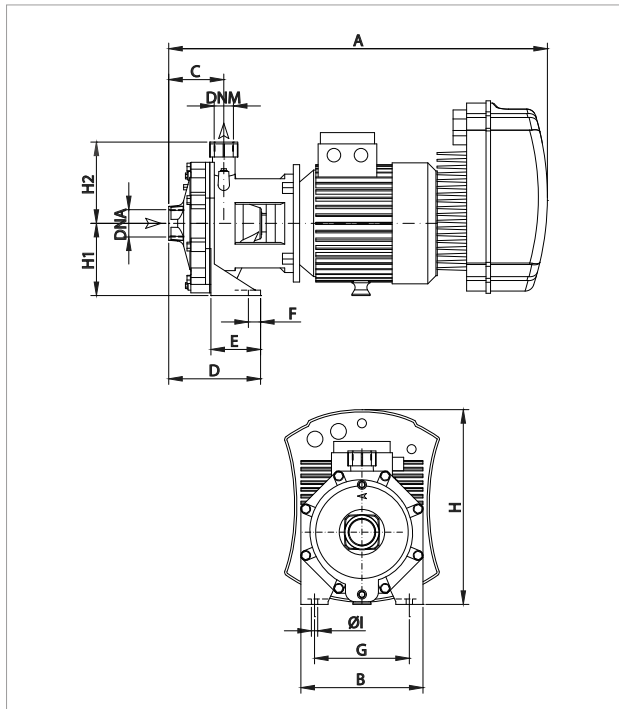

The performance curves are based on kinematic viscosity values = 1 mm²/s and density equal to 1000 kg/m³. Curve tolerance according to ISO 9906.

MODEL	ELECTRICAL DATA					
	POWER INPUT 50 Hz	P1 MAX kW	P2 NOMINAL		In A	r.p.m.
			kW	HP		
KE 55/50 M MCE15/P	1 x 230 V	2,53	1,6	2,2	18,1	2828

MODEL	A	B	C	D	E	F	G	I	H	H1	H2	DNA	DNM	PACKING DIMENSIONS			VOLUME (m³)	WEIGHT kg
														L/A	L/B	H		
KE 55/50 M MCE15/P	570	210	75	144	69	15	165	11,5	289	118	150	G 1" ¼	G 1"	826	430	426	0,151	28,2

KE 55/100 - DOUBLE-IMPELLER CENTRIFUGAL ELECTRIC PUMPS WITH MCE/P INVERTER FOR WATER SUPPLY IN DOMESTIC, CIVIL, AND INDUSTRIAL ENVIRONMENTS

Pumped liquid temperature range: from -10 °C to +50 °C - Maximum ambient temperature: +40 °C

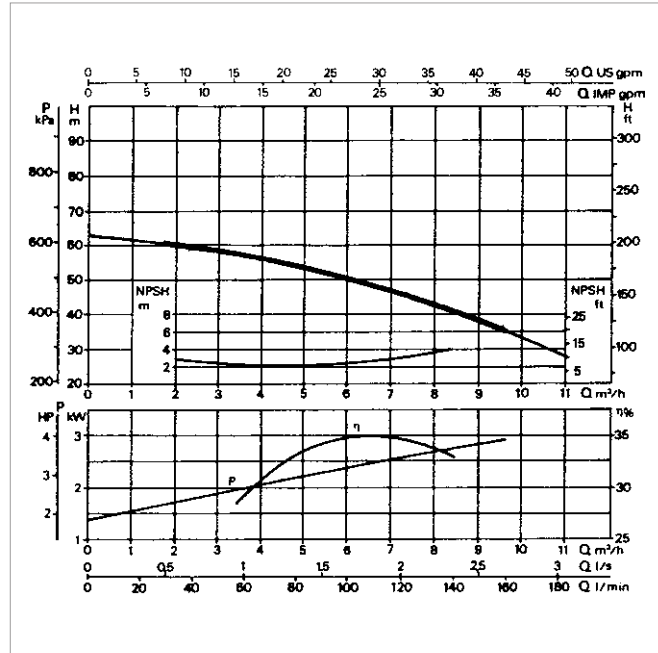
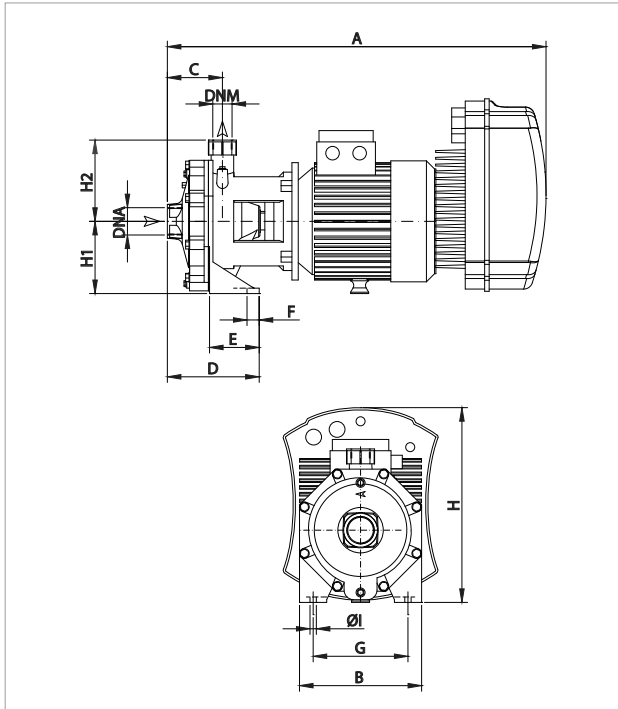

The performance curves are based on kinematic viscosity values = 1 mm²/s and density equal to 1000 kg/m³. Curve tolerance according to ISO 9906.

MODEL	ELECTRICAL DATA					
	POWER INPUT 50 Hz	P1 MAX kW	P2 NOMINAL		In A	r.p.m.
			kW	HP		
KE 55/100 T MCE30/P	3 x 400 V	3,66	2,2	3,0	8,93	2929

MODEL	A	B	C	D	E	F	G	I	H	H1	H2	DNA	DNM	PACKING DIMENSIONS			VOLUME (m ³)	WEIGHT kg
														L/A	L/B	H		
KE 55/100 T MCE30/P	650	267	88	160	72	18	200	14	362	140	172,5	G 1" ½	G 1"	826	430	426	0,151	44,9

KE 66/100 - DOUBLE-IMPELLER CENTRIFUGAL ELECTRIC PUMPS WITH MCE/P INVERTER, FOR WATER SUPPLY IN DOMESTIC, CIVIL, AND INDUSTRIAL ENVIRONMENTS

Pumped liquid temperature range: from -15 °C to +80 °C - Maximum ambient temperature: +40 °C

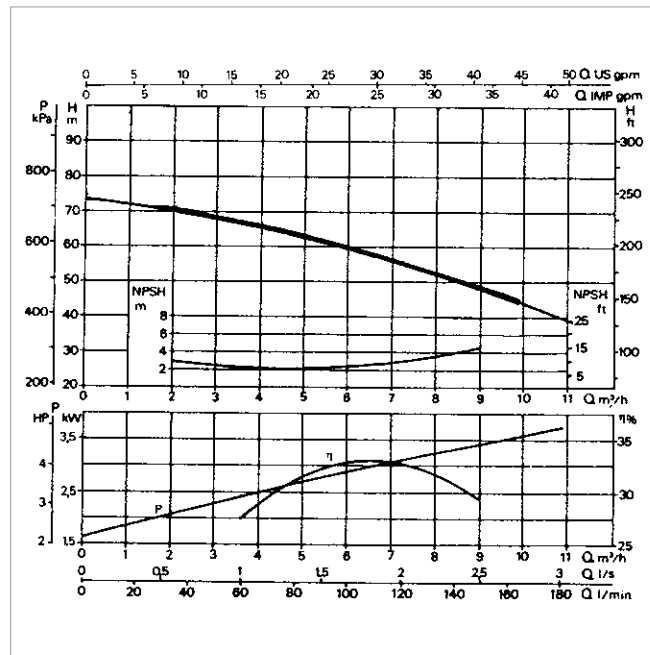
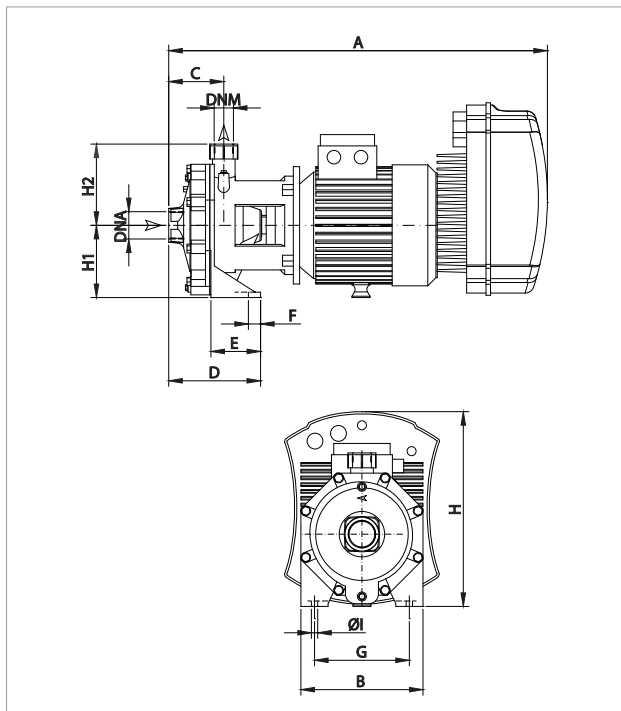

The performance curves are based on kinematic viscosity values = 1 mm²/s and density equal to 1000 kg/m³. Curve tolerance according to ISO 9906.

MODEL	ELECTRICAL DATA					
	POWER INPUT 50 Hz	P1 MAX kW	P2 NOMINAL		In A	r.p.m.
			kW	HP		
KE 66/100 T MCE30/P	3 x 400 V	4,32	3,0	4,0	9,64	2878

MODEL	A	B	C	D	E	F	G	I	H	H1	H2	DNA	DNM	PACKING DIMENSIONS			VOLUME (m³)	WEIGHT kg
														L/A	L/B	H		
KE 66/100 T MCE30/P	650	267	88	160	72	18	200	14	362	140	172,5	G 1" ½	G 1"	826	430	426	0,151	47,5

KE 90/100 - DOUBLE-IMPELLER CENTRIFUGAL ELECTRIC PUMPS WITH MCE/P INVERTER, FOR WATER SUPPLY IN DOMESTIC, CIVIL, AND INDUSTRIAL ENVIRONMENTS

Pumped liquid temperature range: from -15 °C to +80 °C - Maximum ambient temperature: +40 °C

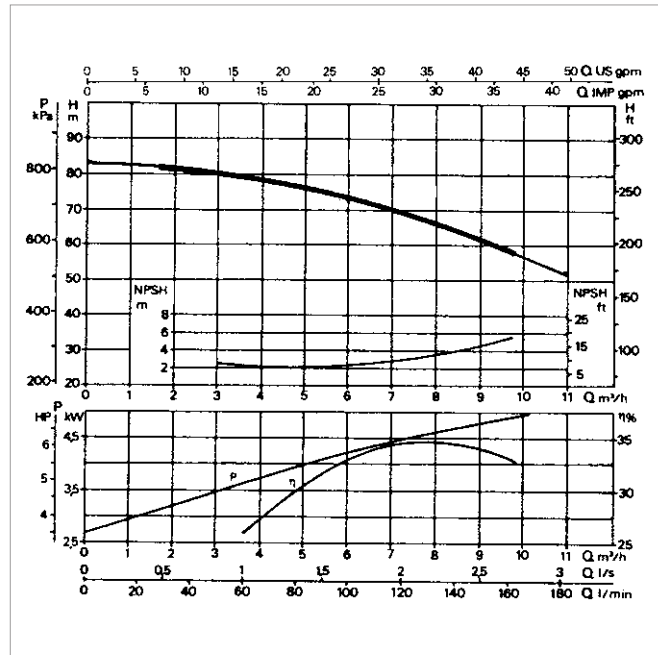
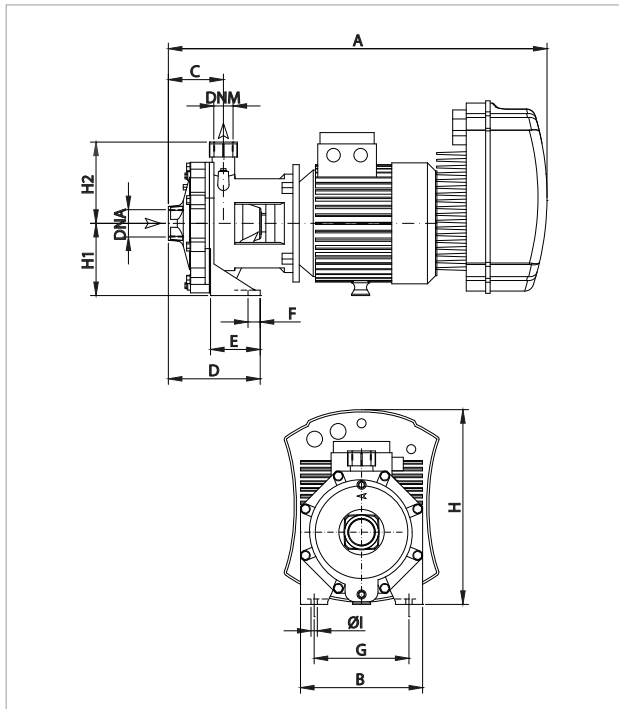

The performance curves are based on kinematic viscosity values = 1 mm²/s and density equal to 1000 kg/m³. Curve tolerance according to ISO 9906.

MODEL	ELECTRICAL DATA					
	POWER INPUT 50 Hz	P1 MAX kW	P2 NOMINAL		In A	r.p.m.
			kW	HP		
KE 90/100 T MCE55/P	3 x 400 V	5,23	3,0	4,0	10,8	2871

MODEL	A	B	C	D	E	F	G	I	H	H1	H2	DNA	DNM	PACKING DIMENSIONS			VOLUME (m ³)	WEIGHT kg
														L/A	L/B	H		
KE 90/100 T MCE55/P	650	267	88	160	72	18	200	14	362	140	172,5	G 1" ½	G 1"	826	430	426	0,151	50,8

KE 70/300 - DOUBLE-IMPELLER CENTRIFUGAL ELECTRIC PUMPS WITH MCE/P INVERTER, FOR WATER SUPPLY IN DOMESTIC, CIVIL, AND INDUSTRIAL ENVIRONMENTS

Pumped liquid temperature range: from -15 °C to +80 °C - Maximum ambient temperature: +40 °C

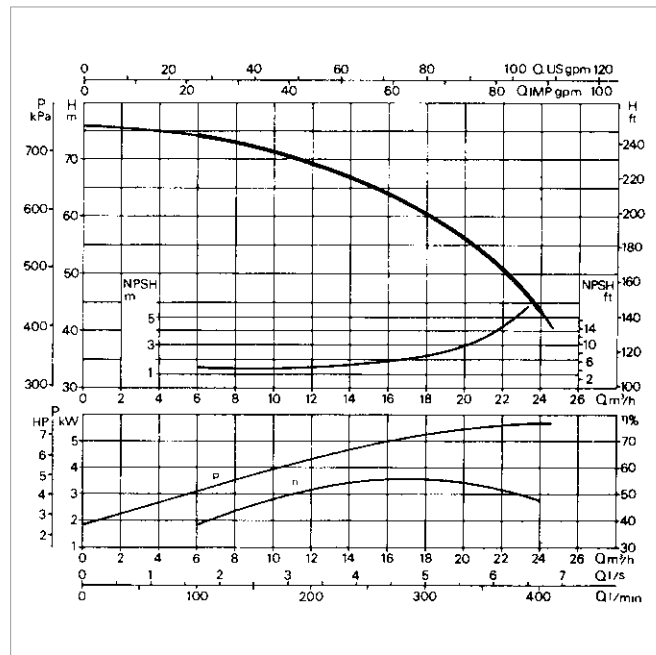
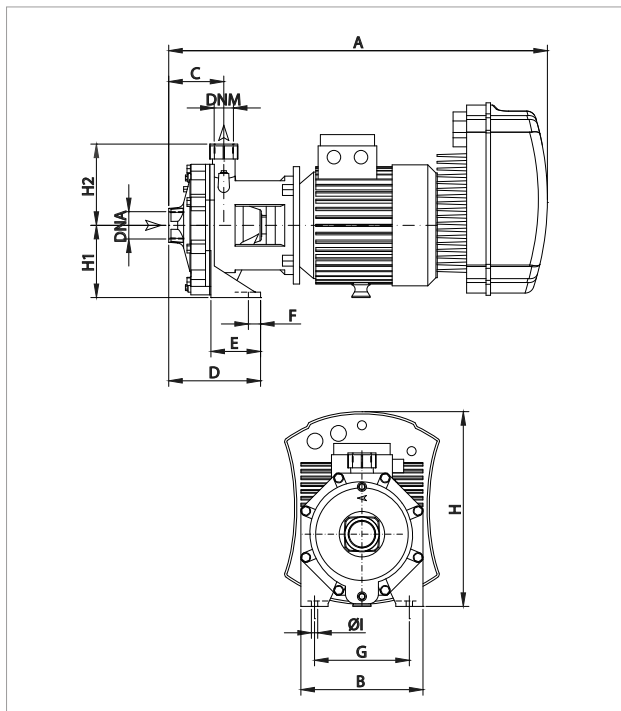

The performance curves are based on kinematic viscosity values = 1 mm²/s and density equal to 1000 kg/m³. Curve tolerance according to ISO 9906.

MODEL	ELECTRICAL DATA					
	POWER INPUT 50 Hz	P1 MAX kW	P2 NOMINAL		In A	r.p.m.
			kW	HP		
KE 70/300 T MCE55/P	3 x 400 V	6,73	5,5	7,5	14,1	2934

MODEL	A	B	C	D	E	F	G	I	H	H1	H2	DNA	DNM	PACKING DIMENSIONS			VOLUME (m³)	WEIGHT kg
														L/A	L/B	H		
KE 70/300 T MCE55/P	803	270	122	182	60	20	210	14	382	160	180	G 2"	G 1" ¼	1026	530	546	0,297	79,8

KE 80/300 - DOUBLE-IMPELLER CENTRIFUGAL ELECTRIC PUMPS WITH MCE/P INVERTER FOR WATER SUPPLY IN DOMESTIC, CIVIL, AND INDUSTRIAL ENVIRONMENTS

Pumped liquid temperature range: from -15 °C to +80 °C - Maximum ambient temperature: +40 °C

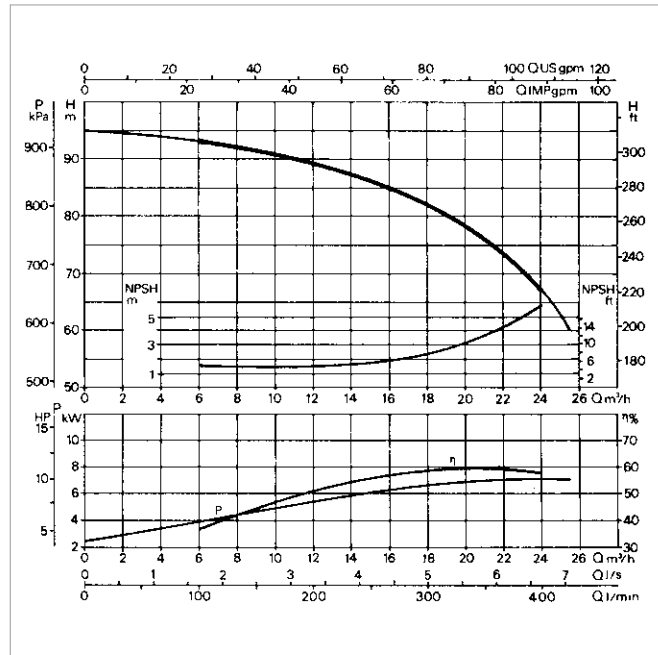
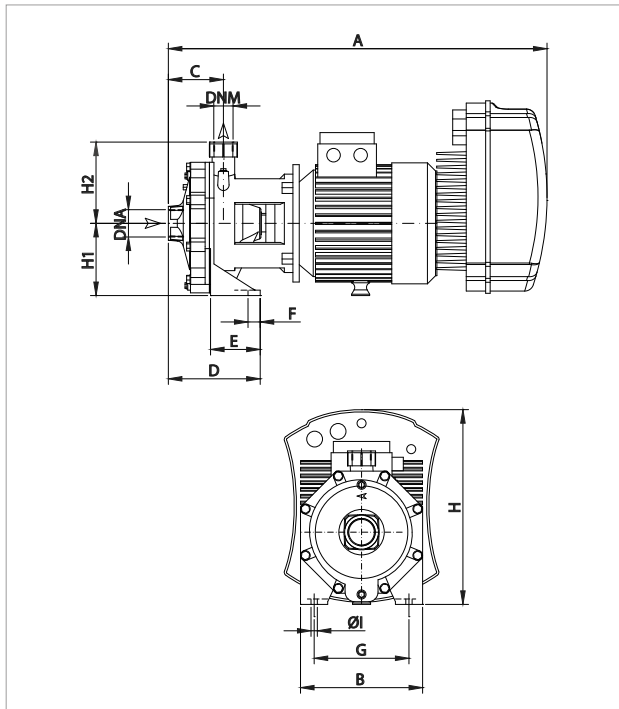

The performance curves are based on kinematic viscosity values = 1 mm²/s and density equal to 1000 kg/m³. Curve tolerance according to ISO 9906.

MODEL	ELECTRICAL DATA					
	POWER INPUT 50 Hz	P1 MAX kW	P2 NOMINAL		In A	r.p.m.
			kW	HP		
KE 80/300 T MCE110/P	3 x 400 V	9,83	7,5	10,0	19,4	2926

MODEL	A	B	C	D	E	F	G	I	H	H1	H2	DNA	DNM	PACKING DIMENSIONS			VOLUME (m ³)	WEIGHT kg
														L/A	L/B	H		
KE 80/300 T MCE110/P	853	341	122	182	60	20	210	14	382	160	180	G 2"	G 1" ¼	1026	530	546	0,297	86,6

KE 70/400 - DOUBLE-IMPELLER CENTRIFUGAL ELECTRIC PUMPS WITH MCE/P INVERTER, FOR WATER SUPPLY IN DOMESTIC, CIVIL, AND INDUSTRIAL ENVIRONMENTS

Pumped liquid temperature range: from -15 °C to +80 °C - Maximum ambient temperature: +40 °C

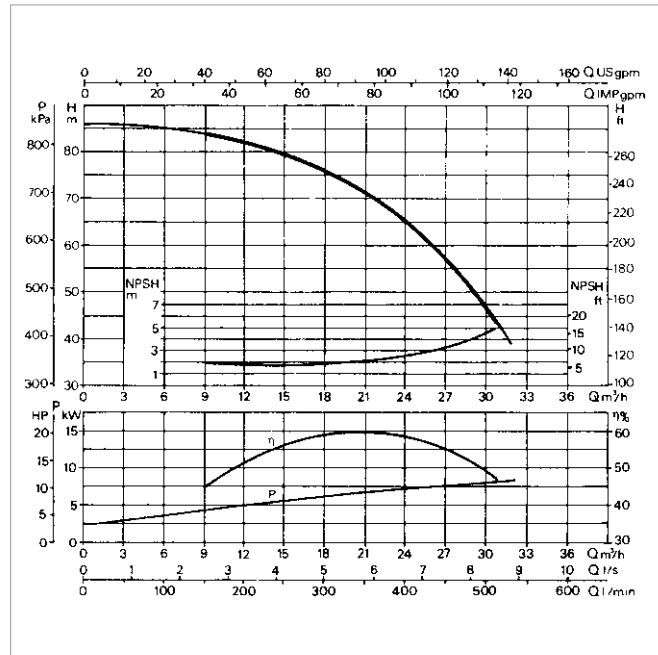
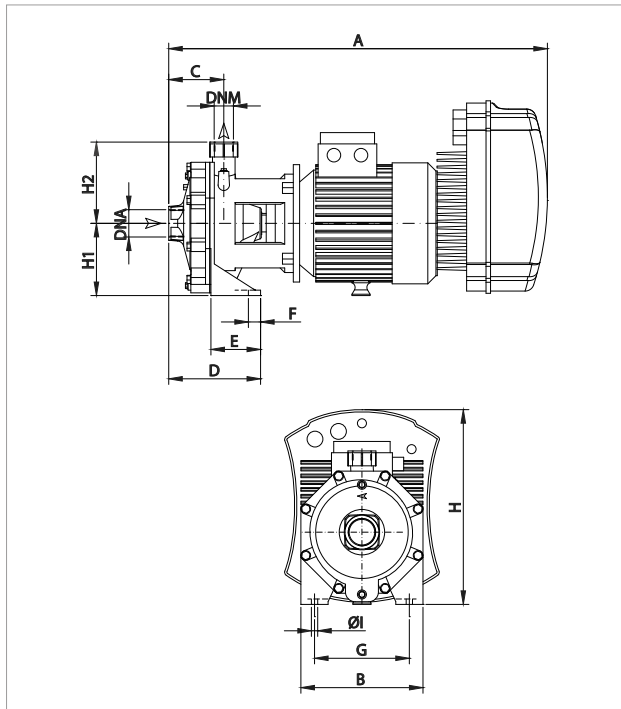

The performance curves are based on kinematic viscosity values = 1 mm²/s and density equal to 1000 kg/m³. Curve tolerance according to ISO 9906.

MODEL	ELECTRICAL DATA					
	POWER INPUT 50 Hz	P1 MAX kW	P2 NOMINAL		In A	r.p.m.
			kW	HP		
KE 70/400 T MCE110/P	3 x 400 V	9,57	9,2	12,5	20,4	2948

MODEL	A	B	C	D	E	F	G	I	H	H1	H2	DNA	DNM	PACKING DIMENSIONS			VOLUME (m³)	WEIGHT kg
														L/A	L/B	H		
KE 70/400 T MCE110/P	893	341	122	182	60	20	210	14	382	160	180	G 2"	G 1" ¼	1026	530	546	0,297	86,9

KE 80/400 - DOUBLE-IMPELLER CENTRIFUGAL ELECTRIC PUMPS WITH MCE/P INVERTER, FOR WATER SUPPLY IN DOMESTIC, CIVIL, AND INDUSTRIAL ENVIRONMENTS

Pumped liquid temperature range: from -15 °C to +80 °C - Maximum ambient temperature: +40 °C

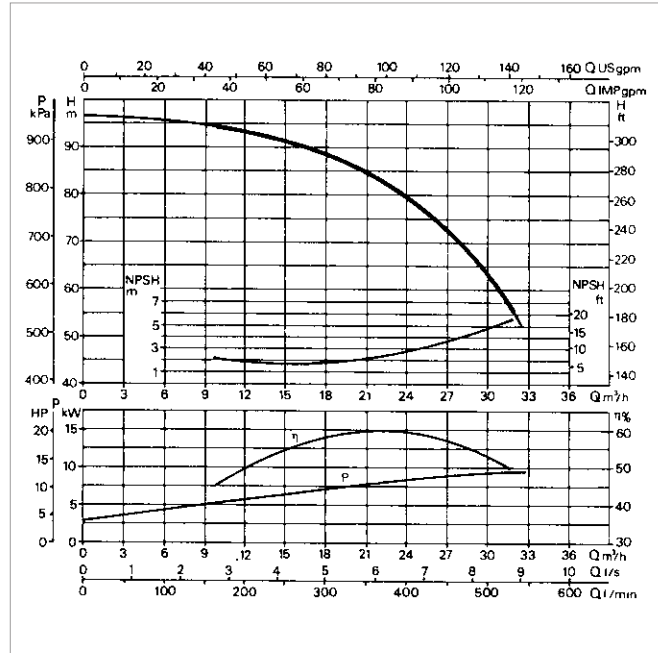
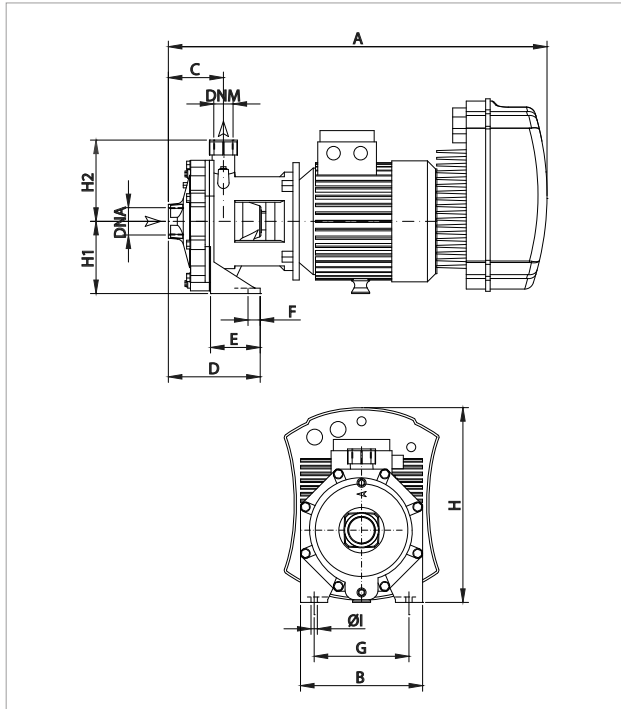

The performance curves are based on kinematic viscosity values = 1 mm²/s and density equal to 1000 kg/m³. Curve tolerance according to ISO 9906.

MODEL	ELECTRICAL DATA					
	POWER INPUT 50 Hz	P1 MAX kW	P2 NOMINAL		In A	r.p.m.
			kW	HP		
KE 80/400 T MCE110/P	3 x 400 V	11,2	11,0	15,0	22,7	2953

MODEL	A	B	C	D	E	F	G	I	H	H1	H2	DNA	DNM	PACKING DIMENSIONS			VOLUME (m ³)	WEIGHT kg
														L/A	L/B	H		
KE 80/400 T MCE110/P	893	341	122	182	60	20	210	14	382	160	180	G 2"	G 1" ¼	1026	530	546	0,297	90,9

NKM-GE / NKP-GE

STANDARDISED MONOBLOC CENTRIFUGAL ELECTRIC PUMPS WITH INVERTER



FOR CIRCULATION
SYSTEMS



FOR PRESSURIZATION
SYSTEMS



TECHNICAL DATA

Rotation speed: 1450 - 2900 1/min.

Operating range:

from 1 to 470 m³/h with head up to 72 metres.

Liquid temperature range:

from -10 °C to +140 °C (MCE/C)

from -10 °C to +80 °C (MCE/P)

Pumped liquid: clean, free of solids and abrasives, non-viscous, non-aggressive, non-crystallised and chemically neutral, with properties similar to water.

Installation: normally in horizontal or vertical position, provided that the motor is always above the pump.

Maximum ambient temperature: +40 °C.

Maximum operating pressure:

16 bar - 1600 kPa (for DN 200 max 10 bar).

Insulation class: F.

Flanging: PN 16 DIN 2533.

APPLICATIONS

Standardised centrifugal electronic pumps on base with elastic coupling, designed for a wide range of applications, such as:

MCE/C: Circulation of the hot water of the heating system, of the cold water of the air conditioning and refrigeration systems.

MCE/P: Pressure increase, supply of drinking water and sprinkler and watering systems.

CONSTRUCTION FEATURES OF THE PUMP

Cast iron single stage spiral body complying with DIN-EN 733 (formerly DIN 24255), cast iron support, flanges complying with DIN 2533, and DIN 2532 for DN 200. Cast iron impeller, closed and dynamically balanced, with compensation of the axial thrust through balancing holes, operation on interchangeable wear rings (on request). AISI 304 stainless steel pump shaft. Seal device: standardised mechanical seal according to DIN 24960 in carbon/silicon carbide with EPDM OR rings.

CONSTRUCTION FEATURES OF THE MOTOR

Closed asynchronous type motor with external ventilation, B3/B5 construction, two poles for NKP-GE and four poles for NKM-GE. Rotor running on ball bearings, largely oversized to ensure low noise and durability. For liquids with densities higher than water, motors with proportionally higher powers are required.

Construction according to CEI 2-3.

Controlled by MCE inverter.

Protection class: IP 55

Standard single-phase voltage: 1x230 V / 50-60 Hz

Special version on request: three-phase 3x400 V / 50 Hz or three-phase 3x460 V / 60 Hz

Standard three-phase voltage: 3x400 V / 50 Hz

Special version on request: 3x460 V / 60 Hz

MCE/C INVERTER

MCE-C

CONSTRUCTION FEATURES OF THE ELECTRONICS: MCE/C INVERTER

MCE/C inverters have been designed for managing circulation pumps. By allowing a simple adjustment of the differential pressure, they give the possibility of adjusting the performance of the circulation pump to the actual system requirements. They are fitted on the fan cover of the motor. This makes the installation of the pump with MCE/C particularly easy and quick. The protection class of the MCE/C is IP55. The easy of programming is guaranteed by the use of a simple and intuitive interface, similar to Dialogue electronic circulators, and a graphic display. MCE/C inverters have a double micro-processor construction that guarantees maximum efficiency and reliability.

MCE/C inverters protect the motor and the pump, and increase their life, by eliminating hammering effects and making the pump rotate at the minimum number of rotations capable of meeting the requirements of the user. In addition, electric pumps controlled by the MCE/C inverter are environmentally friendly. In fact, by ensuring that the pump only uses the power that is strictly necessary for meeting the needs of the users, electricity consumption is strongly reduced when compared with fixed speed pumps. It is possible to create twin units by using the appropriate cable for the connection of MCE/C inverters.

MODES OF OPERATION

All the functions listed below can be consulted by the users (including less experienced ones) by simply scrolling through the MCE/C menu. The calibration and the modification of the parameters are protected, and can only be completed by expert users.

1 - ΔP -c constant differential pressure adjustment mode

The ΔP -c adjustment mode keeps the differential pressure of the system constantly at the H (setp) value set, even in case of variation of the flow rate. This is the standard adjustment used. It can be set directly from the MCE/C control panel. The inverter keeps the differential pressure (H setp) constant even in case of flow variation.

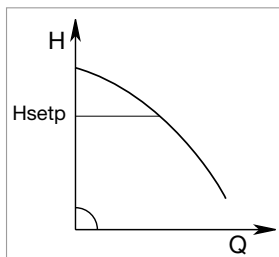

This adjustment is particularly indicated for the following systems:

- a. two-pipe heating systems with thermostat valves
- b. underfloor heating systems with thermostat valves
- c. single-pipe heating systems with thermostat valves and calibration valves
- d. systems with primary circuit pumps

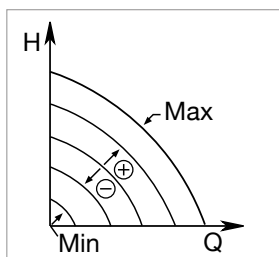

2 - Constant curve adjustment modes

2.1 - Constant curve adjustment

The rotation speed is kept at a constant number of revolutions. This rotation speed can be set between a minimum value and the nominal frequency of the circulation pump (e.g. between 15 Hz and 50 Hz). This mode can be set using the control panel on the MCE cover.

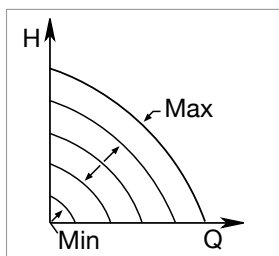

2.2 - Adjustment of the constant curve with external analogue signal

The rotation speed is kept at a constant number of revolution in proportion with the voltage of the external analogue signal.

The rotation speed changes in a linear way, between the nominal frequency of the pump when $V_{in} = 10 V$, and the minimum frequency when $V_{in} = 0 V$.

This mode can be set using the control panel on the MCE cover.

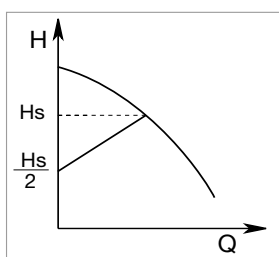

3 - ΔP -v * proportional differential pressure adjustment mode

With ΔP -v adjustment mode, with the variation of the flow rate, the value of the delivery of the head also varies in a linear manner, from Hsetp to Hsetp/2.

* in order to know the availability of the function on specific models contact our customer service.

For more information refer to the technical appendix.

NKM-GE / NKP-GE

STANDARDISED MONOBLOC CENTRIFUGAL ELECTRIC PUMPS WITH INVERTER

MCE/P INVERTER

MCE-P

CONSTRUCTION FEATURES OF THE ELECTRONICS: MCE/P INVERTER

The inverter continuously adjusts the rotation speed of the electric pump, keeping the pressure constant, even when the flow rate varies.

The other electric pumps, also with variable speed, are activated in cascade after the first one has reached maximum speed. Through modulation, they compensate the pressure fluctuations of the system.

For every operating cycle, it is possible to switch the restart to a different pump, therefore ensuring even use of all electric pumps.

It is possible to set operation times for each individual pump, switching to another pump after such set times.

The "SP" pressure can be adjusted by the user using the "+" and "-" keys found on the MCE/P (as a rule, all the pumps are set to the same pressure value). With the new MCE/P, it is sufficient to set the data on one of the devices, and it will be automatically propagated to the other pumps of the system.

MODES OF OPERATION



PERFORMANCE CURVES WITHOUT INVERTER

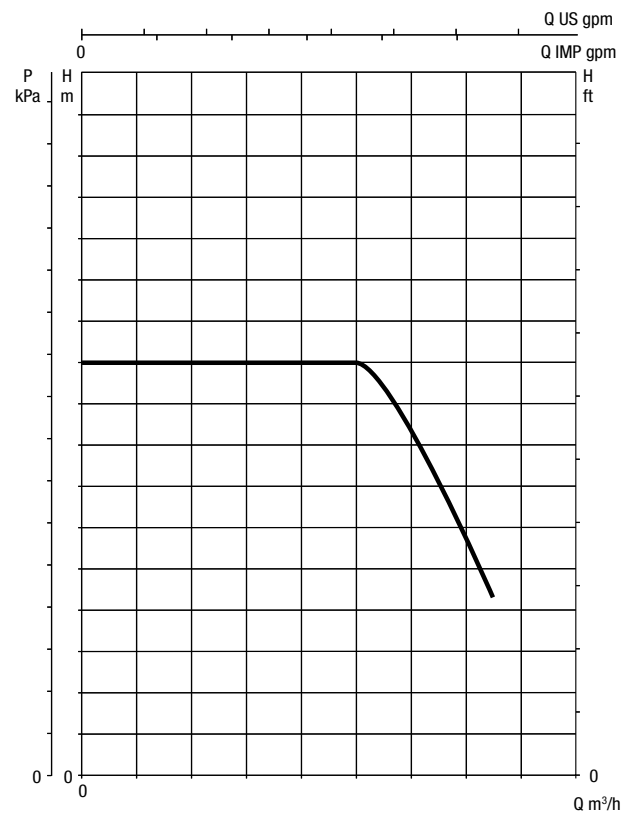

PERFORMANCE CURVES WITH INVERTER

The inverter is capable of maintaining a constant pressure even when the flow rate varies.

The operating pressure can be adjusted by the user.

A good pressure set-point is between 1/3 and 2/3 of the maximum head of the electric pump. In this way, high efficiency of the pump is maintained, together with maximum saving.

In addition, the MCE/P does not block the pump if the pressure is not reached, but the flow is present. This prevents service interruptions in case of high flows.

For more information refer to the technical appendix.

NKM-GE / NKP-GE

STANDARDISED MONOBLOC CENTRIFUGAL ELECTRIC PUMPS WITH INVERTER

MATERIALS

N.	PARTS	MATERIALS (standard version)
1	PUMP BODY	CAST IRON 250 UNI ISO 185
3	SUPPORT	CAST IRON 250 UNI ISO 185
4	IMPELLER	CAST IRON 250 UNI ISO 185
7A	PUMP SHAFT	AISI 304 STAINLESS STEEL - UNI 6900/71
16	MECHANICAL SEAL	CARBON/SILICON CARBIDE - EPDM
28	OR RING	EPDM
31	SEAL SPACER	AISI 304 STAINLESS STEEL - UNI 6900/71
36	SEAL HOLDING DISC	CAST IRON 250 UNI ISO 185
37	BLEED COCK	AISI 304 STAINLESS STEEL - UNI 6900/71

N.	PARTS	MATERIALS (version on request)
4	IMPELLER	BRONZE GCuSn5Zn5Pb5 UNI 7013/8a-72
16	MECHANICAL SEAL	SILICON CARBIDE/SILICON CARBIDE - EPDM SILICON CARBIDE/SILICON CARBIDE - VITON CARBON/SILICON CARBIDE - VITON

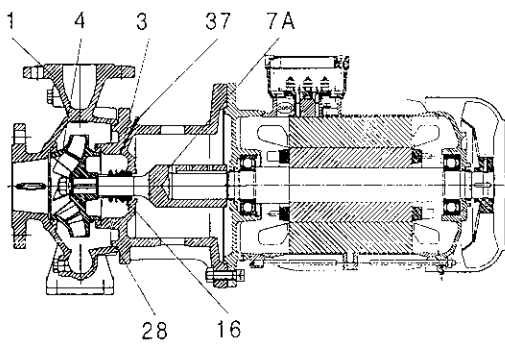
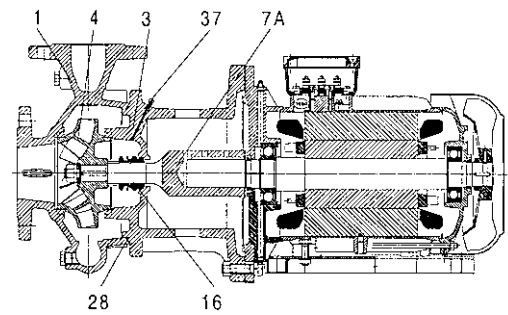
VERSION WITH MOTOR UP TO 7,5 KW INCLUDED**VERSION WITH MOTOR OVER 7,5 KW****VERSION FOR MODELS:**

NKM-G 65-315/309/11/4, NKM-G125-250/243/15/4,
NKM-G 80-250/270/11/4, NKM-G 80-315/305/15/4,
NKM-G 80-315/334/22/4, NKM-G 100-250/250/11/4,
NKM-G 150-200/218/11/4

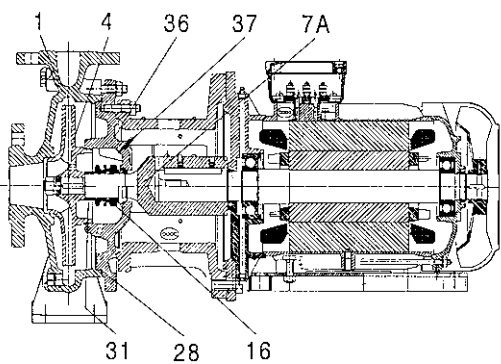

NKM-GE - 4 POLES

STANDARDISED MONOBLOC CENTRIFUGAL ELECTRIC PUMPS WITH INVERTER

SELECTION TABLE - NKM-GE 32

MODEL	Q=	0	6	12	18	24	30	36	42	48	54	60	66	72	78	84	90	102	114	
	m ³ /h	0	100	200	300	400	500	600	700	800	900	1000	1100	1200	1300	1400	1500	1700	1900	
NKM-GE 32-125.1/140/0.25/4	H (m)	6.2	5.8	4.2																
NKM-GE 32-125/142/ 0.37/4		7	6.75	5.85	4.2															
NKM-GE 32-160.1/169/0.37/4		8.9	8.2	4.6																
NKM-GE 32-160/169/0.55/4		9.4	9	7.9	5.6															
NKM-GE 32-200.1/200/0.55/4		12.7	11.2	7.2																
NKM-GE 32-200/219/ 1,1 /4		16	15.4	14.3	12.2															

SELECTION TABLE - NKM-GE 40

MODEL	Q=	0	6	12	18	24	30	36	42	48	54	60	66	72	78	84	90	102	114	
	m ³ /h	0	100	200	300	400	500	600	700	800	900	1000	1100	1200	1300	1400	1500	1700	1900	
NKM-GE 40-125/142/ 0.55/4	H (m)	6.6	6.5	6.2	5.7	4.8														
NKM-GE 40-160/166/ 0.75/4		9.2	9.2	9	8.4	7.4	5.7													
NKM-GE 40-200/219/ 1,5 /4		15.6	15.6	15.3	14.7	13.4	11.8	9.8												
NKM-GE 40-250/245/ 2,2 /4		20.6	20.5	20.1	19.2	17.8	16													
NKM-GE 40-250/260/ 3 /4		23.3	23.1	22.8	22.2	20.8	19													

SELECTION TABLE - NKM-GE 50

MODEL	Q=	0	6	12	18	24	30	36	42	48	54	60	66	72	78	84	90	102	114	
	m ³ /h	0	100	200	300	400	500	600	700	800	900	1000	1100	1200	1300	1400	1500	1700	1900	
NKM-GE 50-125/141/ 0.75/4	H (m)	6.5		6.3	6.1	5.8	5.5	5	4.5	3.9										
NKM-GE 50-160/177/ 1,5 /4		10.7		10.7	10.7	10.5	10.2	9.8	9.2	8.3										
NKM-GE 50-200/219/ 3 /4		16.8		16.8	16.5	16.1	15.5	14.6	13.6	12.4	10.9									
NKM-GE 50-250/263/ 4 /4		23.8		23.8	23.8	23.4	22.7	21.6	20.4	19	17.1									

SELECTION TABLE - NKM-GE 65

MODEL	Q=	0	6	12	18	24	30	36	42	48	54	60	66	72	78	84	90	102	114	
	m ³ /h	0	100	200	300	400	500	600	700	800	900	1000	1100	1200	1300	1400	1500	1700	1900	
NKM-GE 65-125/144/ 1,1 /4	H (m)	6.5		6.4	6.4	6.3	6.2	6	5.75	5.5	5.1	4.65	4.2	3.75						
NKM-GE 65-160/153/ 1,1 /4		7.4		7.4	7.3	7.15	6.9	6.65	6.25	5.8	5.3	4.4								
NKM-GE 65-160/177/ 2,2 /4		10.5				10.4	10.3	10.2	9.9	9.6	9.2	8.75	8.2	7.4	6.6					
NKM-GE 65-200/210/ 3 /4		15.3				15.2	15.2	15.1	14.6	14.1	13.5	12.9	12.2	11.3						
NKM-GE 65-200/219/ 4 /4		17				17	16.9	16.8	16.4	16.2	15.8	15.2	14.3	13.8	12.6					
NKM-GE 65-250/263/ 5,5 /4		24.1				23.8	23.6	23.3	22.8	22.3	21.5	20.8	19.7	18.6	17.3					
NKM-GE 65-315/279/ 7,5 /4		27							26	25.5	25	24.5	23.6	22.7	21.5	20.2	19			
NKM-GE 65-315/309/11 /4		34.2							33.2	33	32.5	32	31.5	30.7	29.8	29	28	25	21.7	

NKM-GE - 4 POLES

STANDARDISED MONOBLOC CENTRIFUGAL ELECTRIC PUMPS WITH INVERTER

SELECTION TABLE - NKM-GE 80

MODEL	Q=	0	30	36	42	48	54	60	66	72	78	84	90	102	114	120	150	180	210	240	270	300	330	360	390	420		
	m ³ /h	0	500	600	700	800	900	1000	1100	1200	1300	1400	1500	1700	1900	2000	2500	3000	3500	4000	4500	5000	5500	6000	6500	7000		
	Q=																											
	l/min																											
NKM-GE 80-160/163/ 2,2 /4	H (m)	8.65	8.5	8.45	8.3	8.15	7.9	7.7	7.4	7.2	6.9	6.65	6.3	5.7	4.9	4.6												
NKM-GE 80-160/177/ 3 /4	H (m)	10.2	10.2	10.1	10	9.9	9.75	9.65	9.5	9.25	9	8.8	8.6	7.9	7.2	6.7												
NKM-GE 80-200/222/ 5,5 /4	H (m)	16.6			16.5	16.5	16.4	16.2	16.1	16	15.7	15.4	15	14.3	13.3	12.7												
NKM-GE 80-250/240/ 7,5 /4	H (m)	20.4			20.3	20.3	20.2	20.1	20	19.9	19.8	19.5	19	18	16.7	16												
NKM-GE 80-250/270/11 /4	H (m)	25.6			25.5	25.5	25.4	25.1	25	24.8	24.6	24.2	24	23	21.5	21												
NKM-GE 80-315/305/15 /4	H (m)	32.9					32.7	32.6	32.6	32.5	32.4	32	31.6	30.5	29.5	28.9	24											

SELECTION TABLE - NKM-GE 100

MODEL	Q=	0	30	36	42	48	54	60	66	72	78	84	90	102	114	120	150	180	210	240	270	300	330	360	390	420		
	m ³ /h	0	500	600	700	800	900	1000	1100	1200	1300	1400	1500	1700	1900	2000	2500	3000	3500	4000	4500	5000	5500	6000	6500	7000		
	Q=																											
	l/min																											
NKM-GE 100-200/200/ 5,5 /4	H (m)	12.7						12.6	12.6	12.5	12.5	12.4	12.3	12	11.5	11.4	10.1	8.5										
NKM-GE 100-200/214/ 7,5 /4	H (m)	15.6						15.4	15.4	15.3	15.2	15.1	15	14.7	14.5	14.3	13.3	11.6	9.8									
NKM-GE 100-250/250/11 /4	H (m)	21.1						21	21	21	21	21	21	20.9	20	19.8	18	16										
NKM-GE 100-250/270/15 /4	H (m)	25.5						25.5	25.5	25.5	25.3	25.1	25.1	25	24.5	24	22.5	20.5	17.5									

SELECTION TABLE - NKM-GE 125

MODEL	Q=	0	30	36	42	48	54	60	66	72	78	84	90	102	114	120	150	180	210	240	270	300	330	360	390	420		
	m ³ /h	0	500	600	700	800	900	1000	1100	1200	1300	1400	1500	1700	1900	2000	2500	3000	3500	4000	4500	5000	5500	6000	6500	7000		
	Q=																											
	l/min																											
NKM-GE 125-250/243/15 /4	H (m)	19.5												19.3	19.3	19.2	19.2	18.7	17.8	16.8	15.5	14.1	12.5	10.9				

SELECTION TABLE - NKM-GE 150

MODEL	Q=	0	30	36	42	48	54	60	66	72	78	84	90	102	114	120	150	180	210	240	270	300	330	360	390	420		
	m ³ /h	0	500	600	700	800	900	1000	1100	1200	1300	1400	1500	1700	1900	2000	2500	3000	3500	4000	4500	5000	5500	6000	6500	7000		
	Q=																											
	l/min																											
NKM-GE 150-200/218/11 /4	H (m)	13.2												13.1	13	13	12.8	12.5	12.1	11.5	11	10.4	9.7	9	8	7		

NKM-GE 32-125.1 - STANDARDISED MONOBLOC CENTRIFUGAL ELECTRIC PUMPS

WITH INVERTER FOR CIRCULATION SYSTEMS



Pumped liquid temperature range: from -10 °C to +140 °C (MCE/C) - Maximum ambient temperature: +40 °C

≈ 1450 1/min

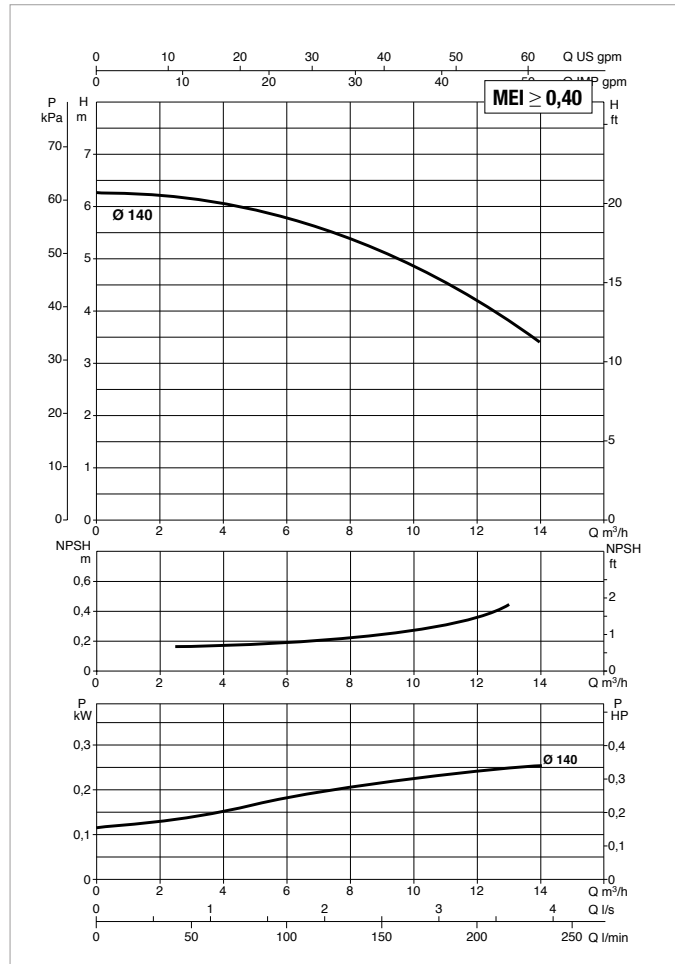
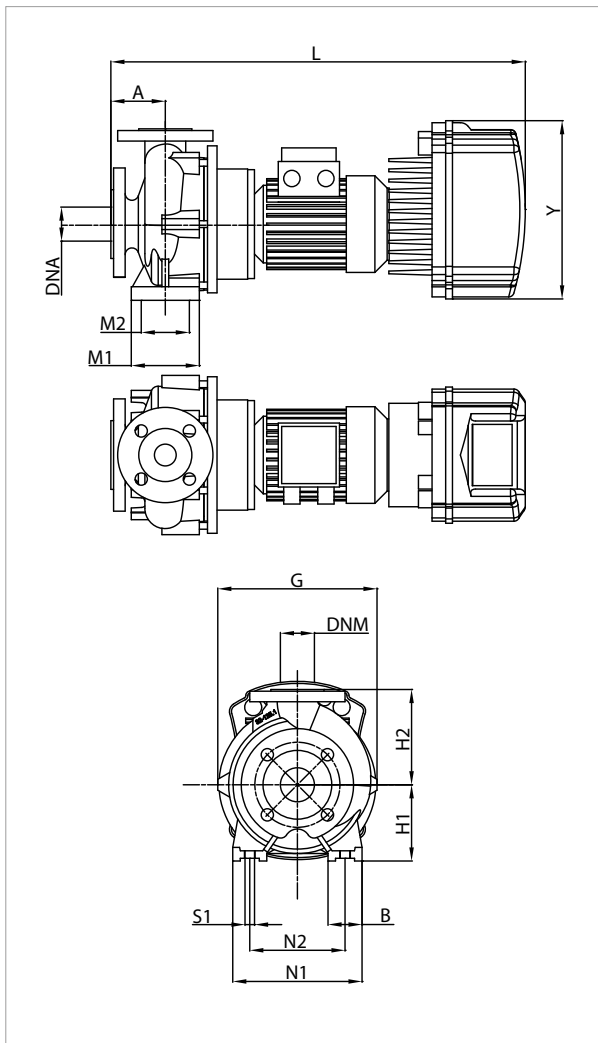

See hydraulic efficiency details on page 241.
The performance curves are based on kinematic viscosity values = 1 mm²/s and density equal to 1000 kg/m³. Curve tolerance according to ISO 9906.

MODEL	MCE MODEL	POWER INPUT 50 Hz	P2 NOMINAL		In A
			kW	HP	
NKM-GE 32-125.1/140/A/BAQE/0.25/4 M MCE11/C	MCE11/C	1 x 230 ~V	0,25	0,33	4,7

MODEL	A	B	G	H1	H2	L	M1	M2	N1	N2	S1	X	Y	DNA	DNM	PACKING DIMENSIONS			WEIGHT Kg
																L/A	L/B	H	
NKM-GE 32-125.1/140/A/BAQE/0.25/4 M MCE11/C	80	50	234	112	140	609	100	70	190	140	M10	100	262	50	32	850	500	660	36

NKM-GE 32-125 - STANDARDISED MONOBLOC CENTRIFUGAL ELECTRIC PUMPS WITH INVERTER FOR CIRCULATION SYSTEMS



Pumped liquid temperature range: from -10 °C to +140 °C (MCE/C) - Maximum ambient temperature: +40 °C

≅ 1450 1/min

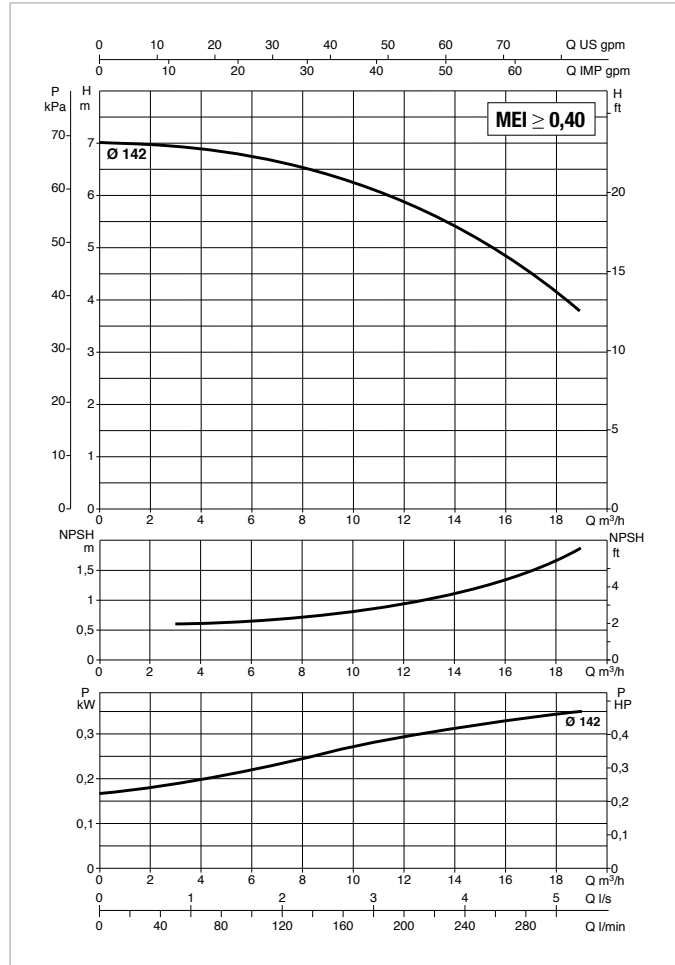
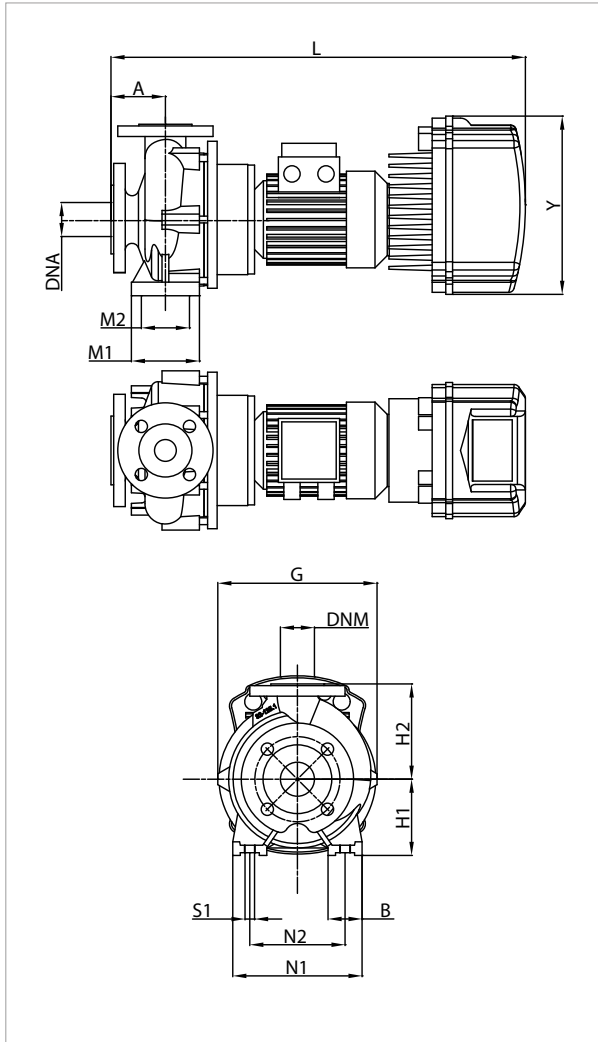

See hydraulic efficiency details on page 241.

The performance curves are based on kinematic viscosity values = 1 mm²/s and density equal to 1000 kg/m³. Curve tolerance according to ISO 9906.

MODEL	MCE MODEL	POWER INPUT 50 Hz	P2 NOMINAL		In A
			kW	HP	
NKM-GE 32-125/142/A/BAQE/0.37/4 M MCE11/C	MCE11/C	1 x 230 ~V	0,37	0,50	5,5

MODEL	A	B	G	H1	H2	L	M1	M2	N1	N2	S1	X	Y	DNA	DNM	PACKING DIMENSIONS			WEIGHT kg
																L/A	L/B	H	
NKM-GE 32-125/142/A/BAQE/0.37/4 M MCE11/C	80	50	234	112	140	609	100	70	190	140	M10	100	262	50	32	850	500	660	39

NKM-GE 32-160.1 - STANDARDISED MONOBLOC CENTRIFUGAL ELECTRIC PUMPS WITH INVERTER FOR CIRCULATION SYSTEMS



Pumped liquid temperature range: from -10 °C to +140 °C (MCE/C) - Maximum ambient temperature: +40 °C

≅ 1450 1/min

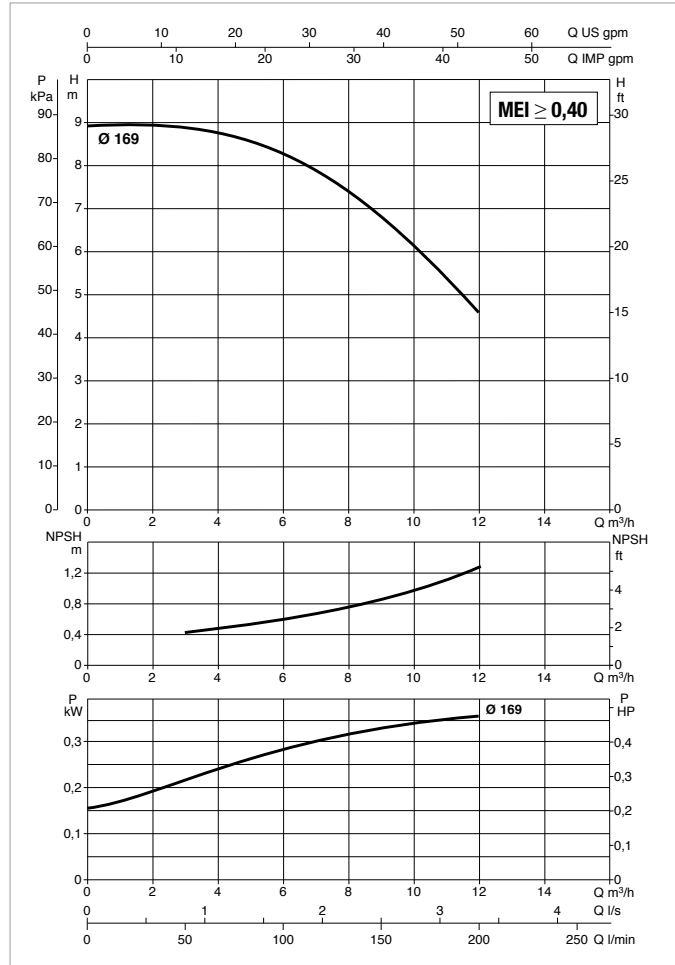
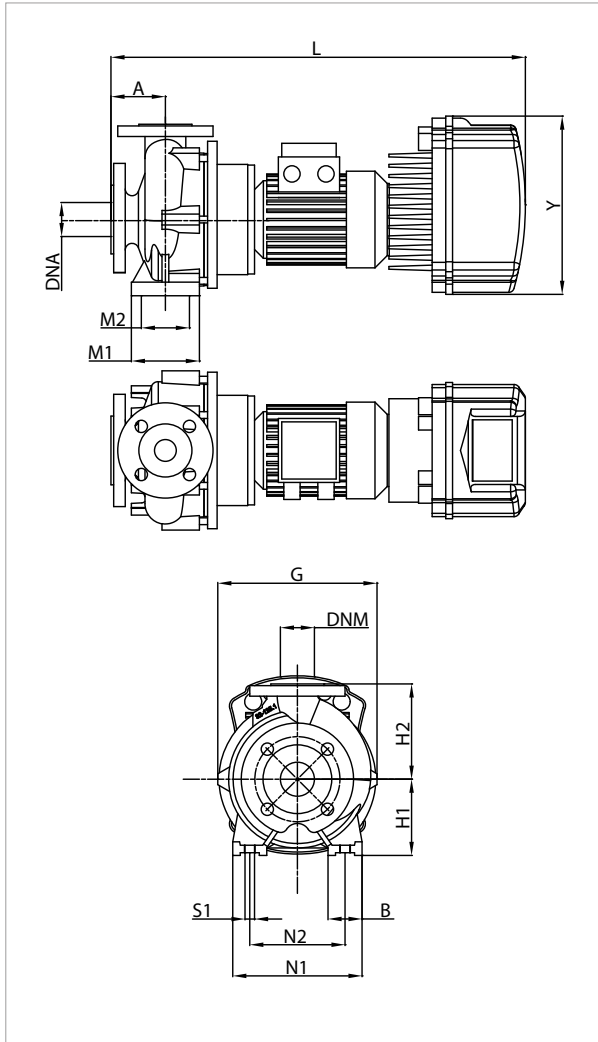

See hydraulic efficiency details on page 241.

The performance curves are based on kinematic viscosity values = 1 mm²/s and density equal to 1000 kg/m³. Curve tolerance according to ISO 9906.

MODEL	MCE MODEL	POWER INPUT 50 Hz	P2 NOMINAL		In A
			kW	HP	
NKM-GE 32-160.1/169/A/BAQE/0.37/4 M MCE11/C	MCE11/C	1 x 230 ~V	0,37	0,50	5,5

MODEL	A	B	G	H1	H2	L	M1	M2	N1	N2	S1	X	Y	DNA	DNM	PACKING DIMENSIONS			WEIGHT kg
																L/A	L/B	H	
NKM-GE 32-160.1/169/A/BAQE/0.37/4 M MCE11/C	80	50	245	132	160	609	100	70	240	190	M10	100	262	50	32	850	500	660	38

NKM-GE 32-160 - STANDARDISED MONOBLOC CENTRIFUGAL ELECTRIC PUMPS WITH INVERTER FOR CIRCULATION SYSTEMS



Pumped liquid temperature range: from -10 °C to +140 °C (MCE/C) - Maximum ambient temperature: +40 °C

≈ 1450 1/min

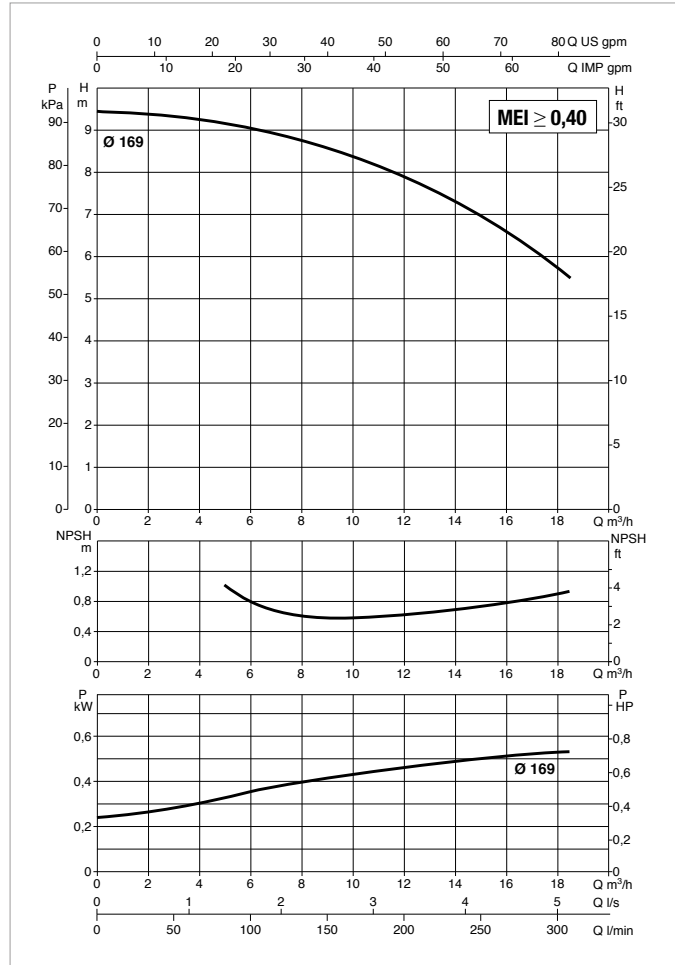
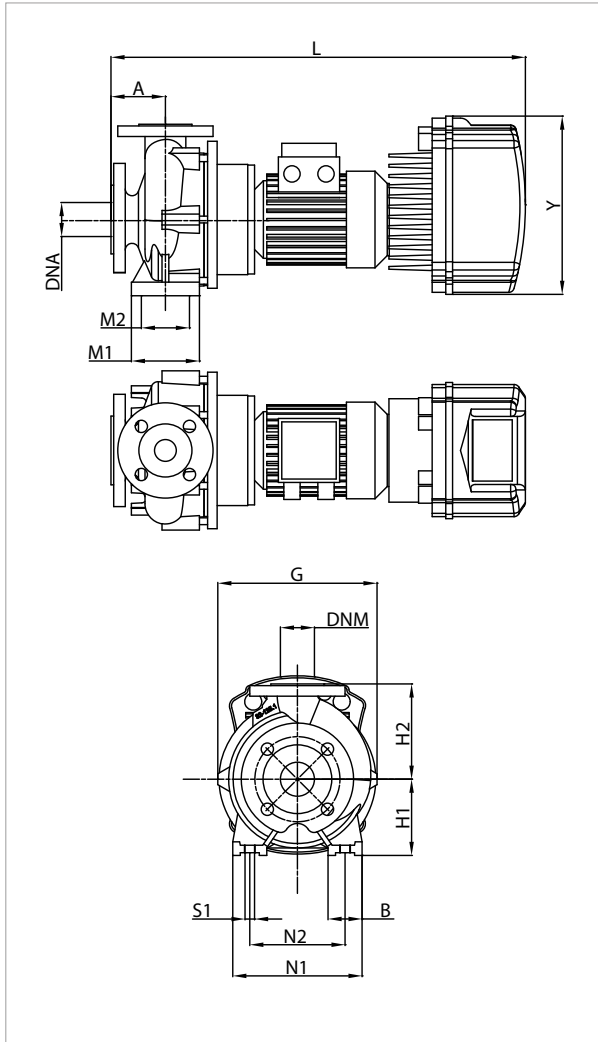

See hydraulic efficiency details on page 241.

The performance curves are based on kinematic viscosity values = 1 mm²/s and density equal to 1000 kg/m³. Curve tolerance according to ISO 9906.

MODEL	MCE MODEL	POWER INPUT 50 Hz	P2 NOMINAL		In A
			kW	HP	
NKM-GE 32-160/169/A/BAQE/0.55/4 M MCE11/C	MCE11/C	1 x 230 ~V	0,55	0,75	6,9

MODEL	A	B	G	H1	H2	L	M1	M2	N1	N2	S1	X	Y	DNA	DNM	PACKING DIMENSIONS			WEIGHT kg
																L/A	L/B	H	
NKM-GE 32-160/169/A/BAQE/0.55/4 M MCE11/C	80	50	245	132	160	660	100	70	240	190	M10	100	262	50	32	850	500	660	46

NKM-GE 32-200.1 - STANDARDISED MONOBLOC CENTRIFUGAL ELECTRIC PUMPS WITH INVERTER FOR CIRCULATION SYSTEMS



Pumped liquid temperature range: from -10 °C to +140 °C (MCE/C) - Maximum ambient temperature: +40 °C

≈ 1450 1/min

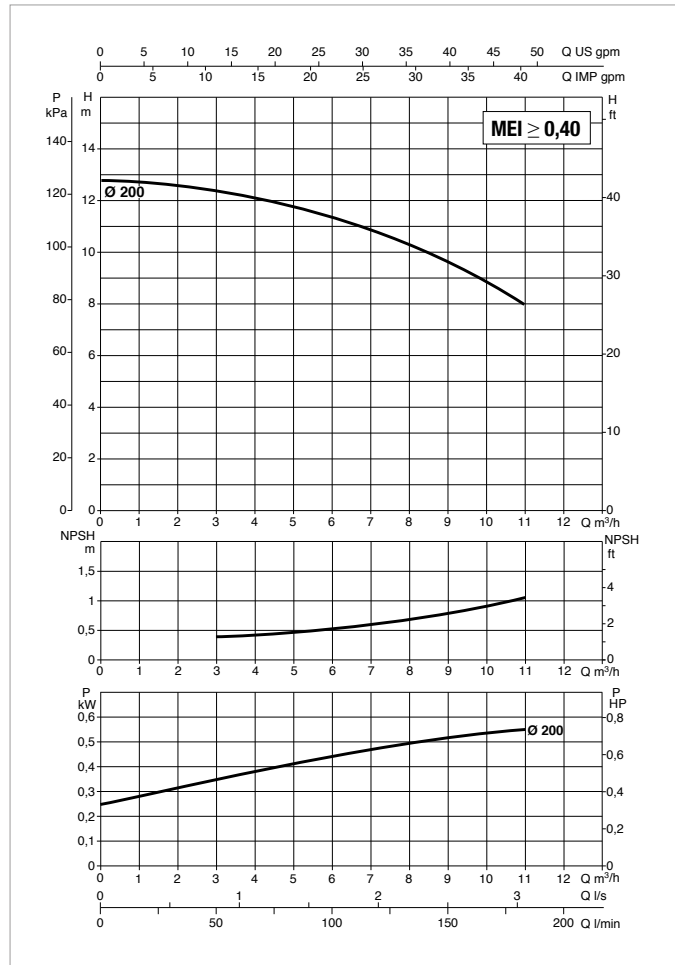
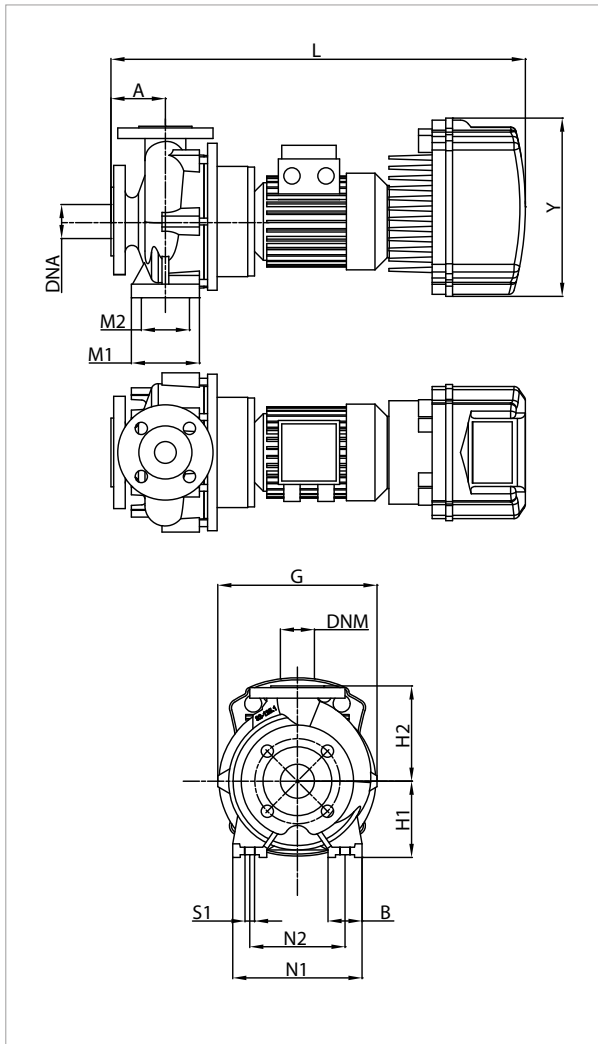

See hydraulic efficiency details on page 241.

The performance curves are based on kinematic viscosity values = 1 mm²/s and density equal to 1000 kg/m³. Curve tolerance according to ISO 9906.

MODEL	MCE MODEL	POWER INPUT 50 Hz	P2 NOMINAL		In A
			kW	HP	
NKM-GE 32-200.1/200/A/BAQE/0,55/4 M MCE11/C	MCE11/C	1 x 230 ~V	0,55	0,75	6,9

MODEL	A	B	G	H1	H2	L	M1	M2	N1	N2	S1	X	Y	DNA	DNM	PACKING DIMENSIONS			WEIGHT kg
																L/A	L/B	H	
NKM-GE 32-200.1/200/A/BAQE/0,55/4 M MCE11/C	80	50	279	160	180	660	100	70	240	190	M10	100	262	50	32	850	500	660	55

NKM-GE 32-200 - STANDARDISED MONOBLOC CENTRIFUGAL ELECTRIC PUMPS WITH INVERTER FOR CIRCULATION SYSTEMS



Pumped liquid temperature range: from -10 °C to +140 °C (MCE/C) - Maximum ambient temperature: +40 °C

≈ 1450 1/min

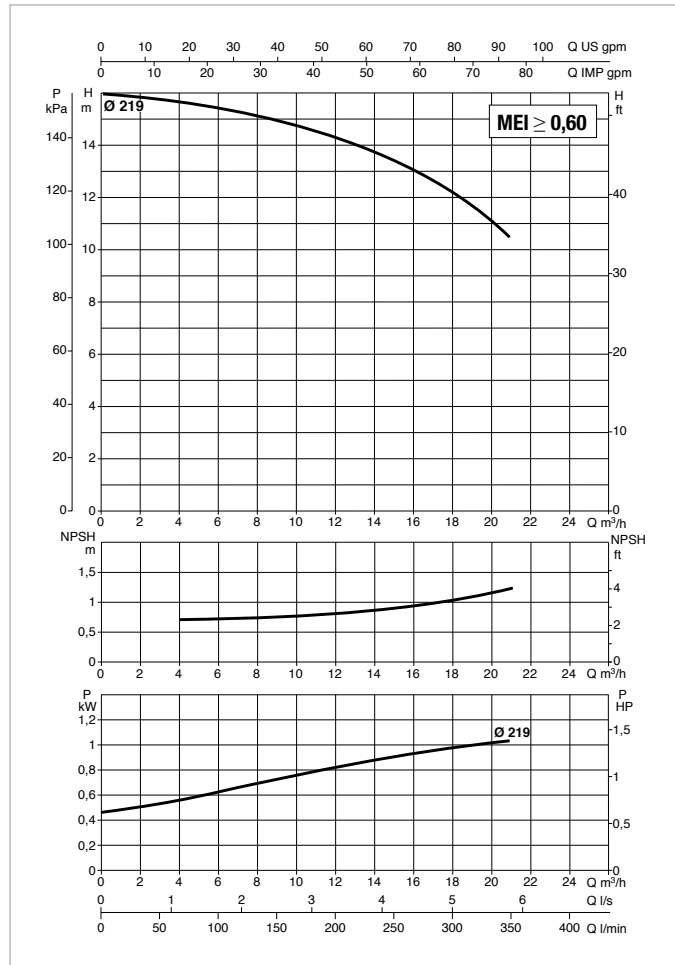
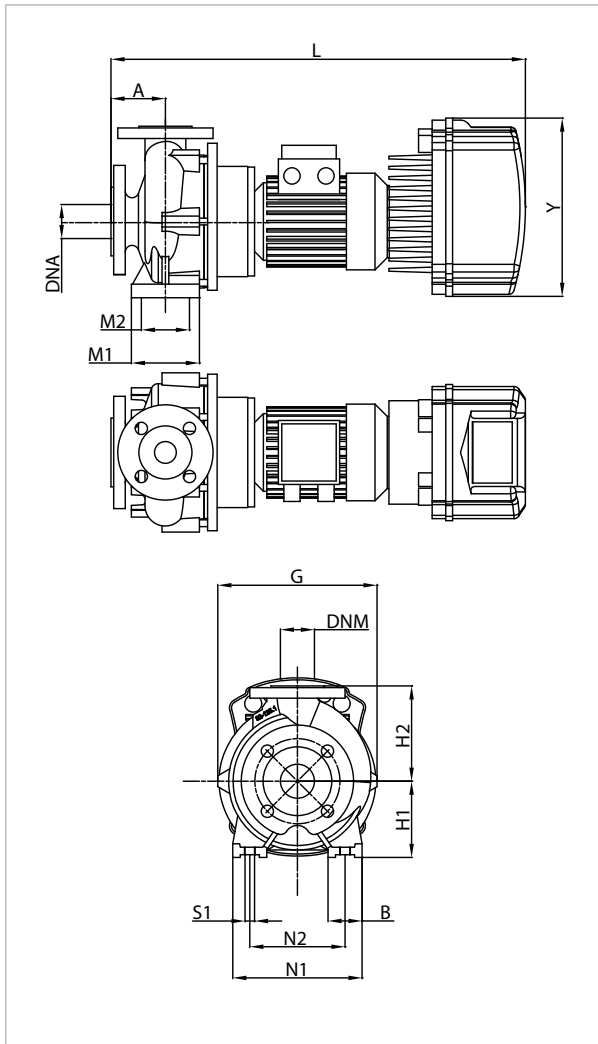

See hydraulic efficiency details on page 241.

The performance curves are based on kinematic viscosity values = 1 mm²/s and density equal to 1000 kg/m³. Curve tolerance according to ISO 9906.

MODEL	MCE MODEL	POWER INPUT 50 Hz	P2 NOMINAL		In A
			kW	HP	
NKM-GE 32-200/219/A/BAQE/1,1/4 M MCE11/C	MCE11/C	1 x 230 ~V	1,10	1,50	10,4
NKM-GE 32-200/219/A/BAQE/1,1/4 T MCE30/C	MCE30/C	3 x 400 ~V	1,10	1,50	3,2

MODEL	A	B	G	H1	H2	L	M1	M2	N1	N2	S1	X	Y	DNA	DNM	PACKING DIMENSIONS			WEIGHT kg
																L/A	L/B	H	
NKM-GE 32-200/219/A/BAQE/1,1/4 M MCE11/C	80	50	279	160	180	673	100	70	240	190	M10	100	262	50	32	850	500	660	66
NKM-GE 32-200/219/A/BAQE/1,1/4 T MCE30/C	80	50	279	160	180	740	100	70	240	190	M10	100	353	50	32	850	500	660	68,6

NKM-GE 40-125 - STANDARDISED MONOBLOC CENTRIFUGAL ELECTRIC PUMPS WITH INVERTER FOR CIRCULATION SYSTEMS



Pumped liquid temperature range: from -10 °C to +140 °C (MCE/C) - Maximum ambient temperature: +40 °C

≈ 1450 1/min

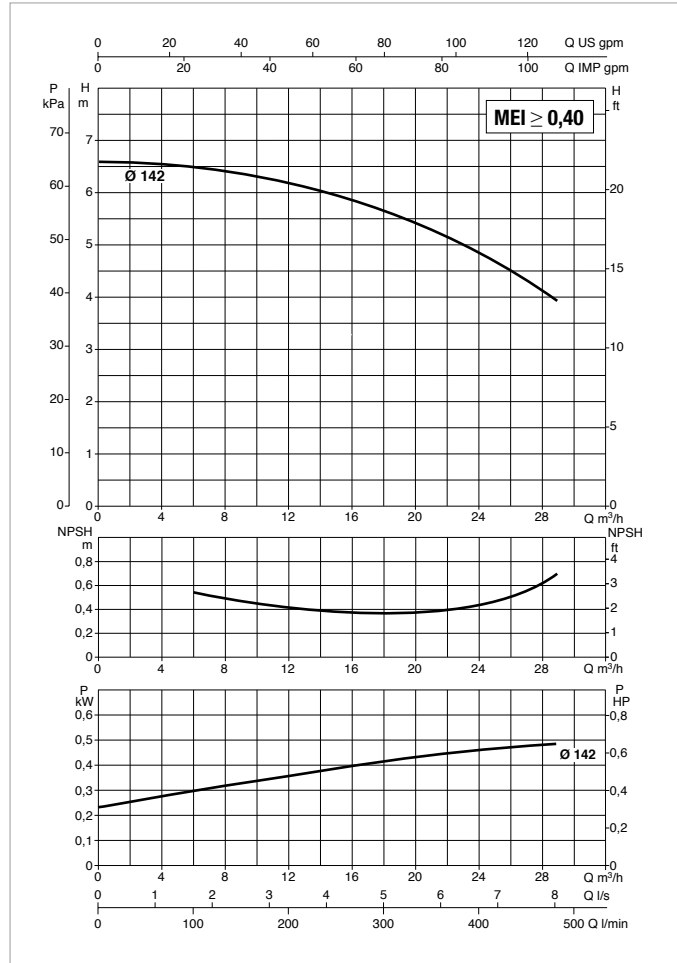
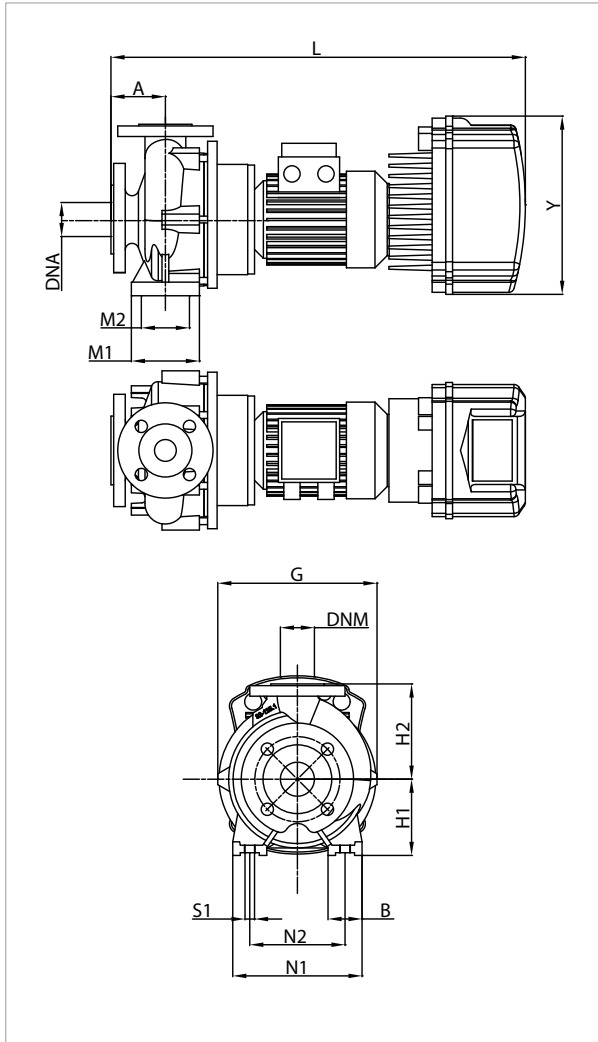

See hydraulic efficiency details on page 241.

The performance curves are based on kinematic viscosity values = 1 mm²/s and density equal to 1000 kg/m³. Curve tolerance according to ISO 9906.

MODEL	MCE MODEL	POWER INPUT 50 Hz	P2 NOMINAL		In A
			kW	HP	
NKM-GE 40-125/142/A/BAQE/0.55/4 M MCE11/C	MCE11/C	1 x 230 ~V	0,55	0,75	6,9

MODEL	A	B	G	H1	H2	L	M1	M2	N1	N2	S1	X	Y	DNA	DNM	PACKING DIMENSIONS			WEIGHT kg
																L/A	L/B	H	
NKM-GE 40-125/142/A/BAQE/0.55/4 M MCE11/C	80	50	235	112	140	635	100	70	210	160	M10	100	262	65	40	850	500	660	51

NKM-GE 40-160 - STANDARDISED MONOBLOC CENTRIFUGAL ELECTRIC PUMPS WITH INVERTER FOR CIRCULATION SYSTEMS



Pumped liquid temperature range: from -10 °C to +140 °C (MCE/C) - Maximum ambient temperature: +40 °C

≅ 1450 1/min

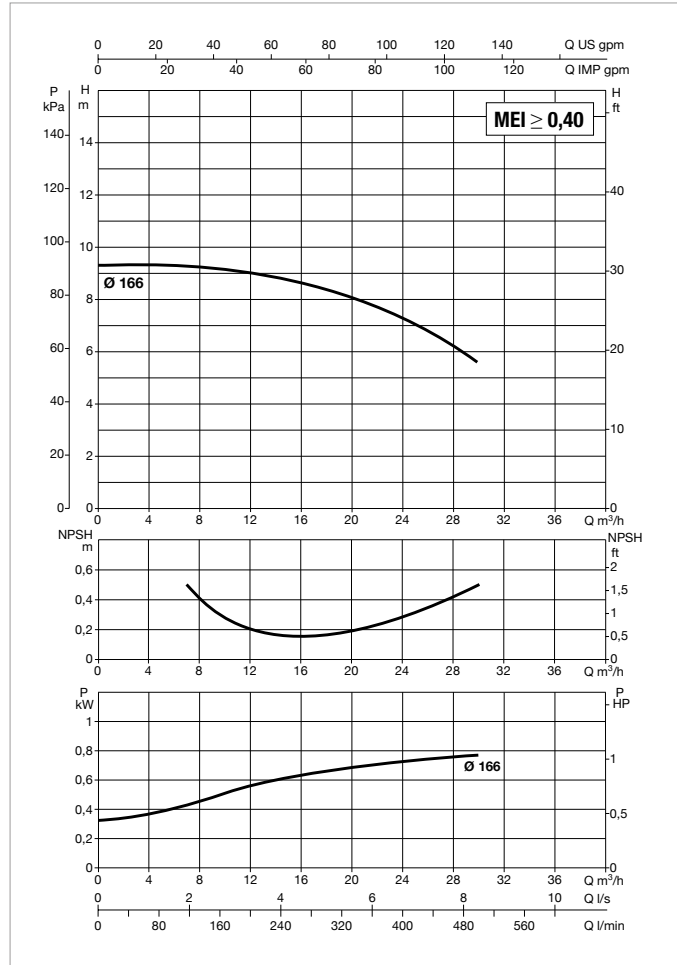
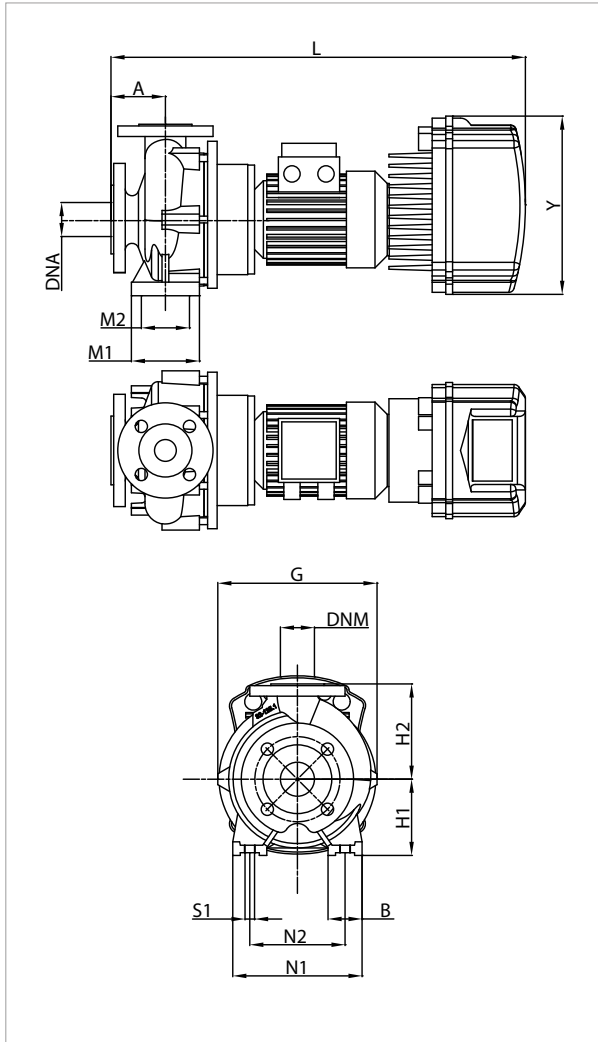

See hydraulic efficiency details on page 241.

The performance curves are based on kinematic viscosity values = 1 mm²/s and density equal to 1000 kg/m³. Curve tolerance according to ISO 9906.

MODEL	MCE MODEL	POWER INPUT 50 Hz	P2 NOMINAL		In A
			kW	HP	
NKM-GE 40-160/166/A/BAQE/0.75/4 M MCE11/C	MCE11/C	1 x 230 ~V	0,75	1,00	9,9
NKM-GE 40-160/166/A/BAQE/0,75/4 T MCE30/C	MCE30/C	3 x 400 ~V	0,75	1,00	2,7

MODEL	A	B	G	H1	H2	L	M1	M2	N1	N2	S1	X	Y	DNA	DNM	PACKING DIMENSIONS			WEIGHT kg
																L/A	L/B	H	
NKM-GE 40-160/166/A/BAQE/0.75/4 M MCE11/C	80	50	253	132	160	660	100	70	240	190	M10	100	262	65	40	850	500	660	54
NKM-GE 40-160/166/A/BAQE/0.75/4 T MCE30/C	80	50	253	132	160	727	100	70	240	190	M10	100	353	65	40	850	500	660	56,6

NKM-GE 40-200 - STANDARDISED MONOBLOC CENTRIFUGAL ELECTRIC PUMPS WITH INVERTER FOR CIRCULATION SYSTEMS



Pumped liquid temperature range: from -10 °C to +140 °C (MCE/C) - Maximum ambient temperature: +40 °C

≈ 1450 1/min

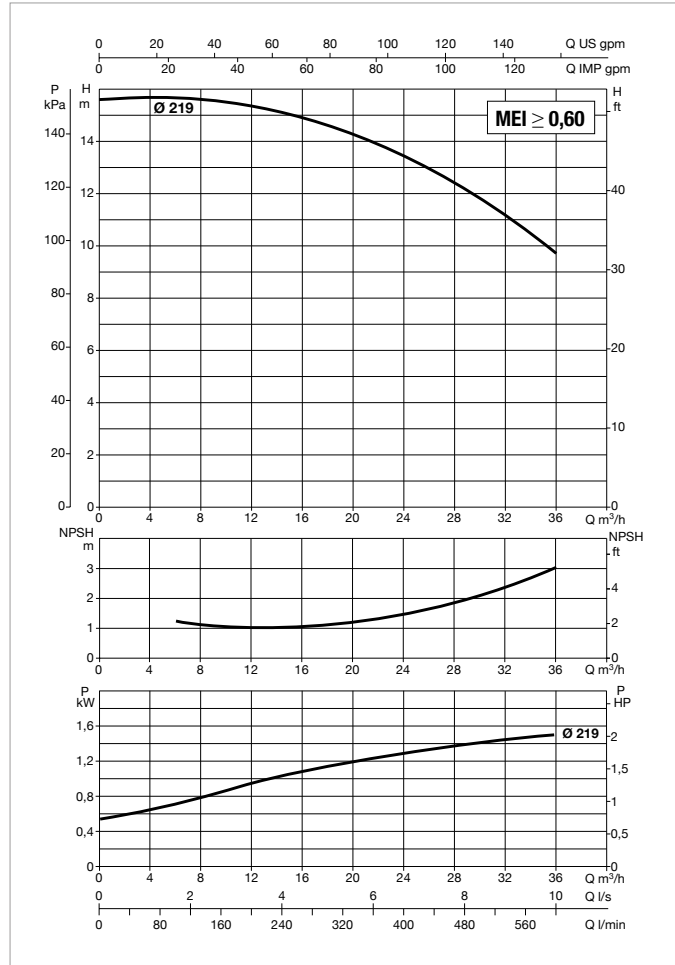
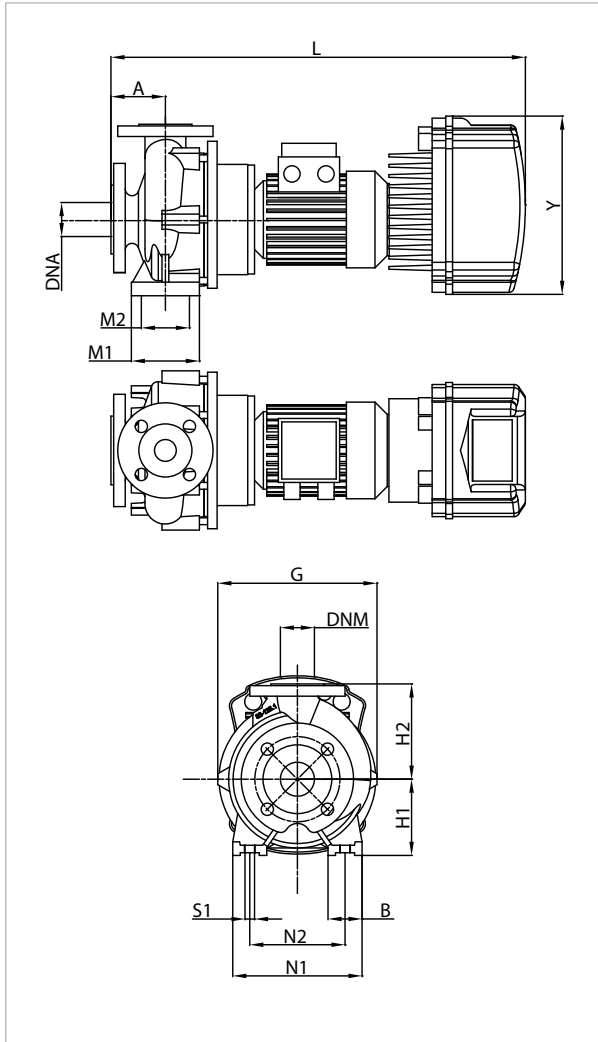

See hydraulic efficiency details on page 241.

The performance curves are based on kinematic viscosity values = 1 mm²/s and density equal to 1000 kg/m³. Curve tolerance according to ISO 9906.

MODEL	MCE MODEL	POWER INPUT 50 Hz	P2 NOMINAL		In A
			kW	HP	
NKM-GE 40-200/219/A/BAQE/1,5/4 M MCE15/C	MCE15/C	1 x 230 ~V	1,50	2,00	14,0
NKM-GE 40-200/219/A/BAQE/1,5 /4 T MCE30/C	MCE30/C	3 x 400 ~V	1,50	2,00	4,5

MODEL	A	B	G	H1	H2	L	M1	M2	N1	N2	S1	X	Y	DNA	DNM	PACKING DIMENSIONS			WEIGHT kg
																L/A	L/B	H	
NKM-GE 40-200/219/A/BAQE/1,5/4 M MCE15/C	100	50	296	160	180	718	100	70	265	212	M10	100	262	65	40	850	500	660	70
NKM-GE 40-200/219/A/BAQE/1,5 /4 T MCE30/C	100	50	296	160	180	785	100	70	265	212	M10	100	353	65	40	850	500	660	72,6

NKM-GE 40-250 - STANDARDISED MONOBLOC CENTRIFUGAL ELECTRIC PUMPS WITH INVERTER FOR PRESSURISATION SYSTEMS



Pumped liquid temperature range: from -10 °C to +80 °C (MCE/P) - Maximum ambient temperature: +40 °C

≅ 1450 1/min

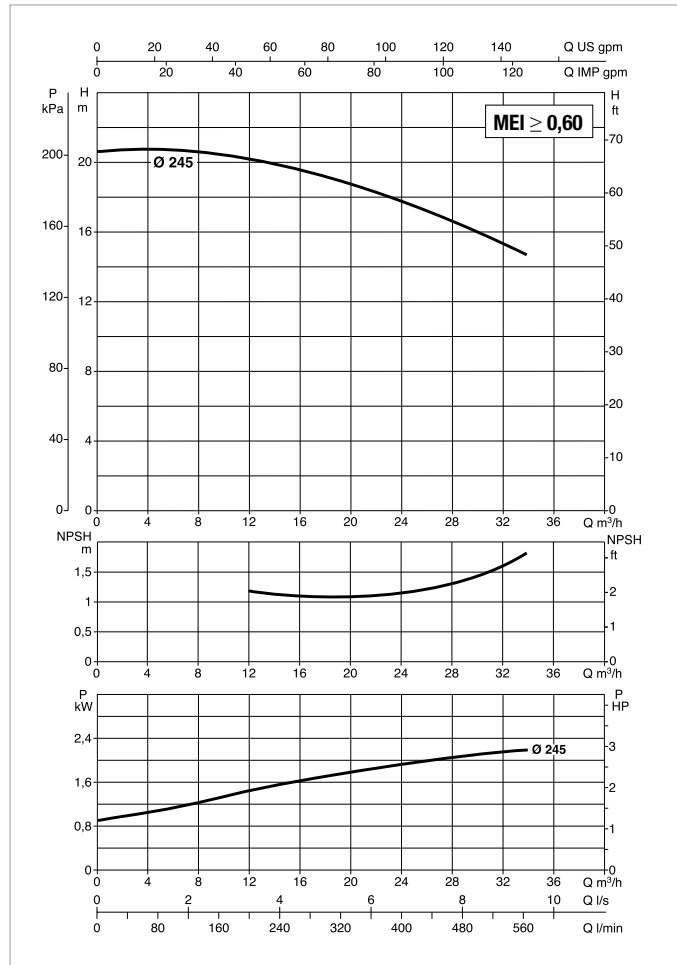
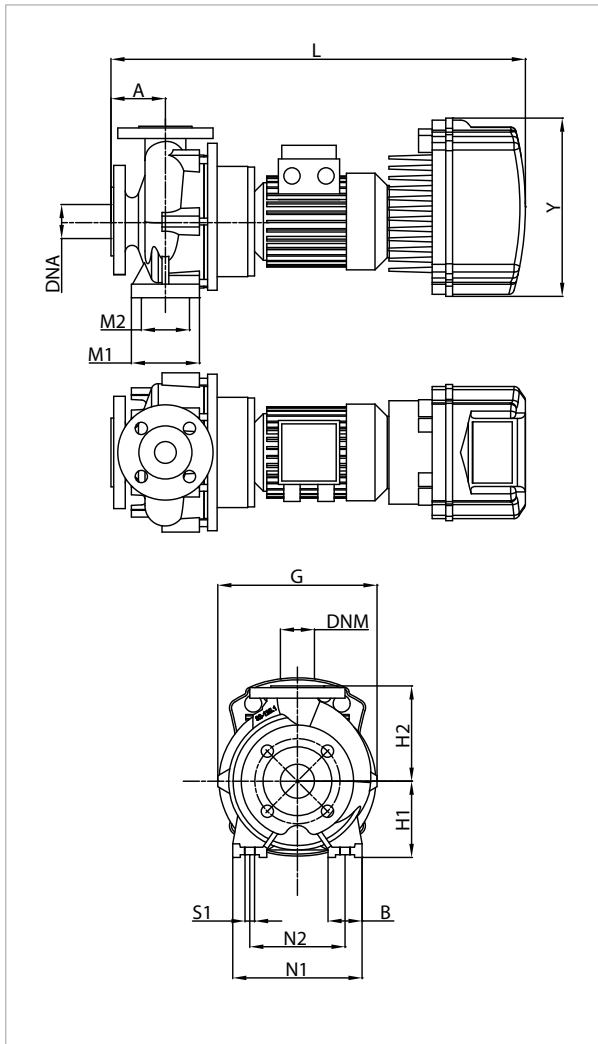

See hydraulic efficiency details on page 241.

The performance curves are based on kinematic viscosity values = 1 mm²/s and density equal to 1000 kg/m³. Curve tolerance according to ISO 9906.

MODEL	MCE MODEL	POWER INPUT 50 Hz	P2 NOMINAL		In A
			kW	HP	
NKM-GE 40-250/245/A/BAQE/2,2 /4 MCE30/P	MCE30/P	1 x 230 ~V	2,2	3,0	6,6

MODEL	A	B	G	H1	H2	L	M1	M2	N1	N2	S1	X	Y	DNA	DNM	PACKING DIMENSIONS			WEIGHT kg
																L/A	L/B	H	
NKM-GE 40-250/245/A/BAQE/2,2 /4 MCE30/P	100	65	336	180	225	799	125	95	320	250	M10	100	353	65	40	826	430	426	89

NKM-GE 40-250 - STANDARDISED MONOBLOC CENTRIFUGAL ELECTRIC PUMPS

WITH INVERTER FOR CIRCULATION OR PRESSURISATION SYSTEMS

MCE-C

MCE-P

Pumped liquid temperature range: from -10 °C to +140 °C (MCE/C) - from -10 °C to +80 °C (MCE/P) - Maximum ambient temperature: +40 °C

≈ 1450 1/min

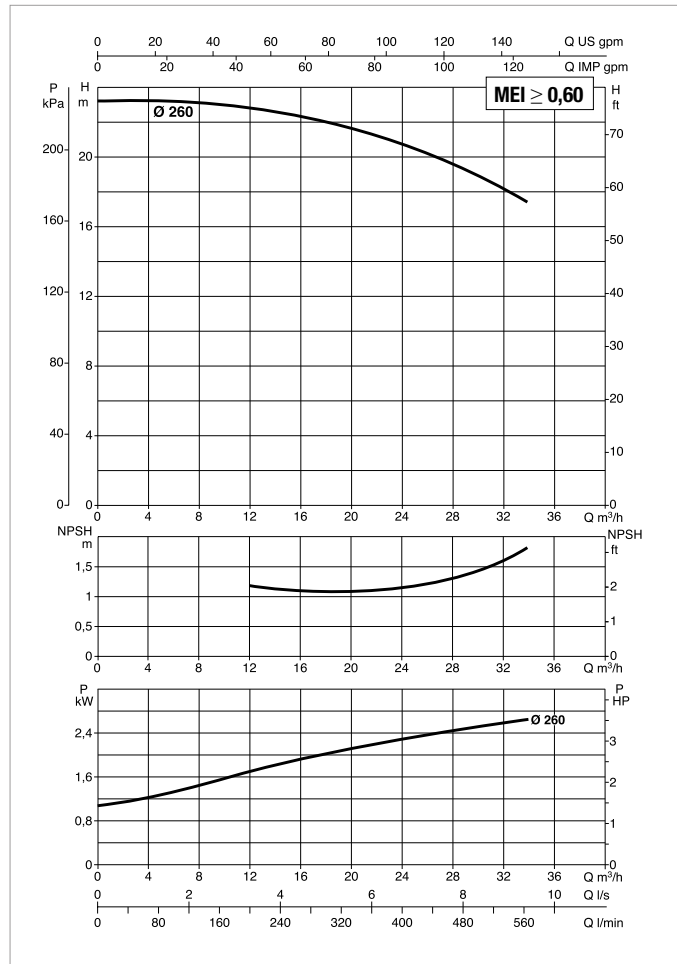
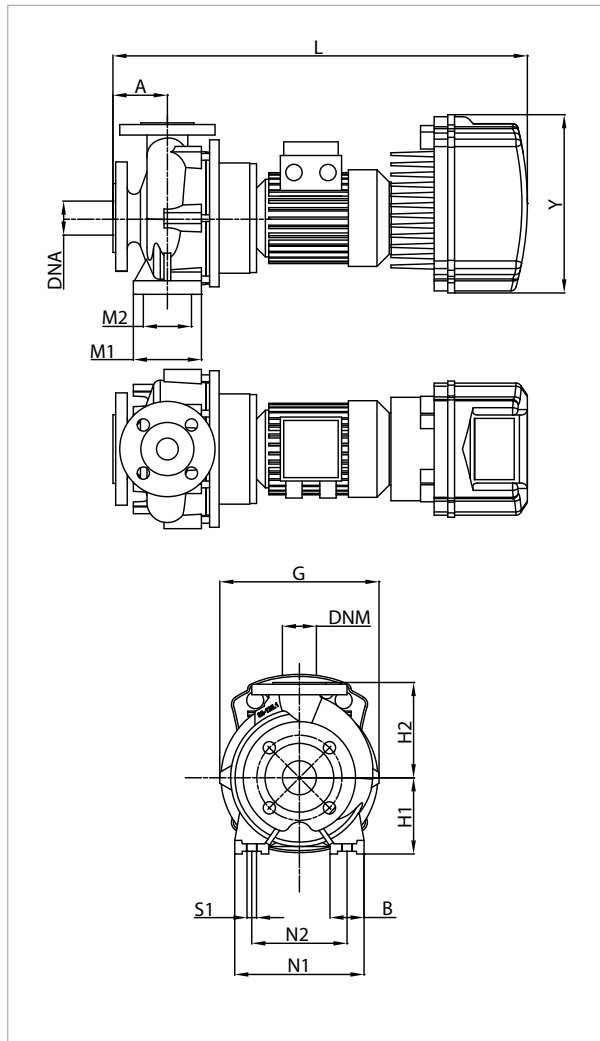

See hydraulic efficiency details on page 241.

The performance curves are based on kinematic viscosity values = 1 mm²/s and density equal to 1000 kg/m³. Curve tolerance according to ISO 9906.

MODEL	MCE MODEL	POWER INPUT 50 Hz	P2 NOMINAL		In A
			kW	HP	
NKM-GE 40-250/260/A/BAQE/3/4 T MCE30/C-P	MCE30/C - MCE30/P	3 x 400 ~V	3,00	4,00	7,2

MODEL	A	B	G	H1	H2	L	M1	M2	N1	N2	S1	X	Y	DNA	DNM	PACKING DIMENSIONS			WEIGHT kg
																L/A	L/B	H	
NKM-GE 40-250/260/A/BAQE/3/4 T MCE30/C-P	100	65	336	180	225	775	125	95	320	250	M10	100	353	65	40	850	500	660	98

NKM-GE 50-125 - STANDARDISED MONOBLOC CENTRIFUGAL ELECTRIC PUMPS WITH INVERTER FOR CIRCULATION SYSTEMS



Pumped liquid temperature range: from -10 °C to +140 °C (MCE/C) - Maximum ambient temperature: +40 °C

≅ 1450 1/min

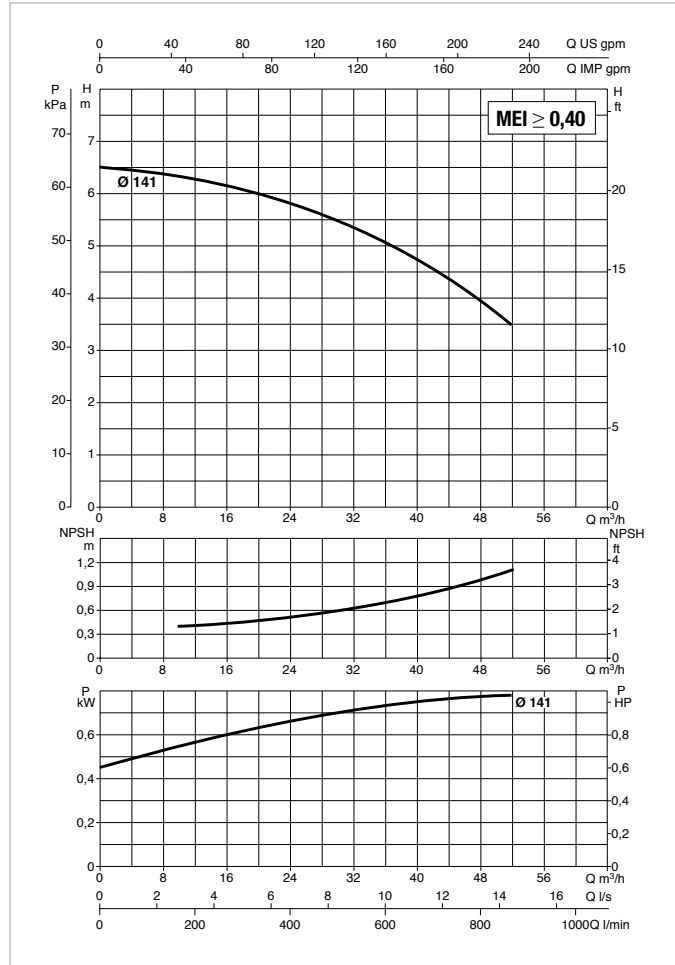
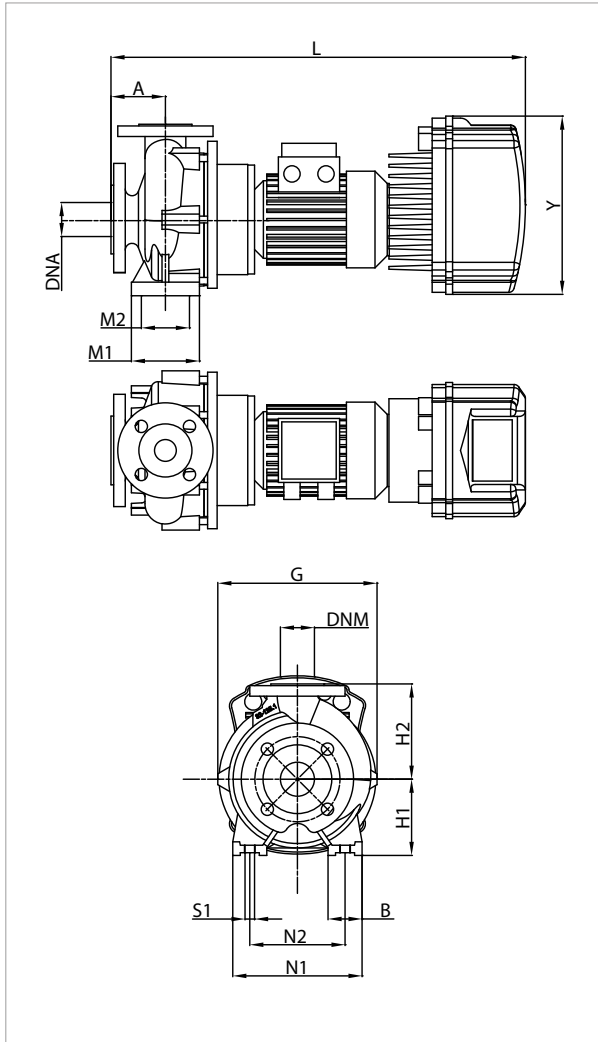

See hydraulic efficiency details on page 241.

The performance curves are based on kinematic viscosity values = 1 mm²/s and density equal to 1000 kg/m³. Curve tolerance according to ISO 9906.

MODEL	MCE MODEL	POWER INPUT 50 Hz	P2 NOMINAL		In A
			kW	HP	
NKM-GE 50-125/141/A/BAQE/0.75/4 M MCE11/C	MCE11/C	1 x 230 ~V	0,75	1,00	9,7
NKM-GE 50-125/141/A/BAQE/0,75/4 T MCE30/C	MCE30/C	3 x 400 ~V	0,75	1,00	t.b.d.

MODEL	A	B	G	H1	H2	L	M1	M2	N1	N2	S1	X	Y	DNA	DNM	PACKING DIMENSIONS			WEIGHT kg
																L/A	L/B	H	
NKM-GE 50-125/141/A/BAQE/0.75/4 M MCE11/C	100	50	250	132	160	680	100	70	240	190	M10	100	262	65	50	850	500	660	55
NKM-GE 50-125/141/A/BAQE/0.75/4 T MCE30/C	100	50	250	132	160	747	100	70	240	190	M10	100	353	65	50	850	500	660	57,6

NKM-GE 50-160 - STANDARDISED MONOBLOC CENTRIFUGAL ELECTRIC PUMPS WITH INVERTER FOR CIRCULATION SYSTEMS



Pumped liquid temperature range: from -10 °C to +140 °C (MCE/C) - Maximum ambient temperature: +40 °C

≈ 1450 1/min

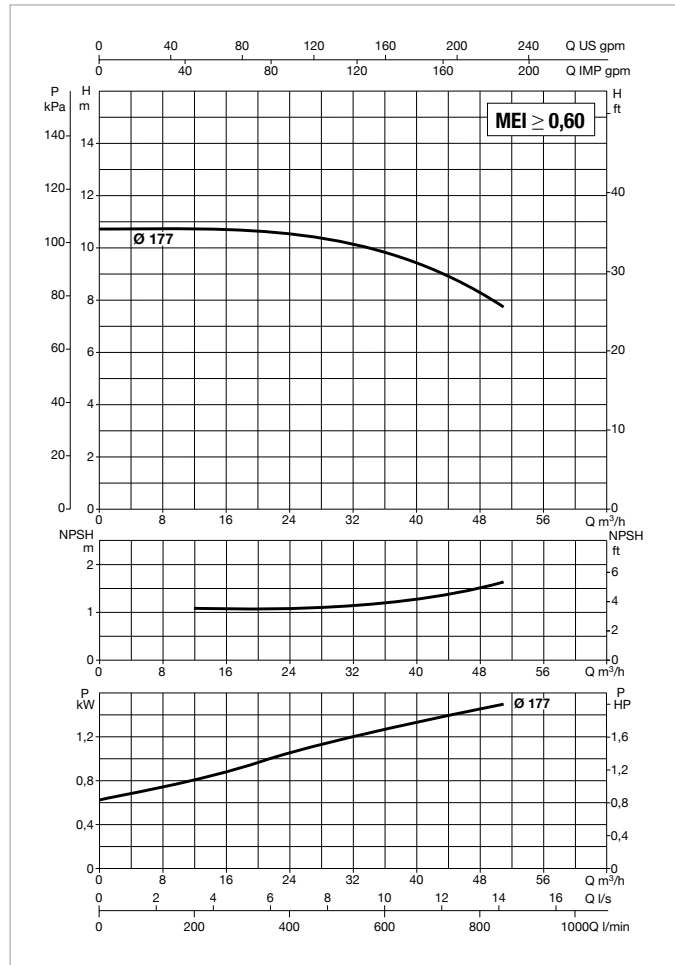
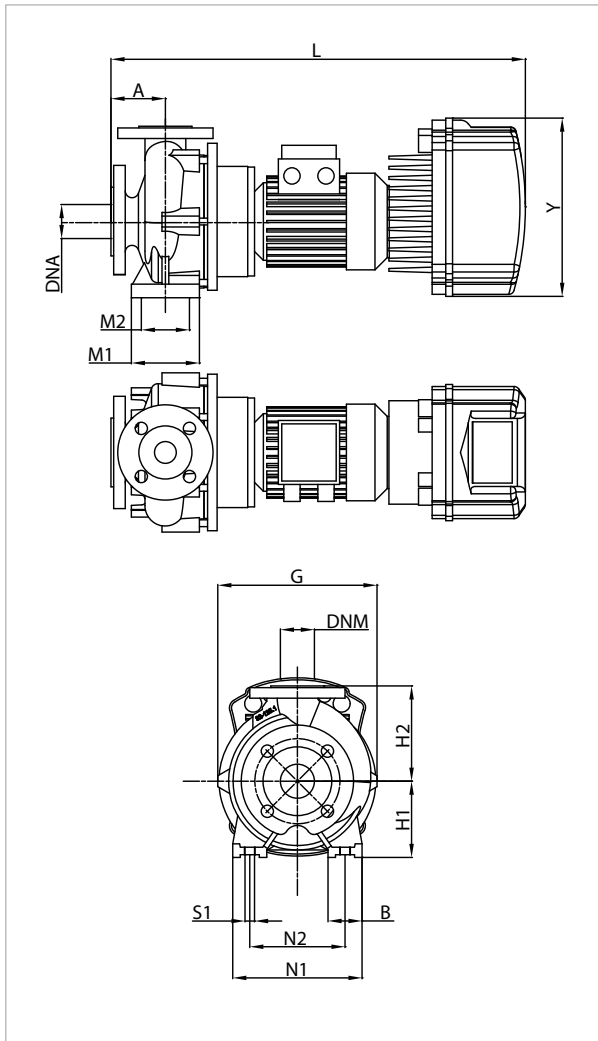

See hydraulic efficiency details on page 241.

The performance curves are based on kinematic viscosity values = 1 mm²/s and density equal to 1000 kg/m³. Curve tolerance according to ISO 9906.

MODEL	MCE MODEL	POWER INPUT 50 Hz	P2 NOMINAL		In A
			kW	HP	
NKM-GE 50-160/177/A/BAQE/1,5/4 M MCE15/C	MCE15/C	1 x 230 ~V	1,50	2,00	13,7
NKM-GE 50-160/177/A/BAQE/1,5/4 T MCE30/C	MCE30/C	3 x 400 ~V	1,50	2,00	4,4

MODEL	A	B	G	H1	H2	L	M1	M2	N1	N2	S1	X	Y	DNA	DNM	PACKING DIMENSIONS			WEIGHT kg
																L/A	L/B	H	
NKM-GE 50-160/177/A/BAQE/1,5/4 M MCE15/C	100	50	282	160	180	746	100	70	265	212	M10	100	262	65	50	850	500	660	64
NKM-GE 50-160/177/A/BAQE/1,5/4 T MCE30/C	100	50	282	160	180	813	100	70	265	212	M10	100	353	65	50	850	500	660	66,7

NKM-GE 50-200 - STANDARDISED MONOBLOC CENTRIFUGAL ELECTRIC PUMPS WITH INVERTER FOR CIRCULATION SYSTEMS



Pumped liquid temperature range: from -10 °C to +140 °C (MCE/C) - Maximum ambient temperature: +40 °C

≅ 1450 1/min

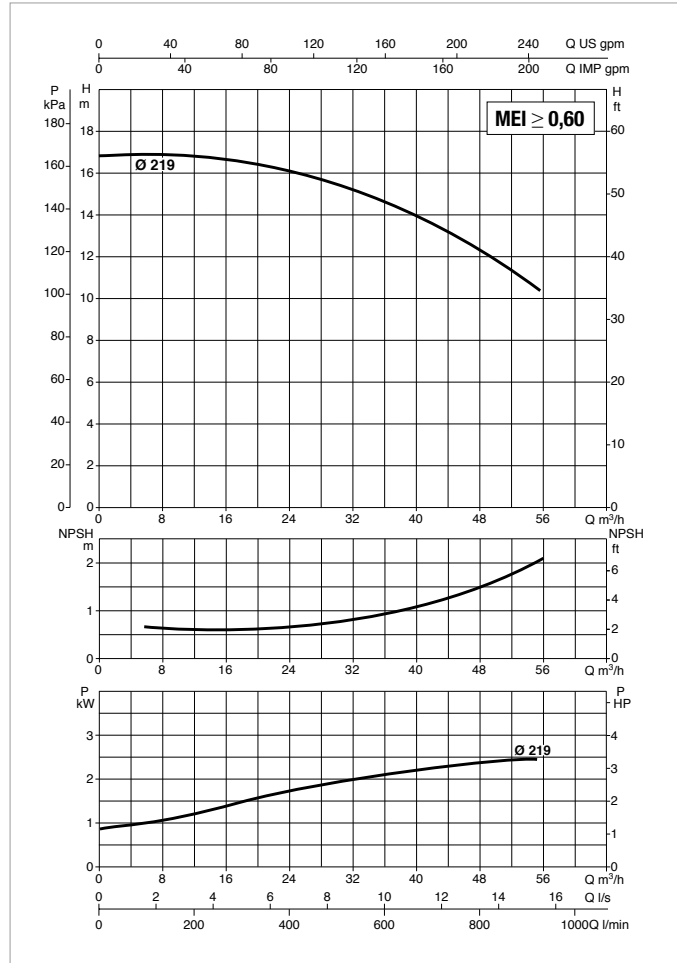
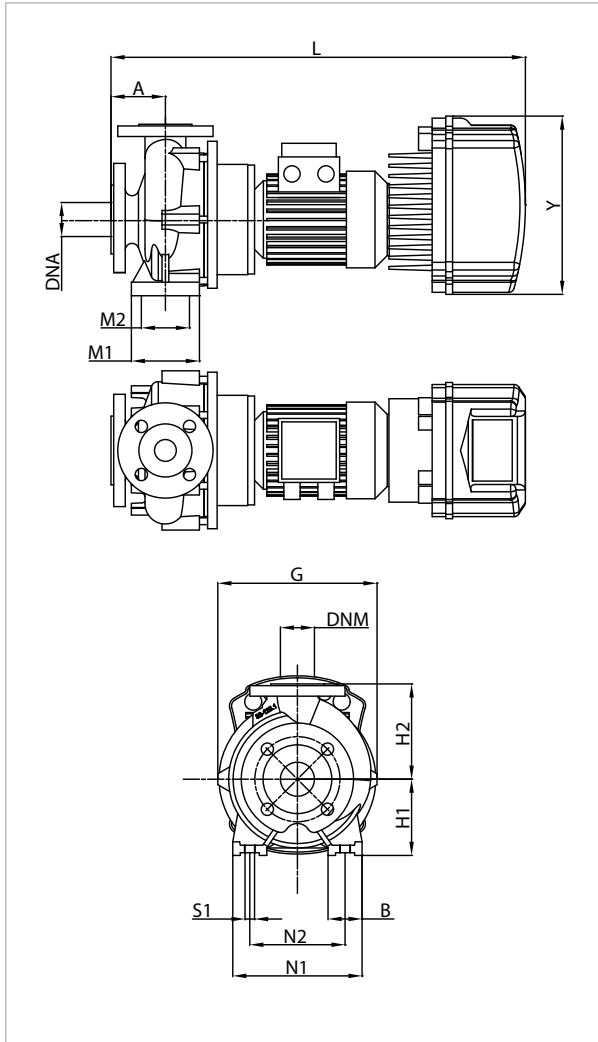

See hydraulic efficiency details on page 241.

The performance curves are based on kinematic viscosity values = 1 mm²/s and density equal to 1000 kg/m³. Curve tolerance according to ISO 9906.

MODEL	MCE MODEL	POWER INPUT 50 Hz	P2 NOMINAL		In A
			kW	HP	
NKM-GE 50-200/219/A/BAQE/3/4 T MCE30/C	MCE30/C	3 x 400 ~V	3,00	4,00	6,7

MODEL	A	B	G	H1	H2	L	M1	M2	N1	N2	S1	X	Y	DNA	DNM	PACKING DIMENSIONS			WEIGHT kg
																L/A	L/B	H	
NKM-GE 50-200/219/A/BAQE/3/4 T MCE30/C	100	50	302	160	200	775	100	70	265	212	M10	100	353	65	50	850	500	660	90

NKM-GE 50-250 - STANDARDISED MONOBLOC CENTRIFUGAL ELECTRIC PUMPS

WITH INVERTER FOR CIRCULATION OR PRESSURISATION SYSTEMS



Pumped liquid temperature range: from -10 °C to +140 °C (MCE/C) - from -10 °C to +80 °C (MCE/P) - Maximum ambient temperature: +40 °C
 ≈ 1450 1/min

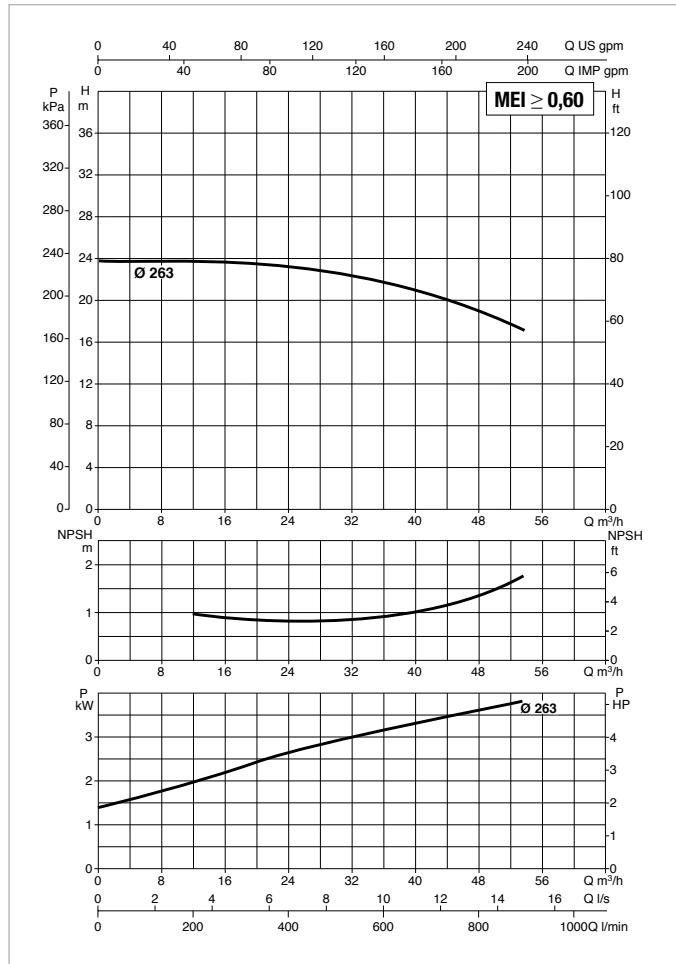
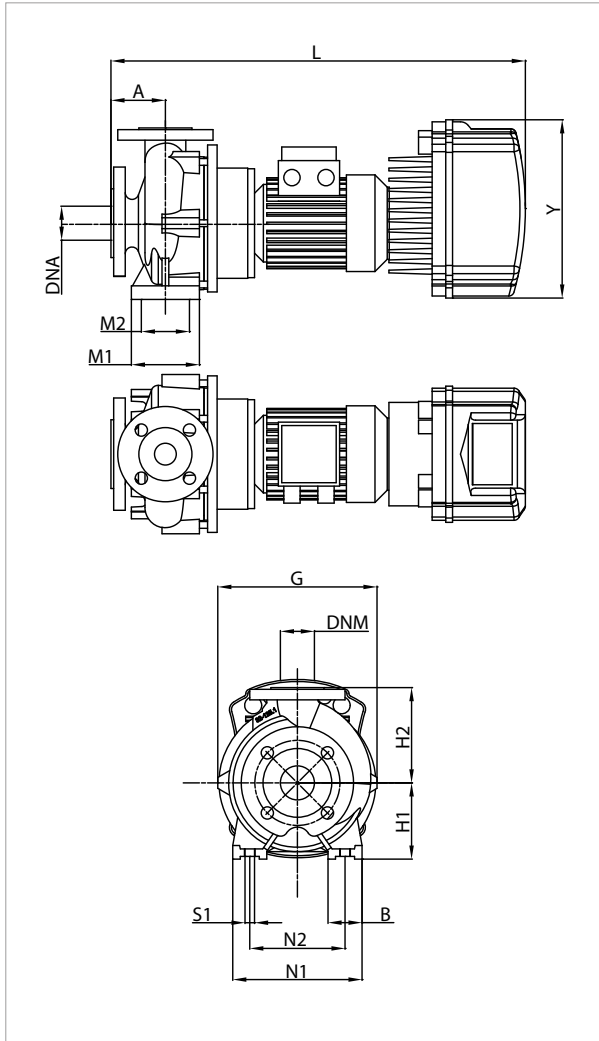

See hydraulic efficiency details on page 241.

The performance curves are based on kinematic viscosity values = 1 mm²/s and density equal to 1000 kg/m³. Curve tolerance according to ISO 9906.

MODEL	MCE MODEL	POWER INPUT 50 Hz	P2 NOMINAL		In A
			kW	HP	
NKM-GE 50-250/263/A/BAQE/4/4 T MCE30/C-P	MCE30/C - MCE30/P	3 x 400 ~V	4,00	5,50	9,4

MODEL	A	B	G	H1	H2	L	M1	M2	N1	N2	S1	X	Y	DNA	DNM	PACKING DIMENSIONS			WEIGHT kg
																L/A	L/B	H	
NKM-GE 50-250/263/A/BAQE/4/4 T MCE30/C-P	100	65	343	180	225	775	125	95	320	250	M10	100	353	65	50	850	500	660	105

NKM-GE 65-125 - STANDARDISED MONOBLOC CENTRIFUGAL ELECTRIC PUMPS WITH INVERTER FOR CIRCULATION SYSTEMS



Pumped liquid temperature range: from -10 °C to +140 °C (MCE/C) - Maximum ambient temperature: +40 °C

≅ 1450 1/min

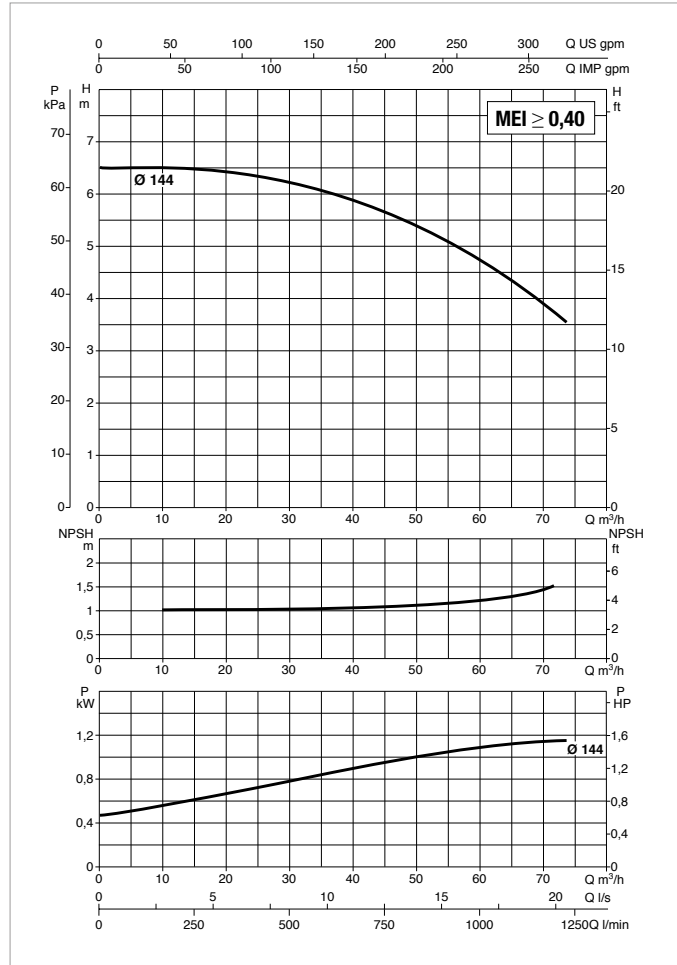
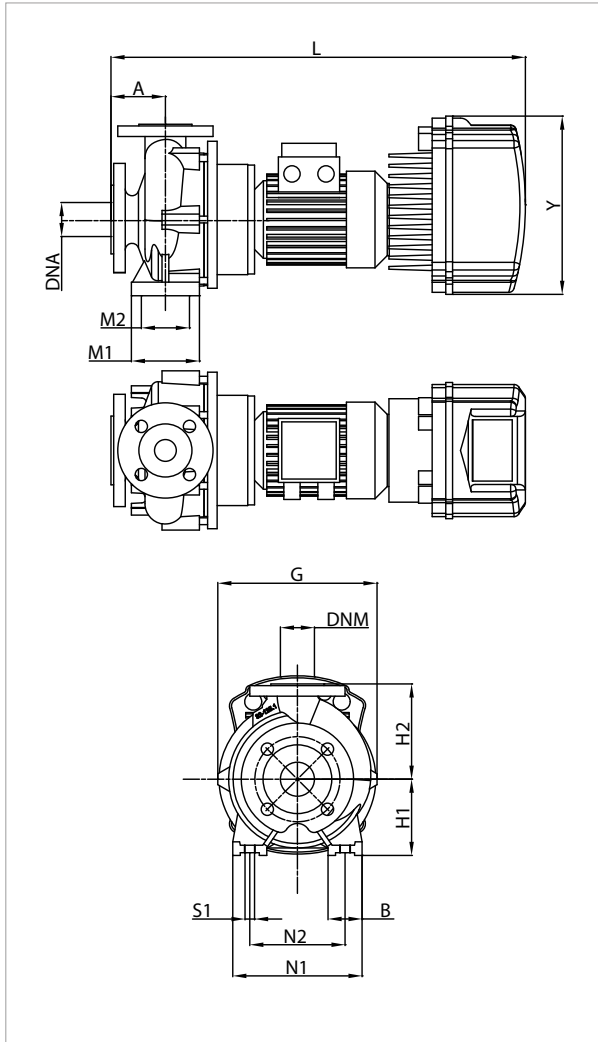

See hydraulic efficiency details on page 241.

The performance curves are based on kinematic viscosity values = 1 mm²/s and density equal to 1000 kg/m³. Curve tolerance according to ISO 9906.

MODEL	MCE MODEL	POWER INPUT 50 Hz	P2 NOMINAL		In A
			kW	HP	
NKM-GE 65-125/144A/BAQE/1.1/4 M MCE11/C	MCE11/C	1 x 230 ~V	1,10	1,50	10,9
NKM-GE 65-125/144A/BAQE/1.1/4 T MCE30/C	MCE30/C	3 x 400 ~V	1,10	1,50	t.b.d.

MODEL	A	B	G	H1	H2	L	M1	M2	N1	N2	S1	X	Y	DNA	DNM	PACKING DIMENSIONS			WEIGHT kg
																L/A	L/B	H	
NKM-GE 65-125/144A/BAQE/1.1/4 M MCE11/C	100	65	286	160	180	693	125	95	280	212	M10	100	262	80	65	850	500	660	65
NKM-GE 65-125/144A/BAQE/1.1/4 T MCE30/C	100	65	286	160	180	760	125	95	280	212	M10	100	353	80	65	850	500	660	67,6

NKM-GE 65-160 - STANDARDISED MONOBLOC CENTRIFUGAL ELECTRIC PUMPS WITH INVERTER FOR CIRCULATION SYSTEMS



Pumped liquid temperature range: from -10 °C to +140 °C (MCE/C) - Maximum ambient temperature: +40 °C

≈ 1450 1/min

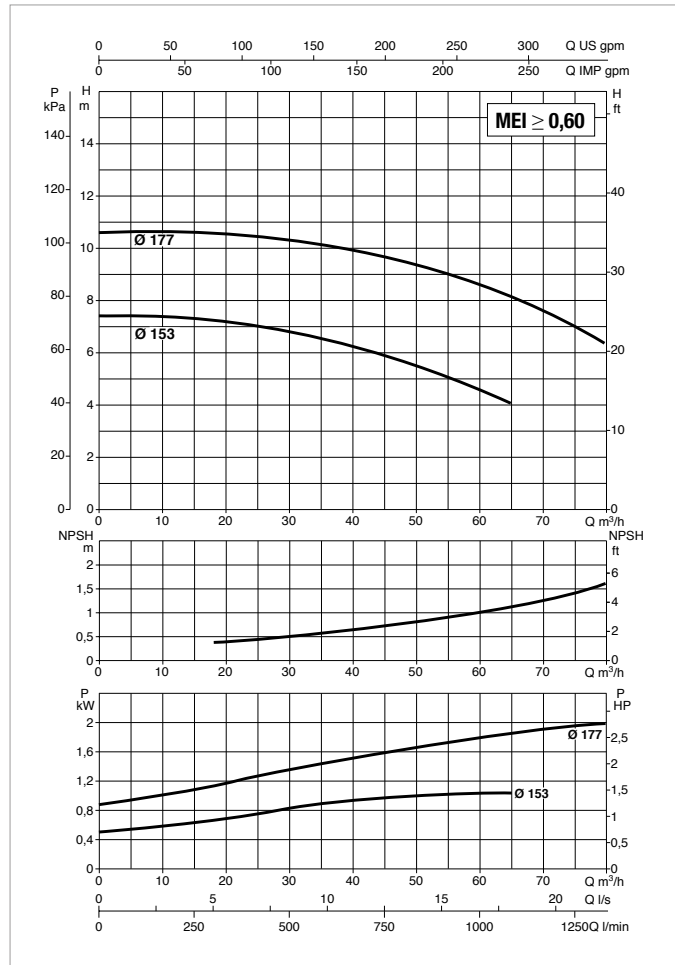
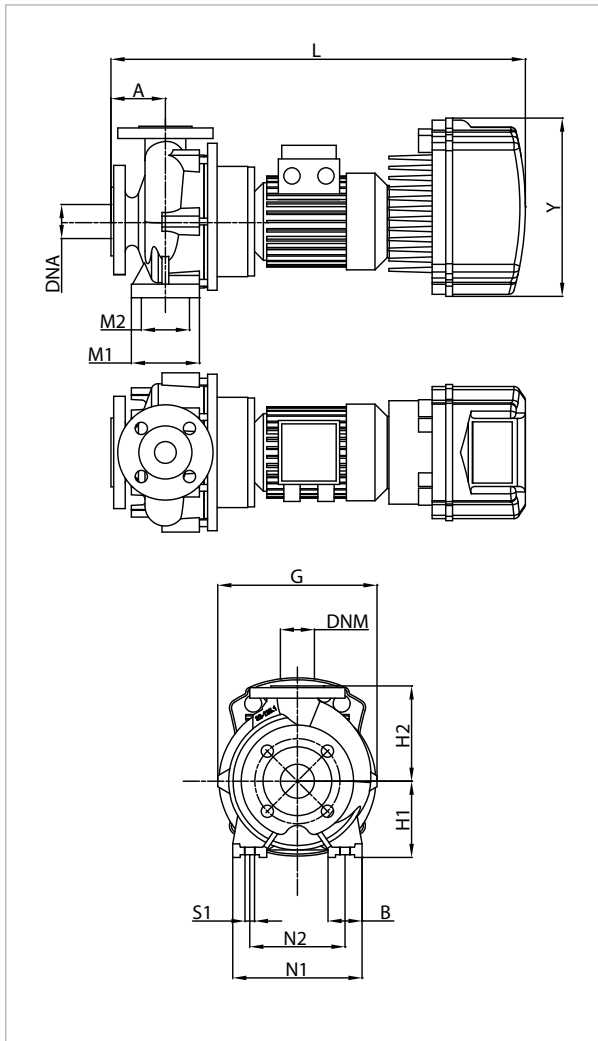

See hydraulic efficiency details on page 241.

The performance curves are based on kinematic viscosity values = 1 mm²/s and density equal to 1000 kg/m³. Curve tolerance according to ISO 9906.

MODEL	MCE MODEL	POWER INPUT 50 Hz	P2 NOMINAL		In A
			kW	HP	
NKM-GE 65-160/153/A/BAQE/1,1/4 M MCE11/C	MCE11/C	1 x 230 ~V	1,10	1,50	11,2
NKM-GE 65-160/153/A/BAQE/1,1/4 T MCE30/C	MCE30/C	3 x 400 ~V	1,10	1,50	3,5
NKM-GE 65-160/177/A/BAQE/2,2/4 M MCE22/C	MCE22/C	1 x 230 ~V	2,20	3,00	17,3
NKM-GE 65-160/177/A/BAQE/2,2/4 T MCE30/C	MCE30/C	3 x 400 ~V	2,20	3,00	5,8

MODEL	A	B	G	H1	H2	L	M1	M2	N1	N2	S1	X	Y	DnA	DnM	PACKING DIMENSIONS			WEIGHT kg
																L/A	L/B	H	
NKM-GE 65-160/153/A/BAQE/1,1/4 M MCE11/C	100	65	302	160	200	693	125	95	280	212	M10	100	262	80	65	850	500	660	67
NKM-GE 65-160/153/A/BAQE/1,1/4 T MCE30/C	100	65	302	160	200	760	125	95	280	212	M10	100	353	80	65	850	500	660	69,6
NKM-GE 65-160/177/A/BAQE/2,2/4 M MCE22/C	100	65	302	160	200	779	125	95	280	212	M10	100	262	80	65	850	500	660	80
NKM-GE 65-160/177/A/BAQE/2,2/4 T MCE30/C	100	65	302	160	200	846	125	95	280	212	M10	100	353	80	65	850	500	660	82,6

NKM-GE 65-200 - STANDARDISED MONOBLOC CENTRIFUGAL ELECTRIC PUMPS WITH INVERTER FOR CIRCULATION SYSTEMS



Pumped liquid temperature range: from -10 °C to +140 °C (MCE/C) - Maximum ambient temperature: +40 °C

≅ 1450 1/min

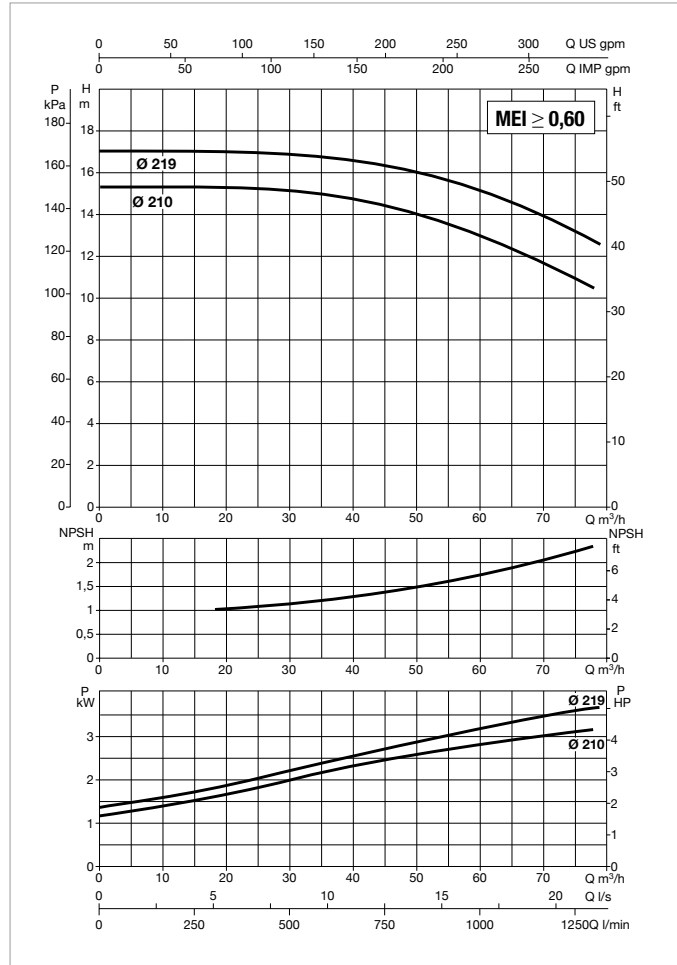
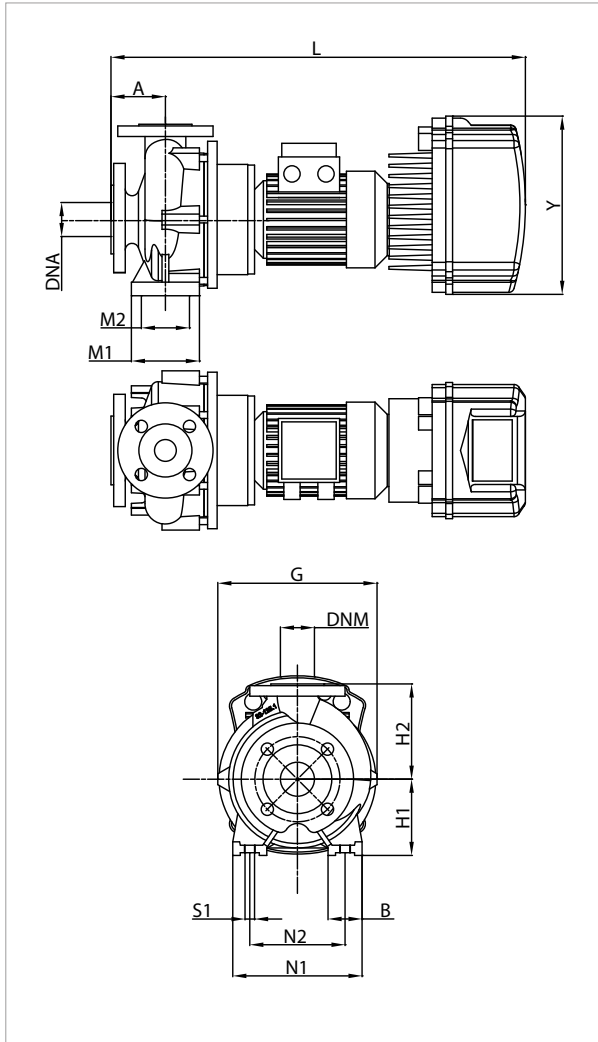

See hydraulic efficiency details on page 241.

The performance curves are based on kinematic viscosity values = 1 mm²/s and density equal to 1000 kg/m³. Curve tolerance according to ISO 9906.

MODEL	MCE MODEL	POWER INPUT 50 Hz	P2 NOMINAL		In A
			kW	HP	
NKM-GE 65-200/210/A/BAQE/3/4 T MCE30/C	MCE30/C	3 x 400 ~V	3,00	4,00	7,8
NKM-GE 65-200/219/A/BAQE/4/4 T MCE30/C	MCE30/C	3 x 400 ~V	4,00	5,50	8,8

MODEL	A	B	G	H1	H2	L	M1	M2	N1	N2	S1	X	Y	DNA	DNM	PACKING DIMENSIONS			WEIGHT kg
																L/A	L/B	H	
NKM-GE 65-200/210/A/BAQE/3/4 T MCE30/C	100	65	333	180	225	779	125	95	320	250	M10	140	353	80	65	850	500	660	97
NKM-GE 65-200/219/A/BAQE/4/4 T MCE30/C	100	65	333	180	225	802	125	95	320	250	M10	140	353	80	65	850	500	660	105

NKM-GE 65-250 - STANDARDISED MONOBLOC CENTRIFUGAL ELECTRIC PUMPS

WITH INVERTER FOR CIRCULATION OR PRESSURISATION SYSTEMS



Pumped liquid temperature range: from -10 °C to +140 °C (MCE/C) - from -10 °C to +80 °C (MCE/P) - Maximum ambient temperature: +40 °C

≈ 1450 1/min

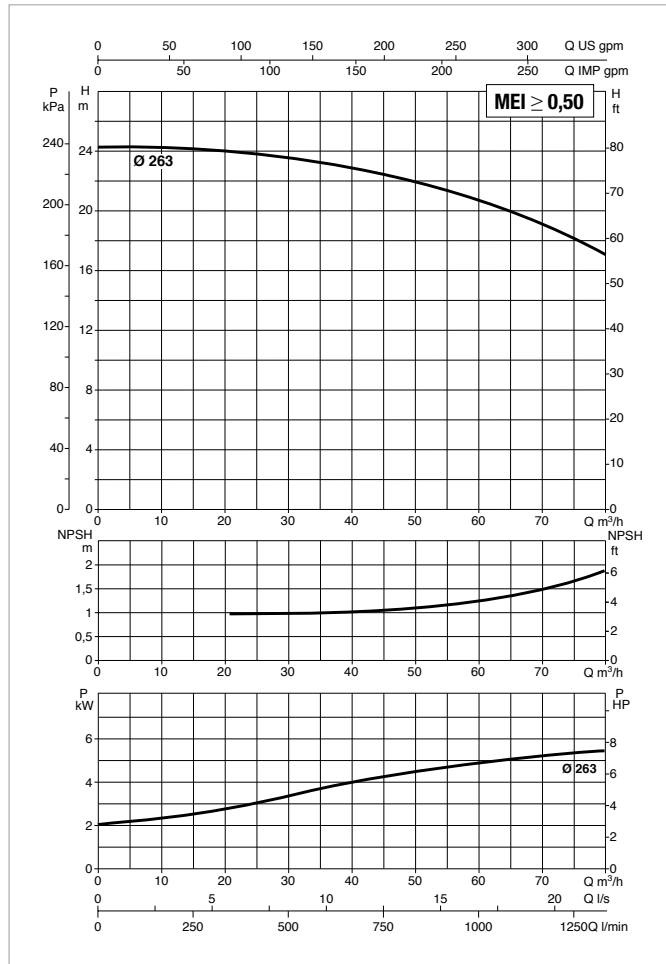
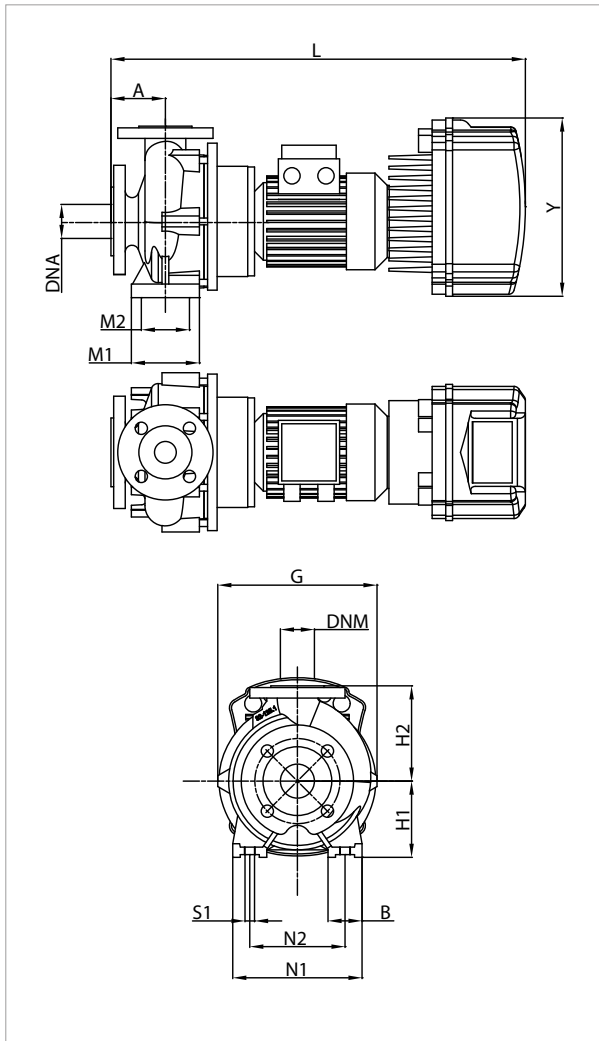

See hydraulic efficiency details on page 241.

The performance curves are based on kinematic viscosity values = 1 mm²/s and density equal to 1000 kg/m³. Curve tolerance according to ISO 9906.

MODEL	MCE MODEL	POWER INPUT 50 Hz	P2 NOMINAL		In A
			kW	HP	
NKM-GE 65-250/263/A/BAQE/5,5/4 T MCE55/C-P	MCE55/C - MCE55/P	3 x 400 ~V	5,50	7,50	12,7

MODEL	A	B	G	H1	H2	L	M1	M2	N1	N2	S1	X	Y	DNA	DNM	PACKING DIMENSIONS			WEIGHT kg
																L/A	L/B	H	
NKM-GE 65-250/263/A/BAQE/5,5/4 T MCE55/C-P	100	80	370	200	250	913	160	120	360	280	M14	140	353	80	65	1100	550	620	168

NKM-GE 65-315 - STANDARDISED MONOBLOC CENTRIFUGAL ELECTRIC PUMPS WITH INVERTER FOR PRESSURISATION SYSTEMS



Pumped liquid temperature range: from -10 °C to +80 °C (MCE/P) - Maximum ambient temperature: +40 °C

≅ 1450 1/min

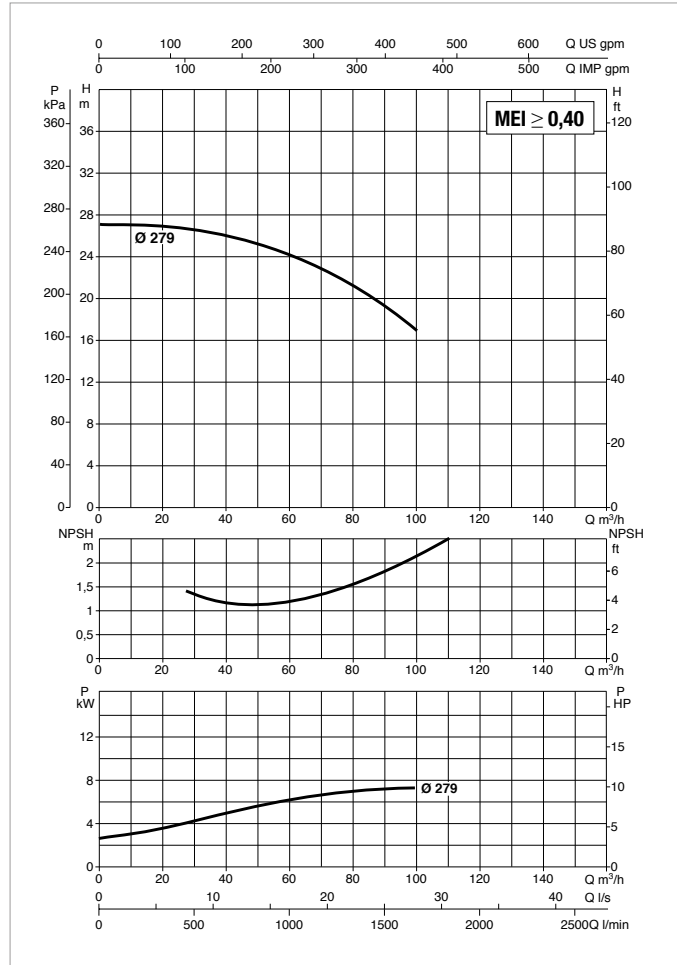
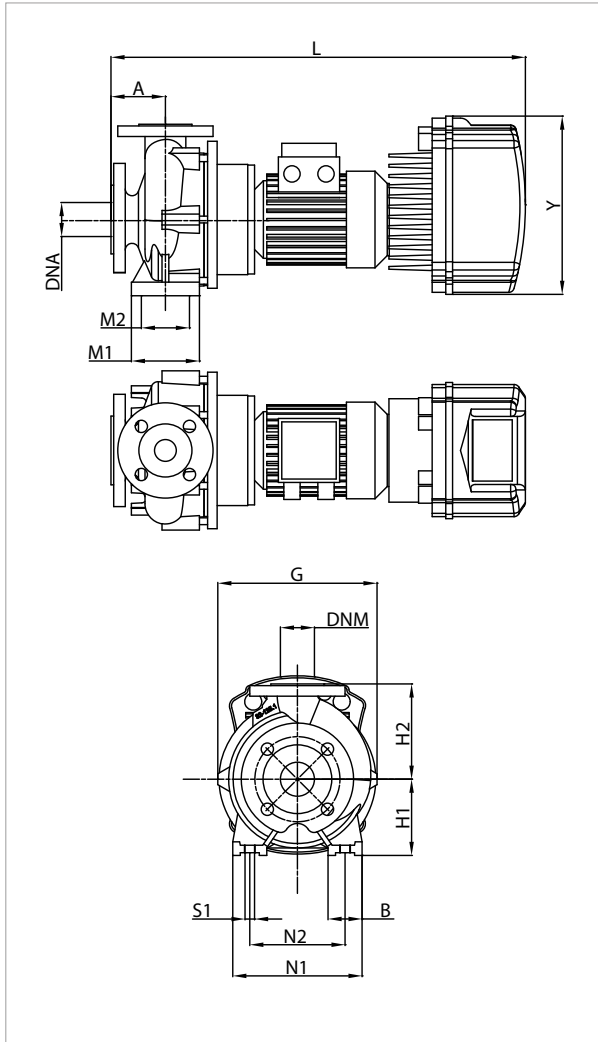

See hydraulic efficiency details on page 241.

The performance curves are based on kinematic viscosity values = 1 mm²/s and density equal to 1000 kg/m³. Curve tolerance according to ISO 9906.

MODEL	MCE MODEL	POWER INPUT 50 Hz	P2 NOMINAL		In A
			kW	HP	
NKM-GE 65-315/279/A/BAQE/7,5/4MCE110/P	MCE110/P	3 x 400 ~V	7,5	10,0	17,9

MODEL	A	B	G	H1	H2	L	M1	M2	N1	N2	S1	X	Y	DNA	DNM	PACKING DIMENSIONS			WEIGHT kg
																L/A	L/B	H	
NKM-GE 65-315/279/A/BAQE/7,5/4MCE110/P	125	80	429	225	280	1048	160	120	400	315	M14	140	426	80	65	1386	526	676	195

NKM-GE 65-315 - STANDARDISED MONOBLOC CENTRIFUGAL ELECTRIC PUMPS WITH INVERTER FOR CIRCULATION SYSTEMS



Pumped liquid temperature range: from -10 °C to +140 °C (MCE/C) - Maximum ambient temperature: +40 °C

≈ 1450 1/min

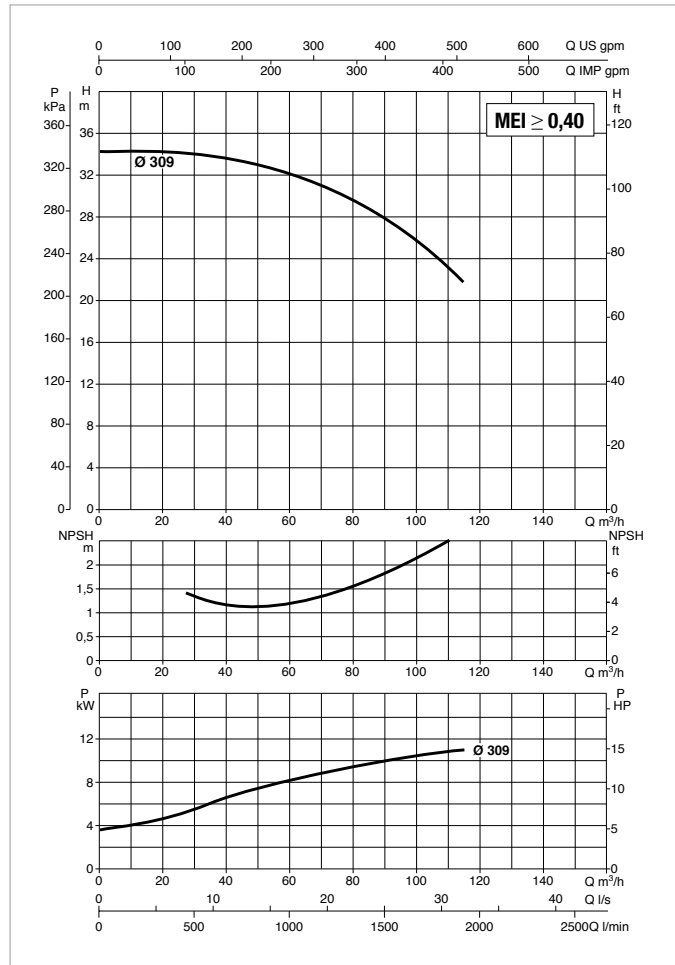
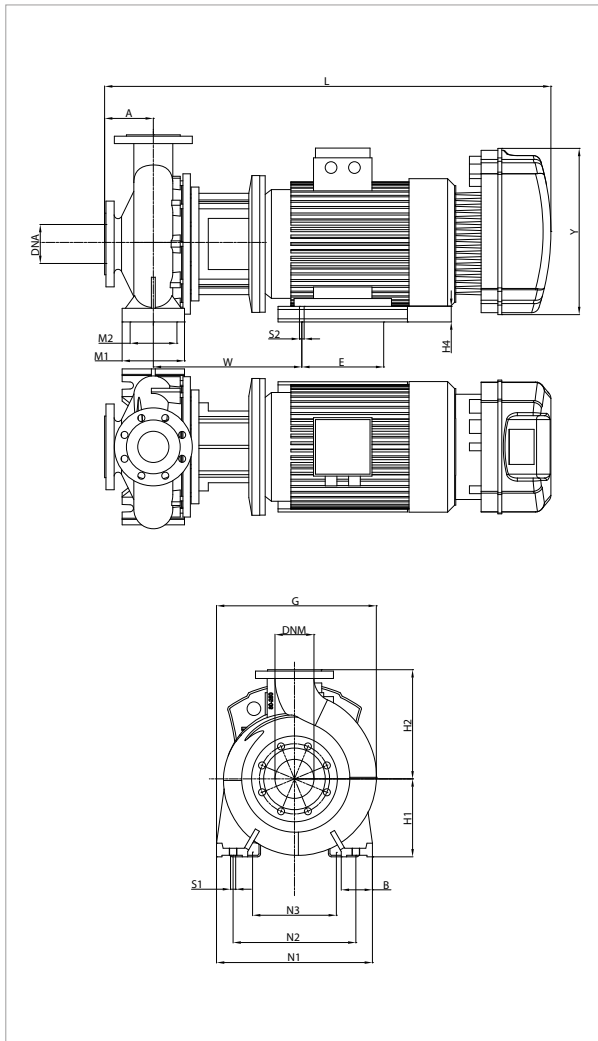

See hydraulic efficiency details on page 241.

The performance curves are based on kinematic viscosity values = 1 mm²/s and density equal to 1000 kg/m³. Curve tolerance according to ISO 9906.

MODEL	MCE MODEL	POWER INPUT 50 Hz	P2 NOMINAL		In A
			kW	HP	
NKM-GE 65-315/309/A/BAQE/11/4 T MCE110/C	MCE110/C	3 x 400 ~V	11,00	15,00	26,6

MODEL	A	B	E	G	H1	H2	H4	L	M1	M2	N1	N2	S1	S2	W	X	Y	DNA	DNM	PACKING DIMENSIONS			WEIGHT kg
																				L/A	L/B	H	
NKM-GE 65-315/309/A/BAQE/11/4 T MCE110/C	125	80	210	429	225	280	65	1108	160	120	400	315	M14	M12	402	140	426	80	65	1250	560	575	263

NKM-GE 65-315 - STANDARDISED MONOBLOC CENTRIFUGAL ELECTRIC PUMPS WITH INVERTER FOR PRESSURISATION SYSTEMS



Pumped liquid temperature range: from -10 °C to +80 °C (MCE/P) - Maximum ambient temperature: +40 °C

≅ 1450 1/min

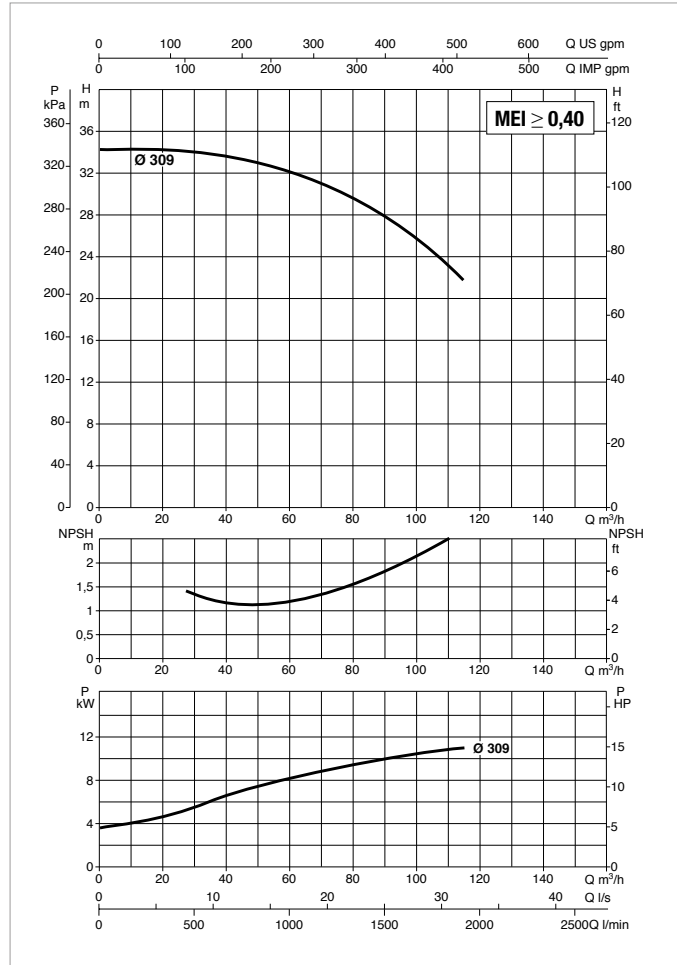
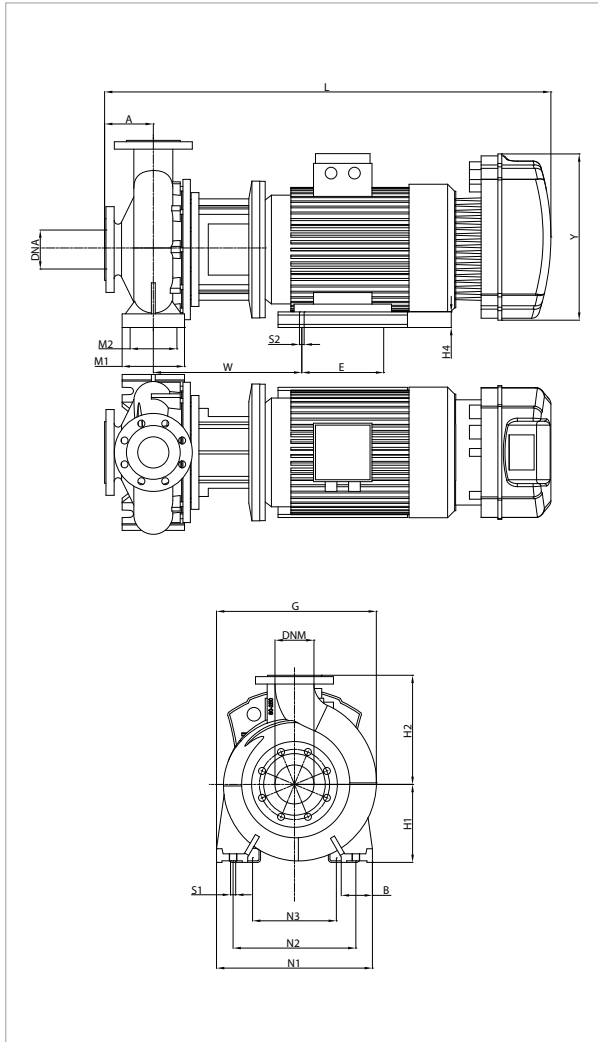

See hydraulic efficiency details on page 241.

The performance curves are based on kinematic viscosity values = 1 mm²/s and density equal to 1000 kg/m³. Curve tolerance according to ISO 9906.

MODEL	MCE MODEL	POWER INPUT 50 Hz	P2 NOMINAL		In A
			kW	HP	
NKM-GE65-315/309/A/BAQE/11/4 MCE150/P	MCE150/P	3 x 400 -V	11,00	15,00	27,2

MODEL	A	B	E	G	H1	H2	H4	L	M1	M2	N1	N2	S1	S2	W	X	Y	DNA	DNM	PACKING DIMENSIONS			WEIGHT kg
																				L/A	L/B	H	
NKM-GE65-315/309/A/BAQE/11/4 MCE150/P	125	80	210	429	225	280	65	1108	160	120	400	315	M14	M12	402	140	426	80	65	1250	560	575	263

NKM-GE 80-160 - STANDARDISED MONOBLOC CENTRIFUGAL ELECTRIC PUMPS WITH INVERTER FOR CIRCULATION SYSTEMS



Pumped liquid temperature range: from -10 °C to +140 °C (MCE/C) - Maximum ambient temperature: +40 °C

≅ 1450 1/min

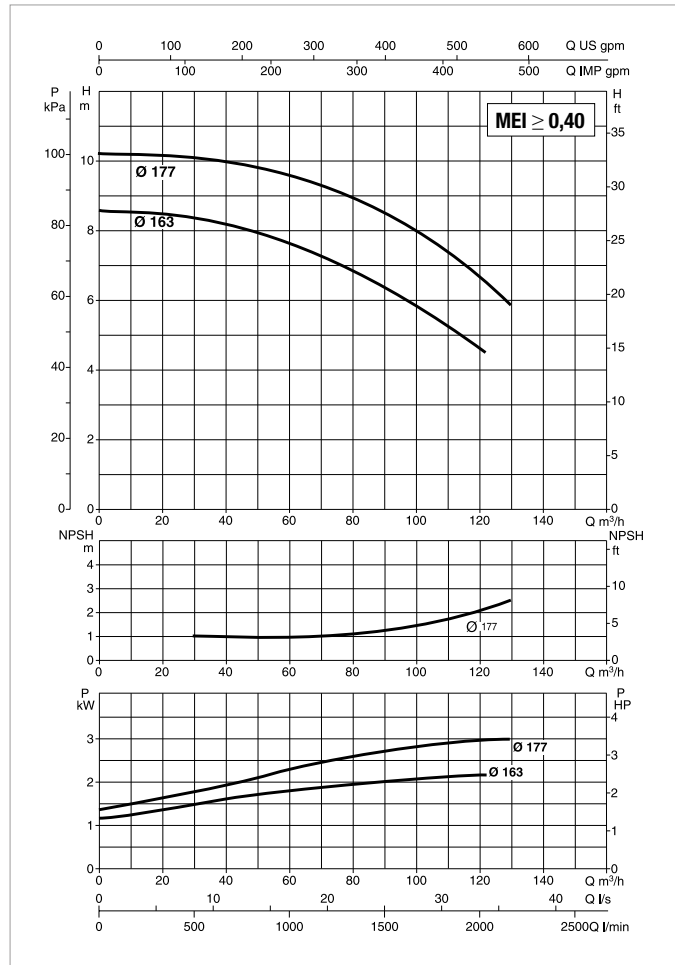
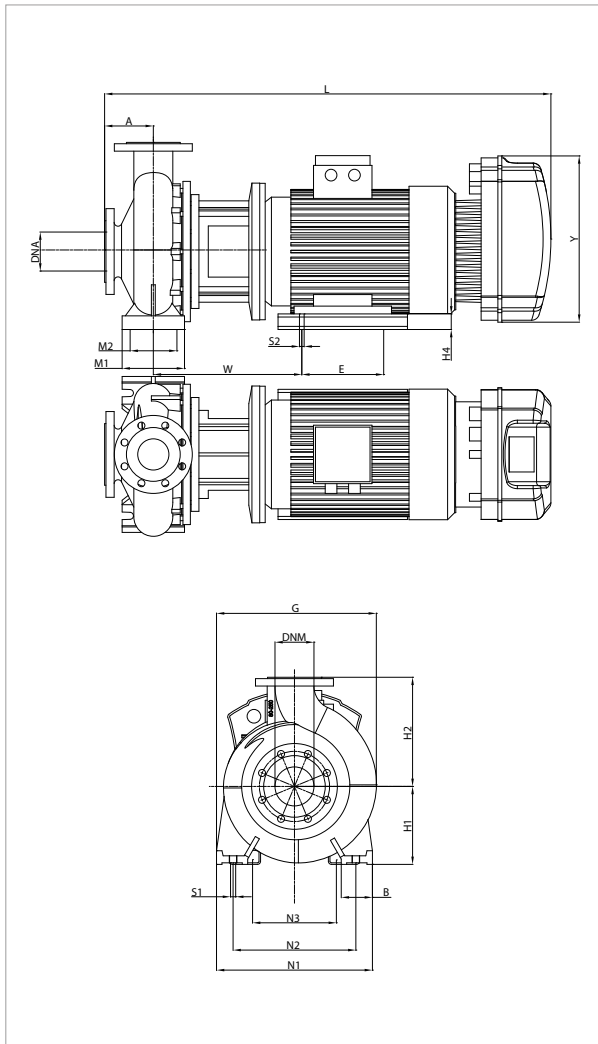

See hydraulic efficiency details on page 241.

The performance curves are based on kinematic viscosity values = 1 mm²/s and density equal to 1000 kg/m³. Curve tolerance according to ISO 9906.

MODEL	MCE MODEL	POWER INPUT 50 Hz	P2 NOMINAL		In A
			kW	HP	
NKM-GE 80-160/163/A/BAQE/2,2/4 M MCE22/C	MCE22/C	1 x 230 ~V	2,20	3,00	19,6
NKM-GE 80-160/163/A/BAQE/2,2/4 T MCE30/C	MCE30/C	3 x 400 ~V	2,20	3,00	t.b.d.
NKM-GE 80-160/177/A/BAQE/3/4 T MCE30/C	MCE30/C	3 x 400 ~V	3,00	4,00	7,6

MODEL	A	B	G	H1	H2	L	M1	M2	N1	N2	S1	X	Y	DNA	DNM	PACKING DIMENSIONS			WEIGHT kg
																L/A	L/B	H	
NKM-GE 80-160/163/A/BAQE/2,2/4 M MCE22/C	125	65	342	180	225	804	125	95	320	250	M10	140	262	100	80	850	500	660	87
NKM-GE 80-160/163/A/BAQE/2,2/4 T MCE30/C	125	65	342	180	225	871	125	95	320	250	M10	140	353	100	80	850	500	660	89,6
NKM-GE 80-160/177/A/BAQE/3/4 T MCE30/C	125	65	342	180	225	804	125	95	320	250	M10	140	353	100	80	850	500	660	96

NKM-GE 80-200 - STANDARDISED MONOBLOC CENTRIFUGAL ELECTRIC PUMPS WITH INVERTER FOR CIRCULATION SYSTEMS



Pumped liquid temperature range: from -10 °C to +140 °C (MCE/C) - Maximum ambient temperature: +40 °C

≅ 1450 1/min

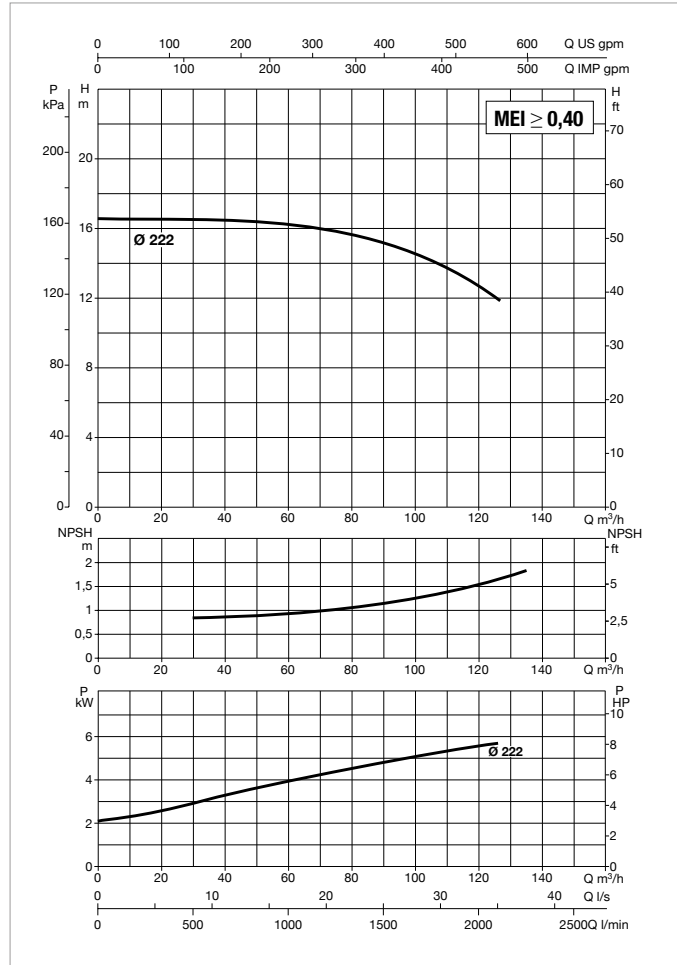
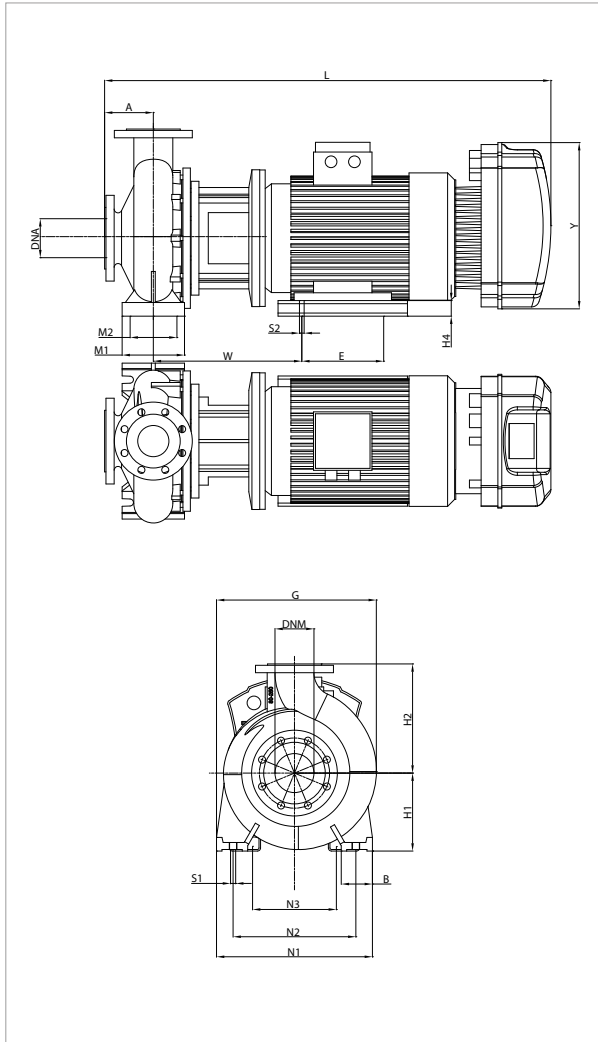

See hydraulic efficiency details on page 241.

The performance curves are based on kinematic viscosity values = 1 mm²/s and density equal to 1000 kg/m³. Curve tolerance according to ISO 9906.

MODEL	MCE MODEL	POWER INPUT 50 Hz	P2 NOMINAL		In A
			kW	HP	
NKM-GE 80-200/222/A/BAQE/5.5/4 T MCE55/C	MCE55/C	3 x 400 ~V	5,50	7,50	12,9

MODEL	A	B	G	H1	H2	L	M1	M2	N1	N2	S1	X	Y	DNA	DNM	PACKING DIMENSIONS			WEIGHT kg
																L/A	L/B	H	
NKM-GE 80-200/222/A/BAQE/5.5/4 T MCE55/C	125	65	365	180	250	938	125	95	345	280	M10	140	353	100	80	1100	550	620	156

NKM-GE 80-250 - STANDARDISED MONOBLOC CENTRIFUGAL ELECTRIC PUMPS WITH INVERTER FOR PRESSURISATION SYSTEMS



Pumped liquid temperature range: from -10 °C to +80 °C (MCE/P) - Maximum ambient temperature: +40 °C

≈ 1450 1/min

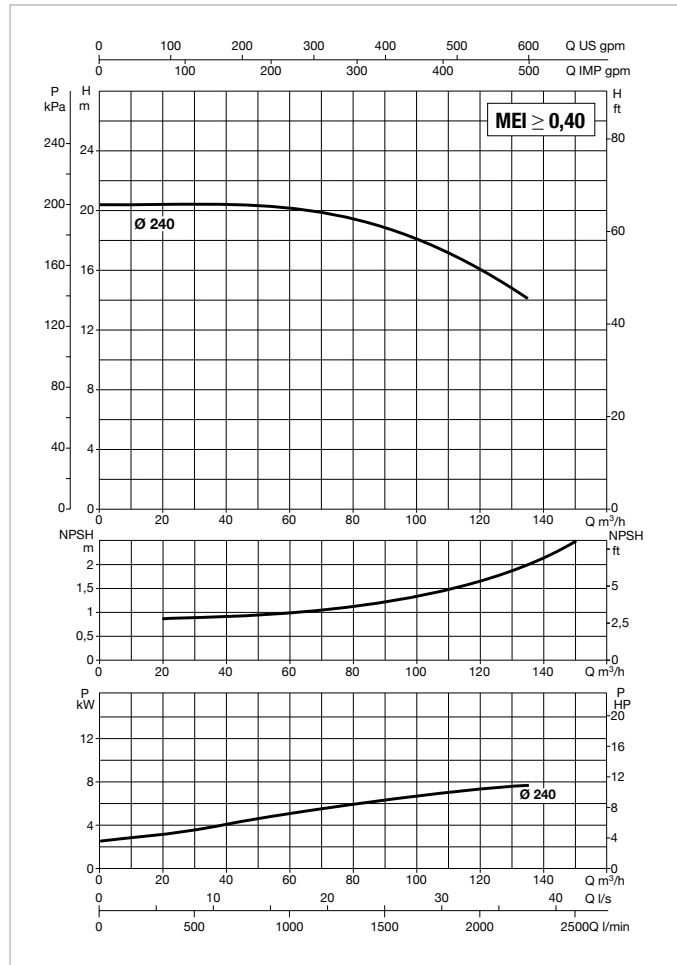
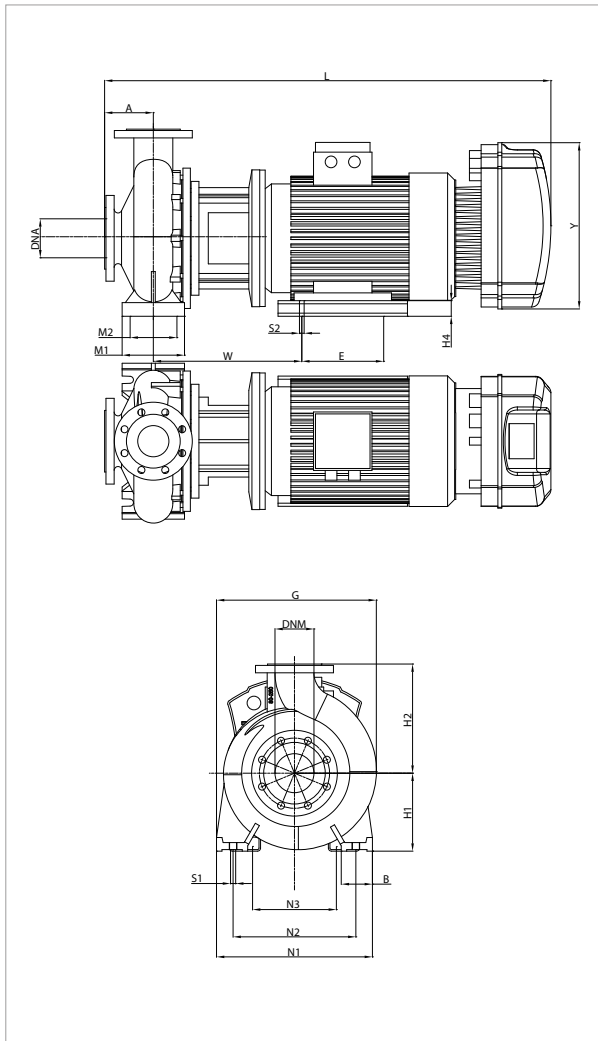

See hydraulic efficiency details on page 241.

The performance curves are based on kinematic viscosity values = 1 mm²/s and density equal to 1000 kg/m³. Curve tolerance according to ISO 9906.

MODEL	MCE MODEL	POWER INPUT 50 Hz	P2 NOMINAL		In A
			kW	HP	
NKM-GE 80-250/240/A/BAQE/7,5/4MCE110/P	MCE110/P	3 x 400 ~V	7,5	10,0	17,9

MODEL	A	B	G	H1	H2	L	M1	M2	N1	N2	S1	X	Y	DNA	DNM	PACKING DIMENSIONS			WEIGHT kg
																L/A	L/B	H	
NKM-GE 80-250/240/A/BAQE/7,5/4MCE110/P	125	80	410	200	280	1048	160	120	400	315	M14	140	426	100	80	1386	526	676	185

NKM-GE 80-250 - STANDARDISED MONOBLOC CENTRIFUGAL ELECTRIC PUMPS WITH INVERTER FOR CIRCULATION SYSTEMS



Pumped liquid temperature range: from -10 °C to +140 °C (MCE/C) - Maximum ambient temperature: +40 °C

≅ 1450 1/min

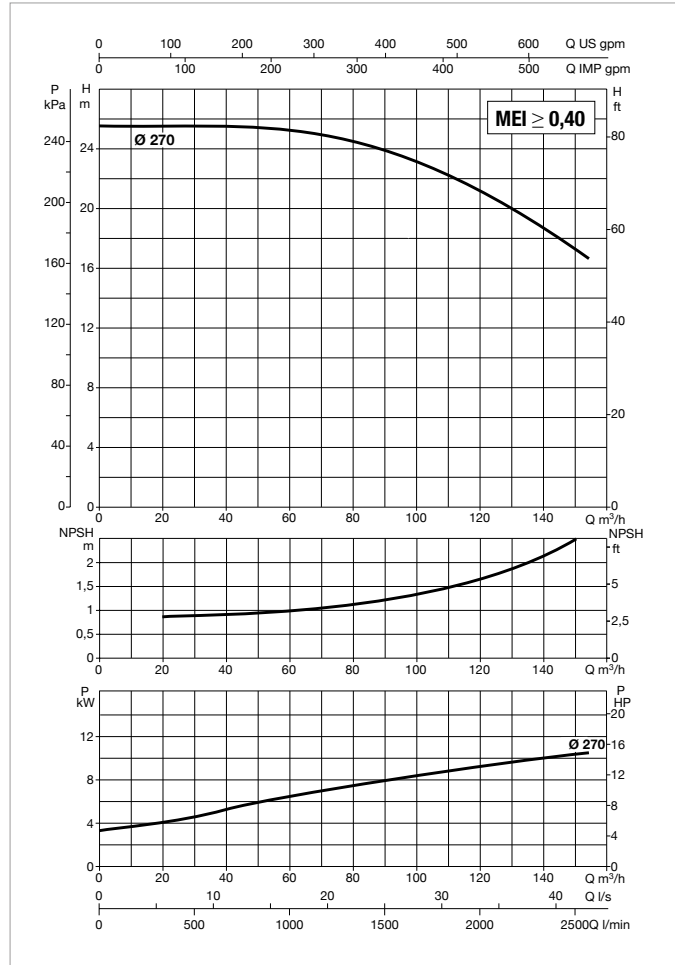
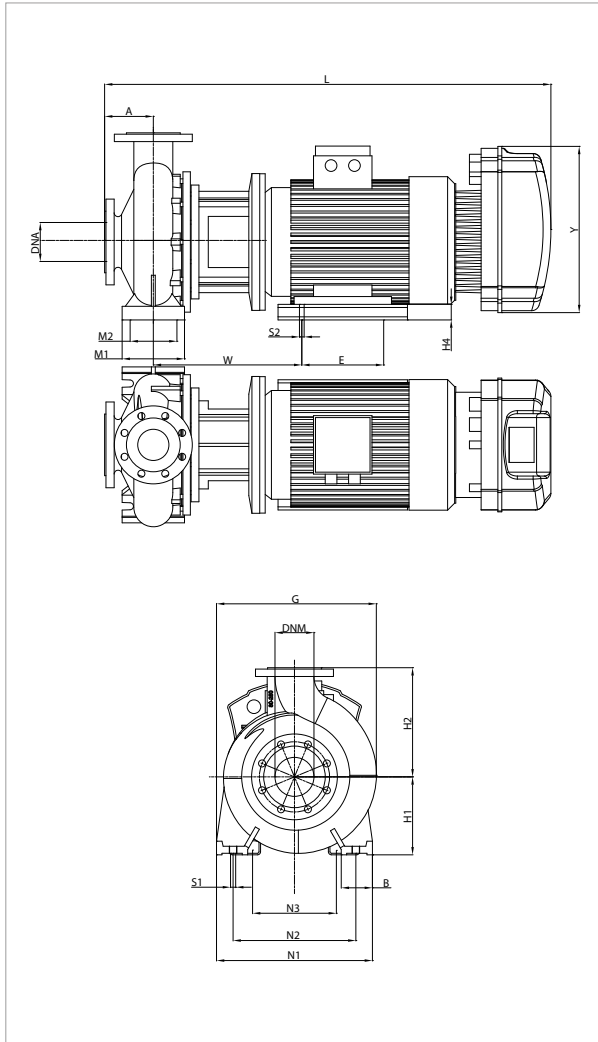

See hydraulic efficiency details on page 241.

The performance curves are based on kinematic viscosity values = 1 mm²/s and density equal to 1000 kg/m³. Curve tolerance according to ISO 9906.

MODEL	MCE MODEL	POWER INPUT 50 Hz	P2 NOMINAL		In A
			kW	HP	
NKM-GE 80-250/270/A/BAQE/11/4 T MCE110/C	MCE110/C	3 x 400 ~V	11,00	15,00	24,4

MODEL	A	B	E	G	H1	H2	H4	L	M1	M2	N1	N2	S1	S2	W	X	Y	DNA	DNM	PACKING DIMENSIONS			WEIGHT kg
																				L/A	L/B	H	
NKM-GE 80-250/270/A/BAQE/11/4 T MCE110/C	125	80	210	410	200	280	40	1108	160	120	400	315	M14	M12	381	140	426	100	80	1250	560	575	237

NKM-GE 80-250 - STANDARDISED MONOBLOC CENTRIFUGAL ELECTRIC PUMPS WITH INVERTER FOR PRESSURISATION SYSTEMS



Pumped liquid temperature range: from -10 °C to +80 °C (MCE/P) - Maximum ambient temperature: +40 °C

≈ 1450 1/min

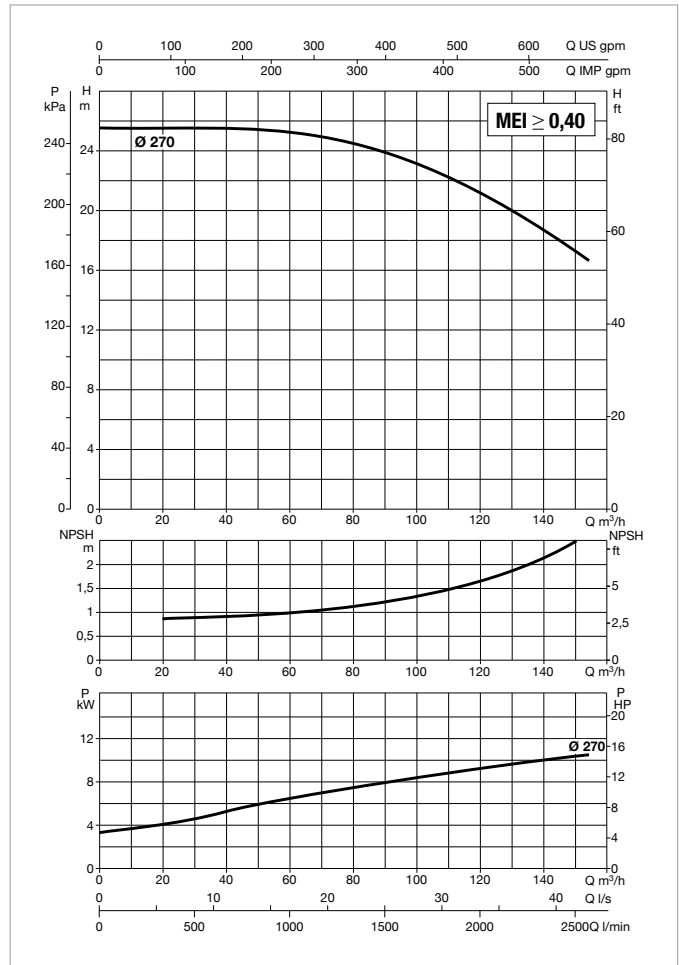
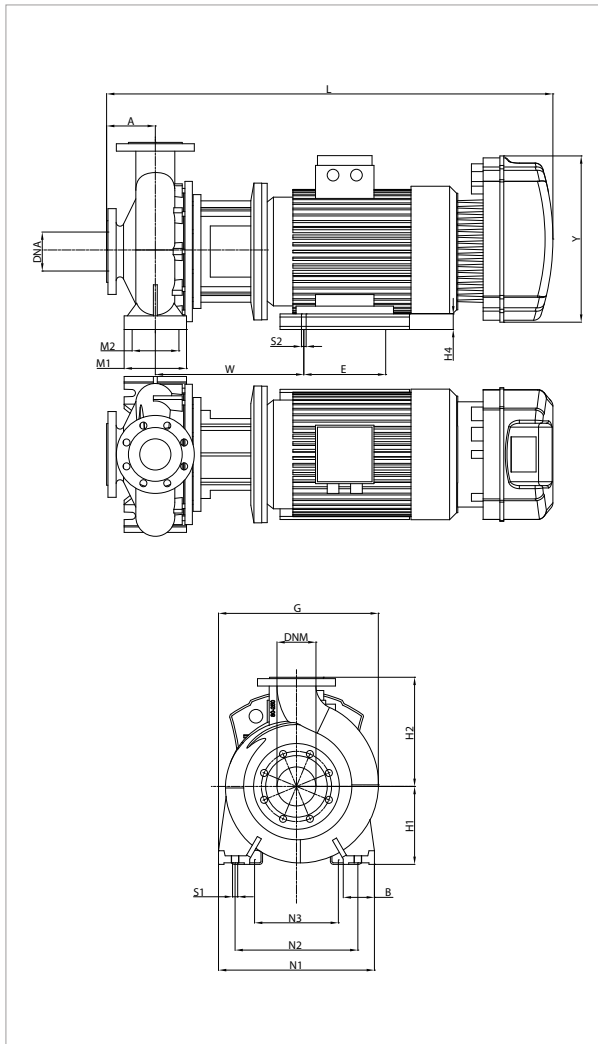

See hydraulic efficiency details on page 241.

The performance curves are based on kinematic viscosity values = 1 mm²/s and density equal to 1000 kg/m³. Curve tolerance according to ISO 9906.

MODEL	MCE MODEL	POWER INPUT 50 Hz	P2 NOMINAL		In A
			kW	HP	
NKM-GE80-250/270/A/BAQE/11/4 MCE150/P	MCE150/P	3 x 400 ~V	11,0	15,0	27,2

MODEL	A	B	E	G	H1	H2	H4	L	M1	M2	N1	N2	S1	S2	W	X	Y	DNA	DNM	PACKING DIMENSIONS			WEIGHT kg
																				L/A	L/B	H	
NKM-GE80-250/270/A/BAQE/11/4 MCE150/P	125	80	210	140	200	280	40	1153	160	120	400	315	M14	M12	381	140	426	100	80	1386	526	676	237

NKM-GE 80-315 - STANDARDISED MONOBLOC CENTRIFUGAL ELECTRIC PUMPS



WITH INVERTER FOR CIRCULATION OR PRESSURISATION SYSTEMS

Pumped liquid temperature range: from -10 °C to +140 °C (MCE/C) - from -10 °C to +80 °C (MCE/P) - Maximum ambient temperature: +40 °C

≈ 1450 1/min

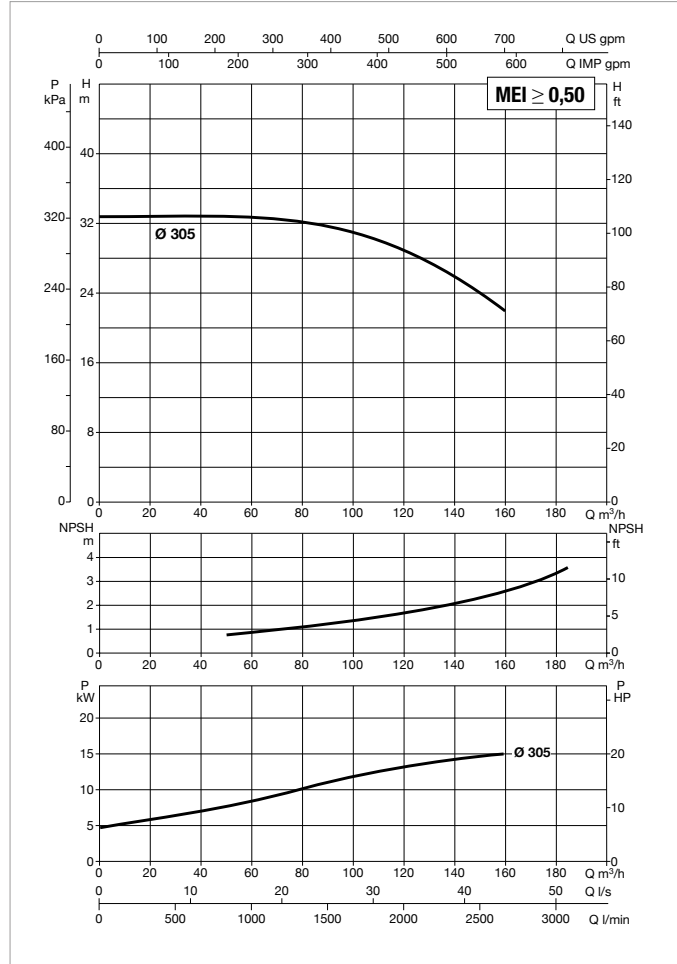
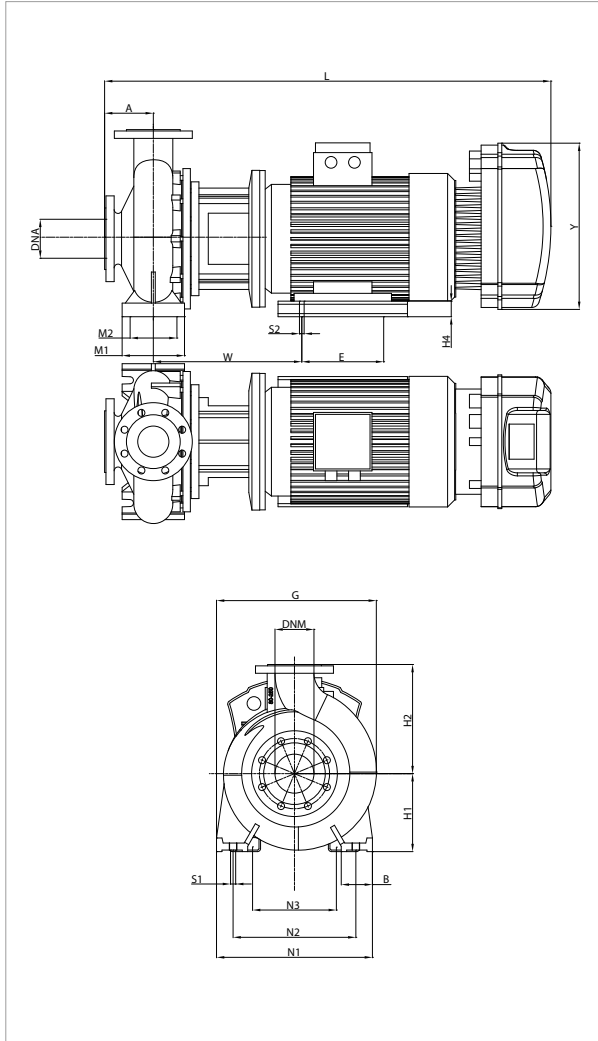

See hydraulic efficiency details on page 241.

The performance curves are based on kinematic viscosity values = 1 mm²/s and density equal to 1000 kg/m³. Curve tolerance according to ISO 9906.

MODEL	MCE MODEL	POWER INPUT 50 Hz	P2 NOMINAL		In A
			kW	HP	
NKM-GE 80-315/305/A/BAQE/15/4 T MCE150/C-P	MCE150/C - MCE150/P	3 x 400 -V	15,00	20,00	34,7

MODEL	A	B	E	G	H1	H2	H4	L	M1	M2	N1	N2	S1	S2	W	X	Y	DNA	DNM	PACKING DIMENSIONS			WEIGHT kg
																				L/A	L/B	H	
NKM-GE 80-315/305/A/BAQE/15/4 T MCE150/C-P	125	80	254	460	250	315	90	1188	160	120	400	315	M14	M12	402	140	426	100	80	1250	560	575	294

NKM-GE 100-200 - STANDARDISED MONOBLOC CENTRIFUGAL ELECTRIC PUMPS WITH INVERTER FOR CIRCULATION SYSTEMS



Pumped liquid temperature range: from -10 °C to +140 °C (MCE/C) - Maximum ambient temperature: +40 °C

≈ 1450 1/min

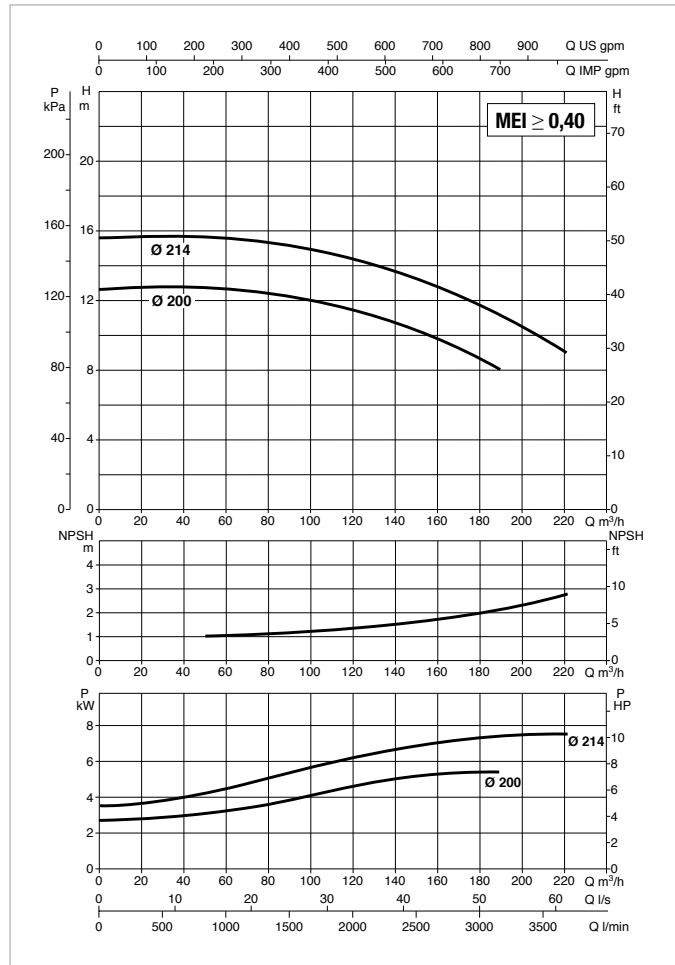
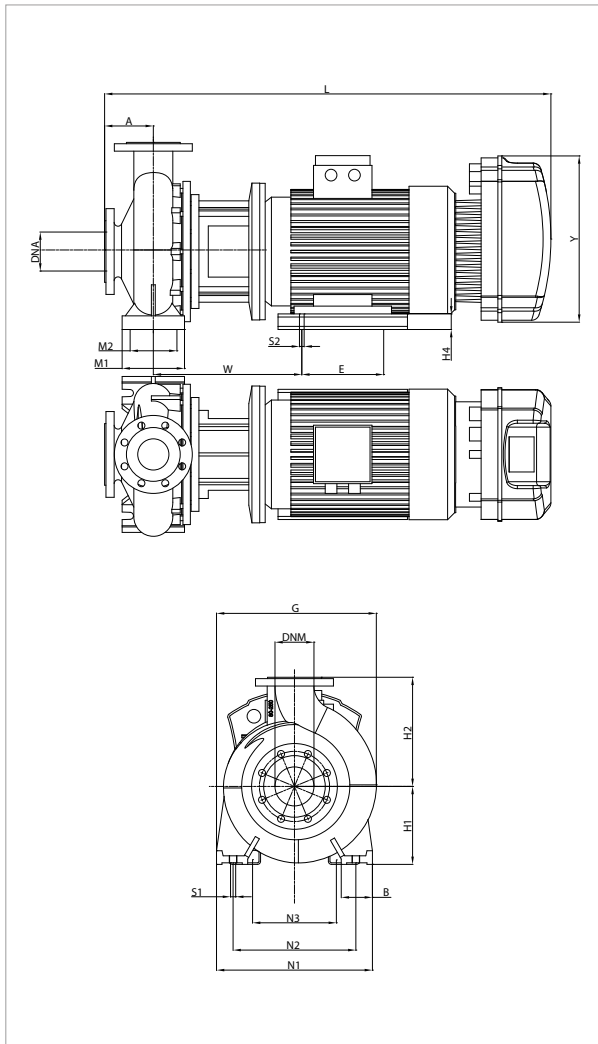

See hydraulic efficiency details on page 241.

The performance curves are based on kinematic viscosity values = 1 mm²/s and density equal to 1000 kg/m³. Curve tolerance according to ISO 9906.

MODEL	MCE MODEL	POWER INPUT 50 Hz	P2 NOMINAL		In A
			kW	HP	
NKM-GE 100-200/200/A/BAQE/5.5/4 T MCE55/C	MCE55/C	3 x 400 ~V	5,50	7,50	13,7
NKM-GE 100-200/214A/BAQE/7.5/4 T MCE110/C	MCE110/C	3 x 400 ~V	7,50	10,00	17,7

MODEL	A	B	G	H1	H2	L	M1	M2	N1	N2	S1	X	Y	DNA	DNM	PACKING DIMENSIONS			WEIGHT kg
																L/A	L/B	H	
NKM-GE 100-200/200/A/BAQE/5.5/4 T MCE55/C	125	80	392	200	280	938	160	120	360	280	M14	140	353	125	100	1100	550	620	169
NKM-GE 100-200/214A/BAQE/7.5/4 T MCE110/C	125	80	392	200	280	1026	160	120	360	280	M14	140	426	125	100	1100	550	620	181

NKM-GE 100-250 - STANDARDISED MONOBLOC CENTRIFUGAL ELECTRIC PUMPS WITH INVERTER FOR CIRCULATION SYSTEMS



Pumped liquid temperature range: from -10 °C to +140 °C (MCE/C) - Maximum ambient temperature: +40 °C

≈ 1450 1/min

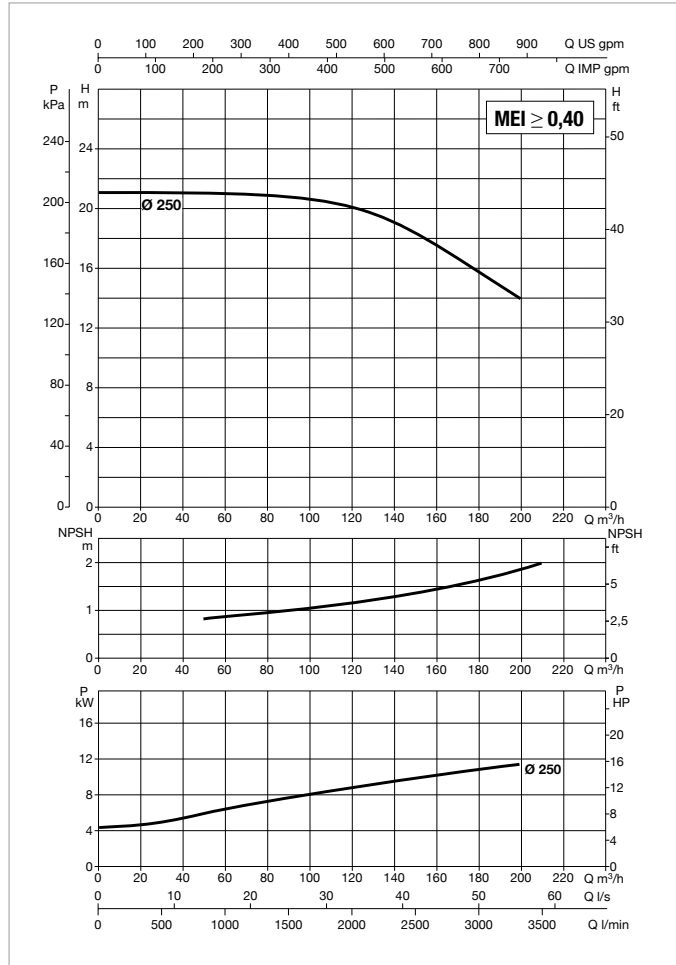
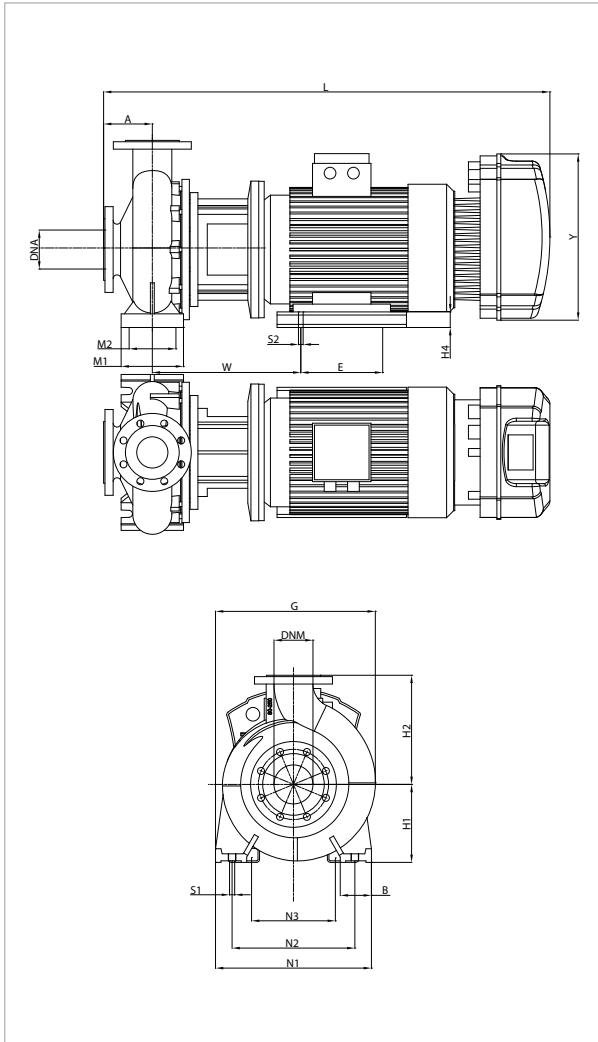

See hydraulic efficiency details on page 241.

The performance curves are based on kinematic viscosity values = 1 mm²/s and density equal to 1000 kg/m³. Curve tolerance according to ISO 9906.

MODEL	MCE MODEL	POWER INPUT 50 Hz	P2 NOMINAL		In A
			kW	HP	
NKM-GE 100-250/250/A/BAQE/11/4 T MCE110/C	MCE110/C	3 x 400 ~V	11,00	15,00	26,0

MODEL	A	B	E	G	H1	H2	H4	L	M1	M2	N1	N2	S1	S2	W	X	Y	DNA	DNM	PACKING DIMENSIONS			WEIGHT kg
																				L/A	L/B	H	
NKM-GE 100-250/250/A/BAQE/11/4 T MCE110/C	140	80	210	424	225	280	65	1123	160	120	400	315	M14	M12	381	140	426	125	100	1250	560	575	245

NKM-GE 100-250 - STANDARDISED MONOBLOC CENTRIFUGAL ELECTRIC PUMPS WITH INVERTER FOR PRESSURISATION SYSTEMS



Pumped liquid temperature range: from -10 °C to +80 °C (MCE/P) - Maximum ambient temperature: +40 °C

≈ 1450 1/min

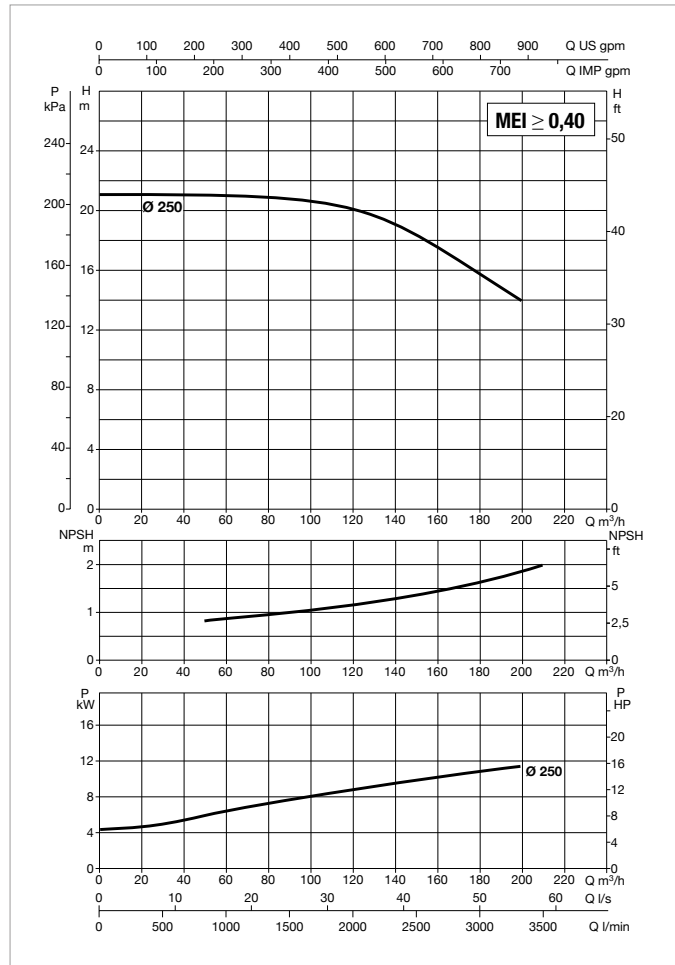
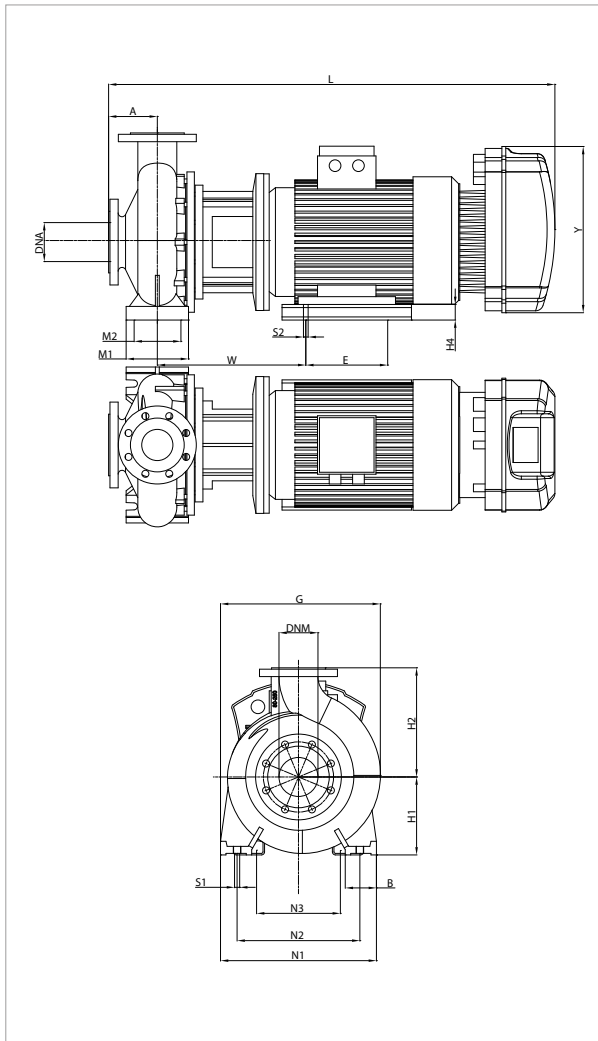

See hydraulic efficiency details on page 241.
The performance curves are based on kinematic viscosity values = 1 mm²/s and density equal to 1000 kg/m³. Curve tolerance according to ISO 9906.

MODEL	MCE MODEL	POWER INPUT 50 Hz	P2 NOMINAL		In A
			kW	HP	
NKM-GE100-250/250/A/BAQE/11/4 MCE150/P	MCE150/P	3 x 400 -V	11,0	15,0	27,2

MODEL	A	B	E	G	H1	H2	H4	L	M1	M2	N1	N2	S1	S2	W	X	Y	DNA	DNM	PACKING DIMENSIONS			WEIGHT kg
																				L/A	L/B	H	
NKM-GE100-250/250/A/BAQE/11/4 MCE150/P	140	80	210	424	225	280	65	1168	160	120	400	315	M14	M12	381	140	426	125	100	1386	526	676	245

NKM-GE 100-250 - STANDARDISED MONOBLOC CENTRIFUGAL ELECTRIC PUMPS

WITH INVERTER FOR CIRCULATION OR PRESSURISATION SYSTEMS



Pumped liquid temperature range: from -10 °C to +140 °C (MCE/C) - from -10 °C to +80 °C (MCE/P) - Maximum ambient temperature: +40 °C
 ≅ 1450 l/min

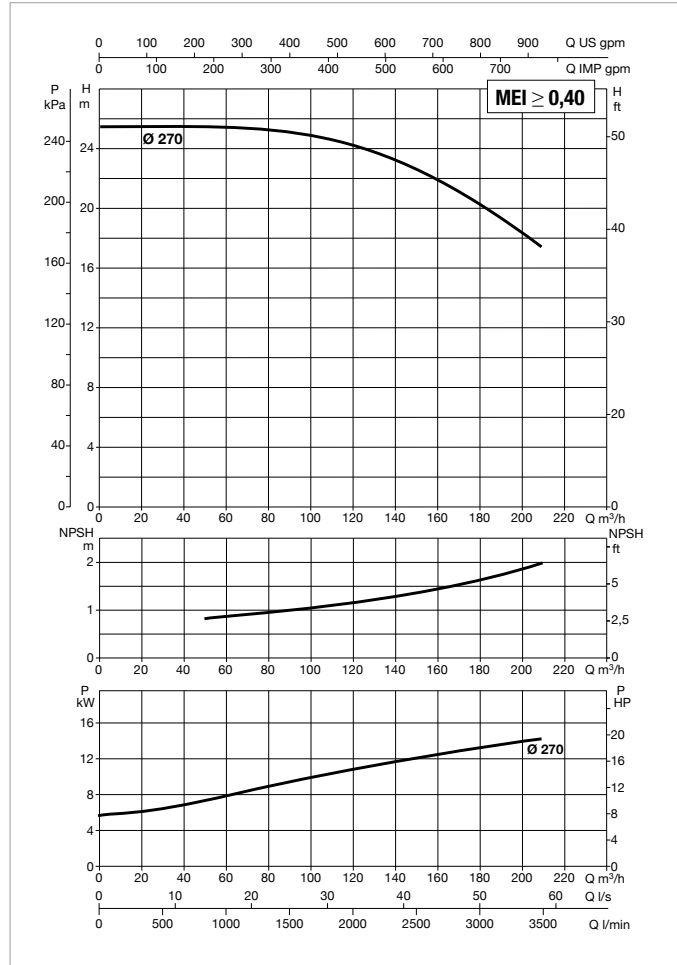
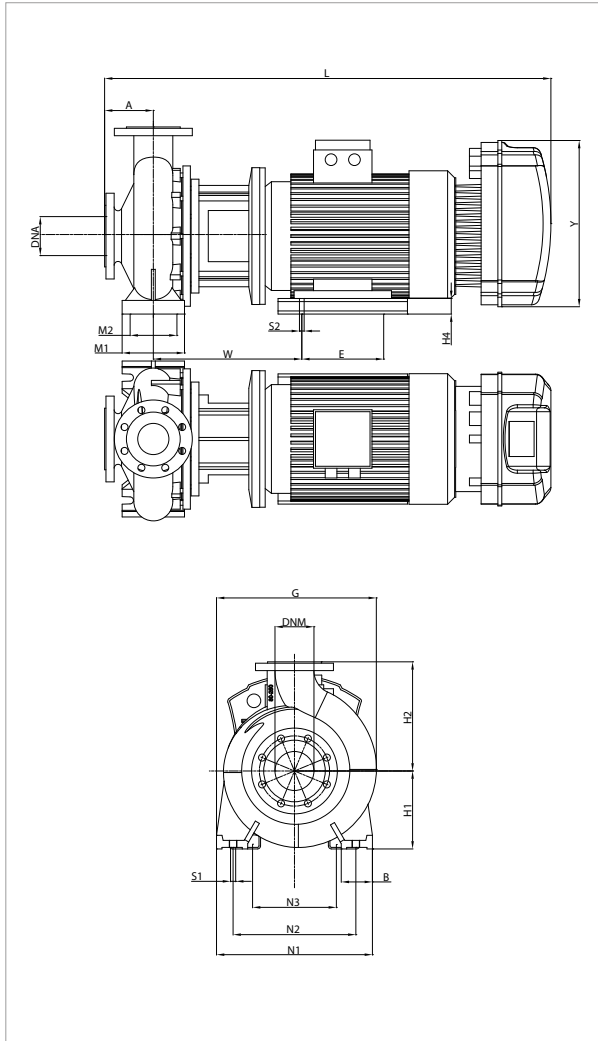

See hydraulic efficiency details on page 241.

The performance curves are based on kinematic viscosity values = 1 mm²/s and density equal to 1000 kg/m³. Curve tolerance according to ISO 9906.

MODEL	MCE MODEL	POWER INPUT 50 Hz	P2 NOMINAL		In A
			kW	HP	
NKM-GE 100-250/270/A/BAQE/15/4 T MCE150/C-P	MCE150/C - MCE150/P	3 x 400 -V	15,00	20,00	33,2

MODEL	A	B	E	G	H1	H2	H4	L	M1	M2	N1	N2	S1	S2	W	X	Y	DNA	DNM	PACKING DIMENSIONS			WEIGHT kg
																				L/A	L/B	H	
NKM-GE 100-250/270/A/BAQE/15/4 T MCE150/C-P	140	80	254	424	225	280	65	1203	160	120	400	315	M14	M12	381	140	426	125	100	1250	560	575	268

NKM-GE 125-250 - STANDARDISED MONOBLOC CENTRIFUGAL ELECTRIC PUMPS

WITH INVERTER FOR CIRCULATION OR PRESSURISATION SYSTEMS



Pumped liquid temperature range: from -10 °C to +140 °C (MCE/C) - from -10 °C to +80 °C (MCE/P) - Maximum ambient temperature: +40 °C
 ≅ 1450 l/min

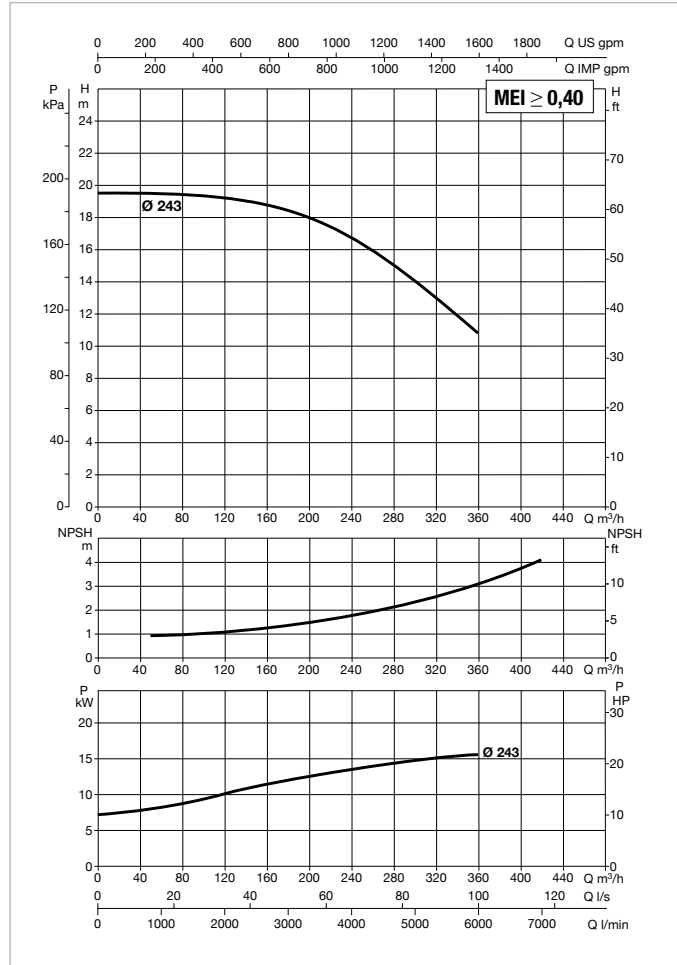
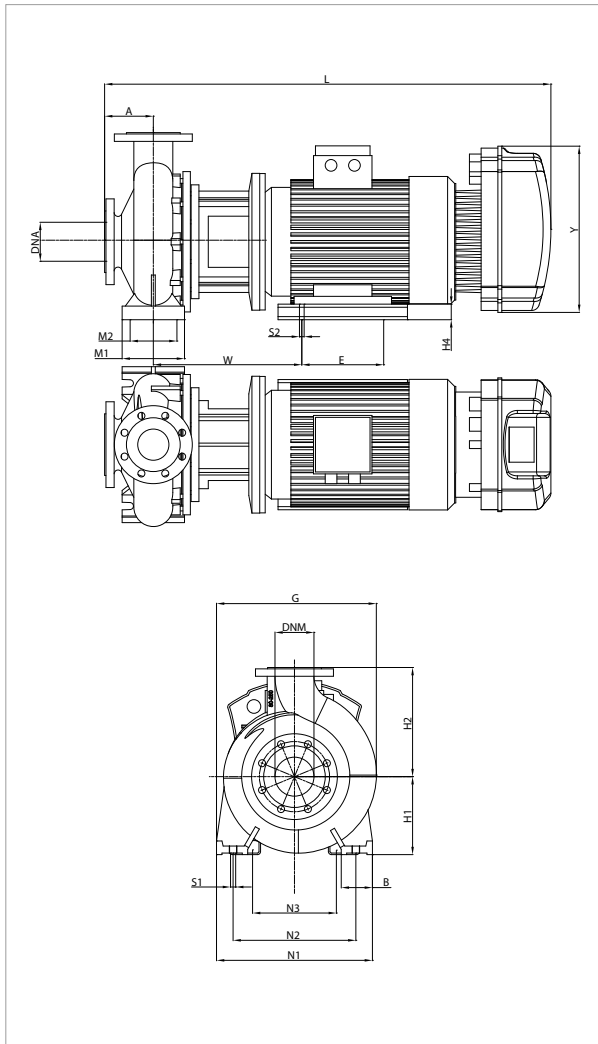

See hydraulic efficiency details on page 241.

The performance curves are based on kinematic viscosity values = 1 mm²/s and density equal to 1000 kg/m³. Curve tolerance according to ISO 9906.

MODEL	MCE MODEL	POWER INPUT 50 Hz	P2 NOMINAL		In A
			kW	HP	
NKM-GE 125-250/243/A/BAQE/15/4 T MCE150/C-P	MCE150/C - MCE150/P	3 x 400 -V	15,00	20,00	36,7

MODELLO	A	B	E	G	H1	H2	H4	L	M1	M2	N1	N2	S1	S2	W	X	Y	DNA	DNM	PACKING DIMENSIONS			WEIGHT kg
																				L/A	L/B	H	
NKM-GE 125-250/243/A/BAQE/15/4 T MCE150/C-P	140	80	254	472	250	355	90	1203	160	120	400	315	M14	M12	381	140	426	150	125	1500	660	725	305

NKM-GE 150-200 - STANDARDISED MONOBLOC CENTRIFUGAL ELECTRIC PUMPS WITH INVERTER FOR CIRCULATION SYSTEMS



Pumped liquid temperature range: from -10 °C to +140 °C (MCE/C) - Maximum ambient temperature: +40 °C

≈ 1450 1/min

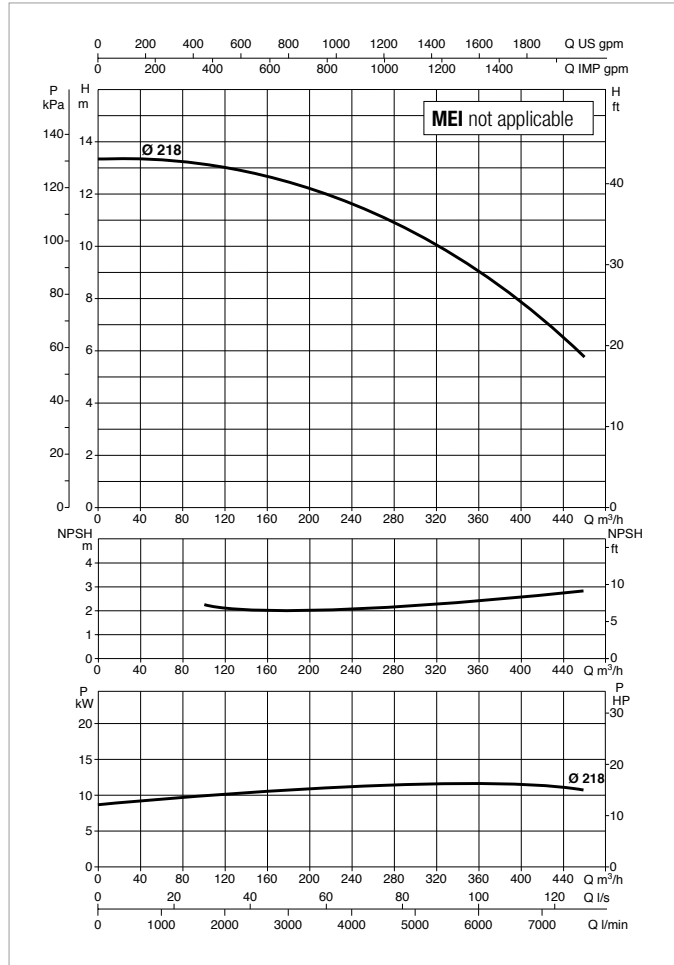
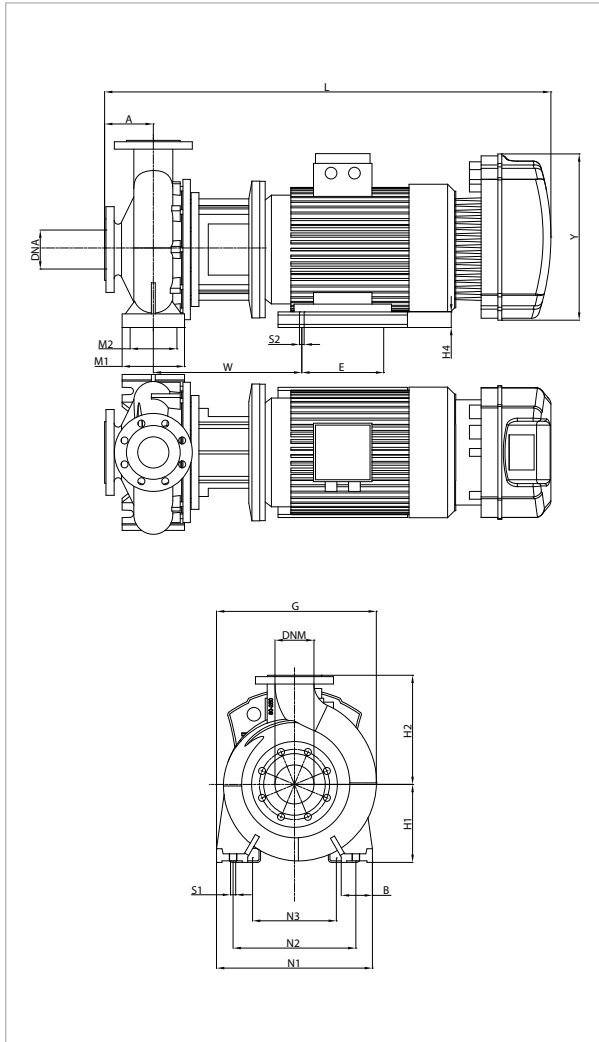

See hydraulic efficiency details on page 241.

The performance curves are based on kinematic viscosity values = 1 mm²/s and density equal to 1000 kg/m³. Curve tolerance according to ISO 9906.

MODEL	MCE MODEL	POWER INPUT 50 Hz	P2 NOMINAL		In A
			kW	HP	
NKM-GE 150-200/218/A/BAQE/11/4 T MCE110/C	MCE110/C	3 x 400 ~V	11,00	15,00	27,8

MODEL	A	B	E	G	H1	H2	H4	L	M1	M2	N1	N2	S1	S2	W	X	Y	DNA	DNM	PACKING DIMENSIONS			WEIGHT kg
																				L/A	L/B	H	
NKM-GE 150-200/218/A/BAQE/11/4 T MCE110/C	160	100	210	593	280	400	120	1243	200	150	550	450	M16	M12	381	140	426	200	150	1500	660	725	406

NKP-GE - 2 POLES

STANDARDISED MONOBLOC CENTRIFUGAL ELECTRIC PUMPS WITH INVERTER

SELECTION TABLE - NKP-GE 32

MODEL	Q=m ³ /h	0	6	12	18	24	30	36	42
	Q=l/min	0	100	200	300	400	500	600	700
NKP-GE 32-125.1/115/1.1/2	H (m)	17.2	17	15	12.5				
NKP-GE 32-125.1/125/1.5/2		21	20.8	19	16.8				
NKP-GE 32-125.1/140/2.2/2		27	26.9	25.9	23	19.5			
NKP-GE 32-125/110/ 1.1 /2		15.8	15.2	14.5	12.9	9.9			
NKP-GE 32-125/120/ 1.5 /2		19.3	18.9	18.2	16.8	14.5			
NKP-GE 32-125/130/ 2.2 /2		23.6	23.1	23	21.6	19.6	16.8		
NKP-GE 32-125/142/ 3 /2		28.6	28	27.6	26.5	24.6	21.8	17.9	
NKP-GE 32-160.1 155/2.2/2		31.7	32.4	31	26.7				
NKP-GE 32-160.1 166/3 /2		36.7	37.3	36.3	32.8	27			
NKP-GE 32-160.1 177/4/2		42.7	43.4	42.6	38.5	33.9			
NKP-GE 32-160/151 /3 /2		30.5	30	29	27	24	19.5		
NKP-GE 32-160/163 /4 /2		36.2	36	35	33.5	30.5	27	22	
NKP-GE 32-160/177 /5,5/2		43.5	43.2	42.6	41.5	39	36	31.5	25.5
NKP-GE 32-200.1 188/4 /2		45.3	44.4	40.8	34.4	26.8			
NKP-GE 32-200.1 205/5.5/2		56.6	55.7	52	45.8	36.2			
NKP-GE 32-200/190/ 5.5 /2		46.9	46.5	45	43	40	35	29	
NKP-GE 32-200/210/ 7.5 /2	58.8	58	57	56	53	49	44		

SELECTION TABLE - NKP-GE 40

MODEL	Q=m ³ /h	0	6	12	18	24	30	36	42	48	54	60	66	72
	Q=l/min	0	100	200	300	400	500	600	700	800	900	1000	1100	1200
NKP-GE 40-125/107/ 1.5 /2	H (m)	14.7	14.5	14.3	13.8	13	11.8	10.5	8.6	7				
NKP-GE 40-125/120/ 2.2 /2		19	18.7	18.4	17.8	17	15.9	14.6	13	11				
NKP-GE 40-125/130/ 3 /2		22.8	22.5	22.3	22	21.2	20.2	19	17.4	15.5	13.5			
NKP-GE 40-125/139/ 4 /2		26.4	26.2	26	25.6	25	24	23	21.5	19.5	17.5	15		
NKP-GE 40-160/158/ 5.5 /2		33.7			34	33.4	32.4	31	29.5	27	24			
NKP-GE 40-160/172/ 7.5 /2		40.7			40.2	40.1	39.8	38.5	37.5	35.5	33	30	26.5	
NKP-GE 40-200/210/11 /2		57.1	57	57	56.8	56.5	56	55	53	50	47	43.5	39	
NKP-GE 40-250/230/15 /2		72.5			72.5	72	70	68	66	62.5	60	56	51.5	

NKP-GE - 2 POLES

STANDARDISED MONOBLOC CENTRIFUGAL ELECTRIC PUMPS WITH INVERTER

SELECTION TABLE - NKP-GE 50

MODEL	Q=m ³ /h	0	6	12	18	24	30	36	42	48	54	60	66	72	78	84	90	102	114
	Q=l/min	0	100	200	300	400	500	600	700	800	900	1000	1100	1200	1300	1400	1500	1700	1900
NKP-GE 50-125/115/ 3 /2	H (m)	17				16.5	16	15.5	15	14.5	13.7	13	12	11	10	9			
NKP-GE 50-125/125/ 4 /2		20.5				20	19.5	19.1	18.5	18	17.5	16.5	15.8	14.8	14	12.5	11.5		
NKP-GE 50-125/135/ 5.5 /2		24				23.6	23.5	23.2	22.8	22.2	21.5	21	20	19.1	18.5	17.5	16.5	13.4	
NKP-GE 50-125/144/ 7.5 /2		28				27.8	27.5	27.3	27	26.5	25.8	25.3	24.5	23.5	23	21.5	20.5	18	15.5
NKP-GE 50-160/153/ 7.5 /2		31.9				31.5	31.5	31.5	31.2	31	30.5	29.5	28.5	27.5	26	25	23.5		
NKP-GE 50-160/169/11 /2		39.6					39.5	39.3	39.1	39	38.5	38	37.2	36.5	35	34	32.5		
NKP-GE 50-200/200/15 /2		55.1					54.7	54.6	54	53.5	52	51	49	47.5	45.5	43	41		

SELECTION TABLE - NKP-GE 65

MODEL	Q=m ³ /h	0	6	12	18	24	30	36	42	48	54	60	66	72	78	84	90	102	114	120	150
	Q=l/min	0	100	200	300	400	500	600	700	800	900	1000	1100	1200	1300	1400	1500	1700	1900	2000	2500
NKP-GE 65-125/127/ 5.5 /2	H (m)	19.5						19	18.9	18.7	18.4	18.1	17.5	17.2	16.9	16.5	15.8	14.5	13	12	
NKP-GE 65-125/137/ 7.5 /2		23.5						23.1	23	22.8	22.6	22.5	22	21.6	21.1	20.7	20.2	19	17.5	14.8	12
NKP-GE 65-160/157/11 /2		32.5								32.3	32	31.9	1.3	30.2	30	29.2	28.7	27	24.8	23.6	
NKP-GE 65-160/173/15 /2		40.1								39.7	39.6	39.5	39.5	39	38.5	38.2	37.5	36	34.5	33.5	26.9

SELECTION TABLE - NKP-GE 80

MODEL	Q=m ³ /h	0	6	12	18	24	30	36	42	48	54	60	66	72	78	84	90	102	114	120	150	180	210	240
	Q=l/min	0	100	200	300	400	500	600	700	800	900	1000	1100	1200	1300	1400	1500	1700	1900	2000	2500	3000	3500	4000
NKP-GE 80-160/147-127/11 /2	H (m)	24.5															22	21.4	20.4	20	17.4	16.8	12	
NKP-GE 80-160/153/15 /2		30.5																29	28.4	27.5	27	24.5	21.3	18.3

NKP-GE 32-125.1 - STANDARDISED MONOBLOC CENTRIFUGAL ELECTRIC PUMPS WITH INVERTER FOR CIRCULATION SYSTEMS



Pumped liquid temperature range: from -10 °C to +140 °C (MCE/C) - Maximum ambient temperature: +40 °C

≈ 2900 1/min

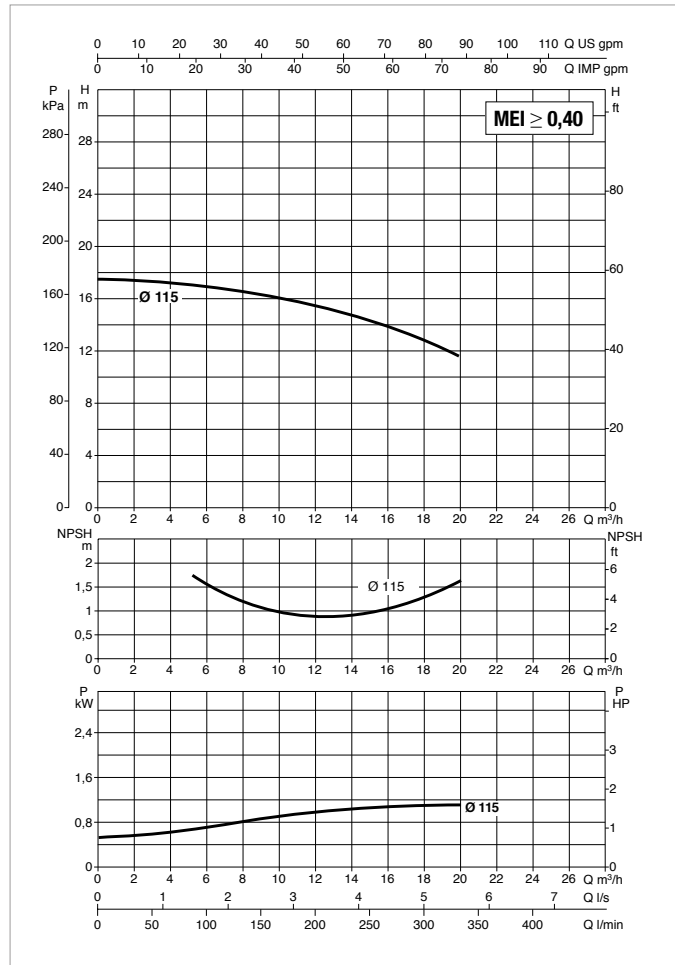
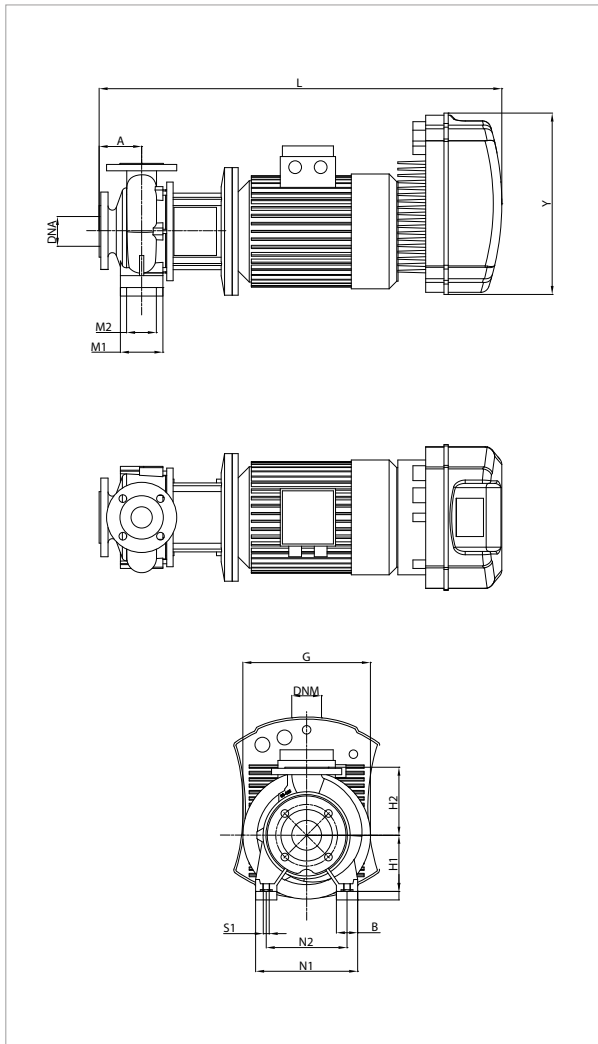

See hydraulic efficiency details on page 241.

The performance curves are based on kinematic viscosity values = 1 mm²/s and density equal to 1000 kg/m³. Curve tolerance according to ISO 9906.

MODEL	MCE MODEL	POWER INPUT 50 Hz	P2 NOMINAL		In A
			kW	HP	
NKP-GE 32-125.1/115/A/BAQE/1.1/2 M MCE11/C	MCE11/C	1 x 230 ~V	1,10	1,5	10,9
NKP-GE 32-125.1/115/A/BAQE/1.1/2 T MCE30/C	MCE30/C	3 x 400 ~V	1,10	1,5	t.b.d.

MODEL	A	B	G	H1	H2	L	M1	M2	N1	N2	S1	X	Y	DNA	DNM	PACKING DIMENSIONS			WEIGHT kg
																L/A	L/B	H	
NKP-GE 32-125.1/115/A/BAQE/1.1/2 M MCE11/C	80	50	234	112	140	660	100	70	190	140	M10	100	262	50	32	800	400	400	51
NKP-GE 32-125.1/115/A/BAQE/1.1/2 T MCE30/C	80	50	234	112	140	727	100	70	190	140	M10	100	353	50	32	800	400	400	53,6

NKP-GE 32-125.1 - STANDARDISED MONOBLOC CENTRIFUGAL ELECTRIC PUMPS WITH INVERTER FOR CIRCULATION SYSTEMS



Pumped liquid temperature range: from -10 °C to +140 °C (MCE/C) - Maximum ambient temperature: +40 °C

≈ 2900 1/min

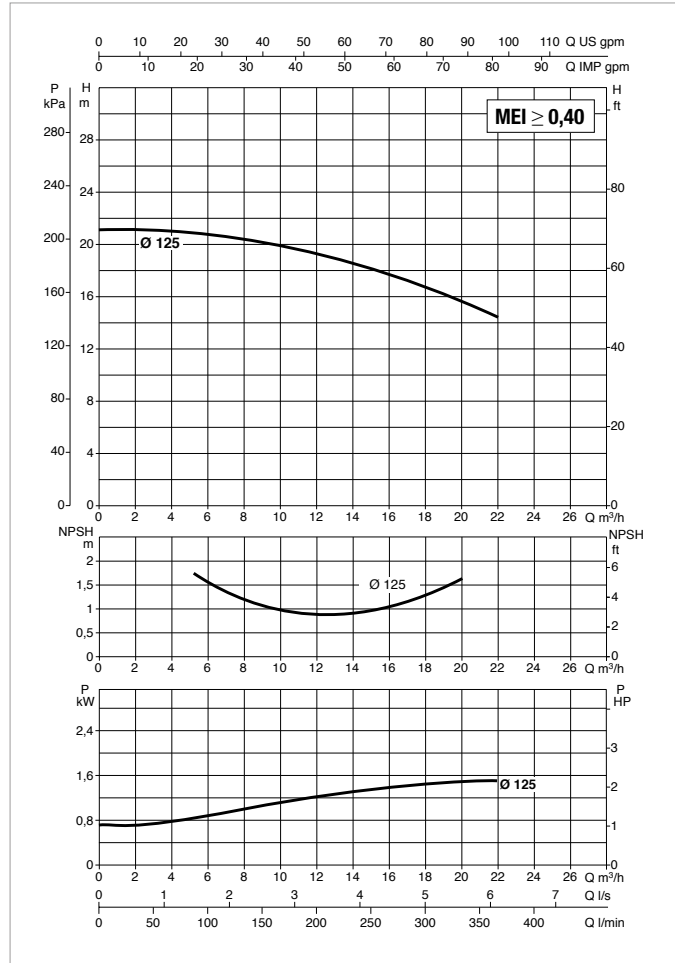
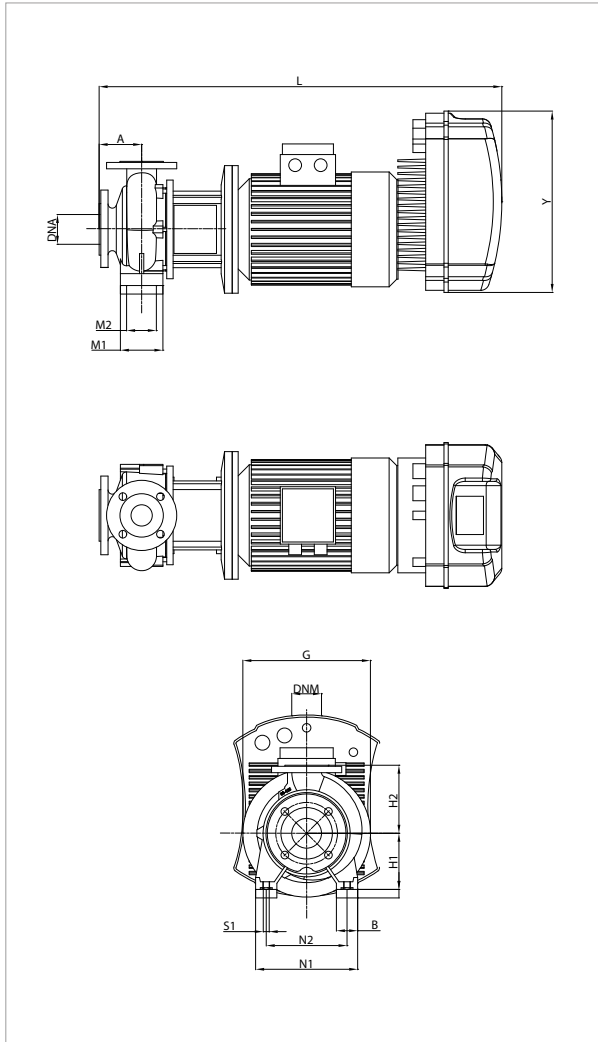

See hydraulic efficiency details on page 241.

The performance curves are based on kinematic viscosity values = 1 mm²/s and density equal to 1000 kg/m³. Curve tolerance according to ISO 9906.

MODEL	MCE MODEL	POWER INPUT 50 Hz	P2 NOMINAL		In A
			kW	HP	
NKP-GE 32-125.1/125/A/BAQE/1.5/2 M MCE15/C	MCE15/C	1 x 230 ~V	1,50	2,0	14,7
NKP-GE 32-125.1/125/A/BAQE/1.5/2 T MCE30/C	MCE30/C	3 x 400 ~V	1,50	2,0	t.b.d.

MODEL	A	B	G	H1	H2	L	M1	M2	N1	N2	S1	X	Y	DNA	DNM	PACKING DIMENSIONS			WEIGHT kg
																L/A	L/B	H	
NKP-GE 32-125.1/125/A/BAQE/1.5/2 M MCE15/C	80	50	234	112	140	673	100	70	190	140	M10	100	262	50	32	800	400	400	56
NKP-GE 32-125.1/125/A/BAQE/1.5/2 T MCE30/C	80	50	234	112	140	740	100	70	190	140	M10	100	353	50	32	800	400	400	58,6

NKP-GE 32-125.1 - STANDARDISED MONOBLOC CENTRIFUGAL ELECTRIC PUMPS WITH INVERTER FOR PRESSURISATION SYSTEMS



Pumped liquid temperature range: from -10 °C to +80 °C (MCE/P) - Maximum ambient temperature: +40 °C

≈ 2900 1/min

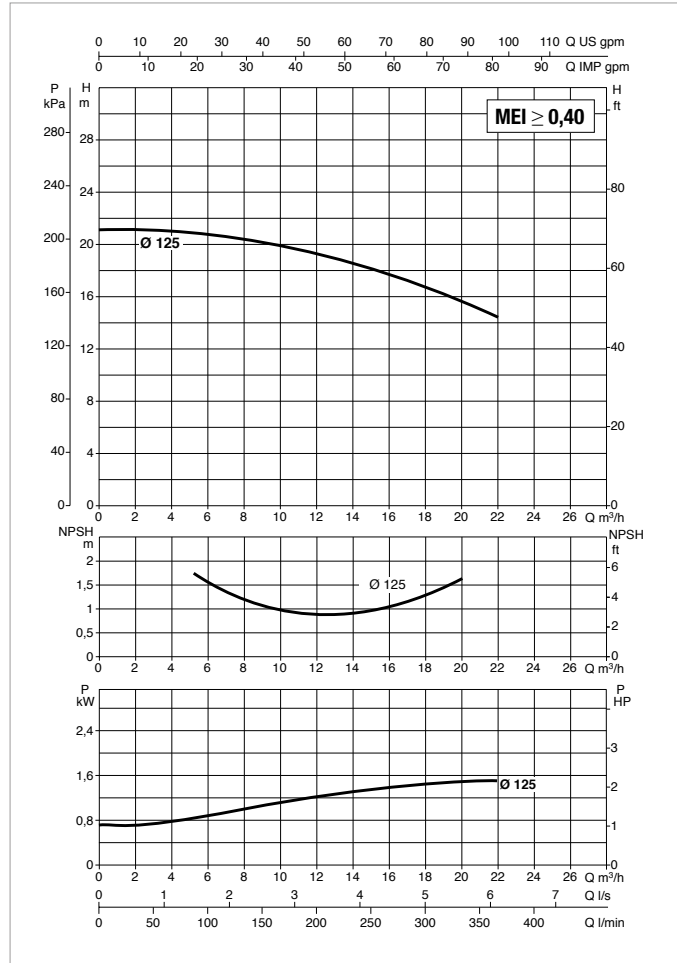
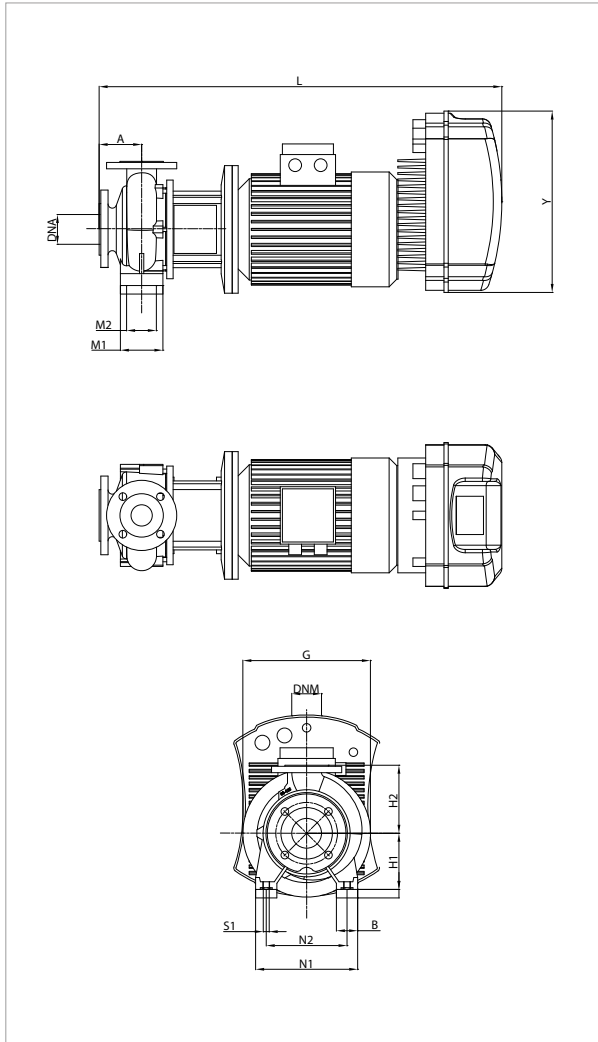

See hydraulic efficiency details on page 241.

The performance curves are based on kinematic viscosity values = 1 mm²/s and density equal to 1000 kg/m³. Curve tolerance according to ISO 9906.

MODEL	MCE MODEL	POWER INPUT 50 Hz	P2 NOMINAL		In A
			kW	HP	
NKP-GE32-125.1/125/A/BAQE /1.5/2 MCE22/P	MCE22/P	1 x 230 ~V	1,5	2,0	13,4

MODEL	A	B	G	H1	H2	L	M1	M2	N1	N2	S1	X	Y	DNA	DNM	PACKING DIMENSIONS			WEIGHT kg
																L/A	L/B	H	
NKP-GE32-125.1/125/A/BAQE /1.5/2 MCE22/P	80	50	234	112	140	673	100	70	190	140	M10	100	262	50	32	800	400	400	56

NKP-GE 32-125.1 - STANDARDISED MONOBLOC CENTRIFUGAL ELECTRIC PUMPS WITH INVERTER FOR CIRCULATION SYSTEMS



Pumped liquid temperature range: from -10 °C to +140 °C (MCE/C) - Maximum ambient temperature: +40 °C

≈ 2900 1/min

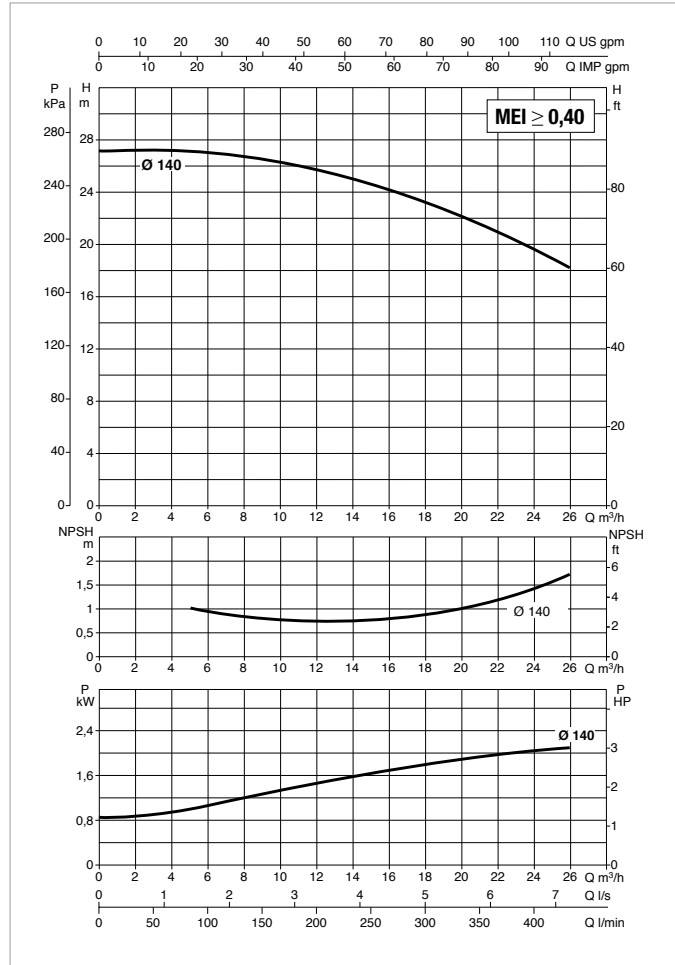
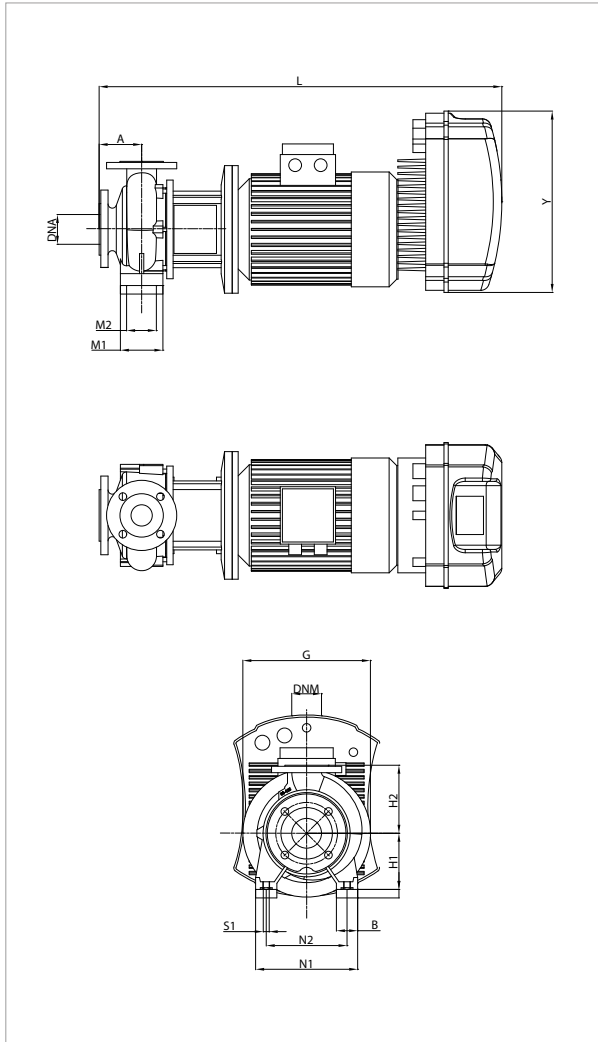

See hydraulic efficiency details on page 241.

The performance curves are based on kinematic viscosity values = 1 mm²/s and density equal to 1000 kg/m³. Curve tolerance according to ISO 9906.

MODEL	MCE MODEL	POWER INPUT 50 Hz	P2 NOMINAL		In A
			kW	HP	
NKP-GE 32-125.1/140/A/BAQE/2.2/2 M MCE22/C	MCE22/C	1 x 230 ~V	2,20	3,0	19,9
NKP-GE 32-125.1/140/A/BAQE/2.2/2 T MCE30/C	MCE30/C	3 x 400 ~V	2,20	3,0	5,6

MODEL	A	B	G	H1	H2	L	M1	M2	N1	N2	S1	X	Y	DNA	DNM	PACKING DIMENSIONS			WEIGHT kg
																L/A	L/B	H	
NKP-GE 32-125.1/140/A/BAQE/2.2/2 M MCE22/C	80	50	234	112	140	698	100	70	190	140	M10	100	262	50	32	800	400	400	58
NKP-GE 32-125.1/140/A/BAQE/2.2/2 T MCE30/C	80	50	234	112	140	765	100	70	190	140	M10	100	353	50	32	800	400	400	60,6

NKP-GE 32-125.1 - STANDARDISED MONOBLOC CENTRIFUGAL ELECTRIC PUMPS WITH INVERTER FOR PRESSURISED SYSTEMS



Pumped liquid temperature range: from -10 °C to +80 °C (MCE/P) - Maximum ambient temperature: +40 °C

≈ 2900 1/min

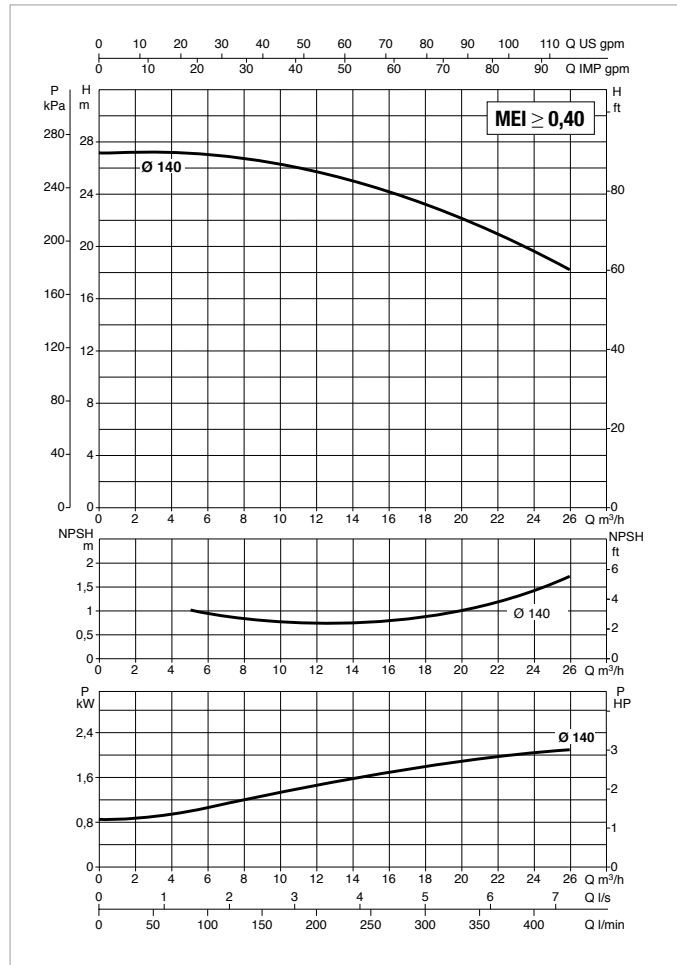
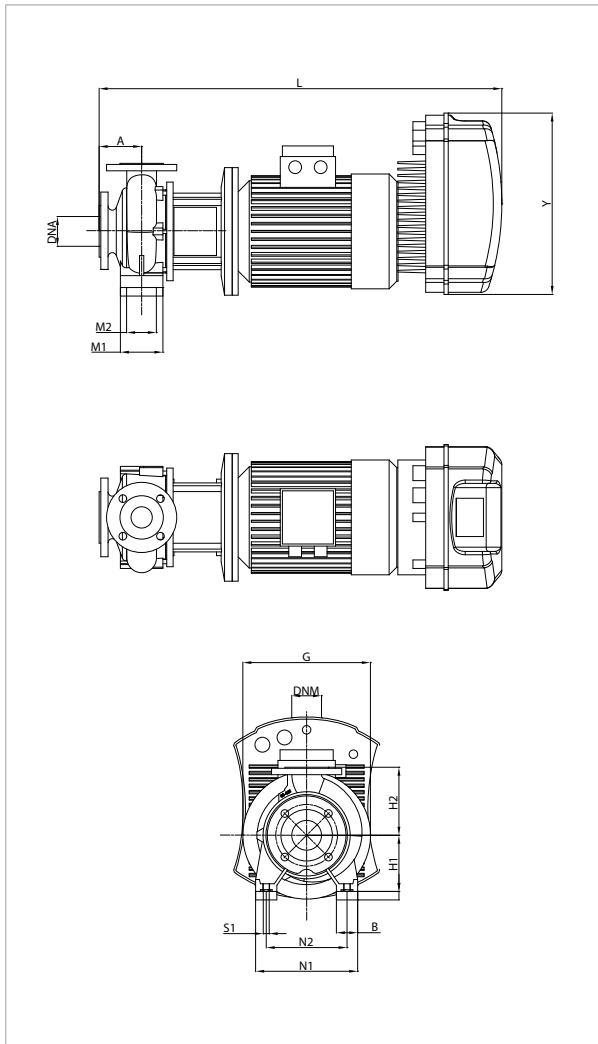

See hydraulic efficiency details on page 241.

The performance curves are based on kinematic viscosity values = 1 mm²/s and density equal to 1000 kg/m³. Curve tolerance according to ISO 9906.

MODEL	MCE MODEL	POWER INPUT 50 Hz	P2 NOMINAL		In A
			kW	HP	
NKP-GE 32-125.1/140/A/BAQE/2.2/2 M MCE22/P	MCE22/P	3 x 400 ~V	2,2	3,0	18,47

MODEL	A	B	G	H1	H2	L	M1	M2	N1	N2	S1	X	Y	DNA	DNM	PACKING DIMENSIONS			WEIGHT kg
																L/A	L/B	H	
NKP-GE 32-125.1/140/A/BAQE/2.2/2 M MCE22/P	80	50	234	112	140	698	100	70	190	140	M10	100	262	50	32	800	400	400	58

NKP-GE 32-125 - STANDARDISED MONOBLOC CENTRIFUGAL ELECTRIC PUMPS WITH INVERTER FOR CIRCULATION SYSTEMS



Pumped liquid temperature range: from -10 °C to +140 °C (MCE/C) - Maximum ambient temperature: +40 °C

≈ 2900 1/min

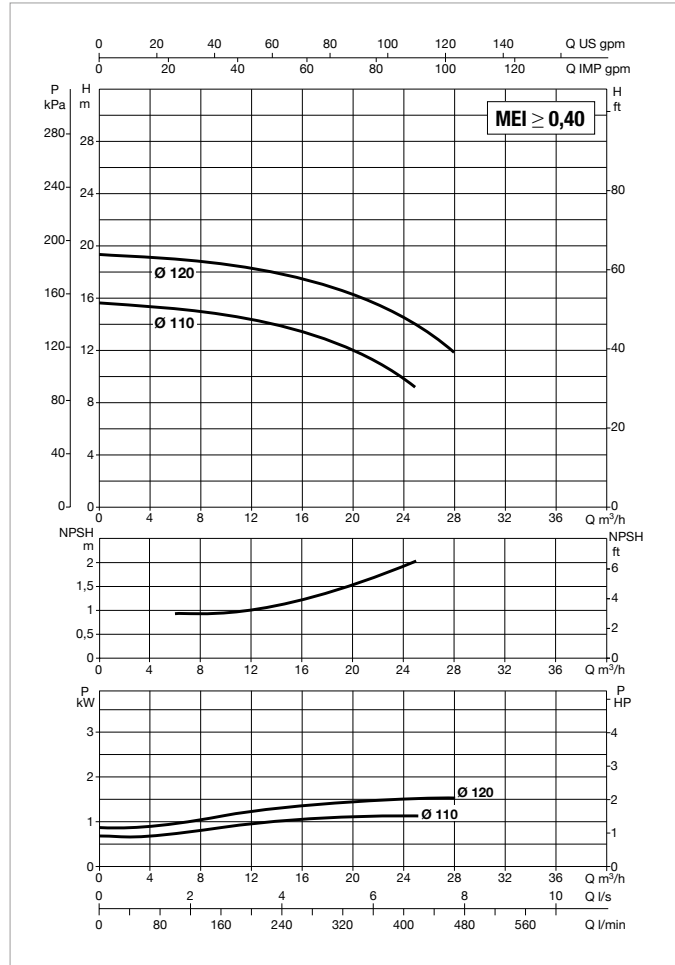
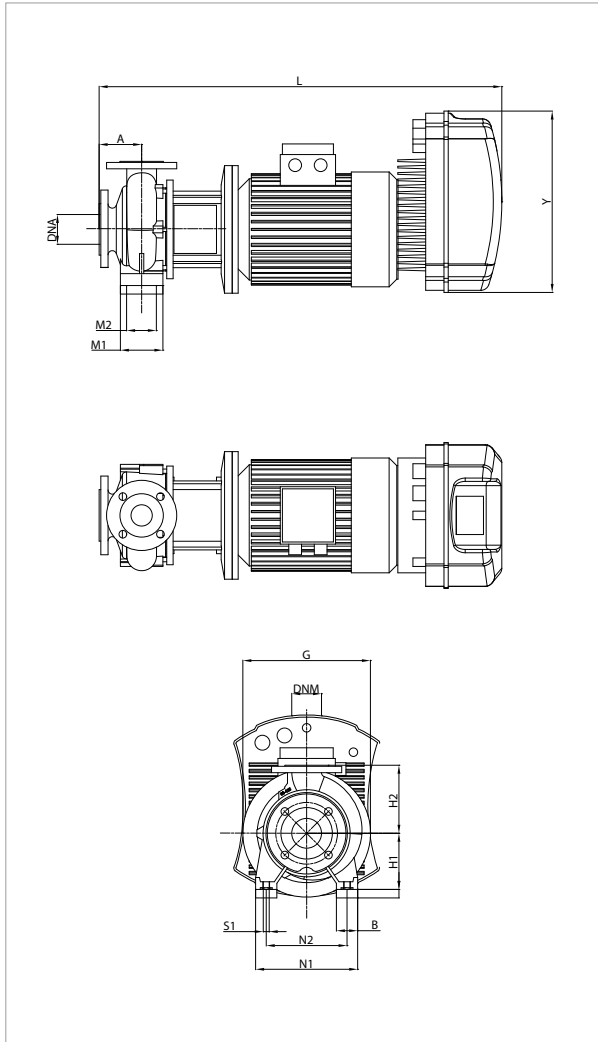

See hydraulic efficiency details on page 241.

The performance curves are based on kinematic viscosity values = 1 mm²/s and density equal to 1000 kg/m³. Curve tolerance according to ISO 9906.

MODEL	MCE MODEL	POWER INPUT 50 Hz	P2 NOMINAL		In A
			kW	HP	
NKP-GE 32-125/110/A/BAQE/1.1/2 M MCE11/C	MCE11/C	1 x 230 ~V	1,10	1,5	13,7
NKP-GE 32-125/110/A/BAQE/1.1/2 T MCE30/C	MCE30/C	3 x 400 ~V	1,10	1,5	t.b.d.
NKP-GE 32-125/120/A/BAQE/1.5/2 M MCE15/C	MCE15/C	1 x 230 ~V	1,50	2,0	17,9
NKP-GE 32-125/120/A/BAQE/1.5/2 T MCE30/C	MCE30/C	3 x 400 ~V	1,50	2,0	4,1

MODEL	A	B	G	H1	H2	L	M1	M2	N1	N2	S1	X	Y	DNA	DNM	PACKING DIMENSIONS			WEIGHT kg
																L/A	L/B	H	
NKP-GE 32-125/110/A/BAQE/1.1/2 M MCE11/C	80	50	234	112	140	660	100	70	190	140	M10	100	262	50	32	800	400	400	44
NKP-GE 32-125/110/A/BAQE/1.1/2 T MCE30/C	80	50	234	112	140	727	100	70	190	140	M10	100	353	50	32	800	400	400	46,6
NKP-GE 32-125/120/A/BAQE/1.5/2 M MCE15/C	80	50	234	112	140	673	100	70	190	140	M10	100	262	50	32	800	400	400	56
NKP-GE 32-125/120/A/BAQE/1.5/2 T MCE30/C	80	50	234	112	140	740	100	70	190	140	M10	100	353	50	32	800	400	400	58,6

NKP-GE 32-125 - STANDARDISED MONOBLOC CENTRIFUGAL ELECTRIC PUMPS WITH INVERTER FOR CIRCULATION SYSTEMS

MCE-C

Pumped liquid temperature range: from -10 °C to +140 °C (MCE/C) - Maximum ambient temperature: +40 °C

≈ 2900 1/min

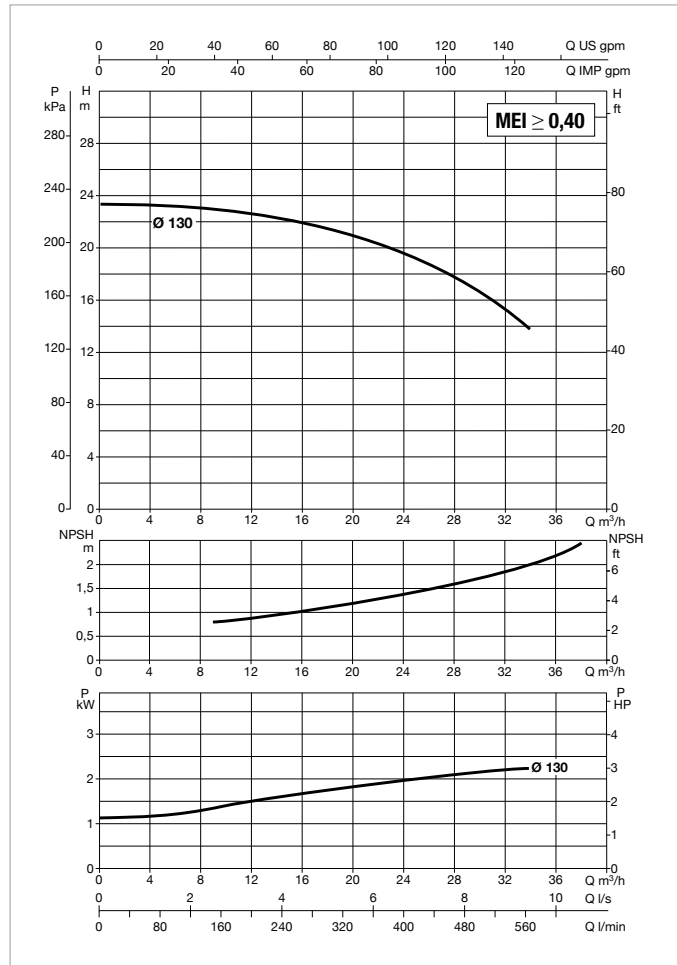
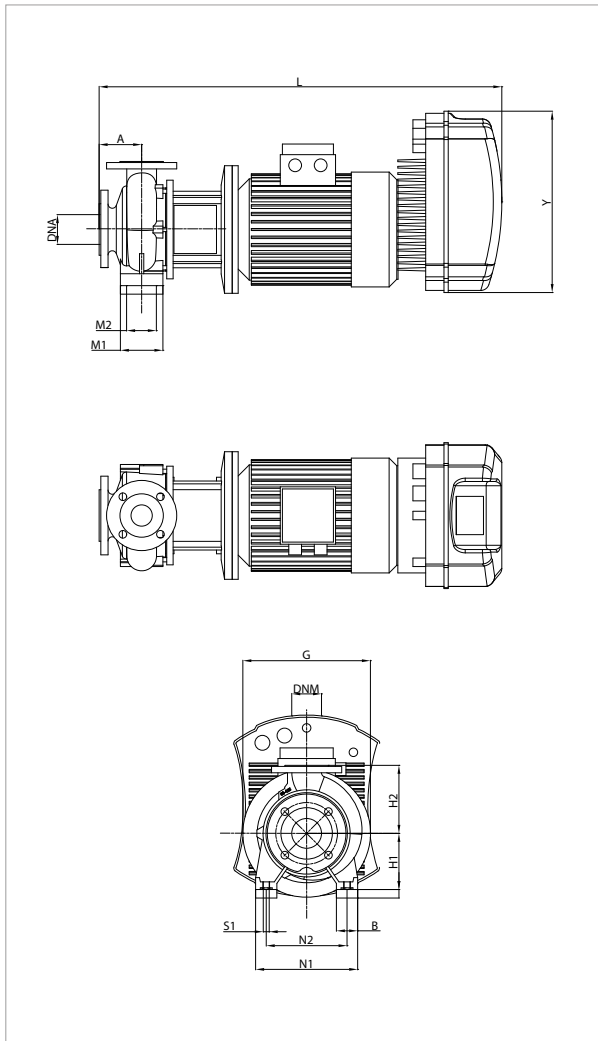

See hydraulic efficiency details on page 241.

The performance curves are based on kinematic viscosity values = 1 mm²/s and density equal to 1000 kg/m³. Curve tolerance according to ISO 9906.

MODEL	MCE MODEL	POWER INPUT 50 Hz	P2 NOMINAL		In A
			kW	HP	
NKP-GE 32-125/130/A/BAQE/2.2/2 M MCE22/C	MCE22/C	1 x 230 -V	2,20	3,0	24,3
NKP-GE 32-125/130/A/BAQE/2.2/2 T MCE30/C	MCE30/C	3 x 400 -V	2,20	3,0	t.b.d.

MODEL	A	B	G	H1	H2	L	M1	M2	N1	N2	S1	X	Y	DNA	DNM	PACKING DIMENSIONS			WEIGHT kg
																L/A	L/B	H	
NKP-GE 32-125/130/A/BAQE/2.2/2 M MCE22/C	80	50	234	112	140	698	100	70	190	140	M10	100	262	50	32	800	400	400	58
NKP-GE 32-125/130/A/BAQE/2.2/2 T MCE30/C	80	50	234	112	140	765	100	70	190	140	M10	100	353	50	32	800	400	400	60,6

NKP-GE 32-125 - STANDARDISED MONOBLOC CENTRIFUGAL ELECTRIC PUMPS WITH INVERTER FOR PRESSURISATION SYSTEMS



Pumped liquid temperature range: from -10 °C to +80 °C (MCE/P) - Maximum ambient temperature: +40 °C

≈ 2900 1/min

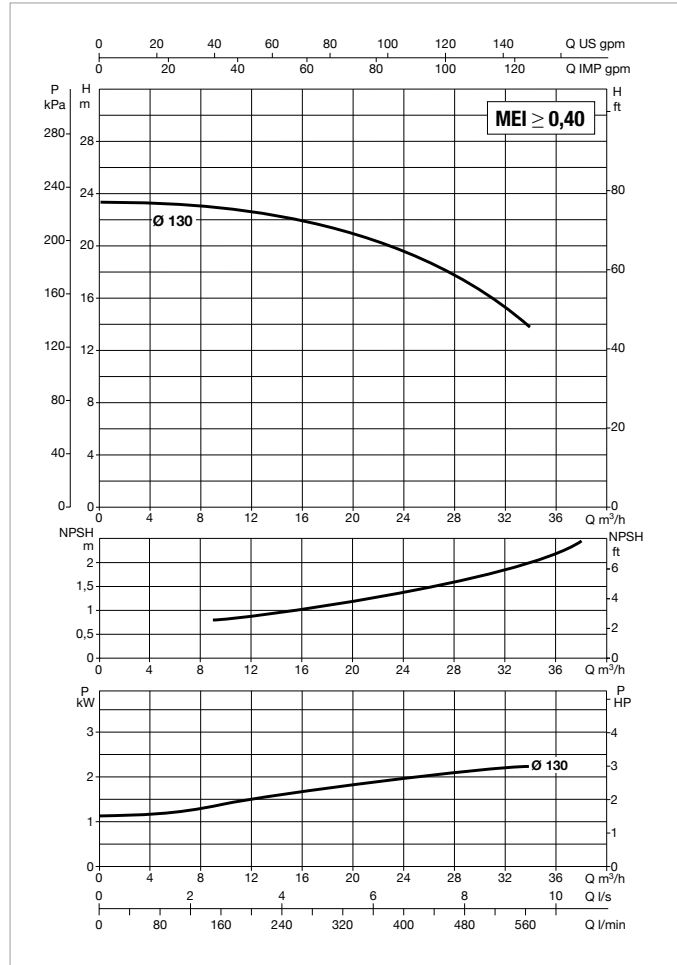
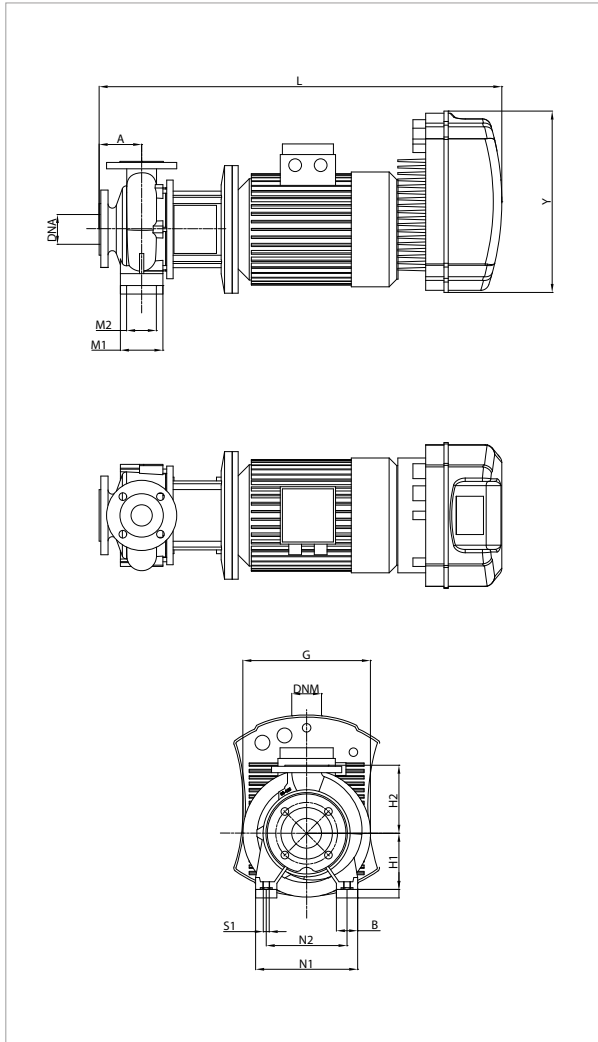

See hydraulic efficiency details on page 241.

The performance curves are based on kinematic viscosity values = 1 mm²/s and density equal to 1000 kg/m³. Curve tolerance according to ISO 9906.

MODEL	MCE MODEL	POWER INPUT 50 Hz	P2 NOMINAL		In A
			kW	HP	
NKP-GE 32-125/130/A/BAQE/2.2/2 M MCE22/P	MCE22/P	1 x 230 -V	2,2	3,0	18,55

MODEL	A	B	G	H1	H2	L	M1	M2	N1	N2	S1	X	Y	DNA	DNM	PACKING DIMENSIONS			WEIGHT kg
																L/A	L/B	H	
NKP-GE 32-125/130/A/BAQE/2.2/2 M MCE22/P	80	50	234	112	140	698	100	70	190	140	M10	100	262	50	32	800	400	400	58

NKP-GE 32-125 - STANDARDISED MONOBLOC CENTRIFUGAL ELECTRIC PUMPS

WITH INVERTER FOR CIRCULATION OR PRESSURISATION SYSTEMS

MCE-C

MCE-P

Pumped liquid temperature range: from -10 °C to +140 °C (MCE/C) - from -10 °C to +80 °C (MCE/P) - Maximum ambient temperature: +40 °C
 ≈ 2900 1/min

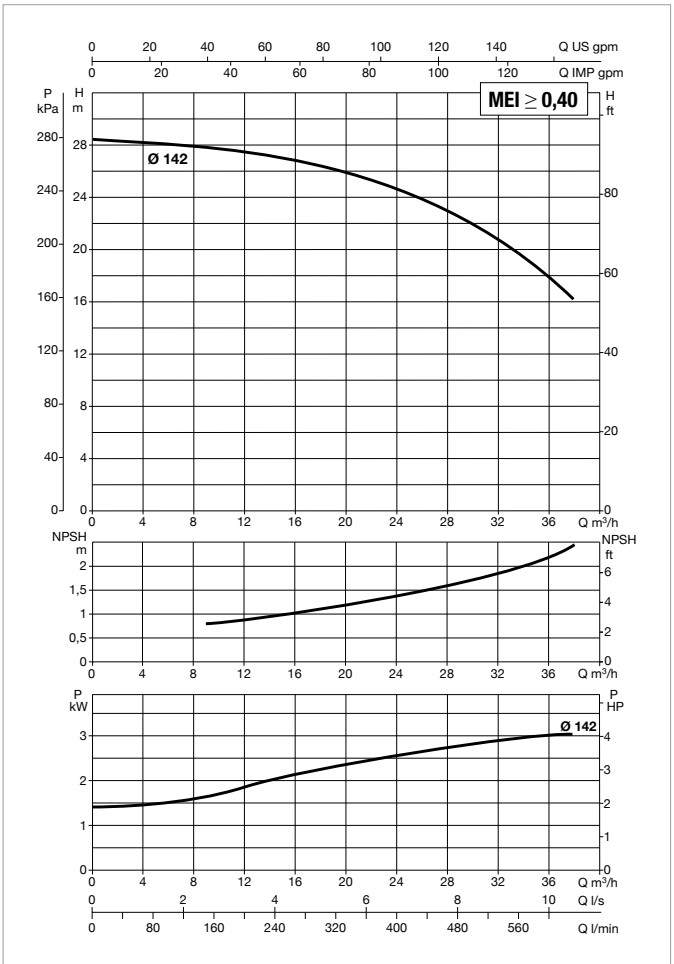
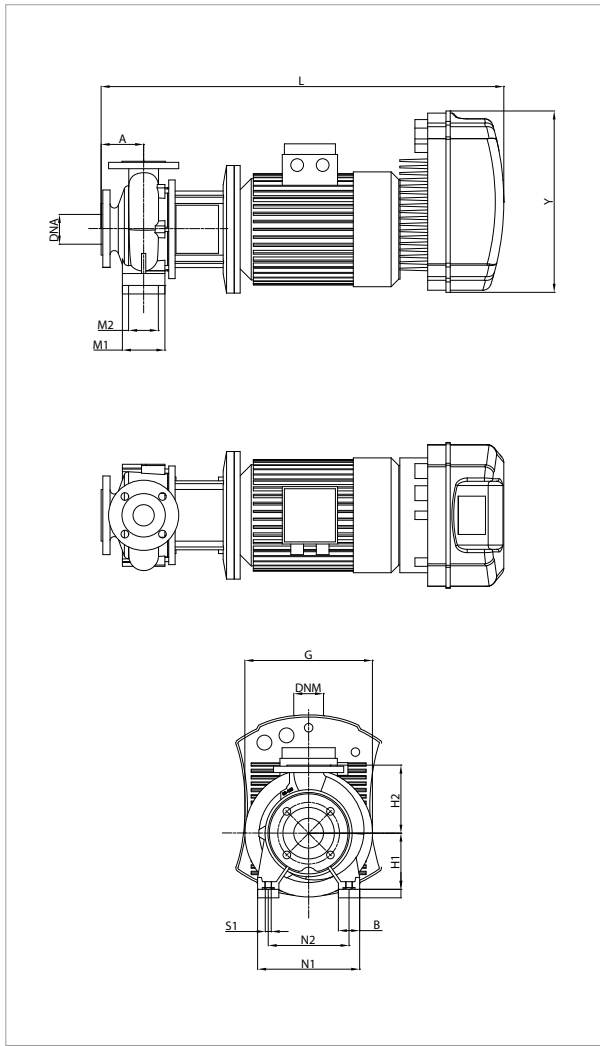

See hydraulic efficiency details on page 241.
 The performance curves are based on kinematic viscosity values = 1 mm²/s and density equal to 1000 kg/m³. Curve tolerance according to ISO 9906.

MODEL	MCE MODEL	POWER INPUT 50 Hz	P2 NOMINAL		In A
			kW	HP	
NKP-GE 32-125/142/A/ BAQE/3/2 T MCE30/C-P	MCE30/C - MCE30/P	3 x 400 ~V	3,00	4,00	7,0

MODEL	A	B	G	H1	H2	L	M1	M2	N1	N2	S1	X	Y	DNA	DNM	PACKING DIMENSIONS			WEIGHT kg
																L/A	L/B	H	
NKP-GE 32-125/142/A/ BAQE/3/2 T MCE30/C-P	80	50	250	112	140	755	100	70	190	140	M10	100	353	50	32	800	400	400	76

NKP-GE 32-160.1 - STANDARDISED MONOBLOC CENTRIFUGAL ELECTRIC PUMPS WITH INVERTER FOR PRESSURISATION SYSTEMS



Pumped liquid temperature range: from -10 °C to +80 °C (MCE/P) - Maximum ambient temperature: +40 °C

≈ 2900 1/min

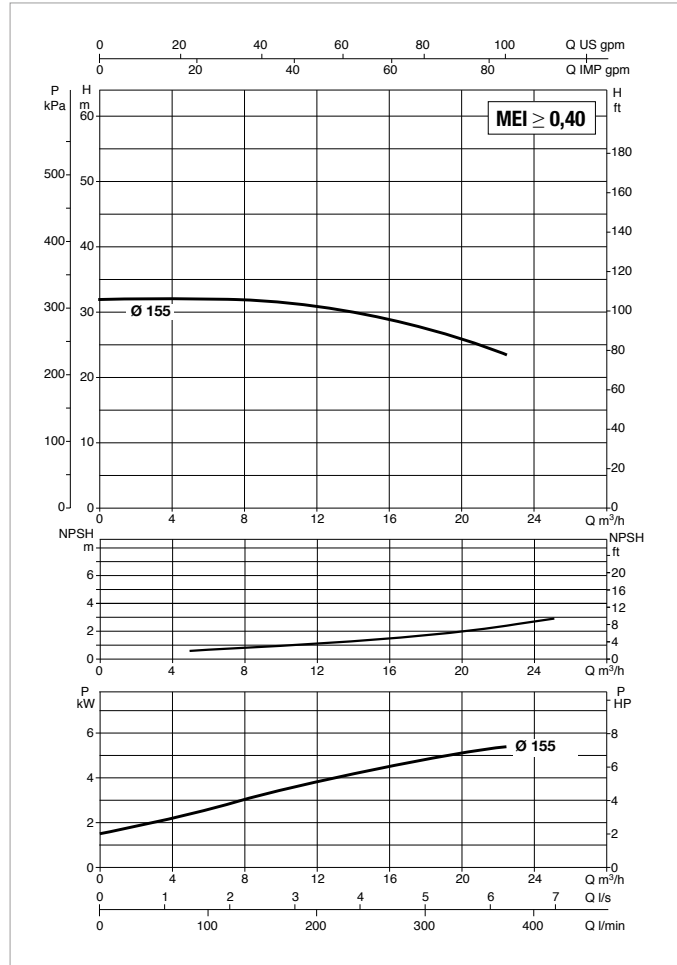
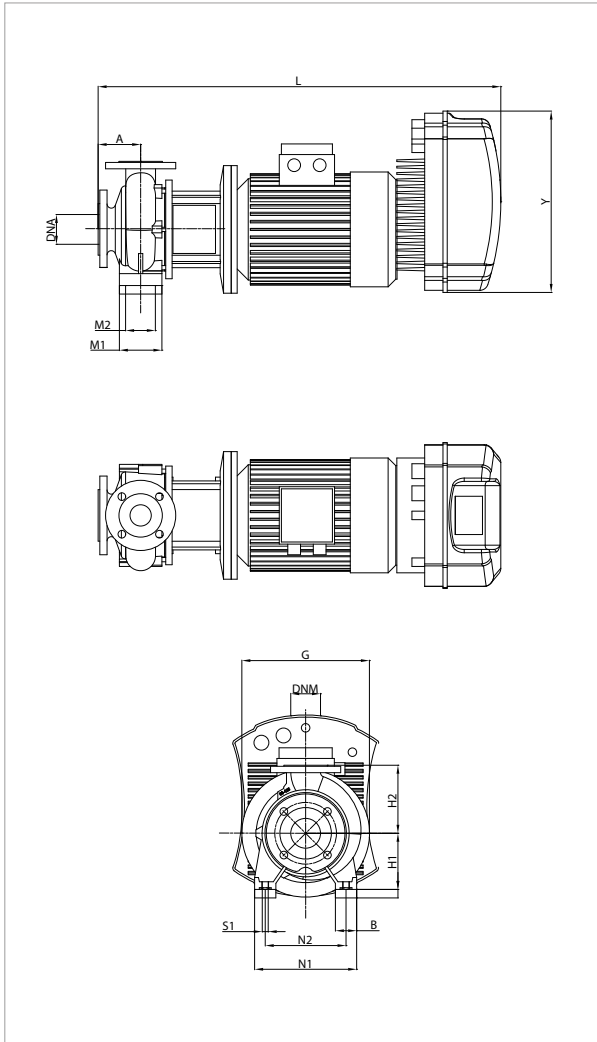

See hydraulic efficiency details on page 241.

The performance curves are based on kinematic viscosity values = 1 mm²/s and density equal to 1000 kg/m³. Curve tolerance according to ISO 9906.

MODEL	MCE MODEL	POWER INPUT 50 Hz	P2 NOMINAL		In A
			kW	HP	
NKP-GE 32-160.1 155/A/BAQE/2.2/2 MCE22/P	MCE22/P	1 x 230 ~V	2,2	3,0	19,42

MODEL	A	B	G	H1	H2	L	M1	M2	N1	N2	S1	X	Y	DNA	DNM	PACKING DIMENSIONS			WEIGHT kg
																L/A	L/B	H	
NKP-GE 32-160.1 155/A/BAQE/2.2/2 MCE22/P	80	50	245	132	160	721	100	70	240	190	M10	100	262	50	32	826	430	426	53

NKP-GE 32-160.1 - STANDARDISED MONOBLOC CENTRIFUGAL ELECTRIC PUMPS WITH INVERTER FOR CIRCULATION OR PRESSURISATION SYSTEMS

MCE-C

MCE-P

Pumped liquid temperature range: from -10 °C to +140 °C (MCE/C) - from -10 °C to +80 °C (MCE/P) - Maximum ambient temperature: +40 °C
 ≈ 2900 1/min

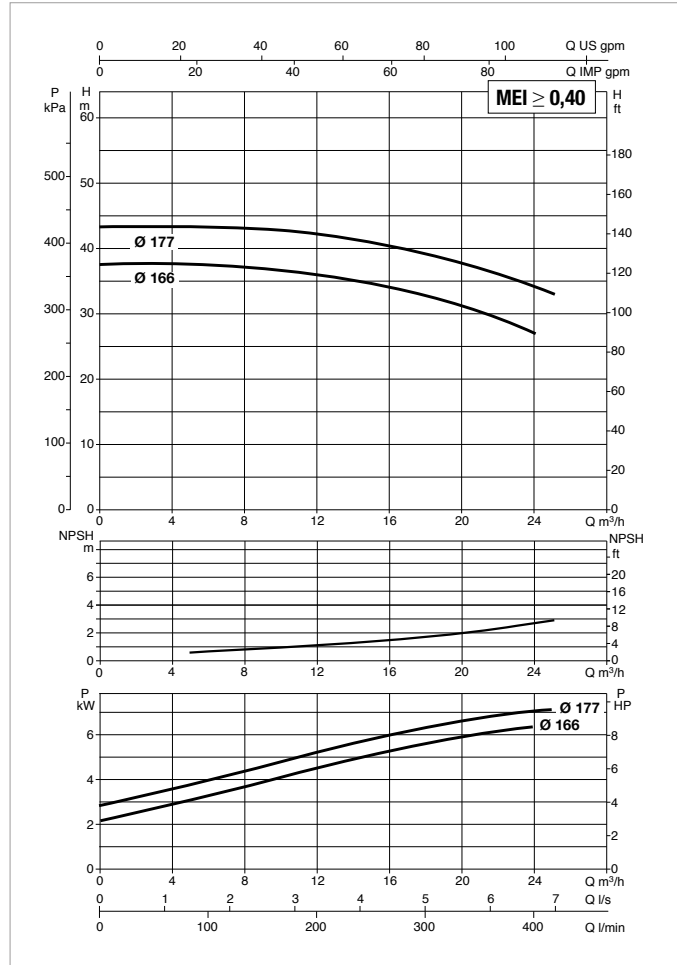
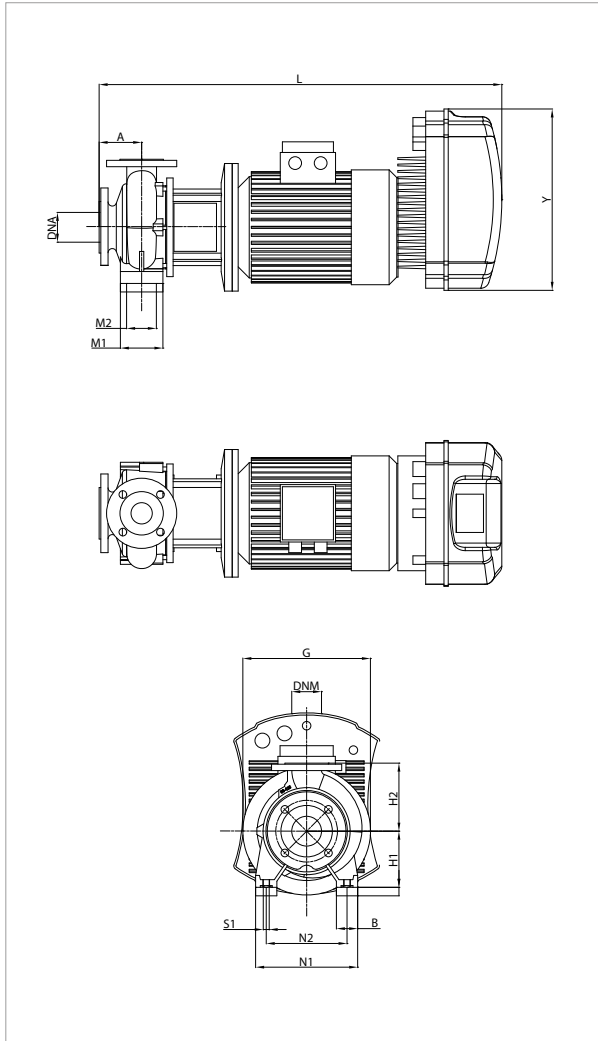

See hydraulic efficiency details on page 241.
 The performance curves are based on kinematic viscosity values = 1 mm²/s and density equal to 1000 kg/m³. Curve tolerance according to ISO 9906.

MODEL	MCE MODEL	POWER INPUT 50 Hz	P2 NOMINAL		In A
			kW	HP	
NKP-GE 32-160.1/166/A/BAQE/3/2 T MCE30/C-P	MCE30/C - MCE30/P	3 x 400 ~V	3,00	4,00	6,7
NKP-GE 32-160.1/177/A/BAQE/4/2 T MCE55/C-P	MCE55/C - MCE55/P	3 x 400 ~V	4,00	5,50	8,5

MODEL	A	B	G	H1	H2	L	M1	M2	N1	N2	S1	X	Y	DNA	DNM	PACKING DIMENSIONS			WEIGHT kg
																L/A	L/B	H	
NKP-GE 32-160.1/166/A/BAQE/3/2 T MCE30/C-P	80	50	250	132	160	755	100	70	240	190	M10	100	353	50	32	800	400	400	70
NKP-GE 32-160.1/177/A/BAQE/4/2 T MCE55/C-P	80	50	250	132	160	755	100	70	240	190	M10	100	353	50	32	800	400	400	91

NKP-GE 32-160 - STANDARDISED MONOBLOC CENTRIFUGAL ELECTRIC PUMPS

WITH INVERTER FOR CIRCULATION OR PRESSURISATION SYSTEMS



Pumped liquid temperature range: from -10 °C to +140 °C (MCE/C) - from -10 °C to +80 °C (MCE/P) - Maximum ambient temperature: +40 °C
 ≈ 2900 1/min

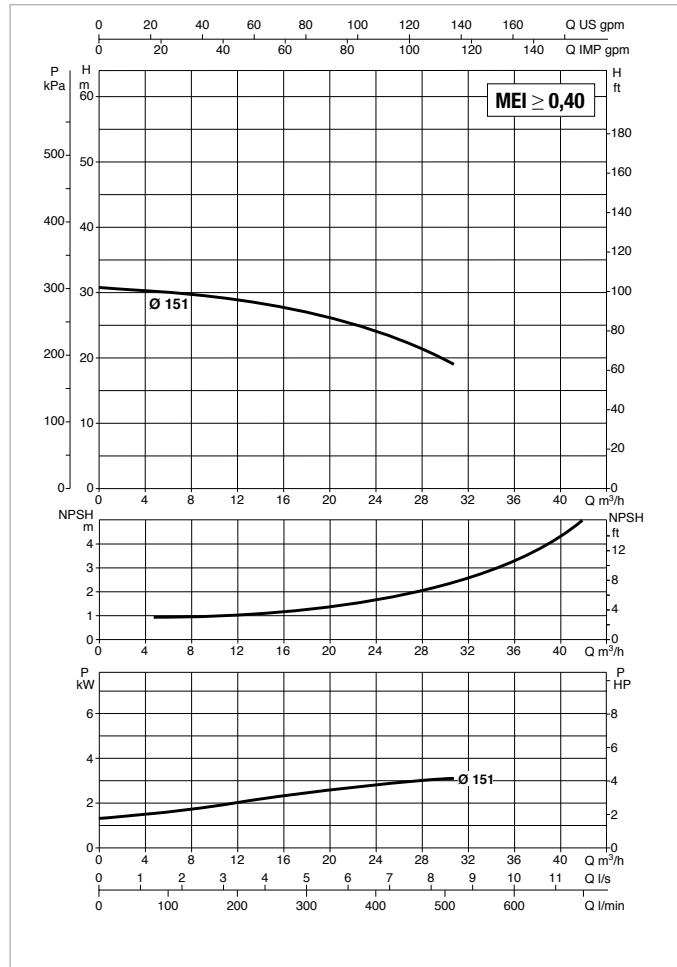
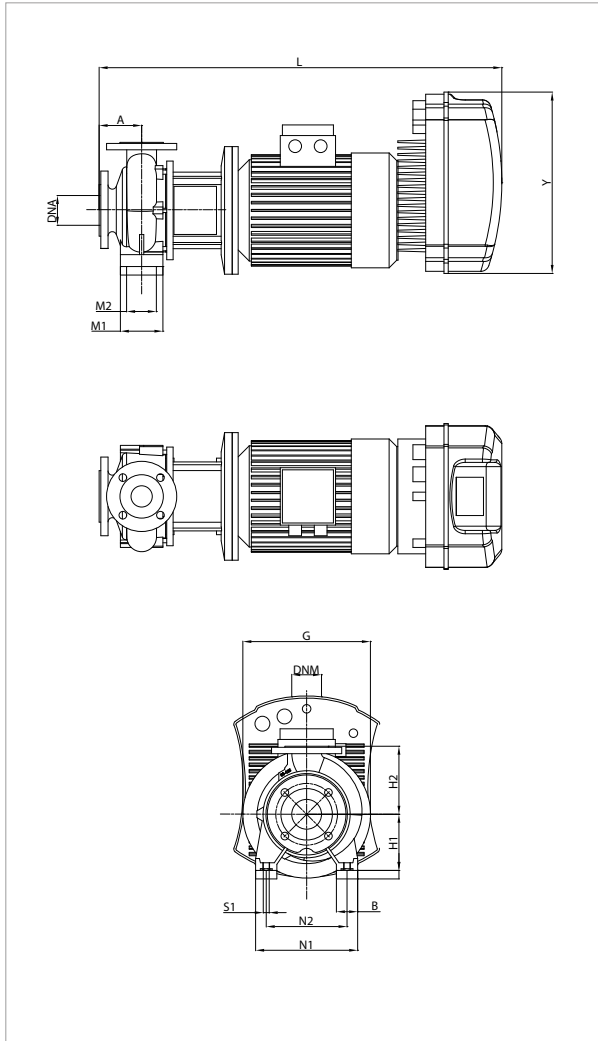

See hydraulic efficiency details on page 241.

The performance curves are based on kinematic viscosity values = 1 mm²/s and density equal to 1000 kg/m³. Curve tolerance according to ISO 9906.

MODEL	MCE MODEL	POWER INPUT 50 Hz	P2 NOMINAL		In A
			kW	HP	
NKP-GE 32-160/151/A/BAQE/3/2 T MCE30/C-P	MCE30/C - MCE30/P	3 x 400 -V	3,00	4,0	7,1

MODEL	A	B	G	H1	H2	L	M1	M2	N1	N2	S1	X	Y	DNA	DNM	PACKING DIMENSIONS			WEIGHT kg
																L/A	L/B	H	
NKP-GE 32-160/151/A/BAQE/3/2 T MCE30/C-P	80	50	250	132	160	755	100	70	240	190	M10	100	353	50	32	800	400	400	70

NKP-GE 32-160 - STANDARDISED MONOBLOC CENTRIFUGAL ELECTRIC PUMPS WITH INVERTER FOR PRESSURISATION SYSTEMS



Pumped liquid temperature range: from -10 °C to +80 °C (MCE/P) - Maximum ambient temperature: +40 °C

≈ 2900 1/min

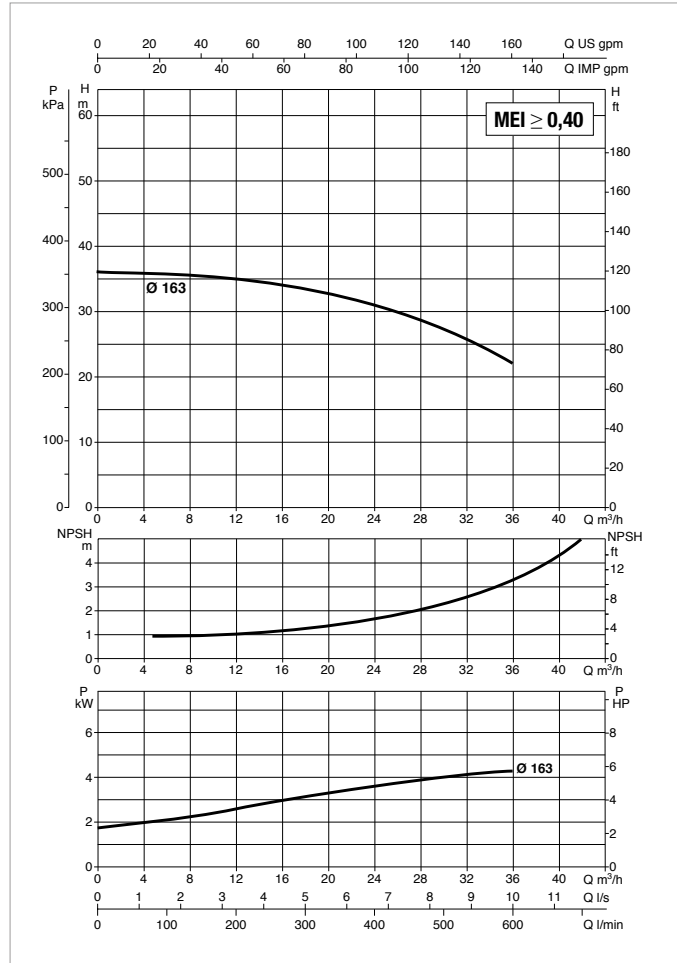
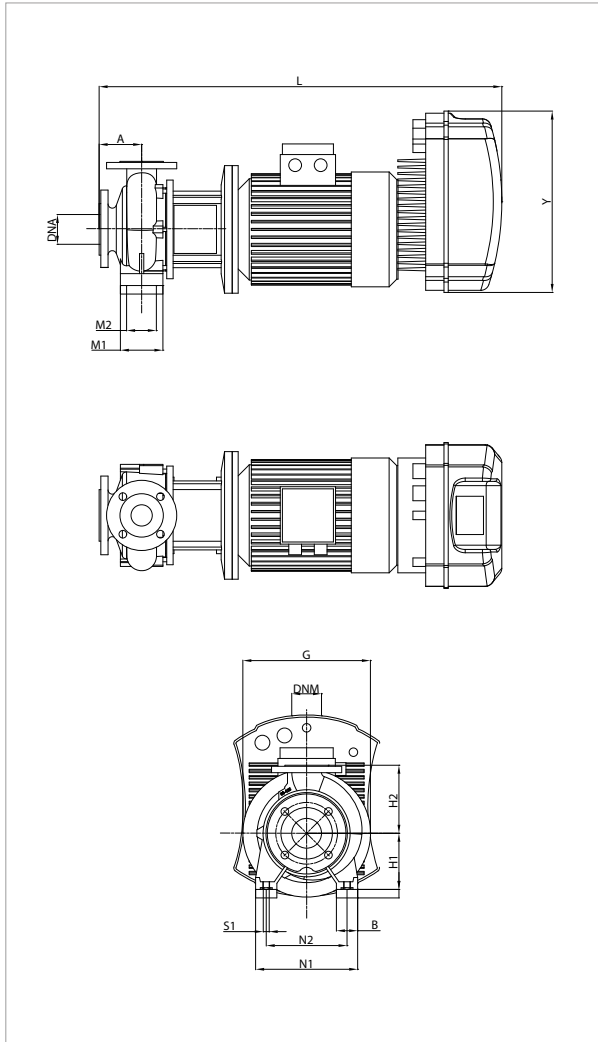

See hydraulic efficiency details on page 241.

The performance curves are based on kinematic viscosity values = 1 mm²/s and density equal to 1000 kg/m³. Curve tolerance according to ISO 9906.

MODEL	MCE MODEL	POWER INPUT 50 Hz	P2 NOMINAL		In A
			kW	HP	
NKP-GE 32-160/163/A/BAQE /4/2 MCE55/P	MCE55/P	3 x 400 -V	4,0	5,5	9,83

MODELLO	A	B	G	H1	H2	L	M1	M2	N1	N2	S1	X	Y	DNA	DNM	PACKING DIMENSIONS			WEIGHT kg
																L/A	L/B	H	
NKP-GE 32-160/163/A/BAQE /4/2 MCE55/P	80	50	267	132	160	794	100	70	240	190	M10	100	353	50	32	826	430	426	92

NKP-GE 32-160 - STANDARDISED MONOBLOC CENTRIFUGAL ELECTRIC PUMPS

WITH INVERTER FOR CIRCULATION OR PRESSURISATION SYSTEMS



Pumped liquid temperature range: from -10 °C to +140 °C (MCE/C) - from -10 °C to +80 °C (MCE/P) - Maximum ambient temperature: +40 °C
 ≅ 2900 1/min

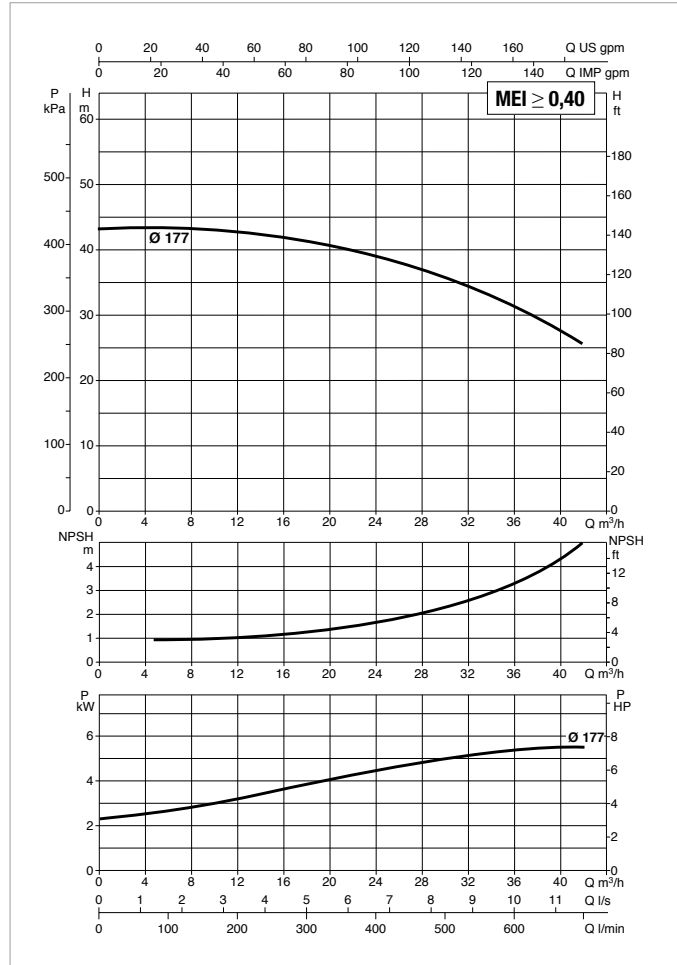
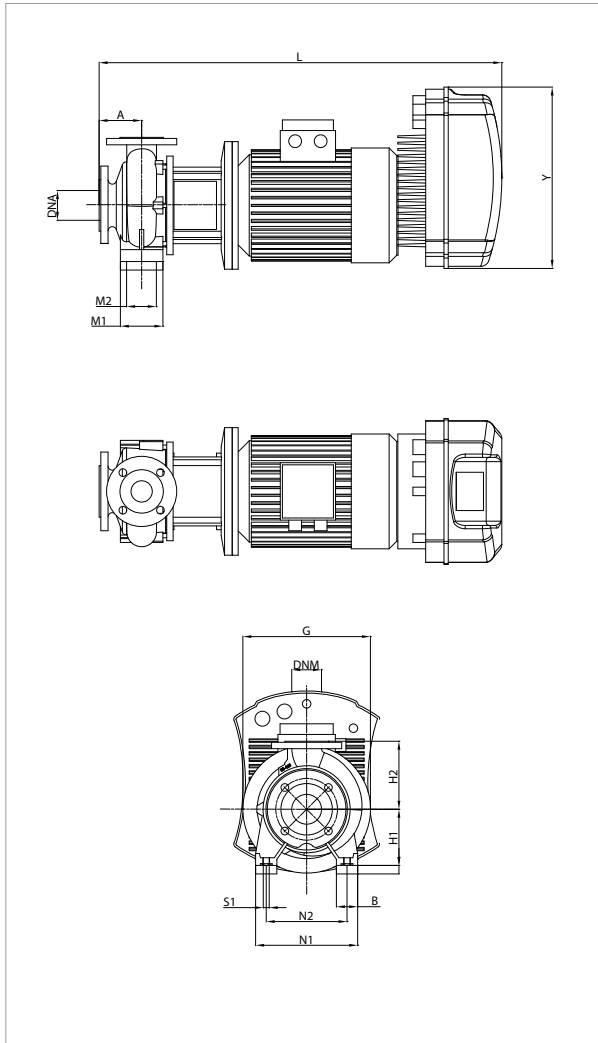

See hydraulic efficiency details on page 241.

The performance curves are based on kinematic viscosity values = 1 mm²/s and density equal to 1000 kg/m³. Curve tolerance according to ISO 9906.

MODEL	MCE MODEL	POWER INPUT 50 Hz	P2 NOMINAL		In A
			kW	HP	
NKP-GE 32-160/177/A/BAQE/5,5/2 T MCE55/C-P	MCE55/C - MCE55/P	3 x 400 ~V	5,50	7,5	12,7

MODEL	A	B	G	H1	H2	L	M1	M2	N1	N2	S1	X	Y	DNA	DNM	PACKING DIMENSIONS			WEIGHT kg
																L/A	L/B	H	
NKP-GE 32-160/177/A/BAQE/5,5/2 T MCE55/C-P	80	50	300	132	160	883	100	70	240	190	M10	100	353	50	32	1100	550	620	114

NKP-GE 32-200.1 - STANDARDISED MONOBLOC CENTRIFUGAL ELECTRIC PUMPS WITH INVERTER FOR PRESSURISATION SYSTEMS



Pumped liquid temperature range: from -10 °C to +80 °C (MCE/P) - Maximum ambient temperature: +40 °C

≈ 2900 1/min

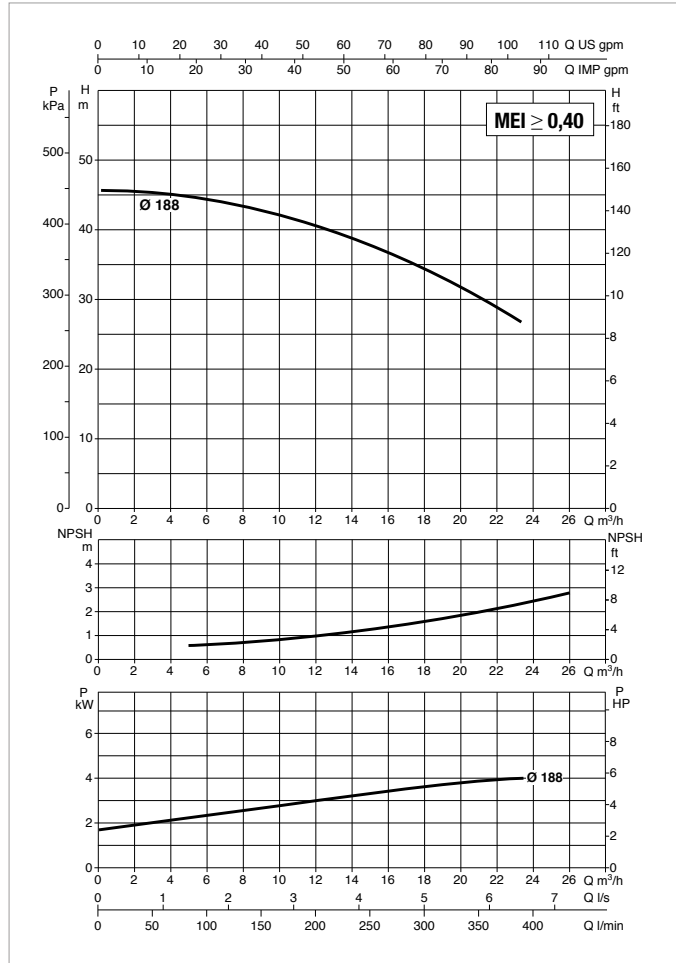
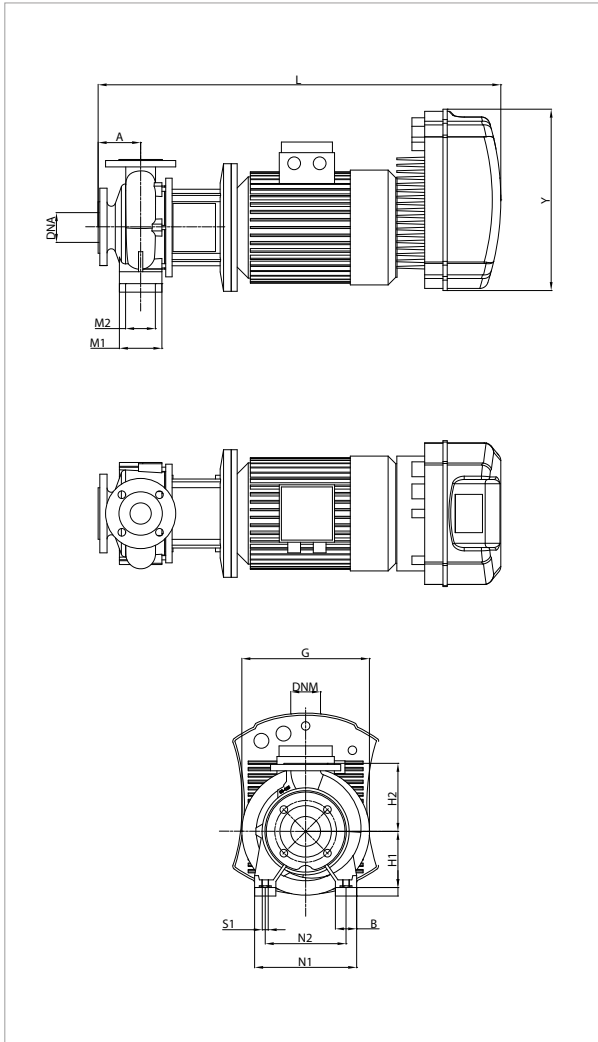

See hydraulic efficiency details on page 241.

The performance curves are based on kinematic viscosity values = 1 mm²/s and density equal to 1000 kg/m³. Curve tolerance according to ISO 9906.

MODEL	MCE MODEL	POWER INPUT 50 Hz	P2 NOMINAL		In A
			kW	HP	
NKP-GE 32-200.1/188/A/BAQE/4/2 MCE55/P	MCE55/P	3 x 400 -V	5,5	7,5	9,10

MODEL	A	B	G	H1	H2	L	M1	M2	N1	N2	S1	X	Y	DNA	DNM	PACKING DIMENSIONS			WEIGHT kg
																L/A	L/B	H	
NKP-GE 32-200.1/188/A/BAQE/4/2 MCE55/P	80	50	279	160	180	794	100	70	240	190	M10	100	353	50	32	826	430	426	92

NKP-GE 32-200.1 - STANDARDISED MONOBLOC CENTRIFUGAL ELECTRIC PUMPS

WITH INVERTER FOR CIRCULATION OR PRESSURISATION SYSTEMS



Pumped liquid temperature range: from -10 °C to +140 °C (MCE/C) - from -10 °C to +80 °C (MCE/P) - Maximum ambient temperature: +40 °C
 ≈ 2900 1/min

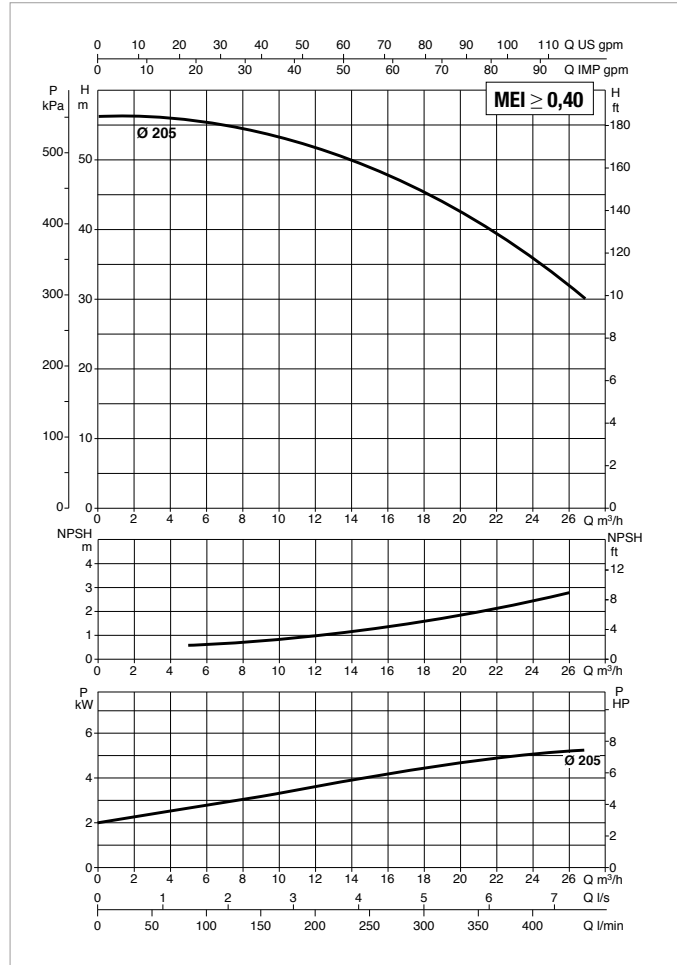
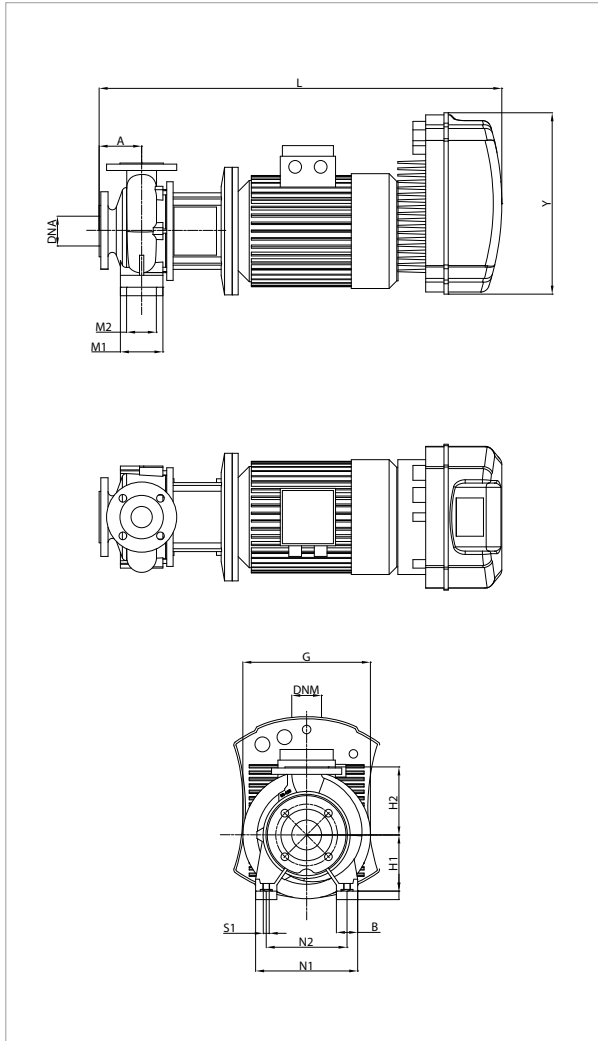

See hydraulic efficiency details on page 241.

The performance curves are based on kinematic viscosity values = 1 mm²/s and density equal to 1000 kg/m³. Curve tolerance according to ISO 9906.

MODEL	MCE MODEL	POWER INPUT 50 Hz	P2 NOMINAL		In A
			kW	HP	
NKP-GE 32-200.1/205/A/BAQE/5,5/2 T MCE55/C-P	MCE55/C - MCE55/P	3 x 400 -V	5,50	7,5	11,4

MODEL	A	B	G	H1	H2	L	M1	M2	N1	N2	S1	X	Y	DNA	DNM	PACKING DIMENSIONS			WEIGHT kg
																L/A	L/B	H	
NKP-GE 32-200.1/205/A/BAQE/5,5/2 T MCE55/C-P	80	50	300	160	180	883	100	70	240	190	M10	100	353	50	32	1100	550	620	114

NKP-GE 32-200 - STANDARDISED MONOBLOC CENTRIFUGAL ELECTRIC PUMPS

WITH INVERTER FOR CIRCULATION OR PRESSURISATION SYSTEMS



Pumped liquid temperature range: from -10 °C to +140 °C (MCE/C) - from -10 °C to +80 °C (MCE/P) - Maximum ambient temperature: +40 °C
 ≈ 2900 1/min

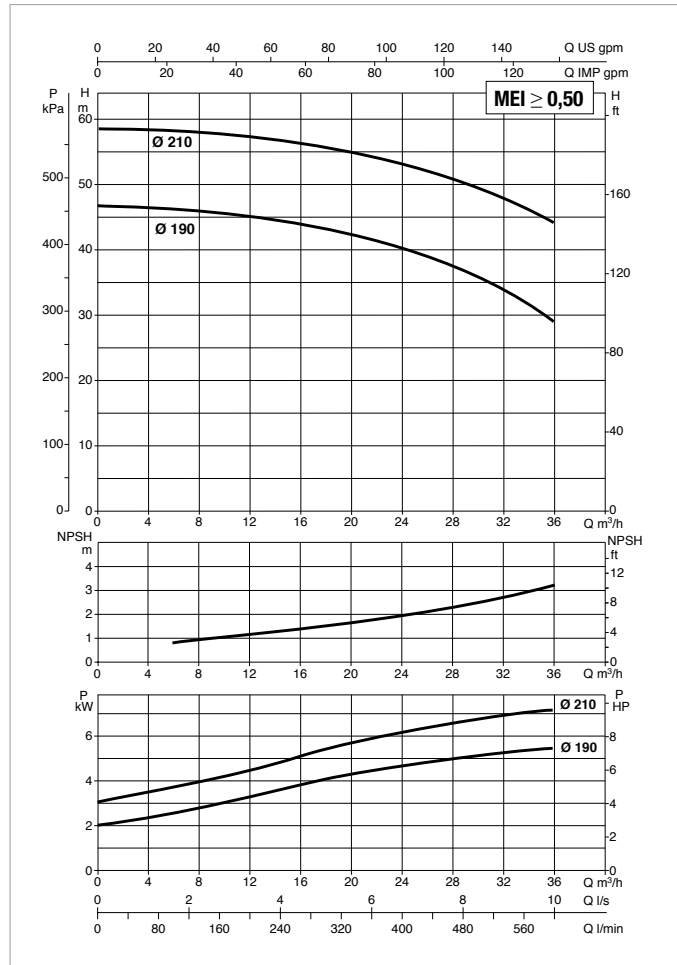
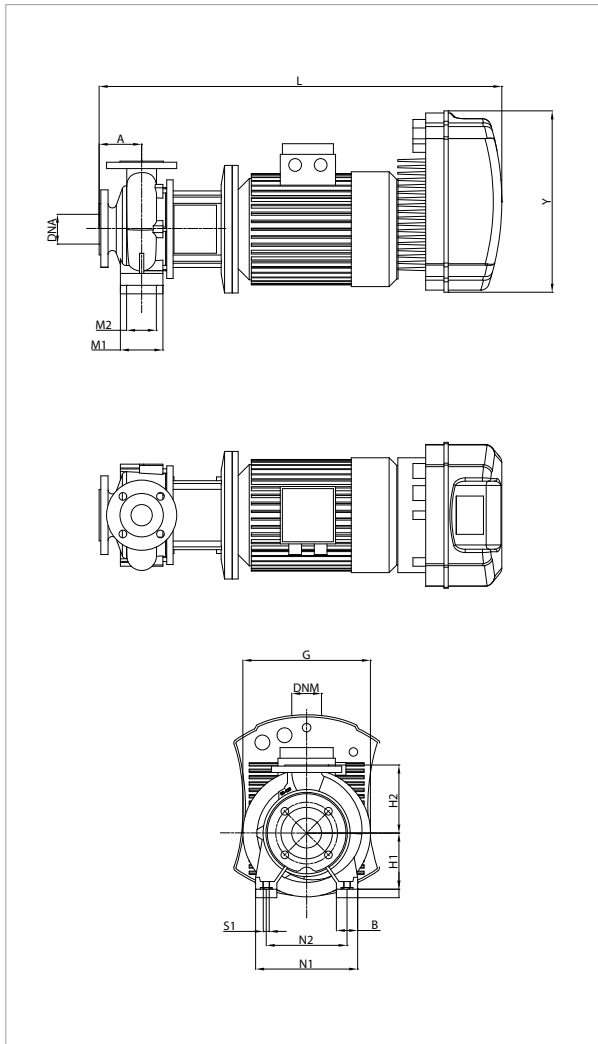

See hydraulic efficiency details on page 241.
 The performance curves are based on kinematic viscosity values = 1 mm²/s and density equal to 1000 kg/m³. Curve tolerance according to ISO 9906.

MODEL	MCE MODEL	POWER INPUT 50 Hz	P2 NOMINAL		In A
			kW	HP	
NKP-GE 32-200/190/A/BAQE/5.5/2 T MCE55/C-P	MCE55/C - MCE55/P	3 x 400 ~V	5,50	7,5	12,3
NKP-GE 32-200/210/A/BAQE/7.5/2 T MCE110/C-P	MCE110/C - MCE110/P	3 x 400 ~V	7,50	10,0	17,1

MODEL	A	B	G	H1	H2	L	M1	M2	N1	N2	S1	X	Y	DNA	DNM	PACKING DIMENSIONS			WEIGHT kg
																L/A	L/B	H	
NKP-GE 32-200/190/A/BAQE/5.5/2 T MCE55/C-P	80	50	300	160	180	883	100	70	240	190	M10	100	353	50	32	1100	550	620	126
NKP-GE 32-200/210/A/BAQE/7.5/2 T MCE110/C-P	80	50	300	160	180	933	100	70	240	190	M10	100	426	50	32	1100	550	620	135

NKP-GE 40-125 - STANDARDISED MONOBLOC CENTRIFUGAL ELECTRIC PUMPS WITH INVERTER FOR CIRCULATION SYSTEMS



Pumped liquid temperature range: from -10 °C to +140 °C (MCE/C) - Maximum ambient temperature: +40 °C

≈ 2900 1/min

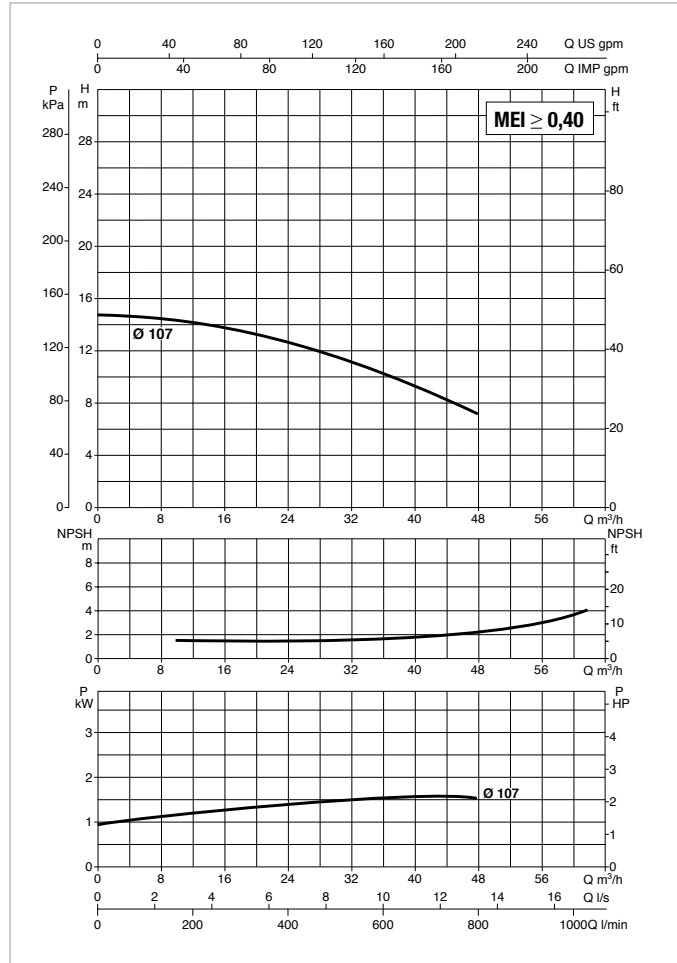
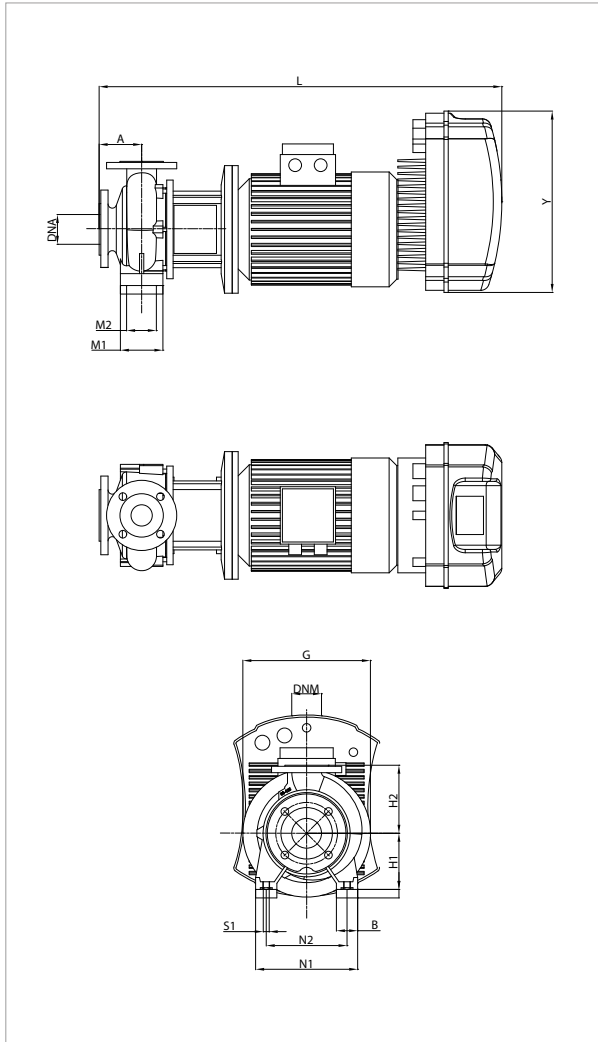

See hydraulic efficiency details on page 241.

The performance curves are based on kinematic viscosity values = 1 mm²/s and density equal to 1000 kg/m³. Curve tolerance according to ISO 9906.

MODEL	MCE MODEL	POWER INPUT 50 Hz	P2 NOMINAL		In A
			kW	HP	
NKP-GE 40-125/107/A/BAQE/1.5/2 M MCE15/C	MCE15/C	1 x 230 ~V	1,50	2,0	14,7
NKP-GE 40-125/107/A/BAQE/1.5/2 T MCE30/C	MCE30/C	3 x 400 ~V	1,50	2,0	t.b.d.

MODEL	A	B	G	H1	H2	L	M1	M2	N1	N2	S1	X	Y	DNA	DNM	PACKING DIMENSIONS			WEIGHT kg
																L/A	L/B	H	
NKP-GE 40-125/107/A/BAQE/1.5/2 M MCE15/C	80	50	234	112	140	673	100	70	210	160	M10	100	262	65	40	800	400	400	61
NKP-GE 40-125/107/A/BAQE/1.5/2 T MCE30/C	80	50	234	112	140	740	100	70	210	160	M10	100	353	65	40	800	400	400	63,6

NKP-GE 40-125 - STANDARDISED MONOBLOC CENTRIFUGAL ELECTRIC PUMPS WITH INVERTER FOR CIRCULATION SYSTEMS



Pumped liquid temperature range: from -10 °C to +140 °C (MCE/C) - Maximum ambient temperature: +40 °C

≈ 2900 1/min

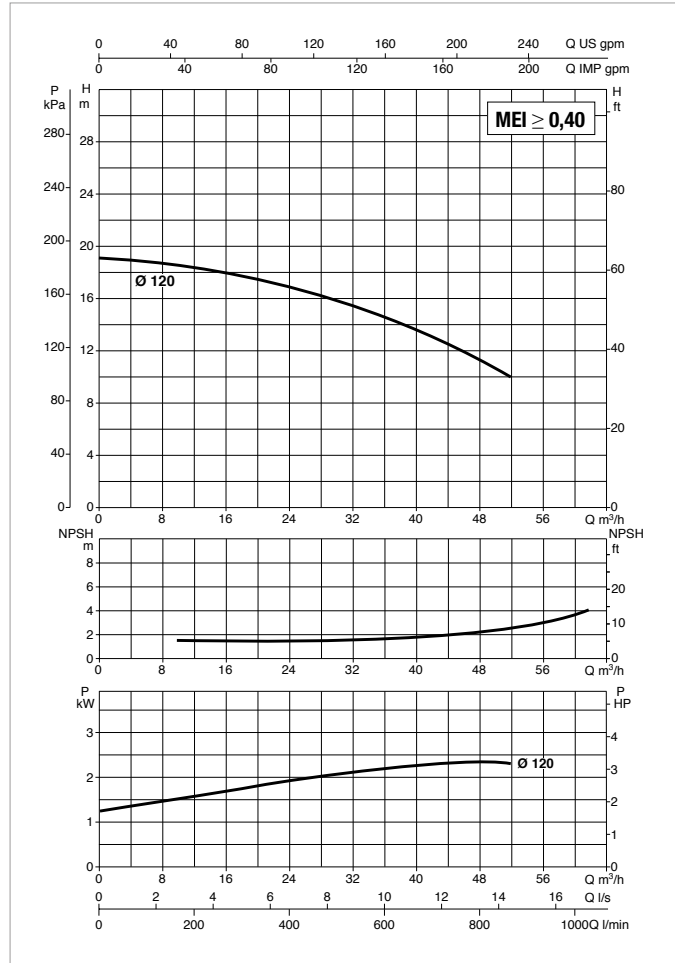
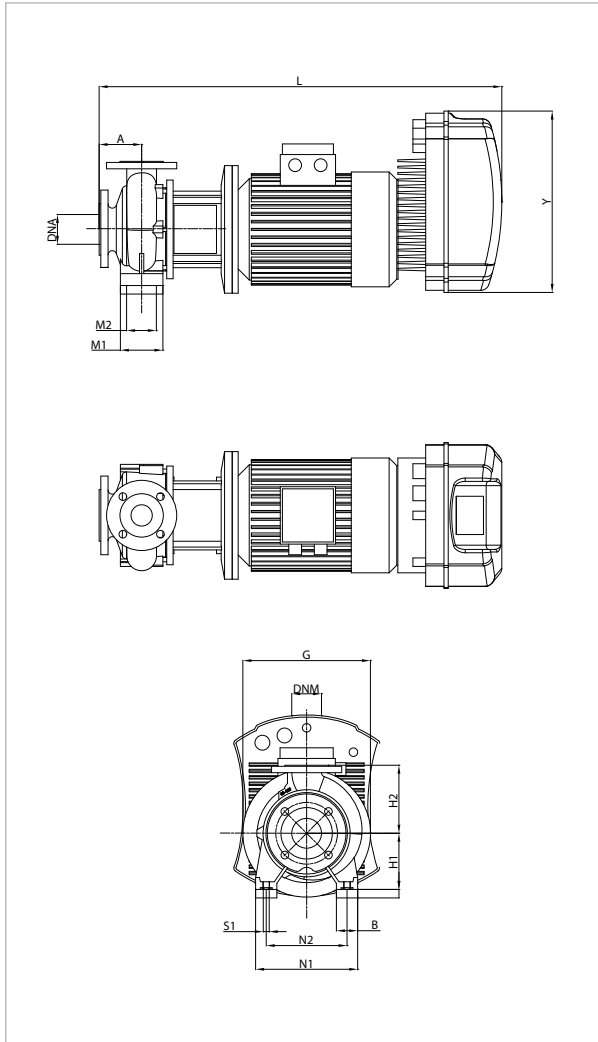

See hydraulic efficiency details on page 241.

The performance curves are based on kinematic viscosity values = 1 mm²/s and density equal to 1000 kg/m³. Curve tolerance according to ISO 9906.

MODEL	MCE MODEL	POWER INPUT 50 Hz	P2 NOMINAL		In A
			kW	HP	
NKP-GE 40-125/120/A/BAQE/2.2/2 M MCE22/C	MCE22/C	1 x 230 ~V	2,20	3,0	19,9
NKP-GE 40-125/120/A/BAQE/2.2/2 T MCE30/C	MCE30/C	3 x 400 ~V	2,20	3,0	t.b.d.

MODEL	A	B	G	H1	H2	L	M1	M2	N1	N2	S1	X	Y	DNA	DNM	PACKING DIMENSIONS			WEIGHT kg
																L/A	L/B	H	
NKP-GE 40-125/120/A/BAQE/2.2/2 M MCE22/C	80	50	234	112	140	698	100	70	210	160	M10	100	262	65	40	800	400	400	74
NKP-GE 40-125/120/A/BAQE/2.2/2 T MCE30/C	80	50	234	112	140	765	100	70	210	160	M10	100	353	65	40	800	400	400	76,6

NKP-GE 40-125 - STANDARDISED MONOBLOC CENTRIFUGAL ELECTRIC PUMPS WITH INVERTER FOR PRESSURISATION SYSTEMS



Pumped liquid temperature range: from -10 °C to +80 °C (MCE/P) - Maximum ambient temperature: +40 °C

≅ 2900 1/min

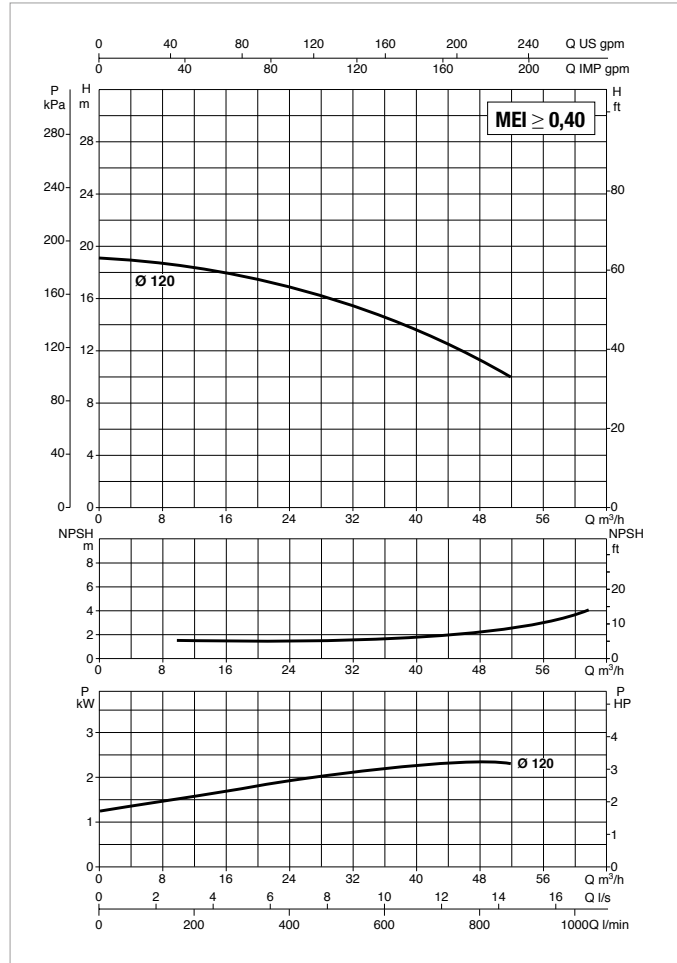
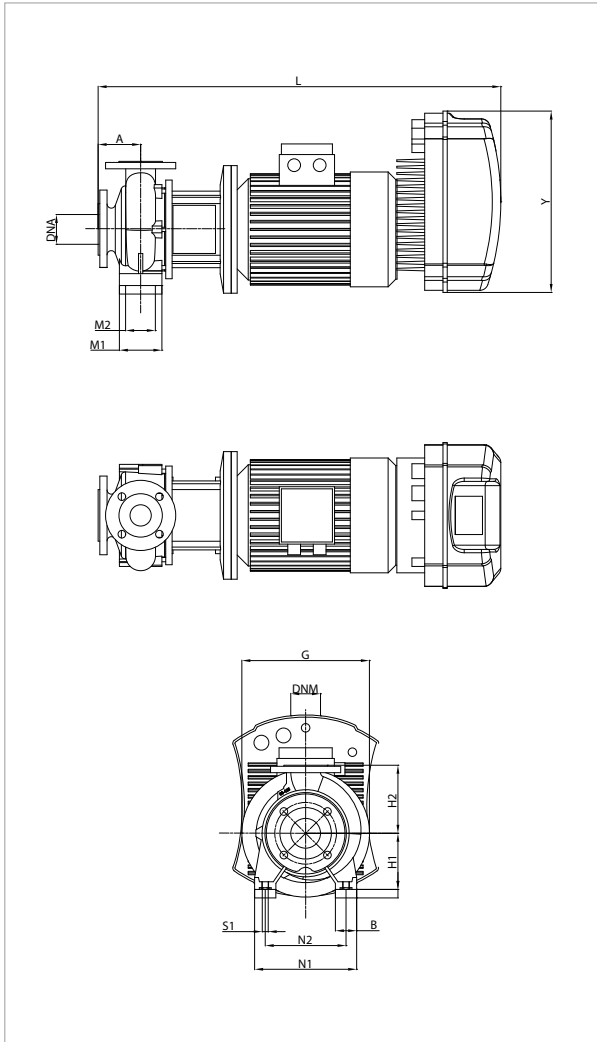

See hydraulic efficiency details on page 241.

The performance curves are based on kinematic viscosity values = 1 mm²/s and density equal to 1000 kg/m³. Curve tolerance according to ISO 9906.

MODEL	MCE MODEL	POWER INPUT 50 Hz	P2 NOMINAL		In A
			kW	HP	
NKP-GE 40-125/120/A/BAQE/2.2/2 M MCE22/P	MCE22/P	1 x 230 -V	2,2	3,0	20,62

MODEL	A	B	G	H1	H2	L	M1	M2	N1	N2	S1	X	Y	DNA	DNM	PACKING DIMENSIONS			WEIGHT kg
																L/A	L/B	H	
NKP-GE 40-125/120/A/BAQE/2.2/2 M MCE22/P	80	50	234	112	140	721	100	70	210	160	M10	100	262	65	40	826	430	426	74

NKP-GE 40-125 - STANDARDISED MONOBLOC CENTRIFUGAL ELECTRIC PUMPS

WITH INVERTER FOR CIRCULATION OR PRESSURISATION SYSTEMS



Pumped liquid temperature range: from -10 °C to +140 °C (MCE/C) - from -10 °C to +80 °C (MCE/P) - Maximum ambient temperature: +40 °C

≈ 2900 1/min

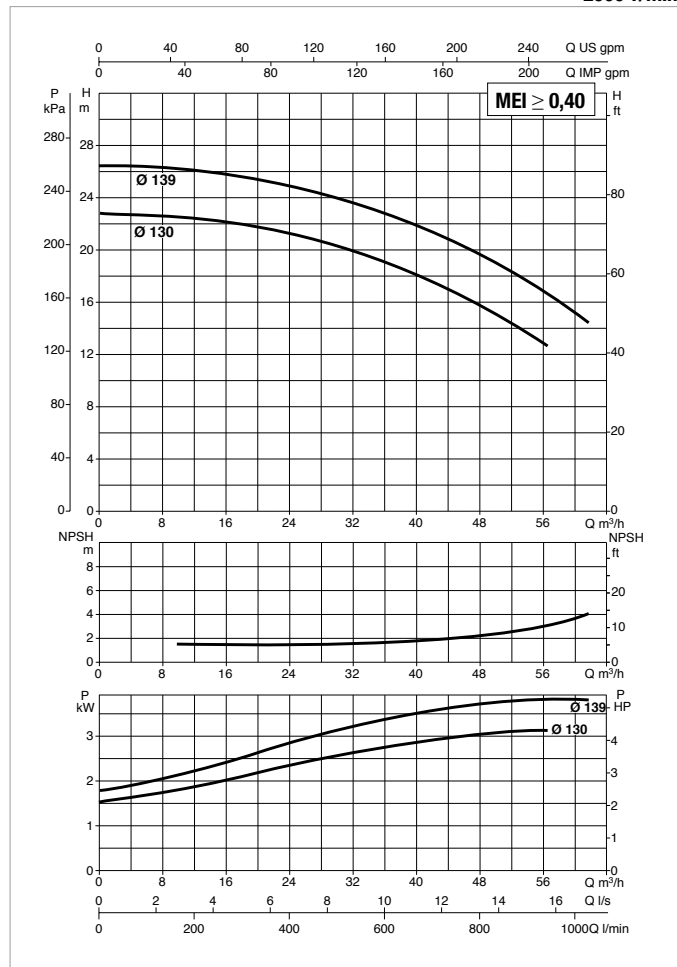
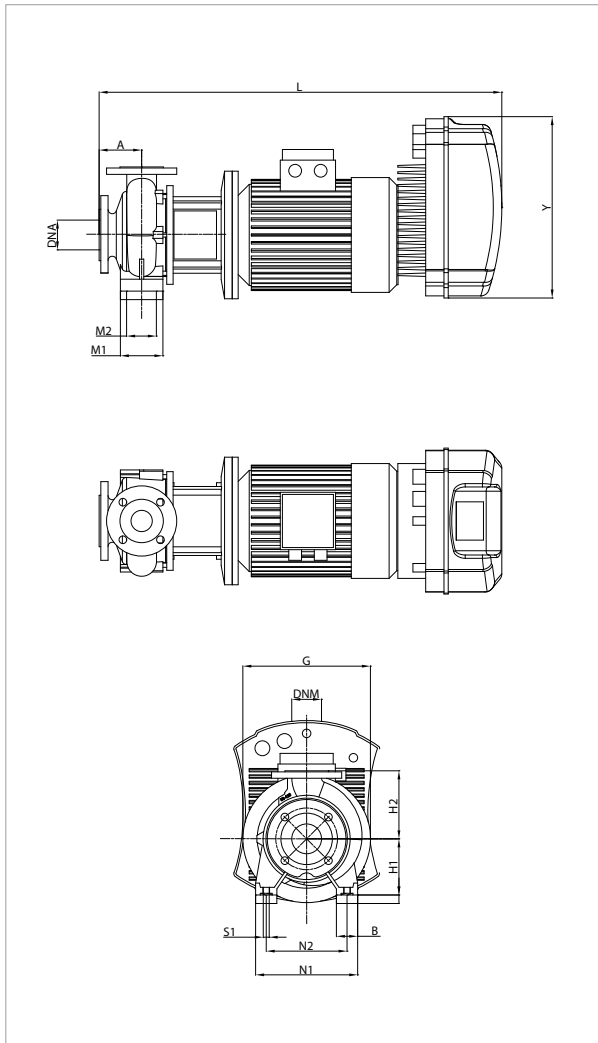

See hydraulic efficiency details on page 241.

The performance curves are based on kinematic viscosity values = 1 mm²/s and density equal to 1000 kg/m³. Curve tolerance according to ISO 9906.

MODEL	MCE MODEL	POWER INPUT 50 Hz	P2 NOMINAL		In A
			kW	HP	
NKP-GE 40-125/130/A/BAQE/3/2 T MCE30/C-P	MCE30/C - MCE30/P	3 x 400 ~V	3,00	4,0	7,2
NKP-GE 40-125/139/A/BAQE/4/2 T MCE55/C-P	MCE55/C - MCE55/P	3 x 400 ~V	4,00	5,5	9,6

MODEL	A	B	G	H1	H2	L	M1	M2	N1	N2	S1	X	Y	DNA	DNM	PACKING DIMENSIONS			WEIGHT kg
																L/A	L/B	H	
NKP-GE 40-125/130/A/BAQE/3/2 T MCE30/C-P	80	50	300	112	140	755	100	70	210	160	M10	100	353	65	40	800	400	400	85
NKP-GE 40-125/139/A/BAQE/4/2 T MCE55/C-P	80	50	300	112	140	755	100	70	210	160	M10	100	353	65	40	800	400	400	107

NKP-GE 40-160 - STANDARDISED MONOBLOC CENTRIFUGAL ELECTRIC PUMPS

WITH INVERTER FOR CIRCULATION OR PRESSURISATION SYSTEMS



Pumped liquid temperature range: from -10 °C to +140 °C (MCE/C) - from -10 °C to +80 °C (MCE/P) - Maximum ambient temperature: +40 °C

≈ 2900 1/min

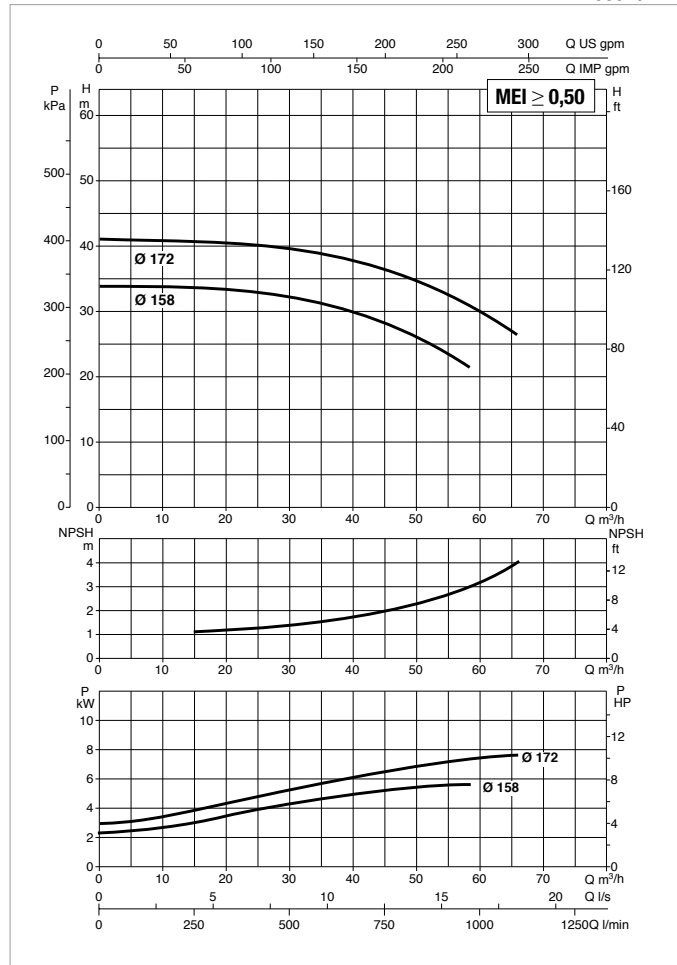
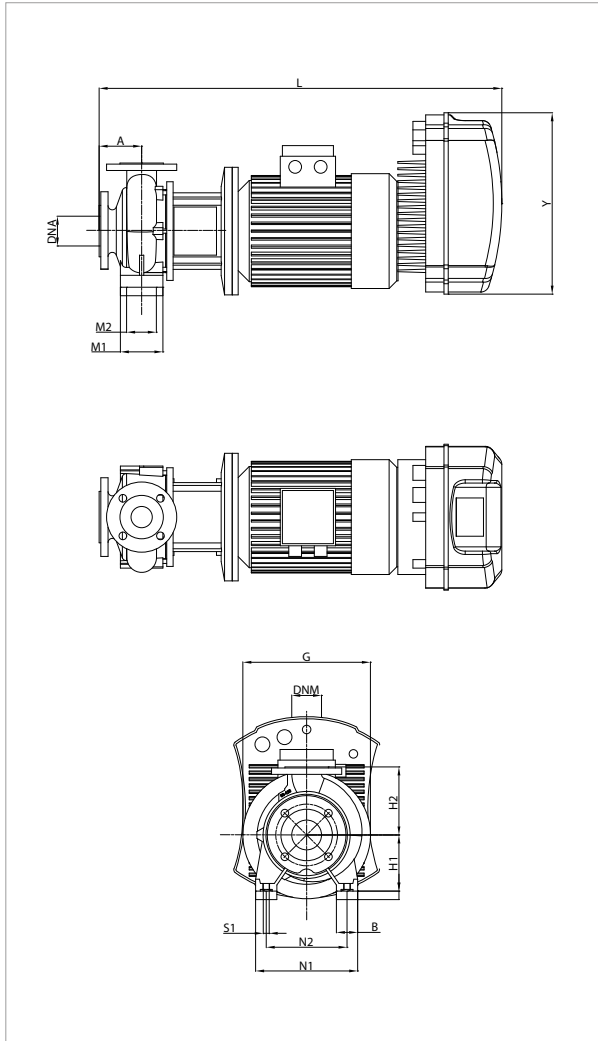

See hydraulic efficiency details on page 241.

The performance curves are based on kinematic viscosity values = 1 mm²/s and density equal to 1000 kg/m³. Curve tolerance according to ISO 9906.

MODEL	MCE MODEL	POWER INPUT 50 Hz	P2 NOMINAL		In A
			kW	HP	
NKP-GE 40-160/158/A/BAQE/5,5/2 T MCE55/C-P	MCE55/C - MCE55/P	3 x 400 ~V	5,50	7,5	12,4
NKP-GE 40-160/172/A/BAQE/7,5/2 T MCE110/C-P	MCE110/C - MCE110/P	3 x 400 ~V	7,50	10,0	17,1

MODEL	A	B	G	H1	H2	L	M1	M2	N1	N2	S1	X	Y	DNA	DNM	PACKING DIMENSIONS			WEIGHT kg
																L/A	L/B	H	
NKP-GE 40-160/158/A/BAQE/5,5/2 T MCE55/C-P	80	50	300	132	160	883	100	70	240	190	M10	100	353	65	40	1100	550	620	119
NKP-GE 40-160/172/A/BAQE/7,5/2 T MCE110/C-P	80	50	300	132	160	933	100	70	240	190	M10	100	426	65	40	1100	550	620	127

NKP-GE 40-200 - STANDARDISED MONOBLOC CENTRIFUGAL ELECTRIC PUMPS WITH INVERTER FOR CIRCULATION SYSTEMS



Pumped liquid temperature range: from -10 °C to +140 °C (MCE/C) - Maximum ambient temperature: +40 °C

≈ 2900 1/min

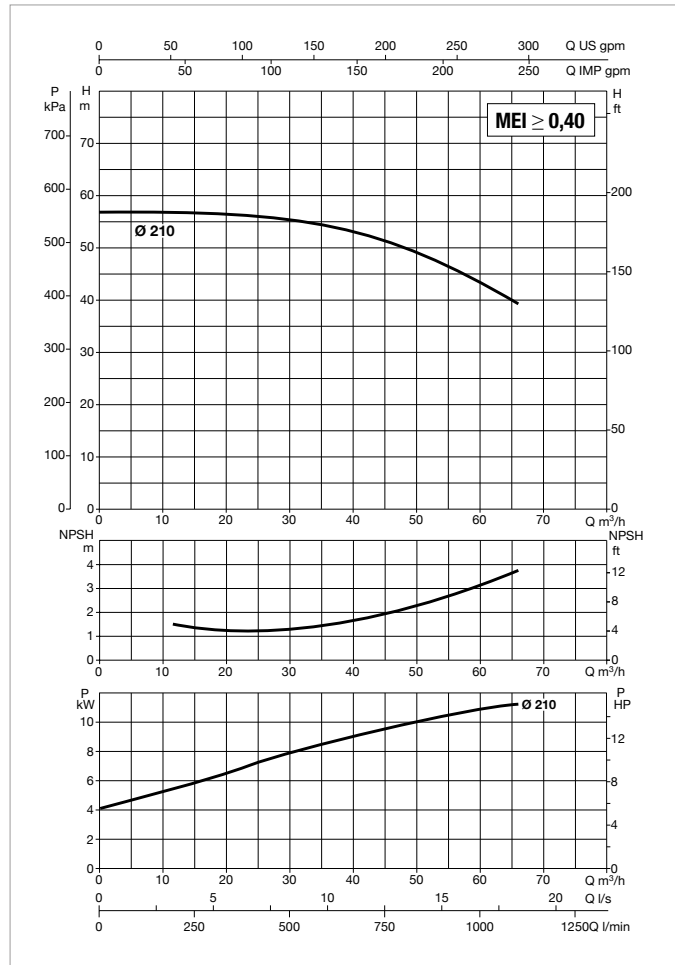
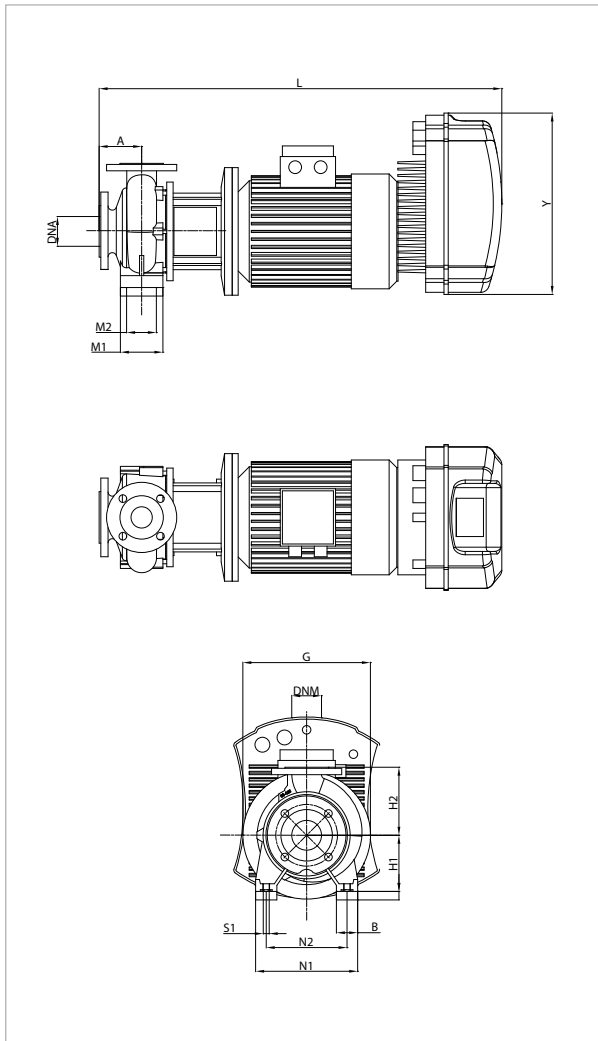

See hydraulic efficiency details on page 241.

The performance curves are based on kinematic viscosity values = 1 mm²/s and density equal to 1000 kg/m³. Curve tolerance according to ISO 9906.

MODEL	MCE MODEL	POWER INPUT 50 Hz	P2 NOMINAL		In A
			kW	HP	
NKP-GE 40-200/210/A/BAQE/11/2 T MCE110/C	MCE110/C	3 x 400 ~V	11,00	15,0	24,9

MODEL	A	B	G	H1	H2	L	M1	M2	N1	N2	S1	X	Y	DNA	DNM	PACKING DIMENSIONS			WEIGHT kg
																L/A	L/B	H	
NKP-GE 40-200/210/A/BAQE/11/2 T MCE110/C	100	67	350	160	180	1053	-	-	314	254	M12	100	426	65	40	1100	550	620	207

NKP-GE 40-200 - STANDARDISED MONOBLOC CENTRIFUGAL ELECTRIC PUMPS WITH INVERTER FOR PRESSURISATION SYSTEMS



Pumped liquid temperature range: from -10 °C to +80 °C (MCE/P) - Maximum ambient temperature: +40 °C

≅ 2900 1/min

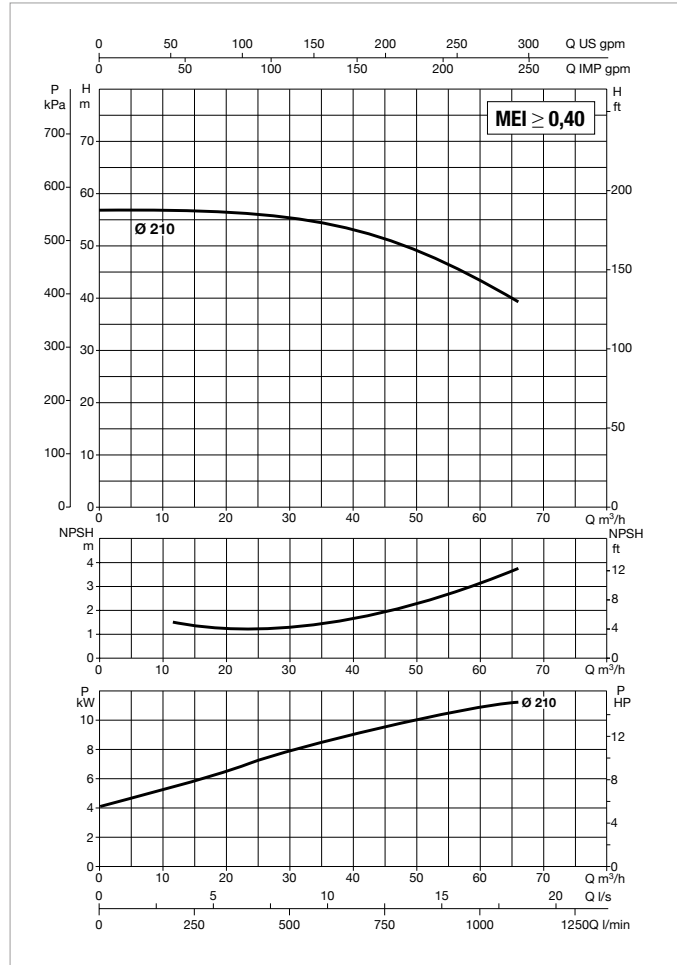
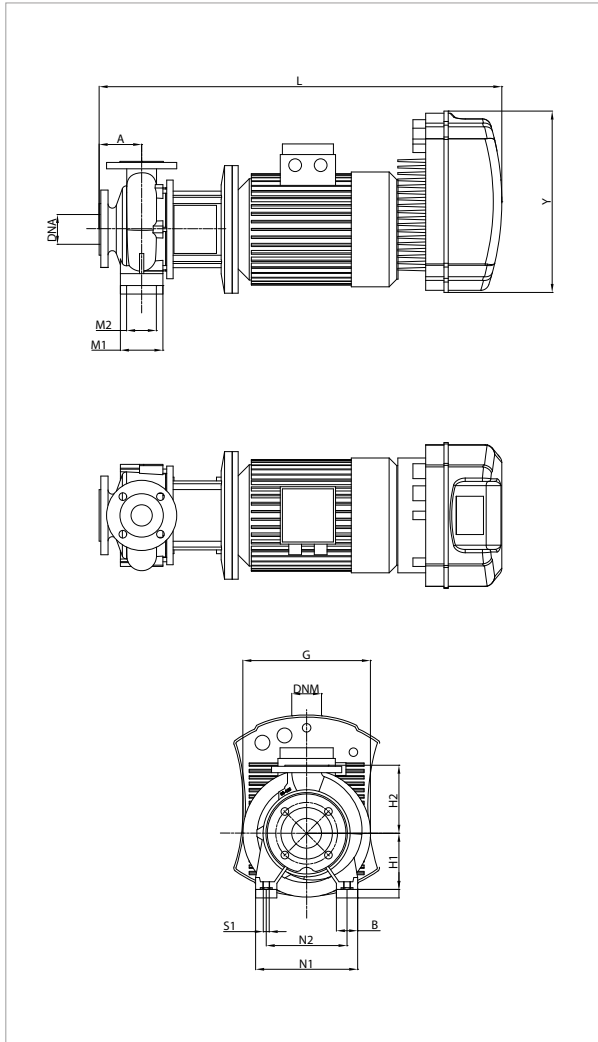

See hydraulic efficiency details on page 241.

The performance curves are based on kinematic viscosity values = 1 mm²/s and density equal to 1000 kg/m³. Curve tolerance according to ISO 9906.

MODEL	MCE MODEL	POWER INPUT 50 Hz	P2 NOMINAL		In A
			kW	HP	
NKP-GE 40-200/210/A/BAQE/11/2 MCE150/P	MCE150/P	3 x 400 ~V	11,0	15,0	24,87

MODEL	A	B	G	H1	H2	L	M1	M2	N1	N2	S1	X	Y	DNA	DNM	PACKING DIMENSIONS			WEIGHT kg
																L/A	L/B	H	
NKP-GE 40-200/210/A/BAQE/11/2 MCE150/P	100	67	350	160	180	1098	-	-	314	254	M12	100	426	65	40	1386	526	676	207

NKP-GE 40-250 - STANDARDISED MONOBLOC CENTRIFUGAL ELECTRIC PUMPS

WITH INVERTER FOR CIRCULATION OR PRESSURISATION SYSTEMS



Pumped liquid temperature range: from -10 °C to +140 °C (MCE/C) - from -10 °C to +80 °C (MCE/P) - Maximum ambient temperature: +40 °C
 ≈ 2900 1/min

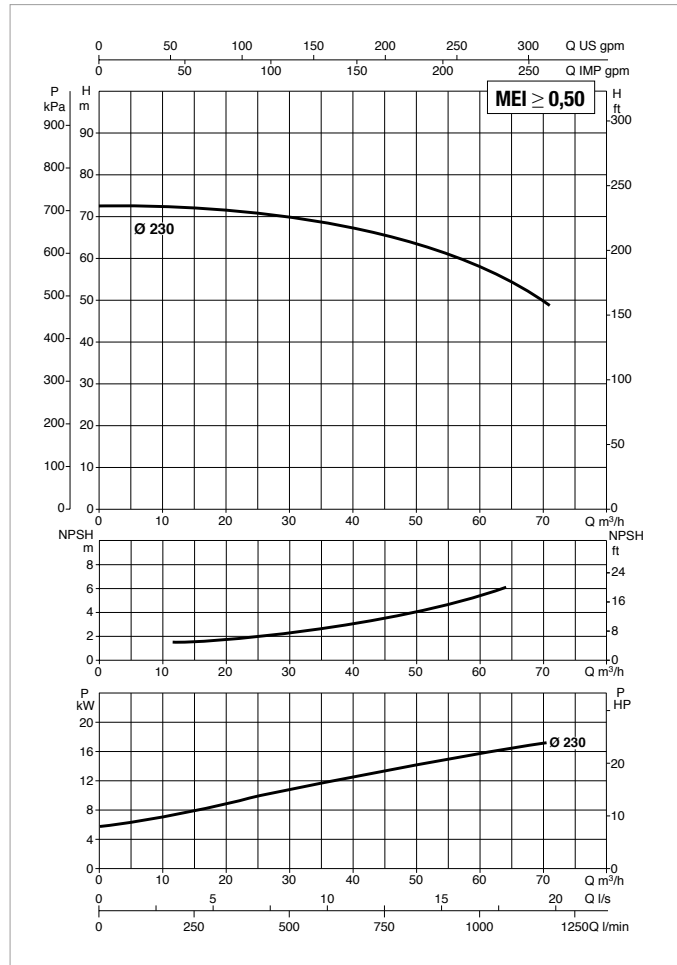
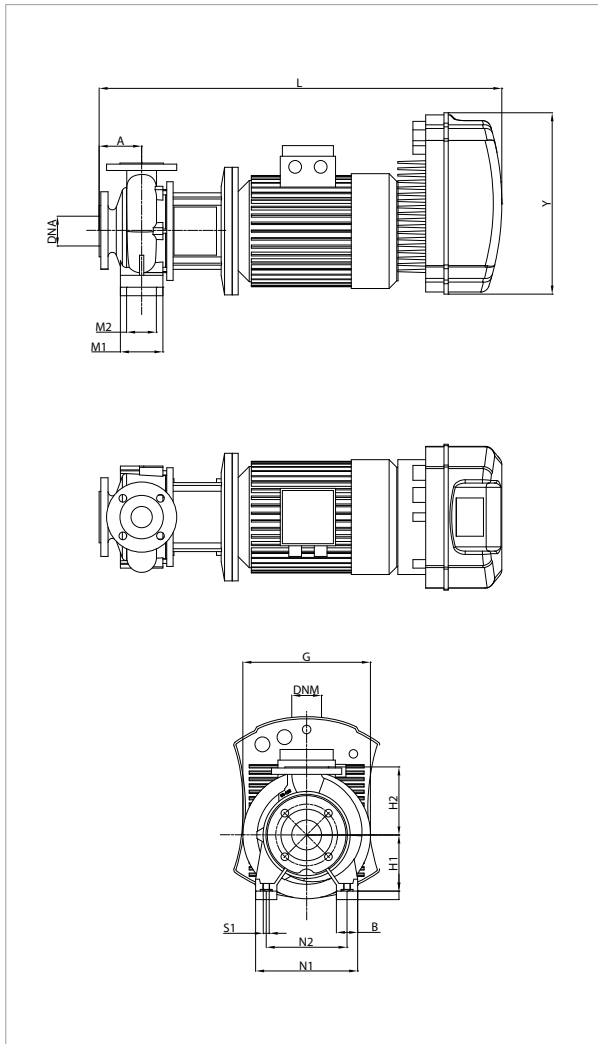

See hydraulic efficiency details on page 241.
 The performance curves are based on kinematic viscosity values = 1 mm²/s and density equal to 1000 kg/m³. Curve tolerance according to ISO 9906.

MODEL	MCE MODEL	POWER INPUT 50 Hz	P2 NOMINAL		In A
			kW	HP	
NKP-GE 40-250/230/A/BAQE/15/2 T MCE150/C-P	MCE150/C - MCE150/P	3 x 400 ~V	15,00	20,0	34,5

MODEL	A	B	G	H1	H2	L	M1	M2	N1	N2	S1	X	Y	DNA	DNM	PACKING DIMENSIONS			WEIGHT kg
																L/A	L/B	H	
NKP-GE 40-250/230/A/BAQE/15/2 T MCE150/C-P	100	67	350	160	225	1053	-	-	314	254	M12	100	426	65	40	1100	550	620	220

NKP-GE 50-125 - STANDARDISED MONOBLOC CENTRIFUGAL ELECTRIC PUMPS WITH INVERTER FOR CIRCULATION SYSTEMS



Pumped liquid temperature range: from -10 °C to +140 °C (MCE/C) - Maximum ambient temperature: +40 °C

≈ 2900 1/min

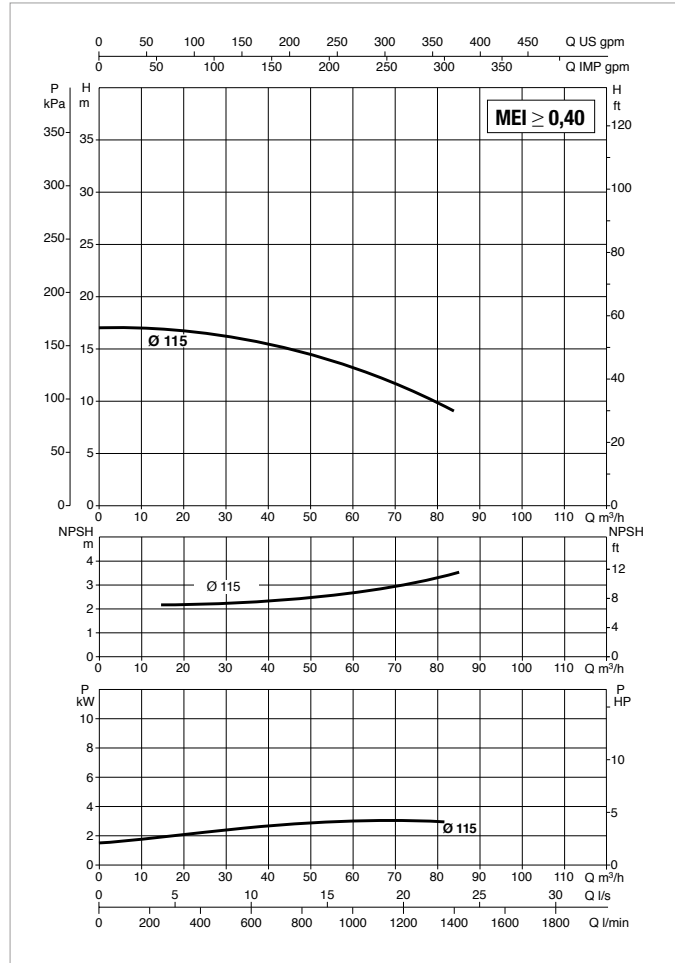
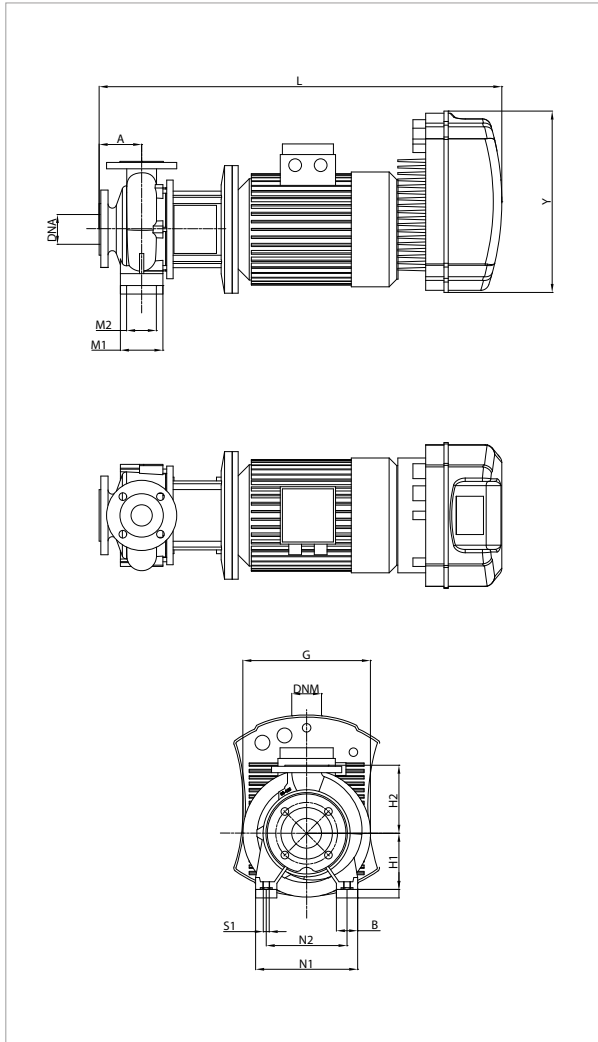

See hydraulic efficiency details on page 241.

The performance curves are based on kinematic viscosity values = 1 mm²/s and density equal to 1000 kg/m³. Curve tolerance according to ISO 9906.

MODEL	MCE MODEL	POWER INPUT 50 Hz	P2 NOMINAL		In A
			kW	HP	
NKP-GE 50-125/115/A/BAQE/3/2 T MCE30/C	MCE30/C	3 x 400 ~V	3,00	4,0	7,2

MODEL	A	B	G	H1	H2	L	M1	M2	N1	N2	S1	X	Y	DNA	DNM	PACKING DIMENSIONS			WEIGHT kg
																L/A	L/B	H	
NKP-GE 50-125/115/A/BAQE/3/2 T MCE30/C	100	50	251	132	160	775	100	70	240	190	M10	100	353	65	50	1100	550	620	87

NKP-GE 50-125 - STANDARDISED MONOBLOC CENTRIFUGAL ELECTRIC PUMPS WITH INVERTER FOR PRESSURISATION SYSTEMS



Pumped liquid temperature range: from -10 °C to +80 °C (MCE/P) - Maximum ambient temperature: +40 °C

≈ 2900 1/min

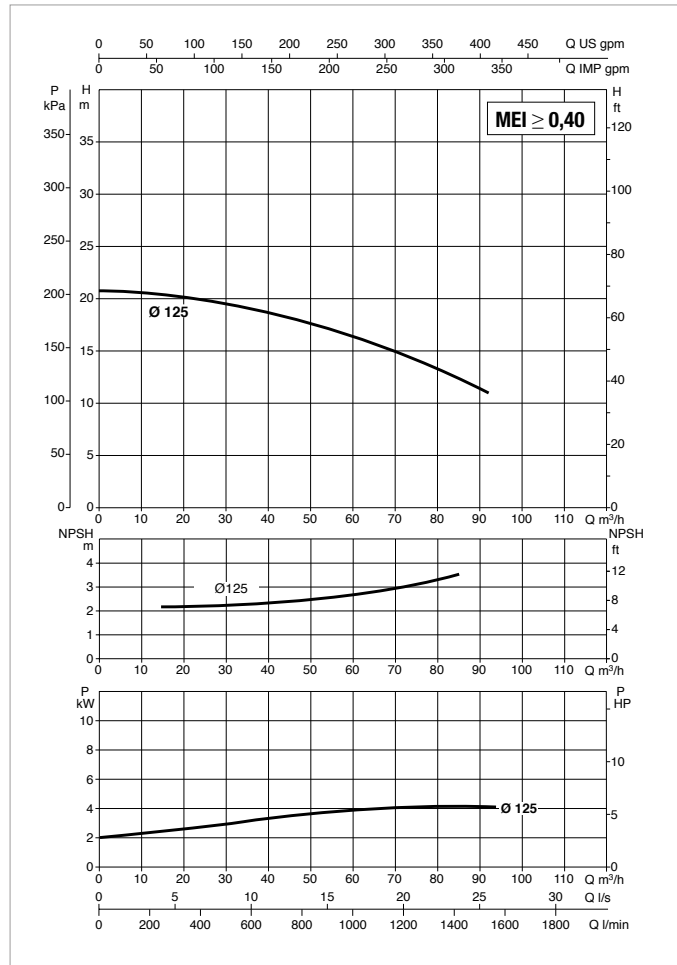
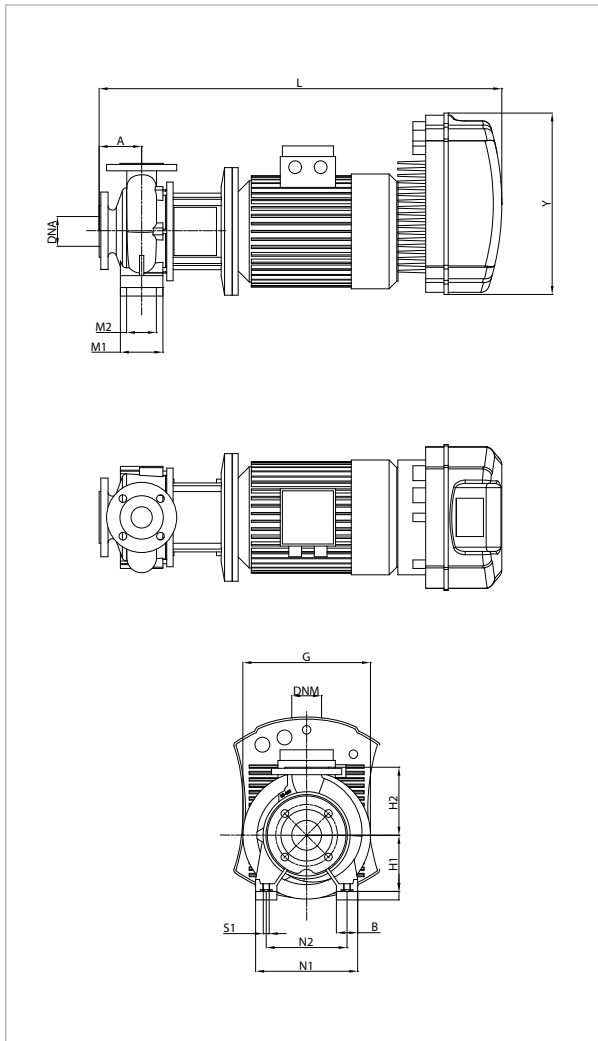

See hydraulic efficiency details on page 241.

The performance curves are based on kinematic viscosity values = 1 mm²/s and density equal to 1000 kg/m³. Curve tolerance according to ISO 9906.

MODEL	MCE MODEL	POWER INPUT 50 Hz	P2 NOMINAL		In A
			kW	HP	
NKP-GE 50-125/125/A/BAQE/4/2 MCE55/P	MCE55/P	3 x 400 ~V	4,0	5,5	9,78

MODEL	A	B	G	H1	H2	L	M1	M2	N1	N2	S1	X	Y	DNA	DNM	PACKING DIMENSIONS			WEIGHT kg
																L/A	L/B	H	
NKP-GE 50-125/125/A/BAQE/4/2 MCE55/P	100	50	267	132	160	814	100	70	240	190	M10	100	353	65	50	1026	530	546	122

NKP-GE 50-125 - STANDARDISED MONOBLOC CENTRIFUGAL ELECTRIC PUMPS

WITH INVERTER FOR CIRCULATION OR PRESSURISATION SYSTEMS



Pumped liquid temperature range: from -10 °C to +140 °C (MCE/C) - from -10 °C to +80 °C (MCE/P) - Maximum ambient temperature: +40 °C
 ≈ 2900 1/min

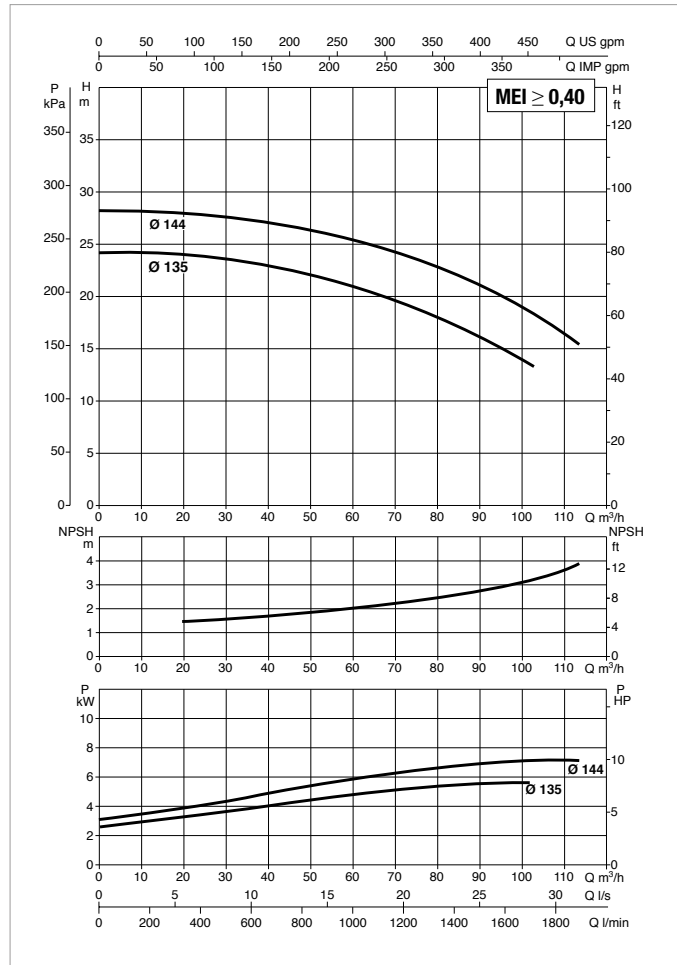
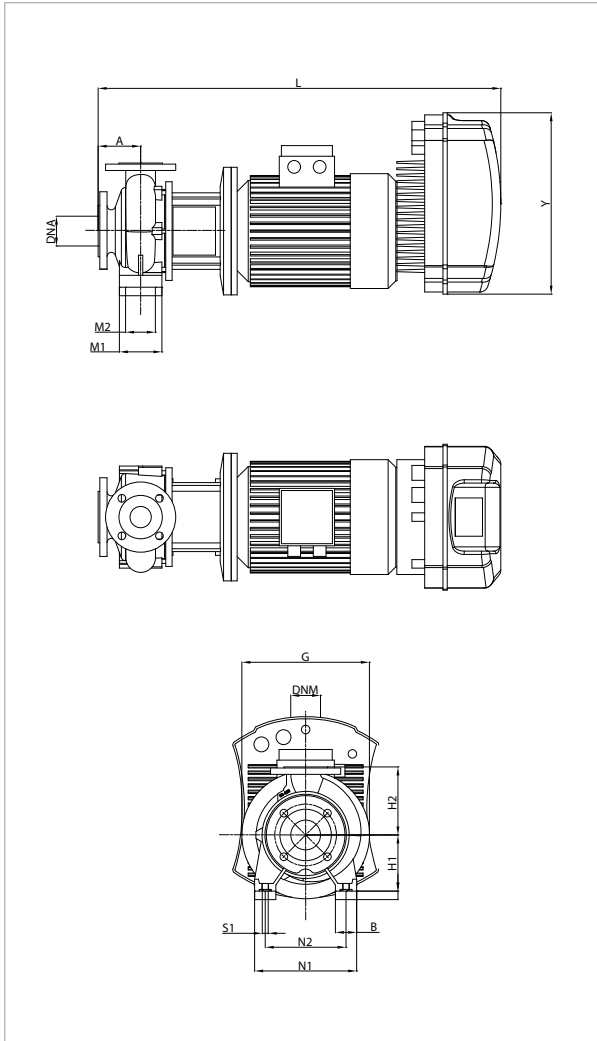

See hydraulic efficiency details on page 241.
 The performance curves are based on kinematic viscosity values = 1 mm²/s and density equal to 1000 kg/m³. Curve tolerance according to ISO 9906.

MODEL	MCE MODEL	POWER INPUT 50 Hz	P2 NOMINAL		In A
			kW	HP	
NKP-GE 50-125/135/A/BAQE/5,5/2 T MCE55/C-P	MCE55/C - MCE55/P	3 x 400 ~V	5,50	7,5	12,6
NKP-GE 50-125/144/A/BAQE/7,5/2 T MCE110/C-P	MCE110/C - MCE110/P	3 x 400 ~V	7,50	10,0	17,1

MODEL	A	B	G	H1	H2	L	M1	M2	N1	N2	S1	X	Y	DNA	DNM	PACKING DIMENSIONS			WEIGHT kg
																L/A	L/B	H	
NKP-GE 50-125/135/A/BAQE/5,5/2 T MCE55/C-P	100	50	300	132	160	903	100	70	240	190	M10	100	353	65	50	1100	550	620	124
NKP-GE 50-125/144/A/BAQE/7,5/2 T MCE110/C-P	100	50	300	132	160	953	100	70	240	190	M10	100	426	65	50	1100	550	620	133

NKP-GE 50-160 - STANDARDISED MONOBLOC CENTRIFUGAL ELECTRIC PUMPS WITH INVERTER FOR PRESSURISATION SYSTEMS



Pumped liquid temperature range: from -10 °C to +80 °C (MCE/P) - Maximum ambient temperature: +40 °C

≈ 2900 1/min

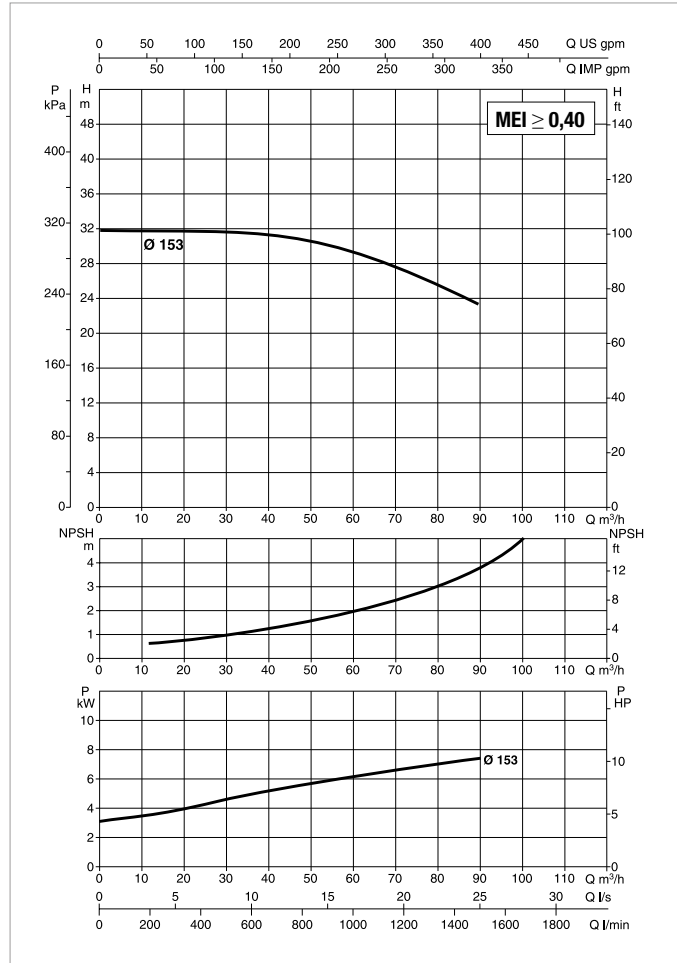
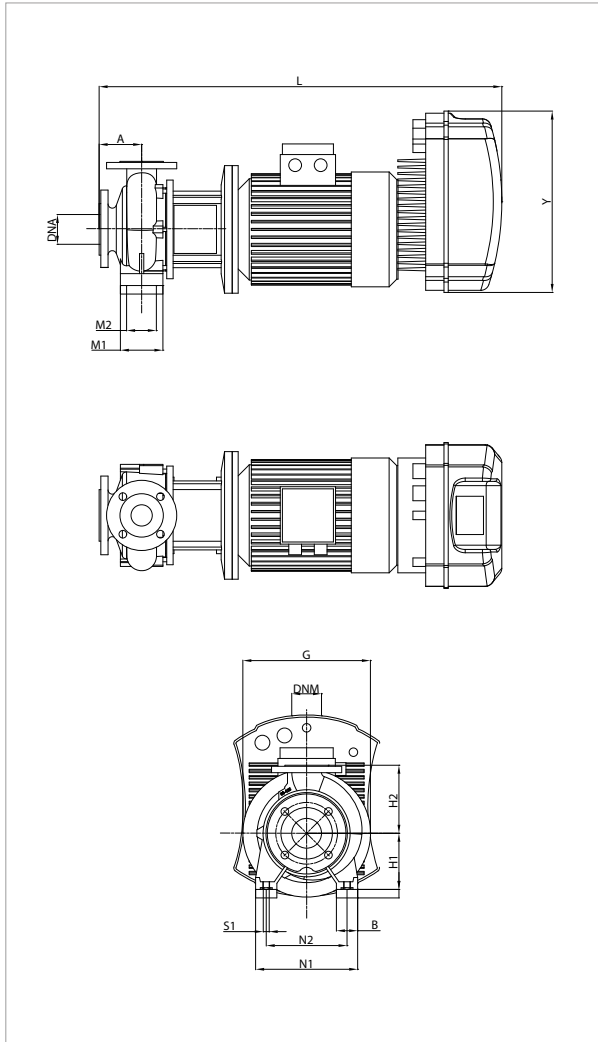

See hydraulic efficiency details on page 241.

The performance curves are based on kinematic viscosity values = 1 mm²/s and density equal to 1000 kg/m³. Curve tolerance according to ISO 9906.

MODEL	MCE MODEL	POWER INPUT 50 Hz	P2 NOMINAL		In A
			kW	HP	
NKP-GE50-160/153/A/BAQE/7.5/2MCE110/P	MCE110/P	3 x 400 -V	7,5	10,0	17,38

MODEL	A	B	G	H1	H2	L	M1	M2	N1	N2	S1	X	Y	DNA	DNM	PACKING DIMENSIONS			WEIGHT kg
																L/A	L/B	H	
NKP-GE50-160/153/A/BAQE/7.5/2MCE110/P	100	50	341	160	180	953	100	70	265	212	M10	100	426	65	50	1026	530	546	101

NKP-GE 50-160 - STANDARDISED MONOBLOC CENTRIFUGAL ELECTRIC PUMPS WITH INVERTER FOR CIRCULATION SYSTEMS



Pumped liquid temperature range: from -10 °C to +140 °C (MCE/C) - Maximum ambient temperature: +40 °C

≈ 2900 1/min

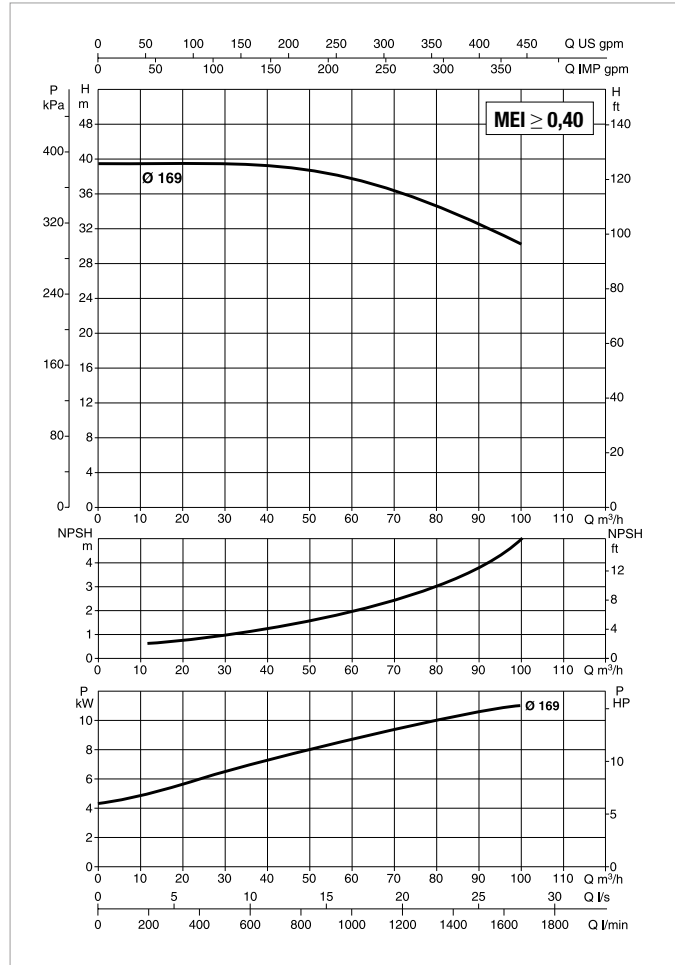
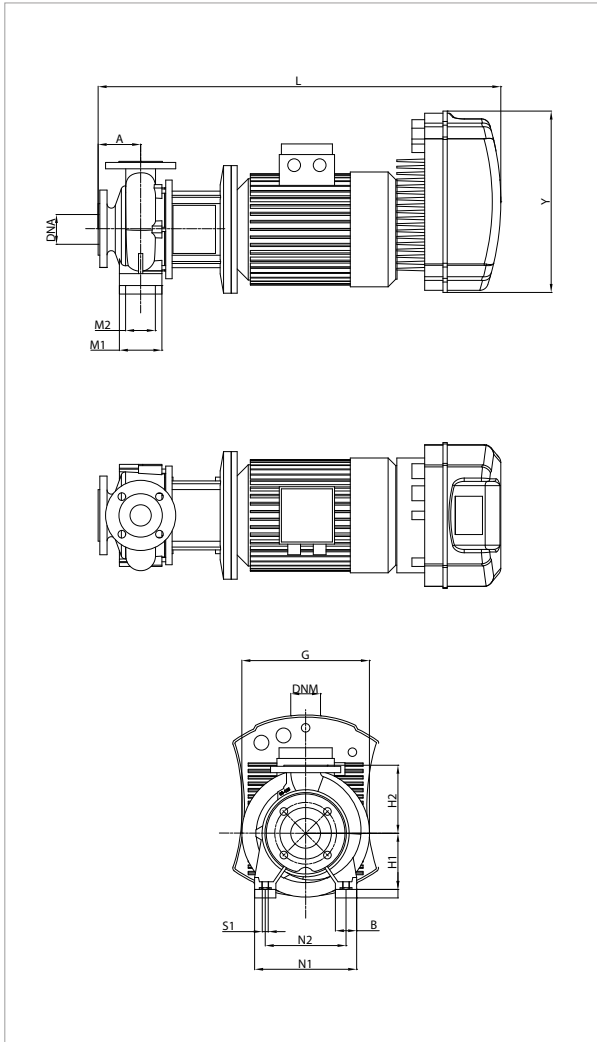

See hydraulic efficiency details on page 241.

The performance curves are based on kinematic viscosity values = 1 mm²/s and density equal to 1000 kg/m³. Curve tolerance according to ISO 9906.

MODEL	MCE MODEL	POWER INPUT 50 Hz	P2 NOMINAL		In A
			kW	HP	
NKP-GE 50-160/169/A/BAQE/11/2 T MCE110/C	MCE110/C	3 x 400 -V	11,00	15,0	24,0

MODEL	A	B	G	H1	H2	L	M1	M2	N1	N2	S1	X	Y	DNA	DNM	PACKING DIMENSIONS			WEIGHT kg
																L/A	L/B	H	
NKP-GE 50-160/169/A/BAQE/11/2 T MCE110/C	100	67	350	160	180	1053	-	-	314	254	M12	100	426	65	50	1100	550	620	132

NKP-GE 50-160 - STANDARDISED MONOBLOC CENTRIFUGAL ELECTRIC PUMPS WITH INVERTER FOR PRESSURISATION SYSTEMS



Pumped liquid temperature range: from -10 °C to +80 °C (MCE/P) - Maximum ambient temperature: +40 °C

≈ 2900 1/min

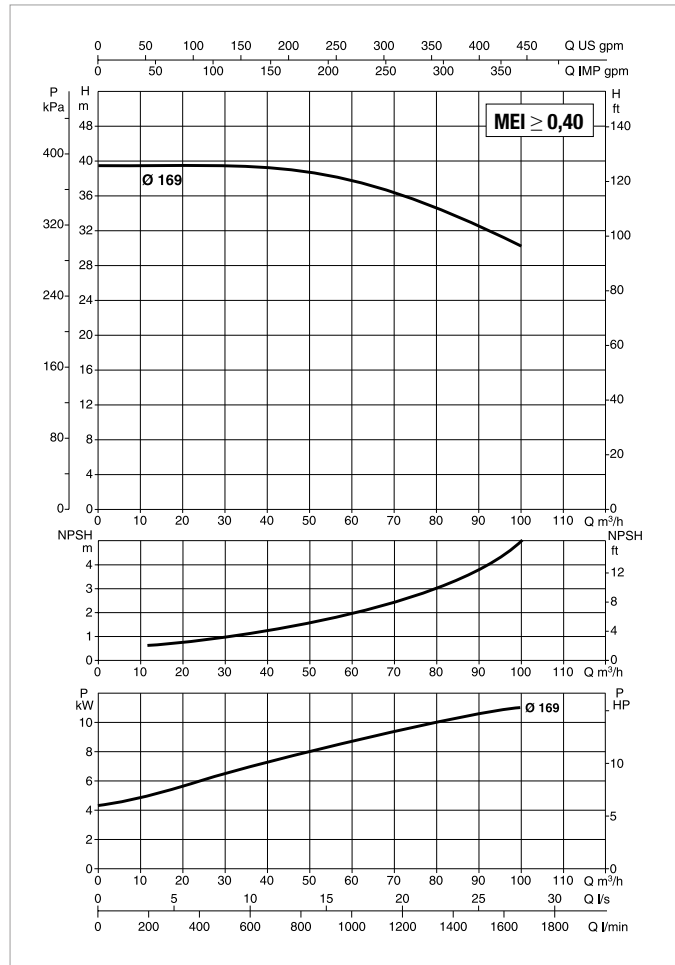
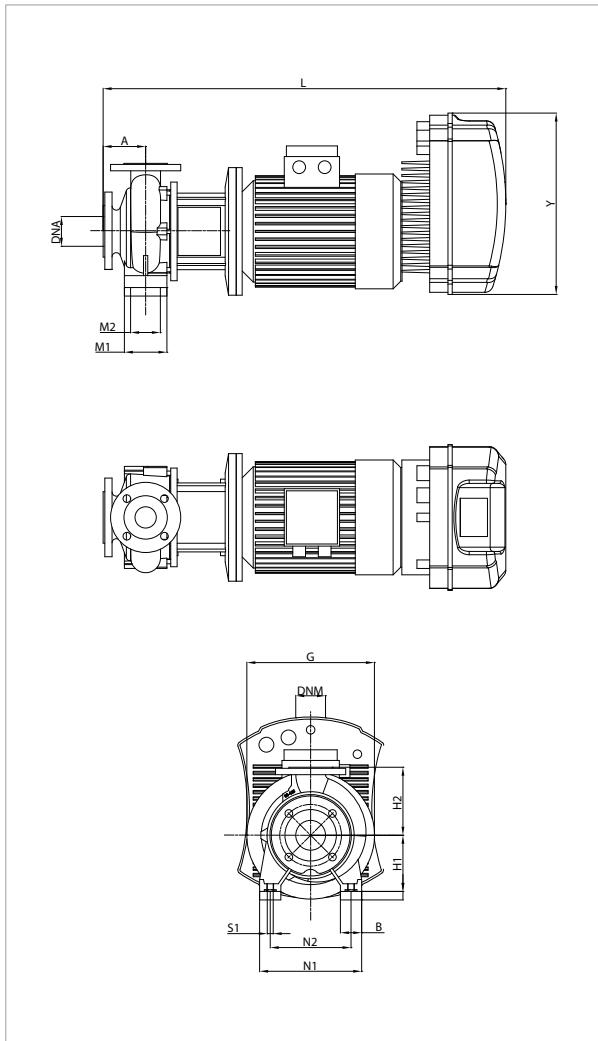

See hydraulic efficiency details on page 241.

The performance curves are based on kinematic viscosity values = 1 mm²/s and density equal to 1000 kg/m³. Curve tolerance according to ISO 9906.

MODEL	MCE MODEL	POWER INPUT 50 Hz	P2 NOMINAL		In A
			kW	HP	
NKP-GE50-160/169/A/BAQE/11/2 MCE150/P	MCE150/P	3 x 400 -V	11,0	15,0	24,03

MODEL	A	B	G	H1	H2	L	M1	M2	N1	N2	S1	X	Y	DNA	DNM	PACKING DIMENSIONS			WEIGHT kg
																L/A	L/B	H	
NKP-GE50-160/169/A/BAQE/11/2 MCE150/P	100	67	350	160	180	1098	-	-	314	254	M12	100	426	65	50	1386	526	676	132

NKP-GE 50-200 - STANDARDISED MONOBLOC CENTRIFUGAL ELECTRIC PUMPS WITH INVERTER FOR CIRCULATION OR PRESSURIZATION SYSTEMS

MCE-C

MCE-P

Pumped liquid temperature range: from -10 °C to +140 °C (MCE/C) - from -10 °C to +80 °C (MCE/P) - Maximum ambient temperature: +40 °C

≈ 2900 1/min

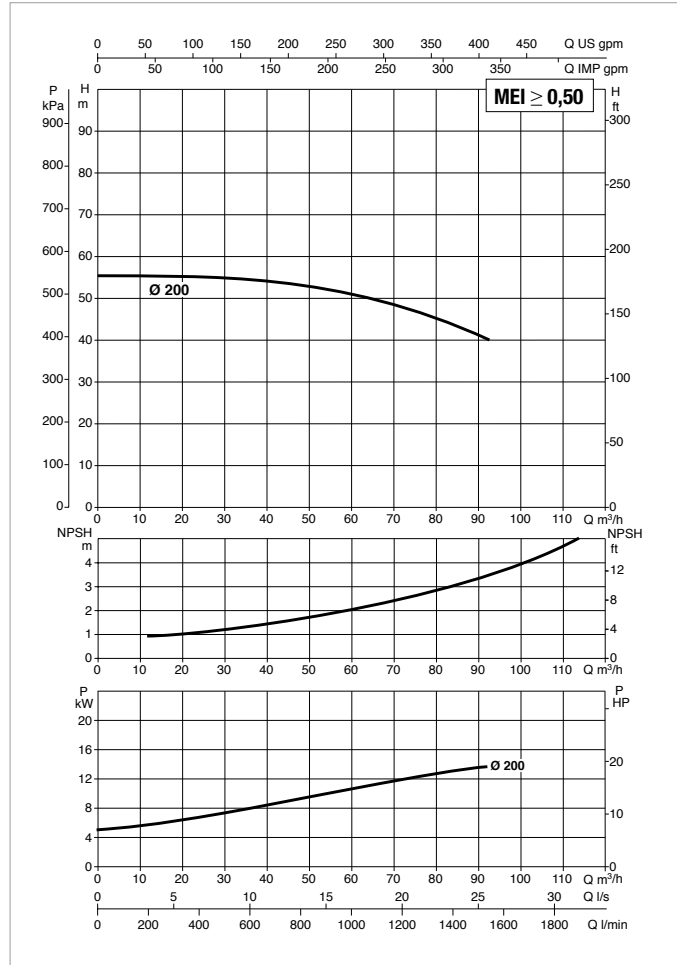
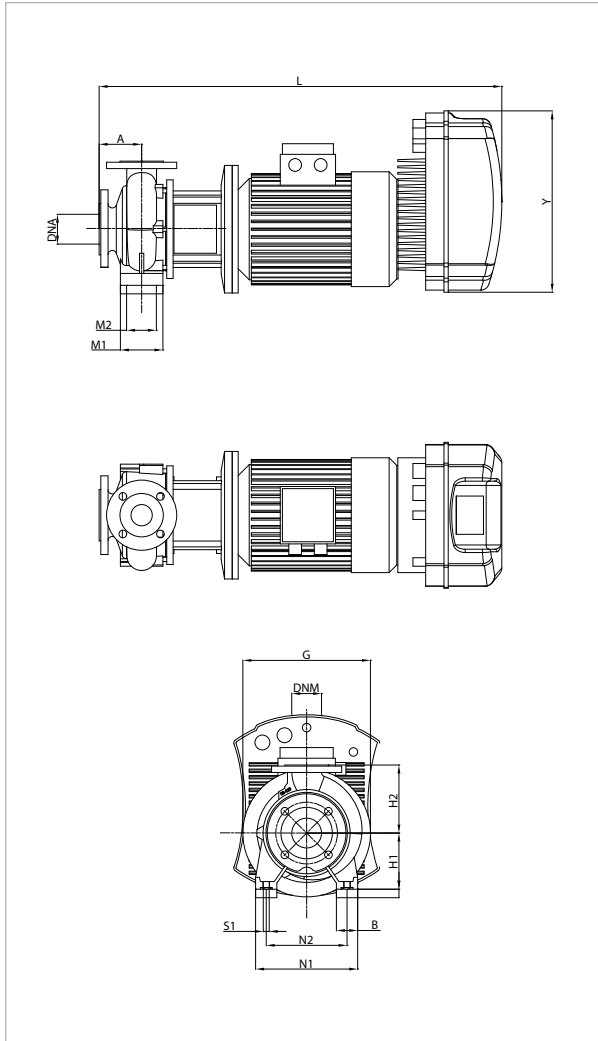

See hydraulic efficiency details on page 241.

The performance curves are based on kinematic viscosity values = 1 mm²/s and density equal to 1000 kg/m³. Curve tolerance according to ISO 9906.

MODEL	MCE MODEL	POWER INPUT 50 Hz	P2 NOMINAL		In A
			kW	HP	
NKP-GE 50-200/200/A/BAQE/15/2 T MCE150/C-P	MCE150/C - MCE150/P	3 x 400 ~V	15,00	20,0	32,5

MODEL	A	B	G	H1	H2	L	M1	M2	N1	N2	S1	X	Y	DNA	DNM	PACKING DIMENSIONS			WEIGHT kg
																L/A	L/B	H	
NKP-GE 50-200/200/A/BAQE/15/2 T MCE150/C-P	100	67	350	160	200	1053	-	-	314	254	M12	100	426	65	50	1100	550	620	216

NKP-GE 65-125 - STANDARDISED MONOBLOC CENTRIFUGAL ELECTRIC PUMPS

WITH INVERTER FOR CIRCULATION OR PRESSURISATION SYSTEMS



Pumped liquid temperature range: from -10 °C to +140 °C (MCE/C) - from -10 °C to +80 °C (MCE/P) - Maximum ambient temperature: +40 °C
 ≈ 2900 1/min

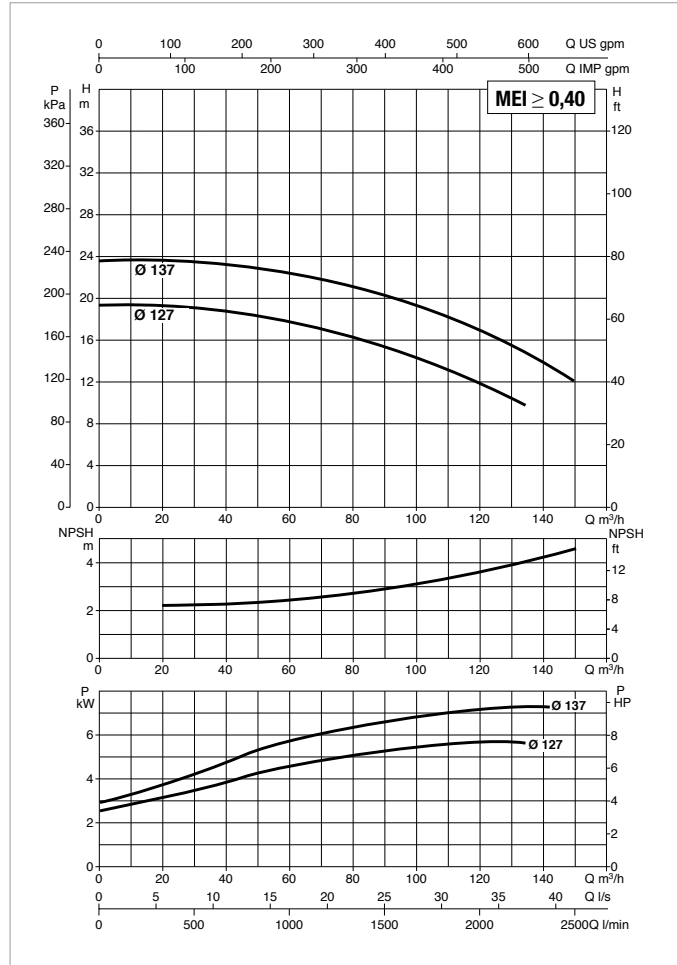
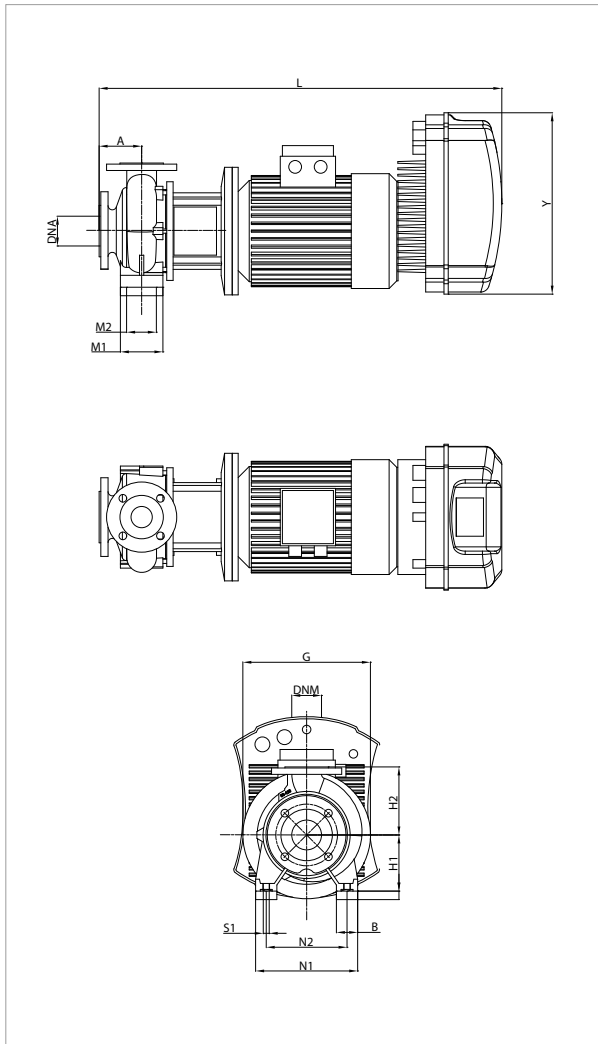

See hydraulic efficiency details on page 241.

The performance curves are based on kinematic viscosity values = 1 mm²/s and density equal to 1000 kg/m³. Curve tolerance according to ISO 9906.

MODEL	MCE MODEL	POWER INPUT 50 Hz	P2 NOMINAL		In A
			kW	HP	
NKP-GE 65-125/127/A/BAQE/5.5/2 T MCE55/C-P	MCE55/C - MCE55/P	3 x 400 ~V	5,50	7,5	12,8
NKP-GE 65-125/137/A/BAQE/7.5/2 T MCE110/C-P	MCE110/C - MCE110/P	3 x 400 ~V	7,50	10,0	17,4

MODEL	A	B	G	H1	H2	L	M1	M2	N1	N2	S1	X	Y	DNA	DNM	PACKING DIMENSIONS			WEIGHT kg
																L/A	L/B	H	
NKP-GE 65-125/127/A/BAQE/5.5/2 T MCE55/C-P	100	65	300	160	180	903	125	95	280	212	M10	100	353	80	65	1100	550	620	122
NKP-GE 65-125/137/A/BAQE/7.5/2 T MCE110/C-P	100	65	300	160	180	953	125	95	280	212	M10	100	426	80	65	1100	550	620	131

NKP-GE 65-160 - STANDARDISED MONOBLOC CENTRIFUGAL ELECTRIC PUMPS WITH INVERTER FOR CIRCULATION SYSTEMS



Pumped liquid temperature range: from -10 °C to +140 °C (MCE/C) - Maximum ambient temperature: +40 °C

≅ 2900 1/min

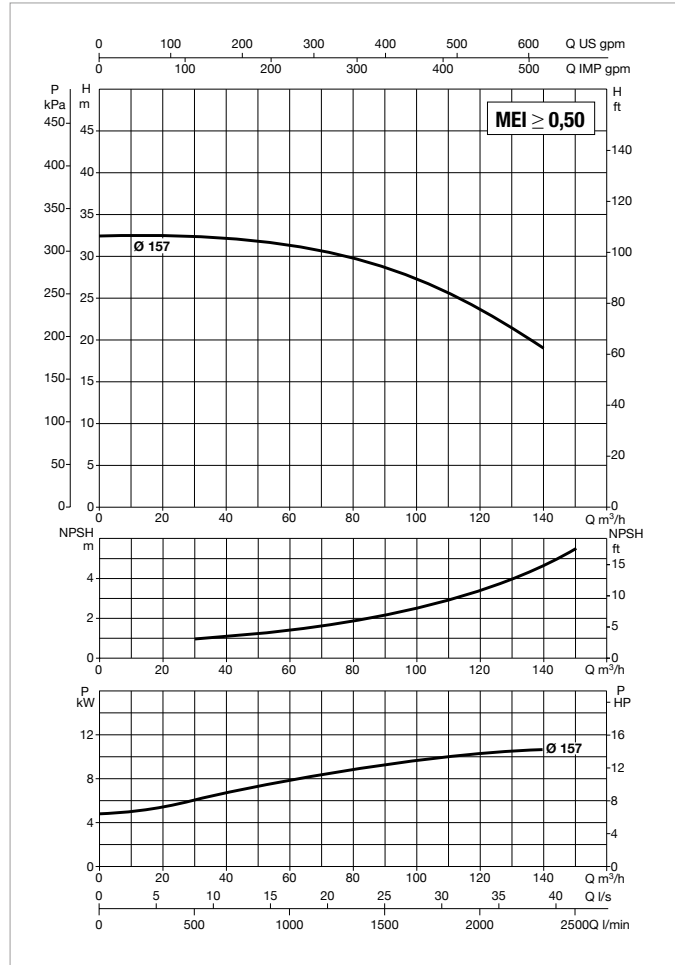
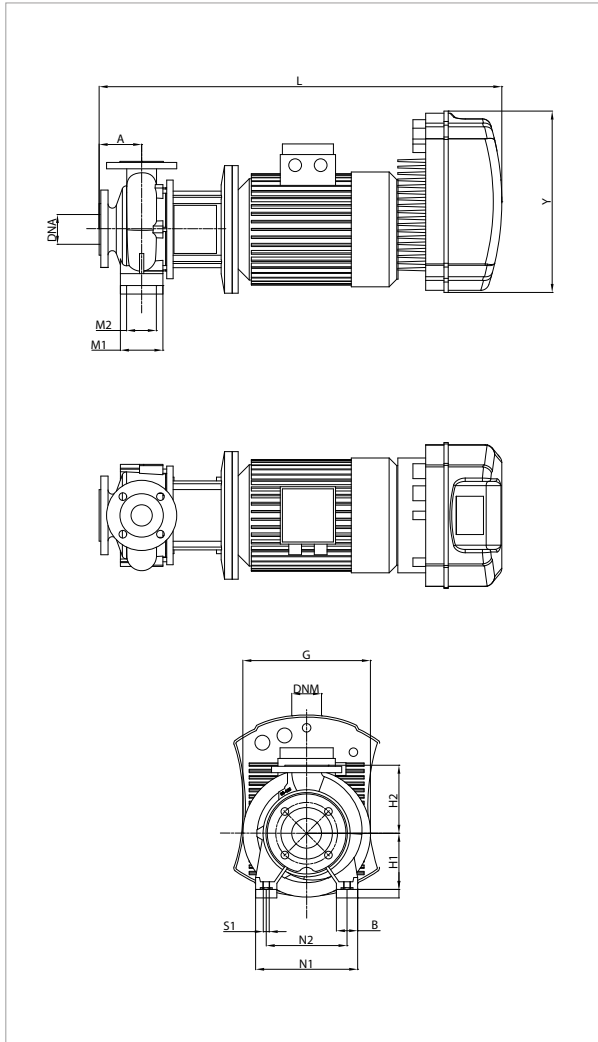

See hydraulic efficiency details on page 241.

The performance curves are based on kinematic viscosity values = 1 mm²/s and density equal to 1000 kg/m³. Curve tolerance according to ISO 9906.

MODEL	MCE MODEL	POWER INPUT 50 Hz	P2 NOMINAL		In A
			kW	HP	
NKP-GE 65-160/157/A/BAQE/11/2 T MCE110/C	MCE110/C	3 x 400 ~V	11,00	15,0	23,4

MODEL	A	B	G	H1	H2	L	M1	M2	N1	N2	S1	X	Y	DNA	DNM	PACKING DIMENSIONS			WEIGHT kg
																L/A	L/B	H	
NKP-GE 65-160/157/A/BAQE/11/2 T MCE110/C	100	67	350	160	200	1053	-	-	314	254	M12	100	426	80	65	1100	550	620	202

NKP-GE 65-160 - STANDARDISED MONOBLOC CENTRIFUGAL ELECTRIC PUMPS WITH INVERTER FOR PRESSURISATION SYSTEMS



Pumped liquid temperature range: from -10 °C to +80 °C (MCE/P) - Maximum ambient temperature: +40 °C

≈ 2900 1/min

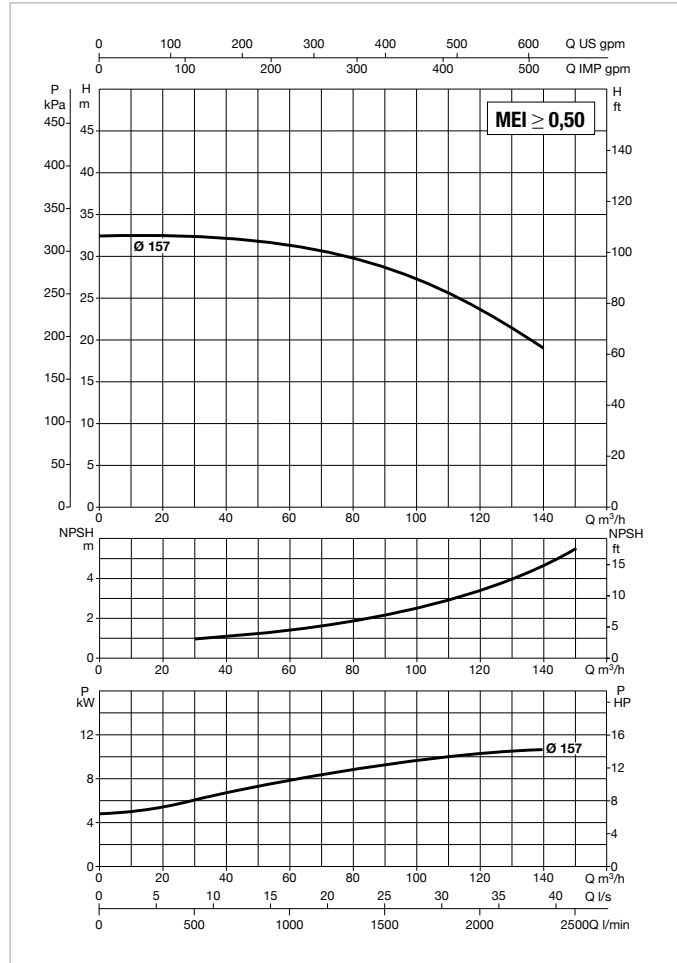
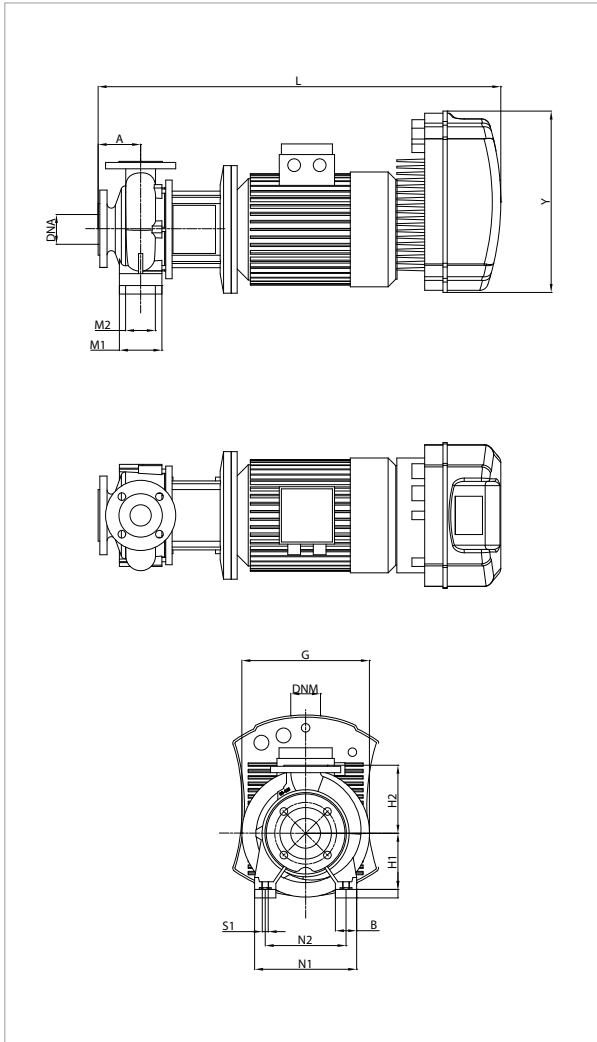

See hydraulic efficiency details on page 241.

The performance curves are based on kinematic viscosity values = 1 mm²/s and density equal to 1000 kg/m³. Curve tolerance according to ISO 9906.

MODEL	MCE MODEL	POWER INPUT 50 Hz	P2 NOMINAL		In A
			kW	HP	
NKP-GE65-160/157/A/BAQE/11/2MCE150/P	MCE150/P	3 x 400 -V	11,00	15,0	23,44

MODEL	A	B	G	H1	H2	L	M1	M2	N1	N2	S1	X	Y	DNA	DNM	PACKING DIMENSIONS			WEIGHT kg
																L/A	L/B	H	
NKP-GE65-160/157/A/BAQE/11/2MCE150/P	100	67	350	160	200	1098	-	-	314	254	M12	100	426	80	65	1386	526	676	202

NKP-GE 65-160 - STANDARDISED MONOBLOC CENTRIFUGAL ELECTRIC PUMPS WITH INVERTER FOR CIRCULATION OR PRESSURIZATION SYSTEMS

MCE-C

MCE-P

Pumped liquid temperature range: from -10 °C to +140 °C (MCE/C) - from -10 °C to +80 °C (MCE/P) - Maximum ambient temperature: +40 °C

≈ 2900 1/min

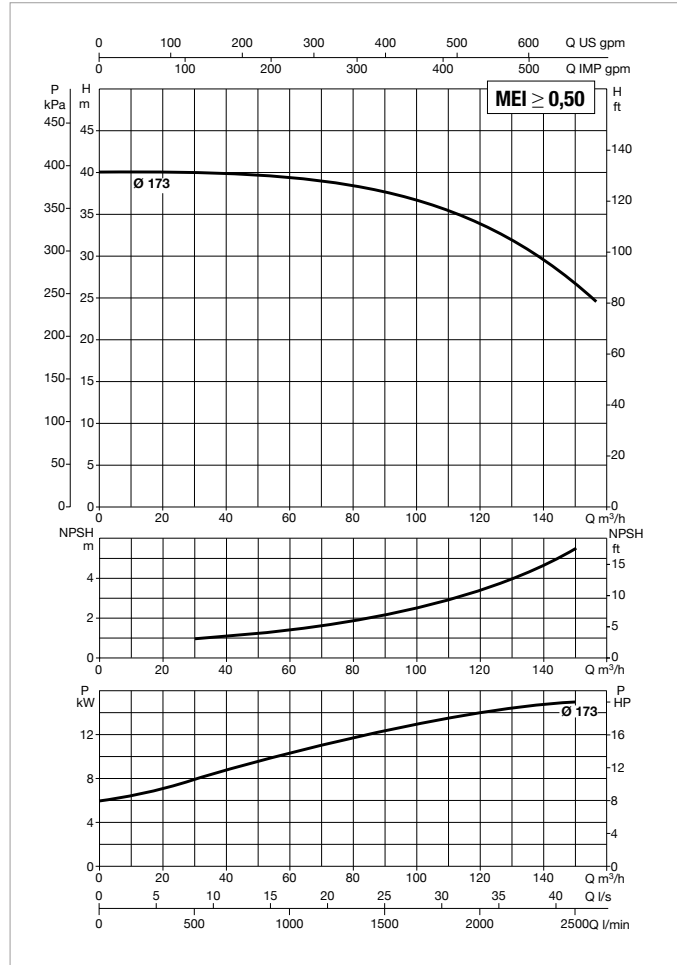
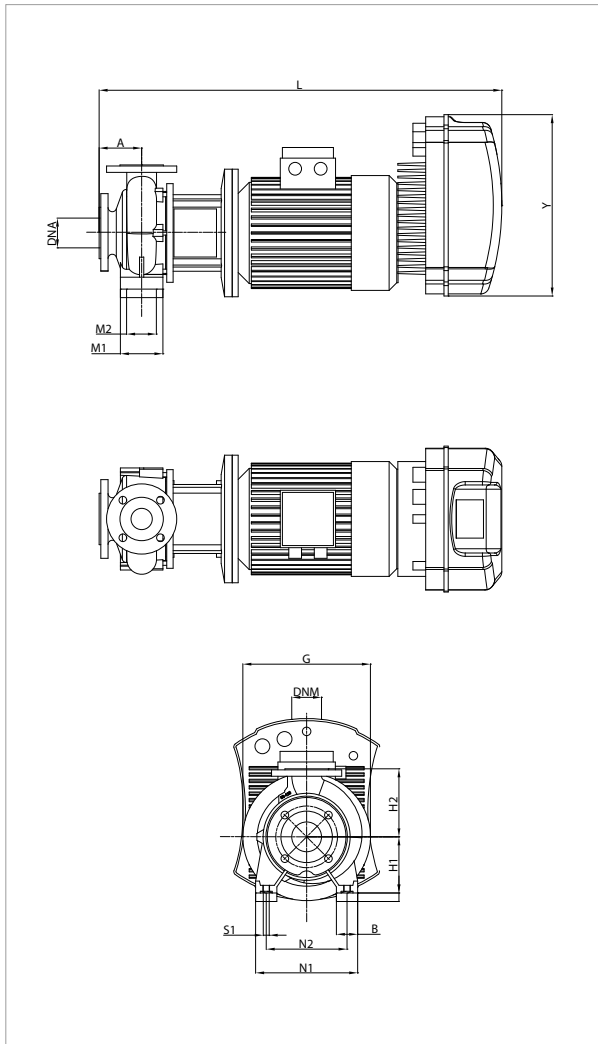

See hydraulic efficiency details on page 241.

The performance curves are based on kinematic viscosity values = 1 mm²/s and density equal to 1000 kg/m³. Curve tolerance according to ISO 9906.

MODEL	MCE MODEL	POWER INPUT 50 Hz	P2 NOMINAL		In A
			kW	HP	
NKP-GE 65-160/173/A/BAQE/15/2 T MCE150/C-P	MCE150/C - MCE150/P	3 x 400 ~V	15,00	20,0	33,5

MODEL	A	B	G	H1	H2	L	M1	M2	N1	N2	S1	X	Y	DNA	DNM	PACKING DIMENSIONS			WEIGHT kg
																L/A	L/B	H	
NKP-GE 65-160/173/A/BAQE/15/2 T MCE150/C-P	100	67	350	160	200	1053	-	-	314	254	M12	100	426	80	65	1100	550	620	212

NKP-GE 80-160 - STANDARDISED MONOBLOC CENTRIFUGAL ELECTRIC PUMPS WITH INVERTER FOR CIRCULATION SYSTEMS



Pumped liquid temperature range: from -10 °C to +140 °C (MCE/C) - Maximum ambient temperature: +40 °C

≈ 2900 1/min

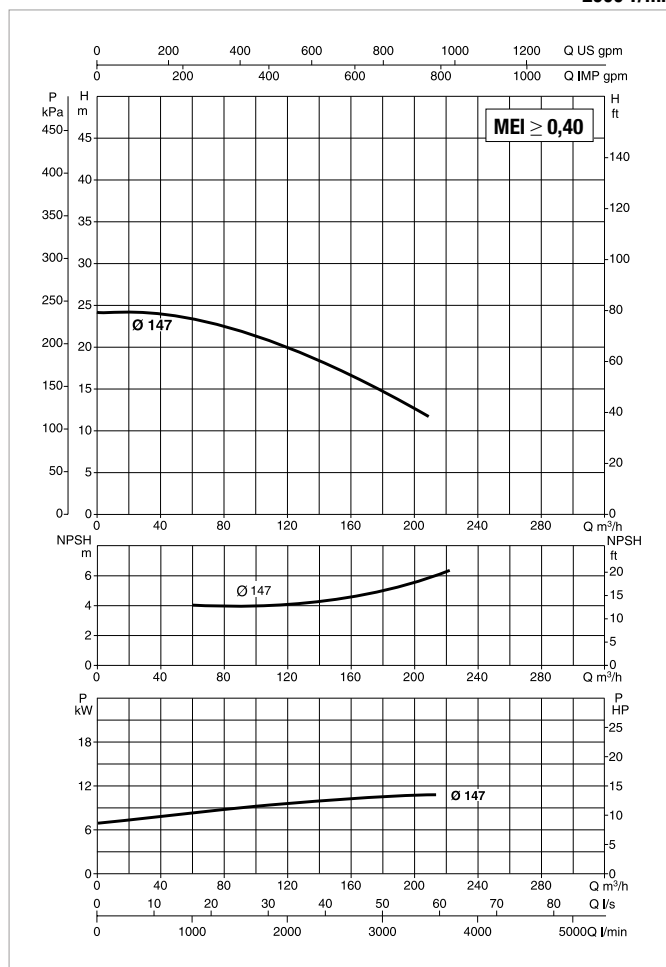
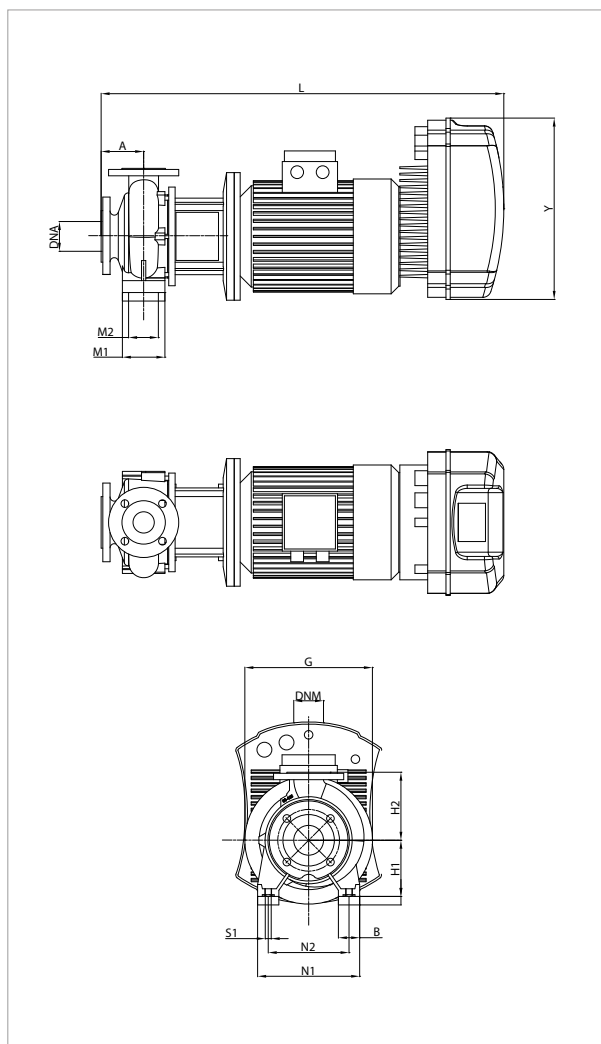

See hydraulic efficiency details on page 241.

The performance curves are based on kinematic viscosity values = 1 mm²/s and density equal to 1000 kg/m³. Curve tolerance according to ISO 9906.

MODEL	MCE MODEL	POWER INPUT 50 Hz	P2 NOMINAL		In A
			kW	HP	
NKP-GE 80-160/147-127/A/BAQE/11/2 T MCE110/C	MCE110/C	3 x 400 ~V	11,00	15,0	24,1

MODEL	A	B	G	H1	H2	L	M1	M2	N1	N2	S1	X	Y	DNA	DNM	PACKING DIMENSIONS			WEIGHT kg
																L/A	L/B	H	
NKP-GE 80-160/147-127/A/BAQE/11/2 T MCE110/C	125	67	350	160	225	1078	-	-	314	254	M12	140	426	100	80	1360	500	530	215

NKP-GE 80-160 - STANDARDISED MONOBLOC CENTRIFUGAL ELECTRIC PUMPS WITH INVERTER FOR PRESSURISATION SYSTEMS



Pumped liquid temperature range: from -10 °C to +80 °C (MCE/P) - Maximum ambient temperature: +40 °C

≅ 2900 1/min

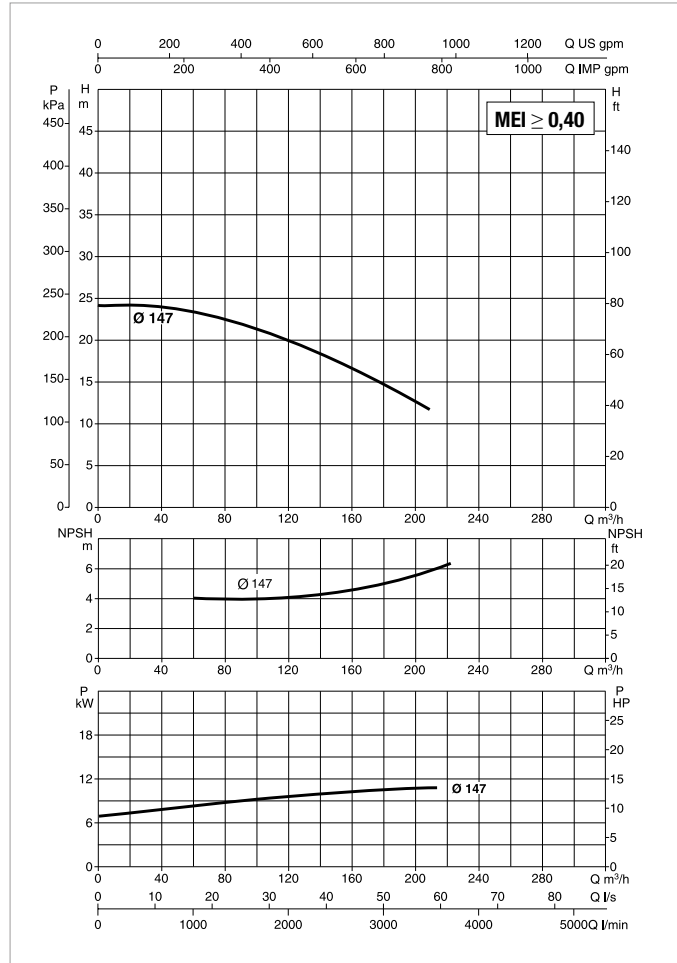
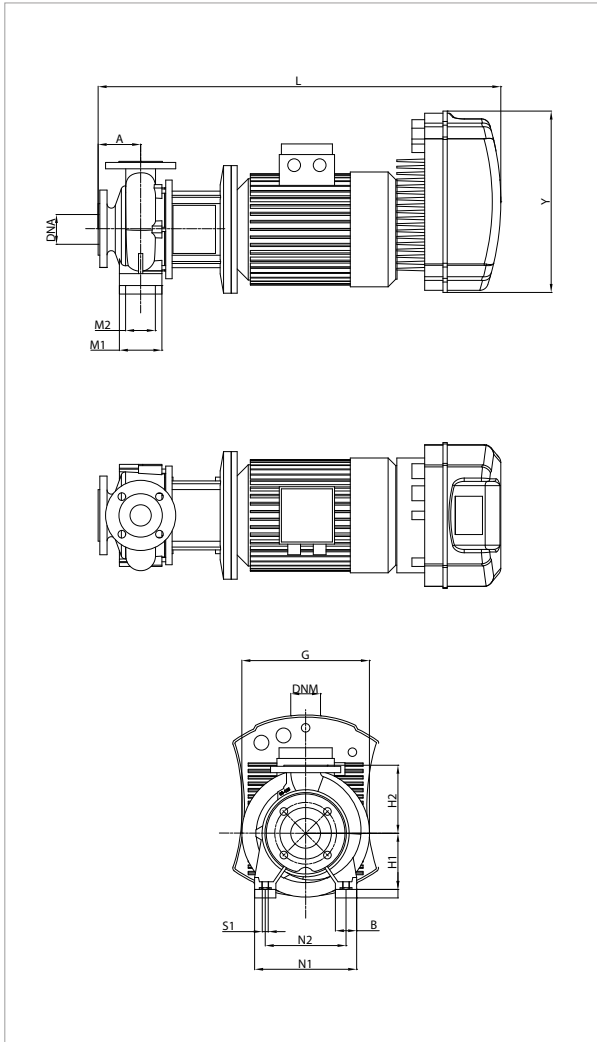

See hydraulic efficiency details on page 241.

The performance curves are based on kinematic viscosity values = 1 mm²/s and density equal to 1000 kg/m³. Curve tolerance according to ISO 9906.

MODEL	MCE MODEL	POWER INPUT 50 Hz	P2 NOMINAL		In A
			kW	HP	
NKP-GE80-160/147-127/A/BAQE/11/2MCE150/P	MCE150/P	3 x 400 ~V	11,00	15,0	24,09

MODEL	A	B	G	H1	H2	L	M1	M2	N1	N2	S1	X	Y	DNA	DNM	PACKING DIMENSIONS			WEIGHT kg
																L/A	L/B	H	
NKP-GE80-160/147-127/A/BAQE/11/2MCE150/P	125	67	350	160	225	1123	-	-	314	254	M12	140	426	100	80	1386	526	676	215

NKP-GE 80-160 - STANDARDISED MONOBLOC CENTRIFUGAL ELECTRIC PUMPS WITH INVERTER FOR CIRCULATION SYSTEMS



Pumped liquid temperature range: from -10 °C to +140 °C (MCE/C) - Maximum ambient temperature: +40 °C

≈ 2900 1/min

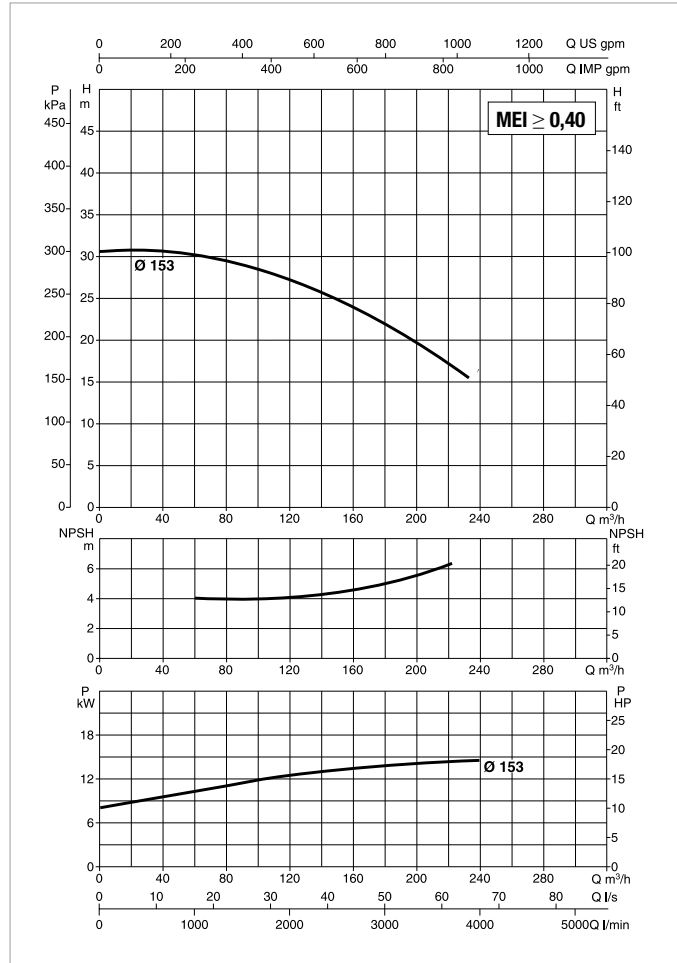
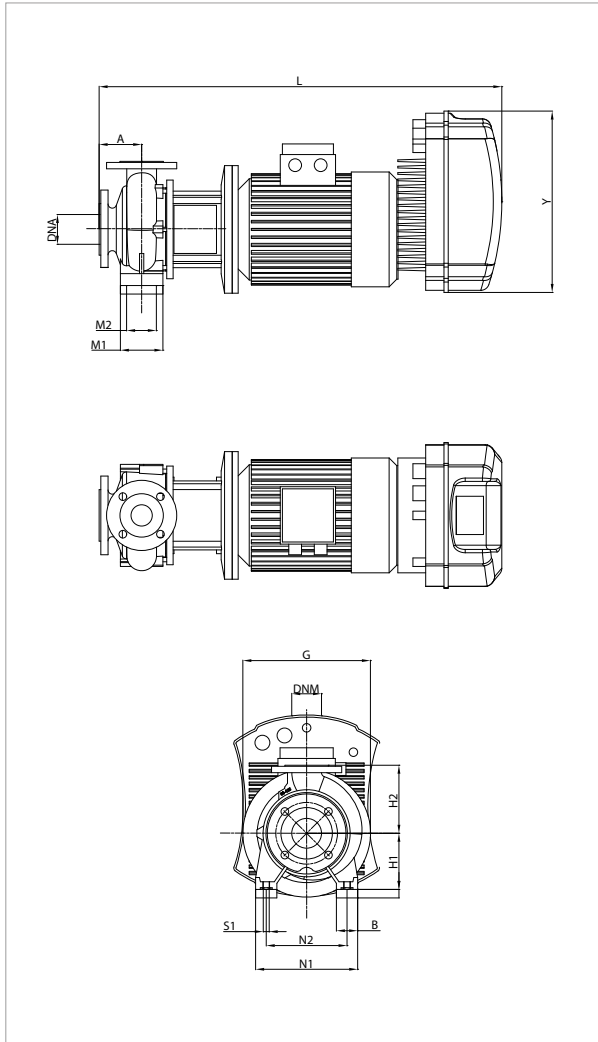

See hydraulic efficiency details on page 241.

The performance curves are based on kinematic viscosity values = 1 mm²/s and density equal to 1000 kg/m³. Curve tolerance according to ISO 9906.

MODEL	MCE MODEL	POWER INPUT 50 Hz	P2 NOMINAL		In A
			kW	HP	
NKP-GE 80-160/153/A/BAQE/15/2 T MCE150/C	MCE150/C	3 x 400 -V	15,00	20,0	32,6

MODEL	A	B	G	H1	H2	L	M1	M2	N1	N2	S1	X	Y	DNA	DNM	PACKING DIMENSIONS			WEIGHT kg
																L/A	L/B	H	
NKP-GE 80-160/153/A/BAQE/15/2 T MCE150/C	125	67	350	160	225	1078	-	-	314	254	M12	140	426	100	80	1360	500	530	221

STANDARDISED CENTRIFUGAL ELECTRIC PUMPS WITH INVERTER



FOR CIRCULATION
SYSTEMS

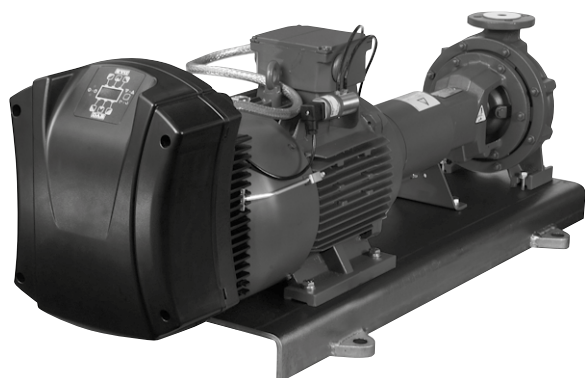

FOR PRESSURIZATION
SYSTEMS

**TECHNICAL DATA**

Rotation speed: 1450 - 2900 1/min.

Operating range:

from 1 to 470 m³/h with head up to 63 metres.

Liquid temperature range:

from -10 °C to +140 °C (MCE/C)

from -10 °C to +80 °C (MCE/P)

Pumped liquid: clean, free of solids and abrasives, non-viscous, non-aggressive, non-crystallised and chemically neutral, with properties similar to water.

Maximum ambient temperature: +40 °C.

Maximum operating pressure:

16 bar - 1600 kPa (for DN 200 max 10 bar).

Protection class: IP 55.

Insulation class: F.

Flanging: PN 16 DIN 2533.

PN 10 DIN 2532 for DN 200.

Installation: normally in the horizontal position.

APPLICATIONS

Standardised centrifugal electronic pumps on base with elastic coupling, designed for a wide range of applications, such as:

MCE/C: Circulation of the hot water of the heating system, of the cold water of the air conditioning and refrigeration systems.

MCE/P: Pressure increase, supply of drinking water and sprinkler and watering systems.

CONSTRUCTION FEATURES OF THE PUMP

Cast iron single stage spiral body complying with DIN-EN 733 (formerly DIN 24255), seal holder cover and cast iron motor support, flanges complying with DIN 2533 (DIN 2532 for DN 200). Cast iron impeller, closed and dynamically balanced, with compensation of the axial thrust through balancing holes, operation on interchangeable wear rings (on request). Stainless steel pump shaft supported by two permanently lubricated oversized ball bearings, housed inside an appropriate chamber in the support.

Standard seal device: standardised mechanical seal according to DIN 24960 in carbon/silicon carbide with EPDM OR rings. Packing with lubricating hydraulic ring and stuffing box in two easily removable parts available on request.

CONSTRUCTION FEATURES OF THE MOTOR

Closed asynchronous type, external ventilation cooling, 2 or 4 poles. Rotor running on ball bearings, largely oversized to ensure low noise and durability. Controlled by MCE inverter.

Construction: B3

Standard single-phase voltage: 1x220-240 V / 50-60 Hz

Special version on request: three-phase 3x400 V / 50 Hz or three-phase 3x460 V / 60 Hz

Standard three-phase voltage: 3x400 V / 50 Hz

Special version on request: 3x460 V / 60 Hz



MCE/C INVERTER

CONSTRUCTION FEATURES OF THE ELECTRONICS: MCE/C INVERTER

MCE/C inverters have been designed for managing circulation pumps. By allowing a simple adjustment of the differential pressure, they give the possibility of adjusting the performance of the circulation pump to the actual system requirements. They are fitted on the fan cover of the motor. This makes the installation of the pump with MCE/C particularly easy and quick. The protection class of the MCE/C is IP55. The easy of programming is guaranteed by the use of a simple and intuitive interface, similar to Dialogue electronic circulators, and a graphic display. MCE/C inverters have a double micro-processor construction that guarantees maximum efficiency and reliability.

MCE/C inverters protect the motor and the pump, and increase their life, by eliminating hammering effects and making the pump rotate at the minimum number of rotations capable of meeting the requirements of the user. In addition, electric pumps controlled by the MCE/C inverter are environmentally friendly. In fact, by ensuring that the pump only uses the power that is strictly necessary for meeting the needs of the users, electricity consumption is strongly reduced when compared with fixed speed pumps. It is possible to create twin units by using the appropriate cable for the connection of MCE/C inverters.

MODES OF OPERATION

All the functions listed below can be consulted by the users (including less experienced ones) by simply scrolling through the MCE/C menu. The calibration and the modification of the parameters are protected, and can only be completed by expert users.

1 - ΔP -c constant differential pressure adjustment mode

The ΔP -c adjustment mode keeps the differential pressure of the system constantly at the H (setp) value set, even in case of variation of the flow rate. This is the standard adjustment used. It can be set directly from the MCE/C control panel. The inverter keeps the differential pressure (H setp) constant even in case of flow variation.

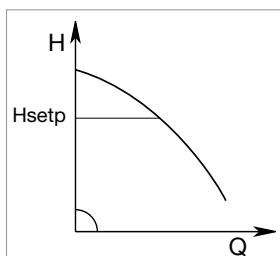

This adjustment is particularly indicated for the following systems:

- a. two-pipe heating systems with thermostat valves**
- b. underfloor heating systems with thermostat valves**
- c. single-pipe heating systems with thermostat valves and calibration valves**
- d. systems with primary circuit pumps**

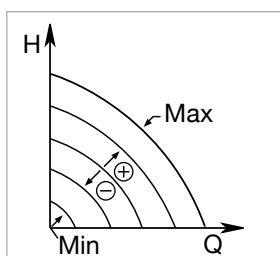

2 - Constant curve adjustment modes

2.1 - Constant curve adjustment

The rotation speed is kept at a constant number of revolutions. This rotation speed can be set between a minimum value and the nominal frequency of the circulation pump (e.g. between 15 Hz and 50 Hz). This mode can be set using the control panel on the MCE cover.

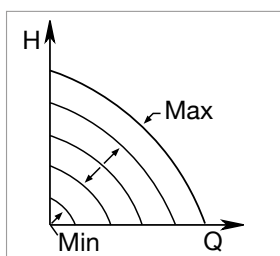

2.2 - Adjustment of the constant curve with external analogue signal

The rotation speed is kept at a constant number of revolution in proportion with the voltage of the external analogue signal.

The rotation speed changes in a linear way, between the nominal frequency of the pump when $V_{in} = 10 V$, and the minimum frequency when $V_{in} = 0 V$.

This mode can be set using the control panel on the MCE cover.

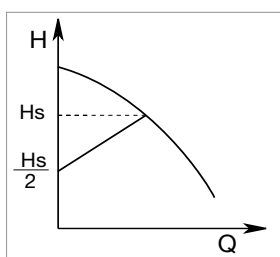

3 - ΔP -v * proportional differential pressure adjustment mode

With ΔP -v adjustment mode, with the variation of the flow rate, the value of the delivery of the head also varies in a linear manner, from H_{setp} to $H_{setp}/2$.

* in order to know the availability of the function on specific models contact our customer service.

For more information refer to the technical appendix.

MCE/P INVERTER

MCE-P

CONSTRUCTION FEATURES OF THE ELECTRONICS: MCE/P INVERTER

The inverter continuously adjusts the rotation speed of the electric pump, keeping the pressure constant, even when the flow rate varies.

The other electric pumps, also with variable speed, are activated in cascade after the first one has reached maximum speed. Through modulation, they compensate the pressure fluctuations of the system.

For every operating cycle, it is possible to switch the restart to a different pump, therefore ensuring even use of all electric pumps.

It is possible to set operation times for each individual pump, switching to another pump after such set times.

The "SP" pressure can be adjusted by the user using the "+" and "-" keys found on the MCE/P (as a rule, all the pumps are set to the same pressure value). With the new MCE/P, it is sufficient to set the data on one of the devices, and it will be automatically propagated to the other pumps of the system.

MODES OF OPERATION

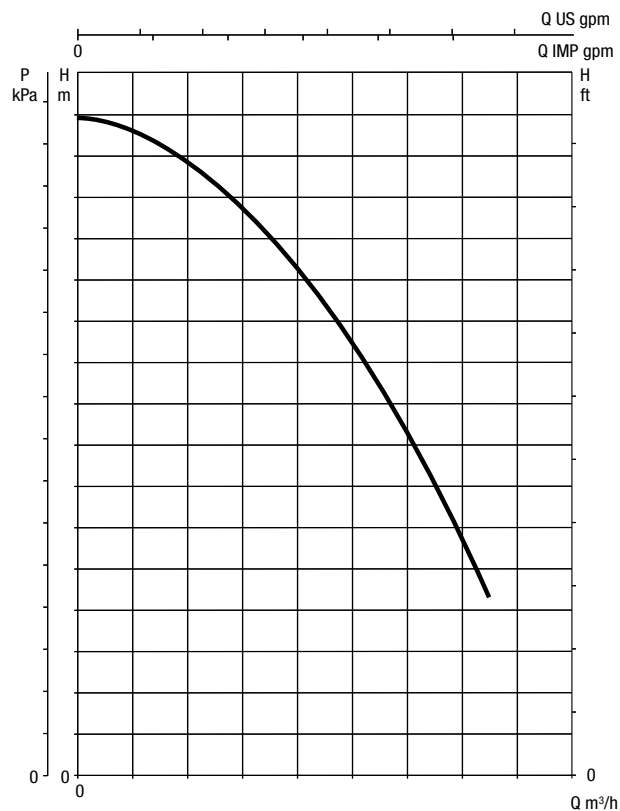

PERFORMANCE CURVES WITHOUT INVERTER

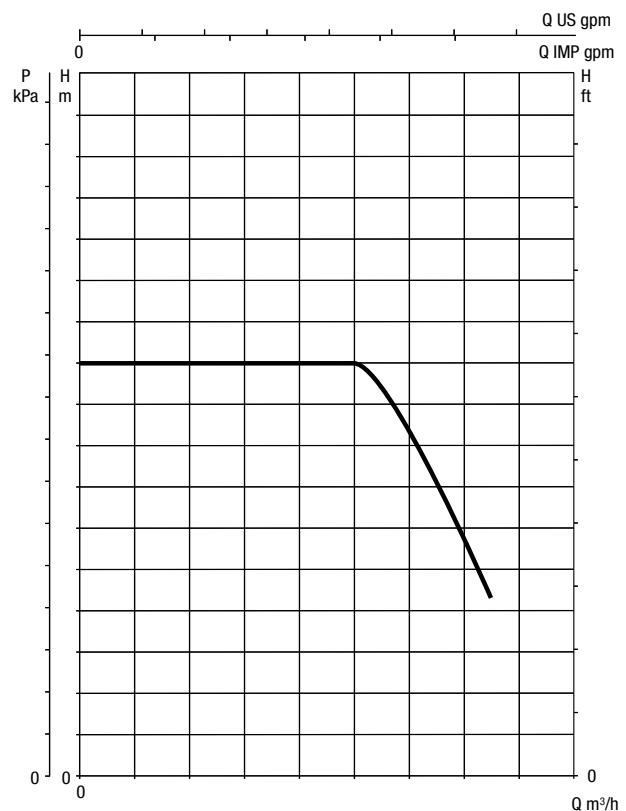

PERFORMANCE CURVES WITH INVERTER

The inverter is capable of maintaining a constant pressure even when the flow rate varies.

The operating pressure can be adjusted by the user.

A good pressure set-point is between 1/3 and 2/3 of the maximum head of the electric pump. In this way, high efficiency of the pump is maintained, together with maximum saving.

In addition, the MCE/P does not block the pump if the pressure is not reached, but the flow is present. This prevents service interruptions in case of high flows.

For more information refer to the technical appendix.

MATERIALS

N.	PARTS*	MATERIALS
1	PUMP BODY	CAST IRON 250 UNI ISO 185
4	IMPELLER	CAST IRON 200 UNI ISO 185
7A	PUMP SHAFT	AISI 420 STAINLESS STEEL UNI 6900/71
28	OR RING	VITON
36	SEAL HOLDING DISC	CAST IRON 250 UNI ISO 185
16	MECHANICAL SEAL	CARBON/SILICON CARBIDE
31	SEAL SPACER	AISI 304 STAINLESS STEEL UNI 6900/71

N.	PARTS*	MATERIALS
58	SEAL BUSHING	AISI 420 STAINLESS STEEL UNI 6900/71
141	HYDRAULIC RING	AISI 304 STAINLESS STEEL UNI 6900/71
142	STUFFING BOX	RAMIE IMPREGNATED PTFE

* In contact with the liquid

STANDARD VERSION WITH MECHANICAL SEAL

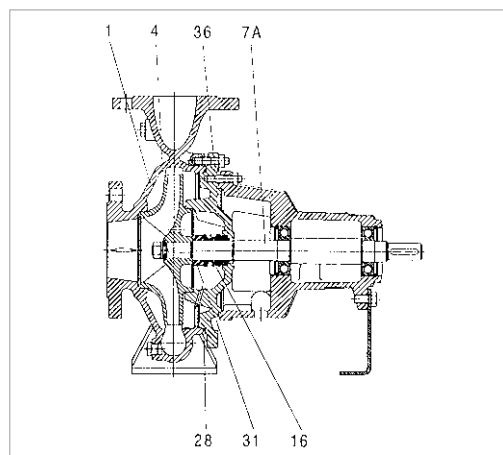

VERSION ON REQUEST WITH PACKING

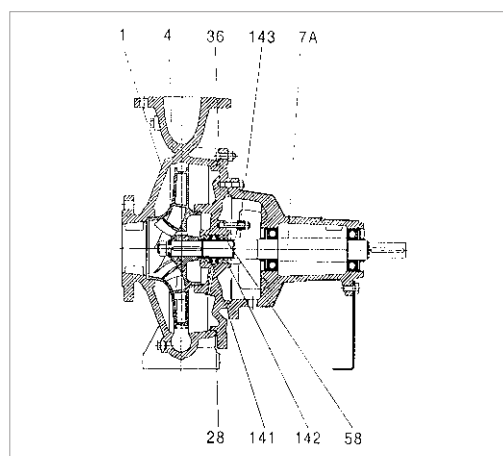

KDNE - 4 POLES

STANDARDISED CENTRIFUGAL ELECTRIC PUMPS WITH INVERTER

SELECTION TABLE - KDNE 32

MODEL	Q=m ³ /h	0	3	6	12	18	24
	Q=l/min	0	50	100	200	300	400
KDNE 32-125.1/140	H (m)	6.6	6.6	6.4	5.1		
KDNE 32-125/142		6.9		6.75	6.15	4.5	
KDNE 32-160.1/177		9	9.8	9.5	6.6		
KDNE 32-160/177		10.5		10.4	9.6	7.8	
KDNE 32-200.1/207		13.8	13.8	13	8.9		
KDNE 32-200/200		12.6		12.3	11.1	8.7	
KDNE 32-200/219		15.7		15.4	14.8	13	9.8

SELECTION TABLE - KDNE 40

MODEL	Q=m ³ /h	0	6	12	18	24	30	36
	Q=l/min	0	100	200	300	400	500	600
KDNE 40-125/142	H (m)	6.7	6.6	6.5	6	5.3	4.1	
KDNE 40-160/161		8.6	8.5	8.4	8	7.1	5.6	
KDNE 40-160/177		10.7	10.7	10.6	10.2	9.5	8.3	
KDNE 40-200/180		9.7	9.7	9.4	8.8	7.2		
KDNE 40-200/200		12.2	12.1	12	11.7	10.4	8.6	
KDNE 40-200/219		15	15	15	14.7	13.8	12.4	10.4
KDNE 40-250/230		17.4		17.2	16.5	15.3	13.7	
KDNE 40-250/240		19.1		19	18.2	17	15.5	
KDNE 40-250/250		20.7		20.6	20	18.9	17.5	
KDNE 40-250/260		22.7		22.6	22.1	21	19.5	

SELECTION TABLE - KDNE 50

MODEL	Q=m ³ /h	0	12	18	24	30	36	42	48	54
	Q=l/min	0	200	300	400	500	600	700	800	900
KDNE 50-125/139	H (m)	6.3	6.2	6.1	5.9	5.6	5.2	4.8	4.2	
KDNE 50-125/144		6.7	6.7	6.6	6.4	6.2	5.8	5.3	4.8	4.1
KDNE 50-160/137		6	6	5.9	5.6	5.2	4.8			
KDNE 50-160/153		7.6	7.6	7.5	7.4	7.2	6.7			
KDNE 50-160/169		9.4	9.3	9.2	9.2	9.1	8.8			
KDNE 50-160/177		10.4	10.3	10.3	10.2	10.1	9.95			
KDNE 50-200/170		9.5	9.3	9.2	8.8	8	6.85			
KDNE 50-200/190		11.8	11.7	11.6	11.4	10.8	10.1	8.9		
KDNE 50-200/210		14.6	14.6	14.5	14.4	13.9	13.2	12.2	11	
KDNE 50-200/219		16	16	16	15.9	15.4	14.2	13.8	12.7	11.4
KDNE 50-250/220		15.9	15.7	15.6	15.4	14.9	13.8	12.4	10.5	xxx
KDNE 50-250/263		23	23	22.9	22.8	22.5	21.7	20.6	19.4	17.5

KDNE - 4 POLES

STANDARDISED CENTRIFUGAL ELECTRIC PUMPS WITH INVERTER

SELECTION TABLE - KDNE 65

MODEL	Q=m ³ /h	0	18	24	30	36	42	48	54	60	66	72	78	84	90	102	114	
	Q=l/min	0	300	400	500	600	700	800	900	1000	1100	1200	1300	1400	1500	1700	1900	
KDNE 65-125/130	H (m)	5.1		4.9	4.75	4.6	4.3	4.1	3.8	3.3	2.8							
KDNE 65-125/144		6.4		6.35	6.25	6.2	5.9	5.7	5.4	5	4.65	4.2	3.7					
KDNE 65-160/137		5.8		5.7	5.4	5.2	4.75	4.3	3.7									
KDNE 65-160/153		7.3		7.2	7.2	6.9	6.7	6.3	5.8	5.25								
KDNE 65-160/169		9.1		9.1	9	8.9	8.7	8.4	8	7.6	7.1	6.4						
KDNE 65-160/177		10		10	9.9	9.8	9.7	9.45	9.1	8.7	8.2	7.5						
KDNE 65-200/180		10.4	10.4	10.4	10.3	10.2	10	9.5	8.8	8.1								
KDNE 65-200/190		12.1	12	12	12	11.9	11.5	11.1	10.5	9.8	8.8							
KDNE 65-250/240		19		19	18.9	18.5	18.1	17.5	16.8	16	14.7	13.6						
KDNE 65-250/263		23.2		23	23	22.9	22.5	22.2	21.6	20.8	19.8	18.6	17.4	16				
KDNE 65-315/260		22.3		22.2	22.1	22	21.5	21	20.5	20	19.2	18.4	17	16	15			
KDNE 65-315/290		28.2		28.2	28.1	28	27.8	27.3	27	26.5	25.5	25	24	23.1	22	19.5		
KDNE 65-315/320		35.7		35.4	35.3	35.2	35.1	35	34.8	34.5	33.8	33.5	32.5	31.5	30.8	28	24.8	

SELECTION TABLE - KDNE 80

MODEL	Q=m ³ /h	0	42	48	54	60	66	72	78	84	90	102	114	120	150	180	
	Q=l/min	0	700	800	900	1000	1100	1200	1300	1400	1500	1700	1900	2000	2500	3000	
KDNE 80-160/153	H (m)	7.3	7.1	6.9	6.7	6.5	6.3	6	5.75	5.4	5.2	4.55	3.9	3.6			
KDNE 80-160/161		8.2	8	7.9	7.75	7.5	7.3	7.05	6.8	6.5	6.25	5.6	4.9	4.6			
KDNE 80-160/177		10	9.9	9.85	9.8	9.7	9.5	9.3	9.1	8.85	8.7	8.1	7.25	6.9			
KDNE 80-200/170		9.2	9.1	9	8.7	8.5	8.2	7.8	7.5	7.1	6.7	5.6					
KDNE 80-200/200		12.7	12.6	12.6	12.6	12.5	12.4	12.3	12	11.6	11.4	10.5	9.4	8.8			
KDNE 80-200/222		15.9	15.9	15.8	15.7	15.6	15.6	15.5	15.4	15.3	15	14.3	13.4	12.8			
KDNE 80-250/230		17.3	17.3	17.2	17.1	17	16.9	16.8	16.5	16	15.5	14.3	12.4				
KDNE 80-250/260		22.6	22.5	22.5	22.4	22.3	22.2	22.1	22	21.8	21.4	20.6	19.6	19	15.1		
KDNE 80-250/270		24.5	24.4	24.4	24.4	24.3	24.2	24.1	24	23.7	23.3	22.4	21.4	20.7	16.3		
KDNE 80-315/290		27.8		27.8	27.8	27.7	27.7	27.6	27.6	27.5	27.4	26.5	25	24.6	19.1		

SELECTION TABLE - KDNE 100

MODEL	Q=m ³ /h	0	60	66	72	78	84	90	102	114	120	150	180	210	240	
	Q=l/min	0	1000	1100	1200	1300	1400	1500	1700	1900	2000	2500	3000	3500	4000	
KDNE 100-200/180	H (m)	10.1	10.1	10.1	10	9.9	9.7	9.5	9.1	8.5	8.3	7	5.4			
KDNE 100-200/200		12.9	12.8	12.8	12.8	12.7	12.6	12.5	12.2	11.8	11.6	10.4	8.8			
KDNE 100-200/219		16	15.7	15.7	15.6	15.6	15.5	15.5	15.3	15.1	15	14	12.5	10.8		
KDNE 100-250/240		18.5	18.3	18.3	18.3	18.2	18.1	18	17.9	17.6	17.4	15.7	13.3			
KDNE 100-250/260		22.3	22.1	22.1	22.1	22	21.9	21.8	21.7	21.5	21.4	19.8	17.7	15.1		
KDNE 100-315/275		25.1	25	25	25	24.9	24.8	24.7	24.6	24.4	24	22	19			

SELECTION TABLE - KDNE 125

MODEL	Q=m ³ /h	0	102	114	120	150	180	210	240	270	300	330	360	390	420
	Q=l/min	0	1700	1900	2000	2500	3000	3500	4000	4500	5000	5500	6000	6500	7000
KDNE 125-250/230	H (m)	16.6	16.6	16.6	16.5	16.3	15.6	14.8	13.8	12.5	12.3	9.5			

SELECTION TABLE - KDNE 150

MODEL	Q=m ³ /h	0	102	114	120	150	180	210	240	270	300	330	360	390	420
	Q=l/min	0	1700	1900	2000	2500	3000	3500	4000	4500	5000	5500	6000	6500	7000
KDNE 150-200/218	H (m)	12.9	12.7	12.7	12.6	12.4	12.1	11.7	11.2	10.7	10.2	9.6	8.8	8	7.1
KDNE 150-200/224		13.8	13.6	13.6	13.5	13.3	13	12.6	12.2	11.7	11.2	10.6	9.9	9.2	8.2

KDNE 32-125.1 - 4 POLES - STANDARDISED CENTRIFUGAL ELECTRIC PUMPS WITH INVERTER FOR CIRCULATION SYSTEMS



Pumped liquid temperature range: from -10 °C to +140 °C (MCE/C) - Maximum ambient temperature: +40 °C

= 1450 1/min

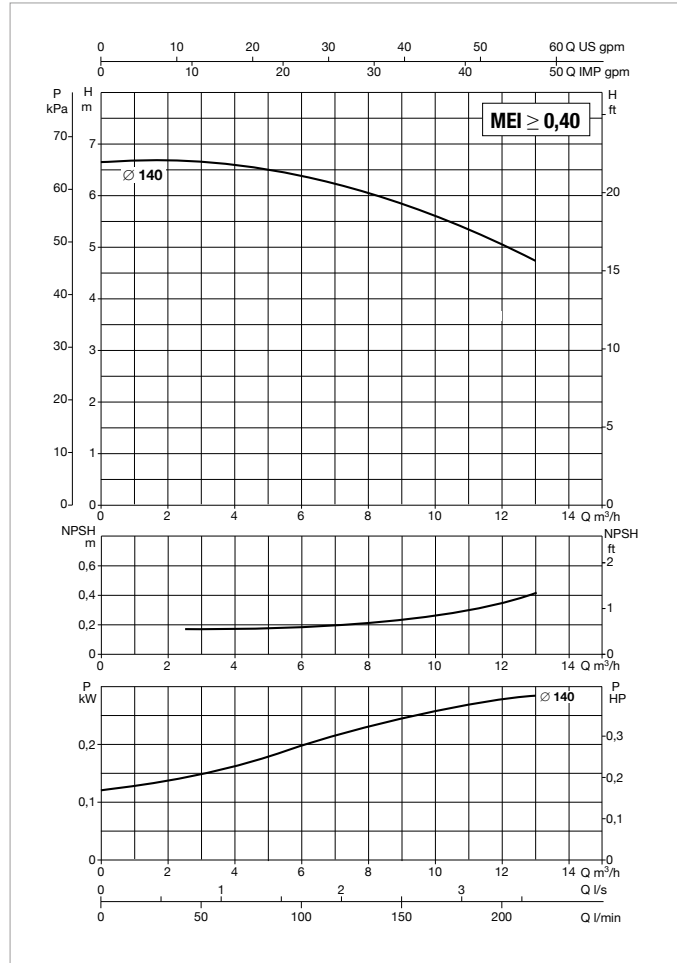
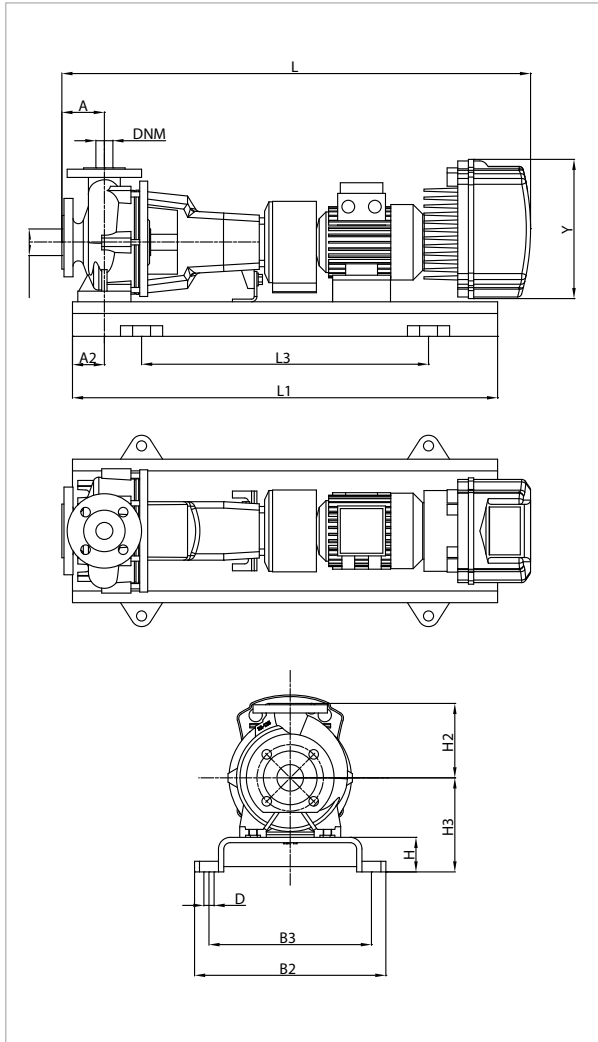

See hydraulic efficiency details on page 241.

The performance curves are based on kinematic viscosity values = 1 mm²/s and density equal to 1000 kg/m³. Curve tolerance according to ISO 9906.

MODEL	MCE MODEL	POWER INPUT 50 Hz	P2 NOMINAL		In A
			kW	HP	
KDNE 32-125.1/140/A/BAQE/1/0,55/4 M MCE11/C	MCE11/C	1 x 230 ~V	0,55	0,75	7,1
KDNE 32-125.1/140/A/BAQE/1/0,55/4 T MCE30/C	MCE30/C	3 x 400 ~V	0,55	0,75	7,4

MODEL	A	A2	H2	H	H3	L1	L3	B2	B3	D	Y	FLANGE DIMENSIONS (mm)		STANDARD COUPLING		SPACER COUPLING	
												DNA	DNM	L	WEIGHT kg	L	WEIGHT kg
												KDNE 32-125.1/140/A/BAQE/1/0,55/4 M MCE11/C	80	60	140	65	177
KDNE 32-125.1/140/A/BAQE/1/0,55/4 T MCE30/C	80	60	140	65	177	800	540	360	320	19	353	50	32	1004	89,6	1104	94,6

KDNE 32-125 - 4 POLES - STANDARDISED CENTRIFUGAL ELECTRIC PUMPS WITH INVERTER FOR CIRCULATION SYSTEMS



Pumped liquid temperature range: from -10 °C to +140 °C (MCE/C) - Maximum ambient temperature: +40 °C

= 1450 1/min

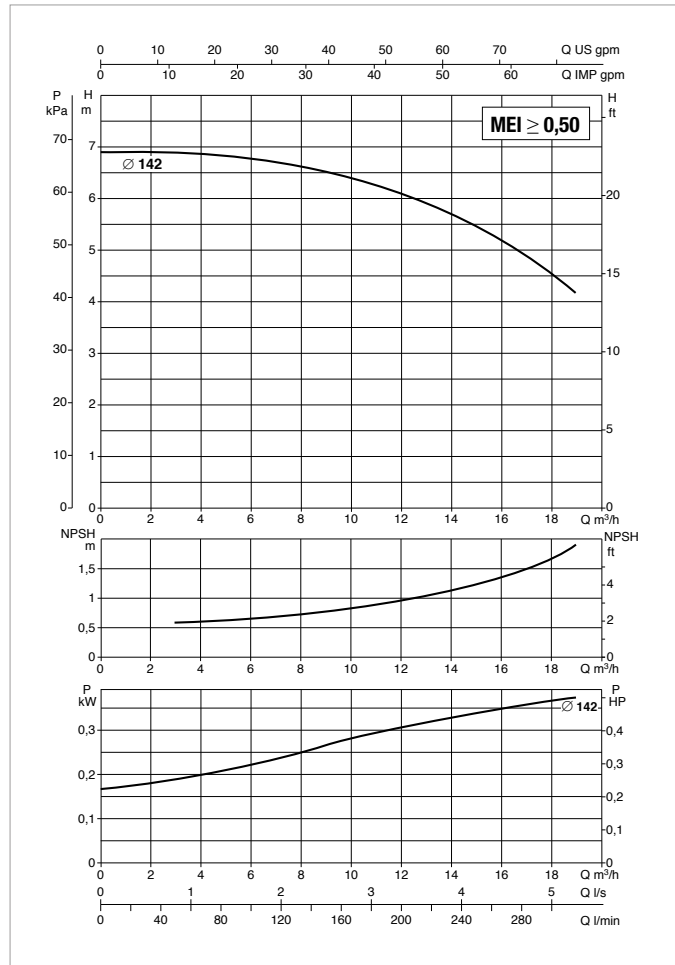
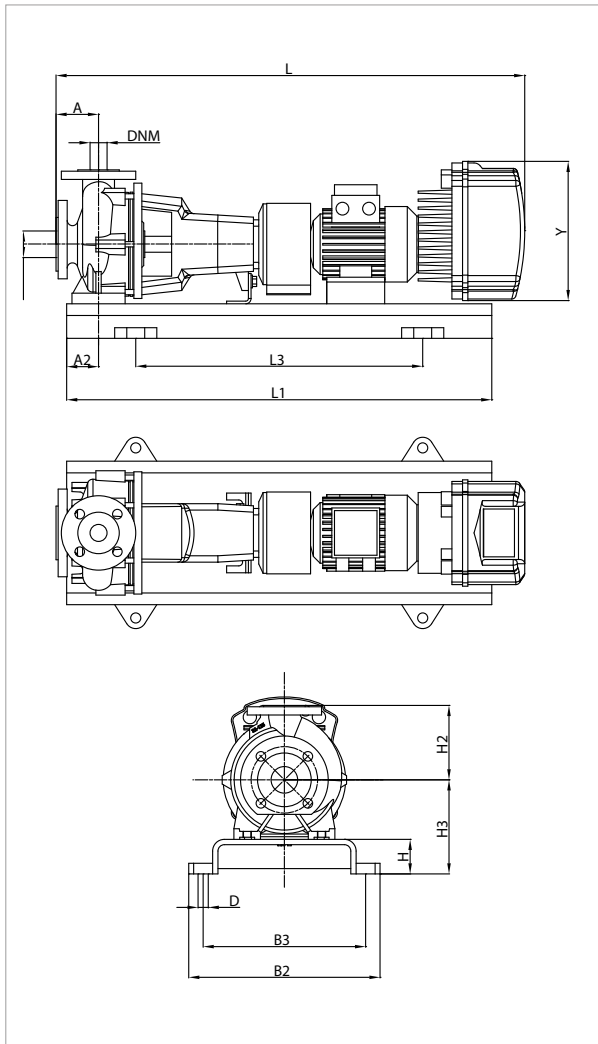

See hydraulic efficiency details on page 241.

The performance curves are based on kinematic viscosity values = 1 mm²/s and density equal to 1000 kg/m³. Curve tolerance according to ISO 9906.

MODEL	MCE MODEL	POWER INPUT 50 Hz	P2 NOMINAL		In A
			kW	HP	
KDNE 32-125/142/A/BAQE/1/0,75/4 M MCE11/C	MCE11/C	1 x 230 ~V	0,75	1	8,2
KDNE 32-125/142/A/BAQE/1/0,75/4 T MCE30/C	MCE30/C	3 x 400 ~V	0,75	1	2,6

MODEL	A	A2	H2	H	H3	L1	L3	B2	B3	D	Y	FLANGE DIMENSIONS (mm)		STANDARD COUPLING		SPACER COUPLING	
												DNA	DNM	L	WEIGHT kg	L	WEIGHT kg
												KDNE 32-125/142/A/BAQE/1/0,75/4 M MCE11/C	80	60	140	65	177
KDNE 32-125/142/A/BAQE/1/0,75/4 T MCE30/C	80	60	140	65	177	800	540	360	320	19	353	50	32	1004	90,6	1104	95,6

KDNE 32-160.1 - 4 POLES - STANDARDISED CENTRIFUGAL ELECTRIC PUMPS WITH INVERTER FOR CIRCULATION SYSTEMS



Pumped liquid temperature range: from -10 °C to +140 °C (MCE/C) - Maximum ambient temperature: +40 °C

= 1450 1/min

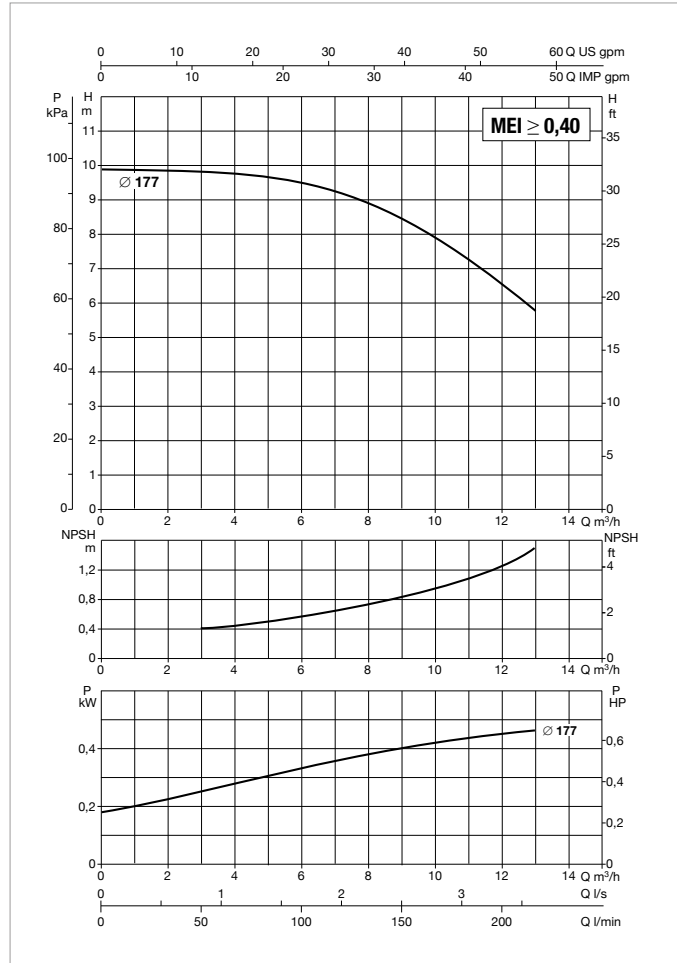
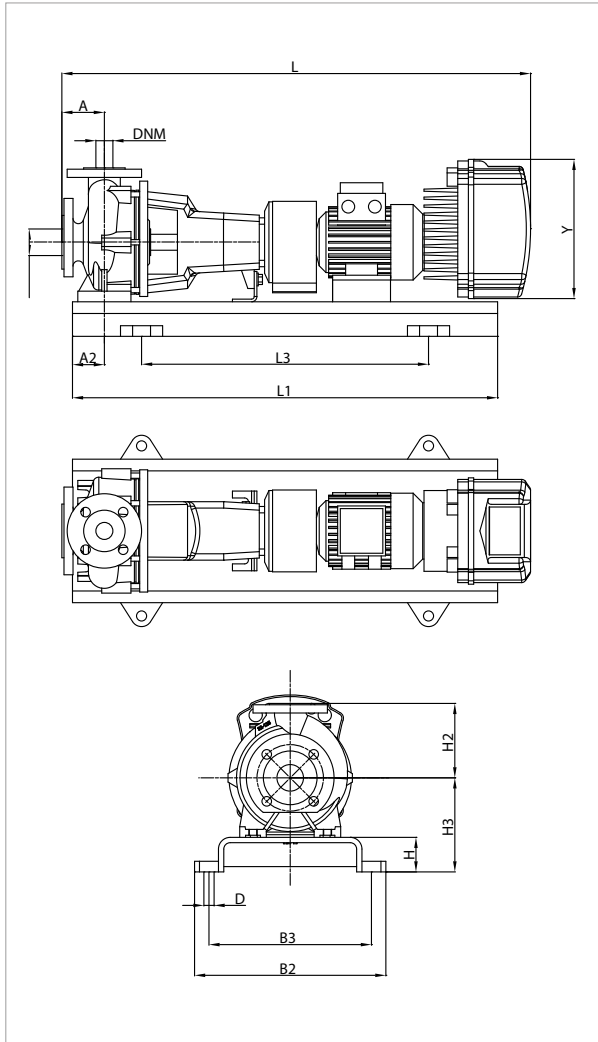

See hydraulic efficiency details on page 241.

The performance curves are based on kinematic viscosity values = 1 mm²/s and density equal to 1000 kg/m³. Curve tolerance according to ISO 9906.

MODEL	MCE MODEL	POWER INPUT 50 Hz	P2 NOMINAL		In A
			kW	HP	
KDNE 32-160.1/177/A/BAQE/1/0,75/4 M MCE11/C	MCE11/C	1 x 230 ~V	0,75	1	8,2
KDNE 32-160.1/177/A/BAQE/1/0,75/4 T MCE30/C	MCE30/C	3 x 400 ~V	0,75	1	2,6

MODEL	A	A2	H2	H	H3	L1	L3	B2	B3	D	Y	FLANGE DIMENSIONS (mm)		STANDARD COUPLING		SPACER COUPLING	
												DNA	DNM	L	WEIGHT kg	L	WEIGHT kg
KDNE 32-160.1/177/A/BAQE/1/0,75/4 M MCE11/C	80	60	160	65	197	800	540	360	320	19	262	50	32	937	90	1037	95
KDNE 32-160.1/177/A/BAQE/1/0,75/4 T MCE30/C	80	60	160	65	197	800	540	360	320	19	353	50	32	1004	92,6	1104	97,6

KDNE 32-160 - 4 POLES - STANDARDISED CENTRIFUGAL ELECTRIC PUMPS WITH INVERTER FOR CIRCULATION SYSTEMS



Pumped liquid temperature range: from -10 °C to +140 °C (MCE/C) - Maximum ambient temperature: +40 °C

= 1450 1/min

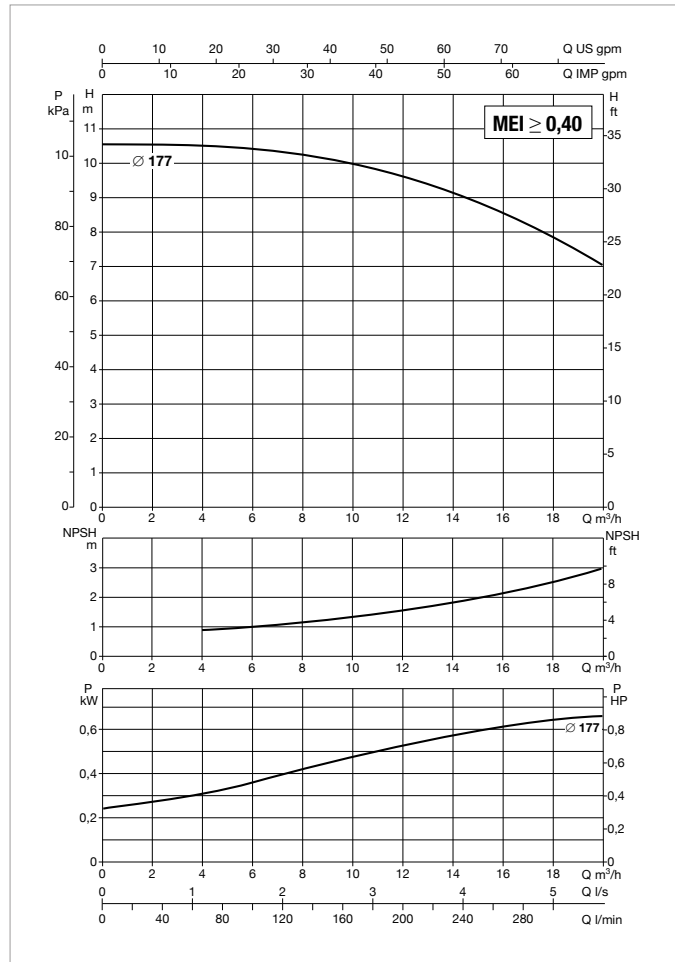
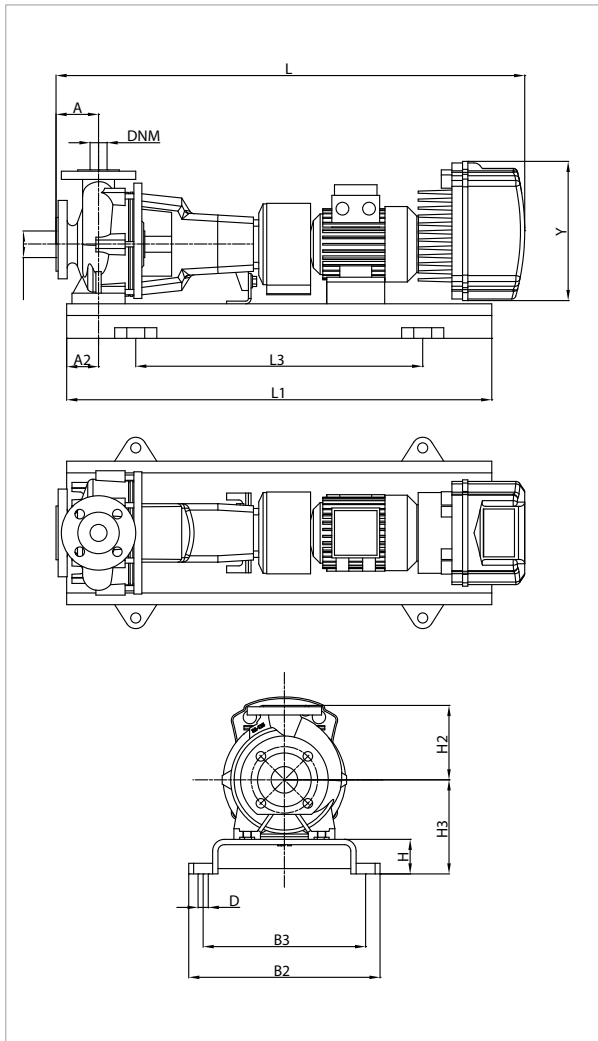

See hydraulic efficiency details on page 241.

The performance curves are based on kinematic viscosity values = 1 mm²/s and density equal to 1000 kg/m³. Curve tolerance according to ISO 9906.

MODEL	MCE MODEL	POWER INPUT 50 Hz	P2 NOMINAL		In A
			kW	HP	
KDNE 32-160/177/A/BAQE/1/1,1/4 M MCE11/C	MCE11/C	1 x 230 ~V	1,1	1,5	10,9
KDNE 32-160/177/A/BAQE/1/1,1/4 T MCE30/C	MCE30/C	3 x 400 ~V	1,1	1,5	3,4

MODEL	A	A2	H2	H	H3	L1	L3	B2	B3	D	Y	FLANGE DIMENSIONS (mm)		STANDARD COUPLING		SPACER COUPLING	
												DNA	DNM	L	WEIGHT kg	L	WEIGHT kg
												KDNE 32-160/177/A/BAQE/1/1,1/4 M MCE11/C	80	60	160	65	197
KDNE 32-160/177/A/BAQE/1/1,1/4 T MCE30/C	80	60	160	65	197	800	540	360	320	19	353	50	32	1056	94,2	1156	99,6

KDNE 32-200.1 - 4 POLES - STANDARDISED CENTRIFUGAL ELECTRIC PUMPS WITH INVERTER FOR CIRCULATION SYSTEMS



Pumped liquid temperature range: from -10 °C to +140 °C (MCE/C) - Maximum ambient temperature: +40 °C

= 1450 1/min

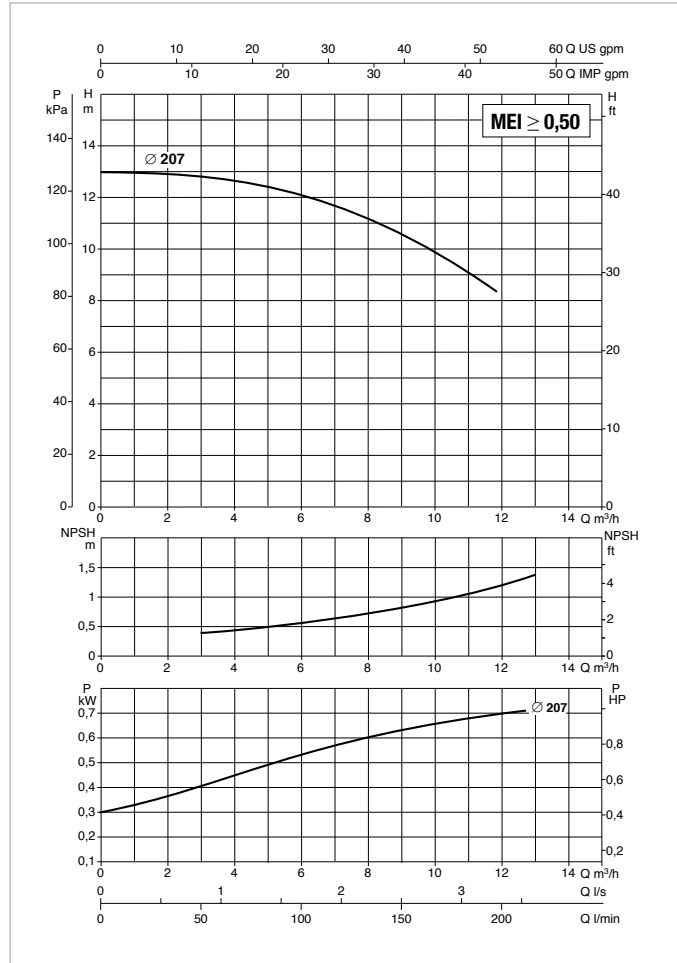
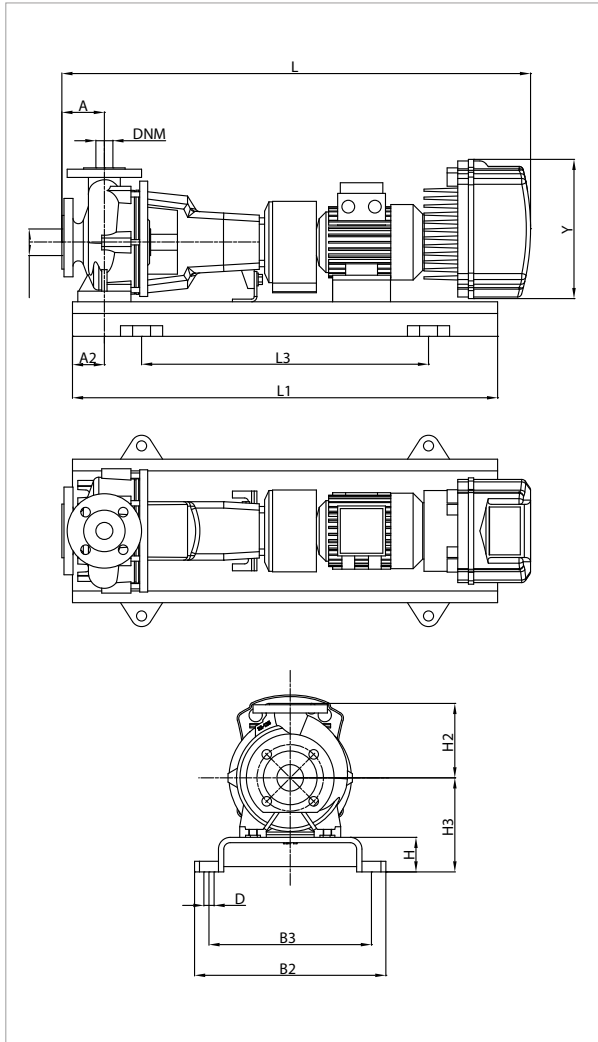

See hydraulic efficiency details on page 241.

The performance curves are based on kinematic viscosity values = 1 mm²/s and density equal to 1000 kg/m³. Curve tolerance according to ISO 9906.

MODEL	MCE MODEL	POWER INPUT 50 Hz	P2 NOMINAL		In A
			kW	HP	
KDNE 32-200.1/207/A/BAQE/1/1,1/4 M MCE11/C	MCE11/C	1 x 230 ~V	1,1	1,5	10,9
KDNE 32-200.1/207/A/BAQE/1/1,1/4 T MCE30/C	MCE30/C	3 x 400 ~V	1,1	1,5	3,4

MODEL	A	A2	H2	H	H3	L1	L3	B2	B3	D	Y	FLANGE DIMENSIONS (mm)		STANDARD COUPLING		SPACER COUPLING	
												DNA	DNM	L	WEIGHT kg	L	WEIGHT kg
												KDNE 32-200.1/207/A/BAQE/1/1,1/4 M MCE11/C	80	60	180	65	225
KDNE 32-200.1/207/A/BAQE/1/1,1/4 T MCE30/C	80	60	180	65	225	800	540	360	320	19	353	50	32	1056	112,6	1156	117,6

KDNE 32-200 - 4 POLES - STANDARDISED CENTRIFUGAL ELECTRIC PUMPS WITH INVERTER FOR CIRCULATION SYSTEMS



Pumped liquid temperature range: from -10 °C to +140 °C (MCE/C) - Maximum ambient temperature: +40 °C

= 1450 1/min

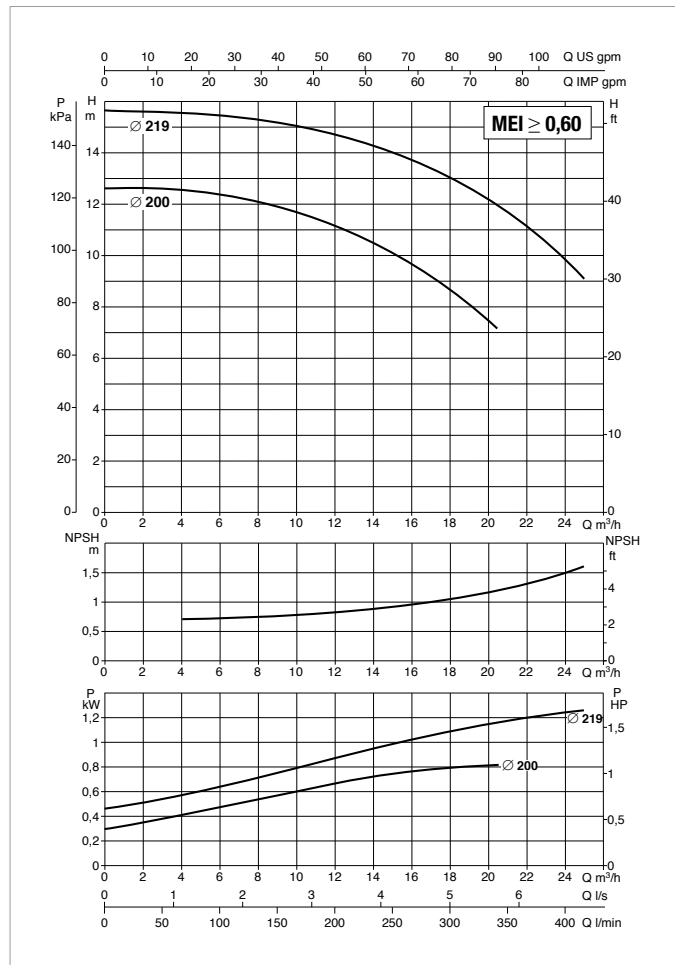
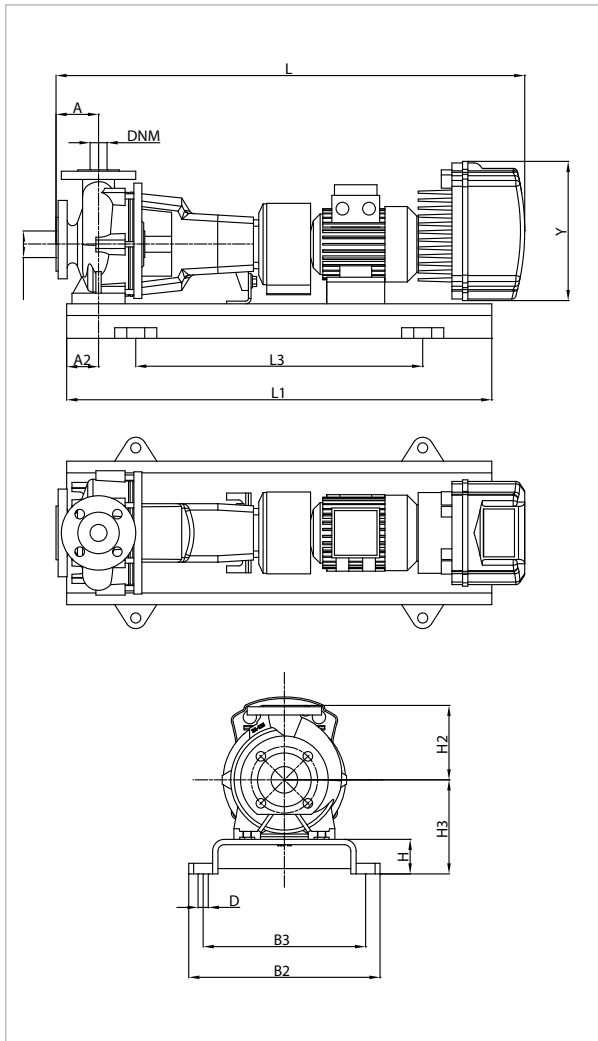

See hydraulic efficiency details on page 241.

The performance curves are based on kinematic viscosity values = 1 mm²/s and density equal to 1000 kg/m³. Curve tolerance according to ISO 9906.

MODEL	MCE MODEL	POWER INPUT 50 Hz	P2 NOMINAL		In A
			kW	HP	
KDNE 32-200/200/A/BAQE/1/1,1/4 M MCE11/C	MCE11/C	1 x 230 ~V	1,1	1,5	10,9
KDNE 32-200/200/A/BAQE/1/1,1/4 T MCE30/C	MCE30/C	3 x 400 ~V	1,1	1,5	3,4
KDNE 32-200/219/A/BAQE/1/2,2/4 M MCE22/C	MCE22/C	1 x 230 ~V	2,2	3	19,7
KDNE 32-200/219/A/BAQE/1/2,2/4 T MCE30/C	MCE30/C	3 x 400 ~V	2,2	3	6,4

MODEL	A	A2	H2	H	H3	L1	L3	B2	B3	D	Y	FLANGE DIMENSIONS (mm)		STANDARD COUPLING		SPACER COUPLING	
												DNA	DNM	L	WEIGHT kg	L	WEIGHT kg
												KDNE 32-200/200/A/BAQE/1/1,1/4 M MCE11/C	80	60	180	65	225
KDNE 32-200/200/A/BAQE/1/1,1/4 T MCE30/C	80	60	180	65	225	800	540	360	320	19	353	50	32	1056	17,6	1156	112,6
KDNE 32-200/219/A/BAQE/1/2,2/4 M MCE22/C	80	60	180	65	225	900	600	390	350	19	262	50	32	1026	106	1126	111
KDNE 32-200/219/A/BAQE/1/2,2/4 T MCE30/C	80	60	180	65	225	900	600	390	350	19	353	50	32	1093	108,6	1193	113,6

KDNE 40-125 - 4 POLES - STANDARDISED CENTRIFUGAL ELECTRIC PUMPS WITH INVERTER FOR CIRCULATION SYSTEMS



Pumped liquid temperature range: from -10 °C to +140 °C (MCE/C) - Maximum ambient temperature: +40 °C

= 1450 1/min

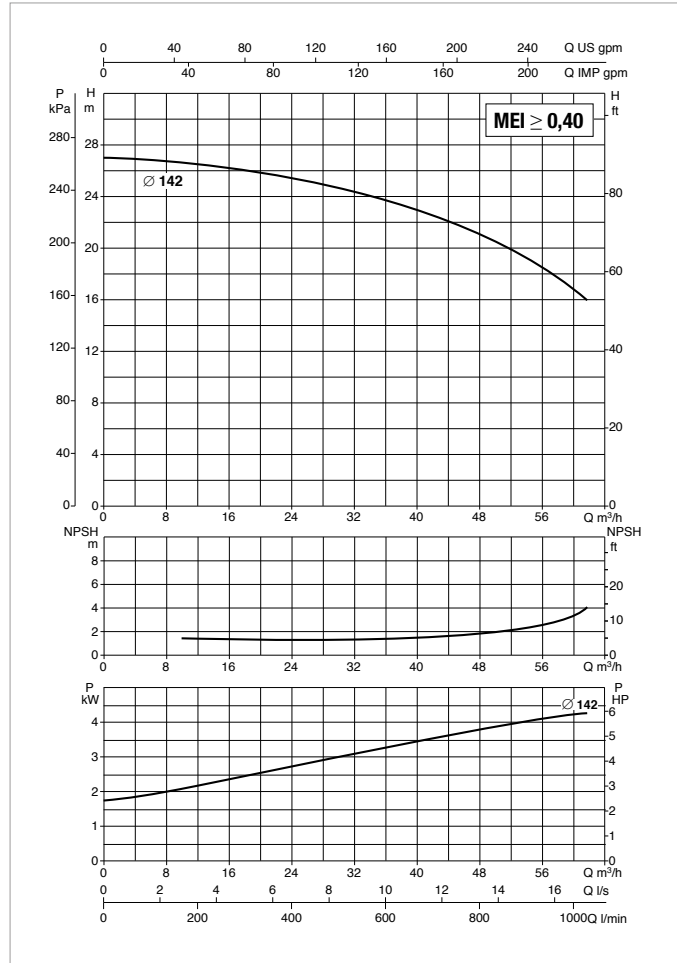
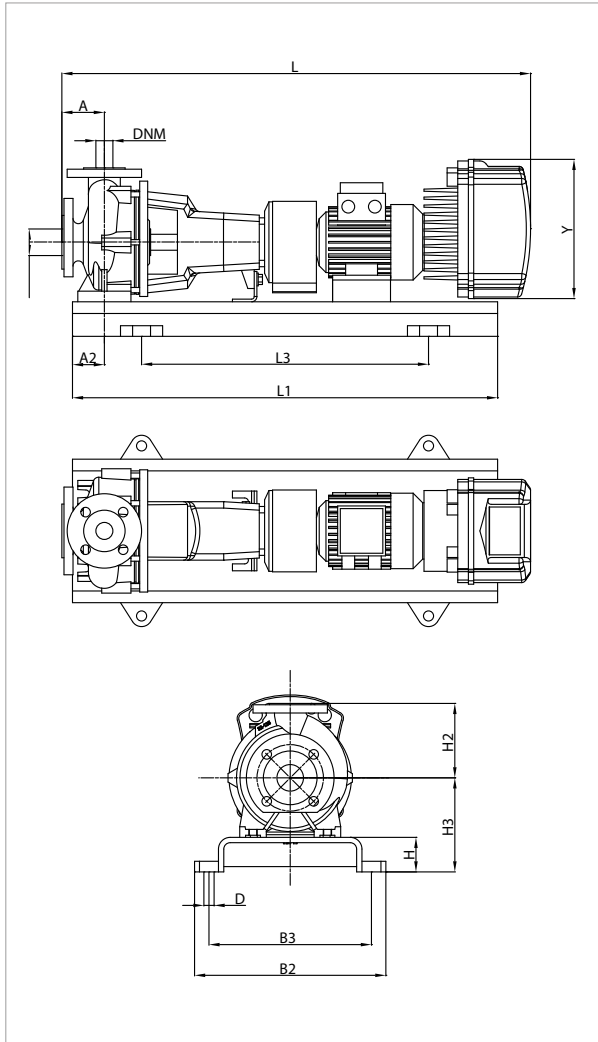

See hydraulic efficiency details on page 241.

The performance curves are based on kinematic viscosity values = 1 mm²/s and density equal to 1000 kg/m³. Curve tolerance according to ISO 9906.

MODEL	MCE MODEL	POWER INPUT 50 Hz	P2 NOMINAL		In A
			kW	HP	
KDNE 40-125/142/A/BAQE/1/1,1/4 M MCE11/C	MCE11/C	1 x 230 ~V	1,1	1,5	10,9
KDNE 40-125/142/A/BAQE/1/1,1/4 T MCE30/C	MCE30/C	3 x 400 ~V	1,1	1,5	3,4

MODEL	A	A2	H2	H	H3	L1	L3	B2	B3	D	Y	FLANGE DIMENSIONS (mm)		STANDARD COUPLING		SPACER COUPLING	
												DNA	DNM	L	WEIGHT kg	L	WEIGHT kg
												KDNE 40-125/142/A/BAQE/1/1,1/4 M MCE11/C	80	60	140	65	177
KDNE 40-125/142/A/BAQE/1/1,1/4 T MCE30/C	80	60	140	65	177	800	540	360	320	19	353	65	40	1056	92,6	1156	97,6

KDNE 40-160 - 4 POLES - STANDARDISED CENTRIFUGAL ELECTRIC PUMPS WITH INVERTER FOR CIRCULATION SYSTEMS



Pumped liquid temperature range: from -10 °C to +140 °C (MCE/C) - Maximum ambient temperature: +40 °C

= 1450 1/min

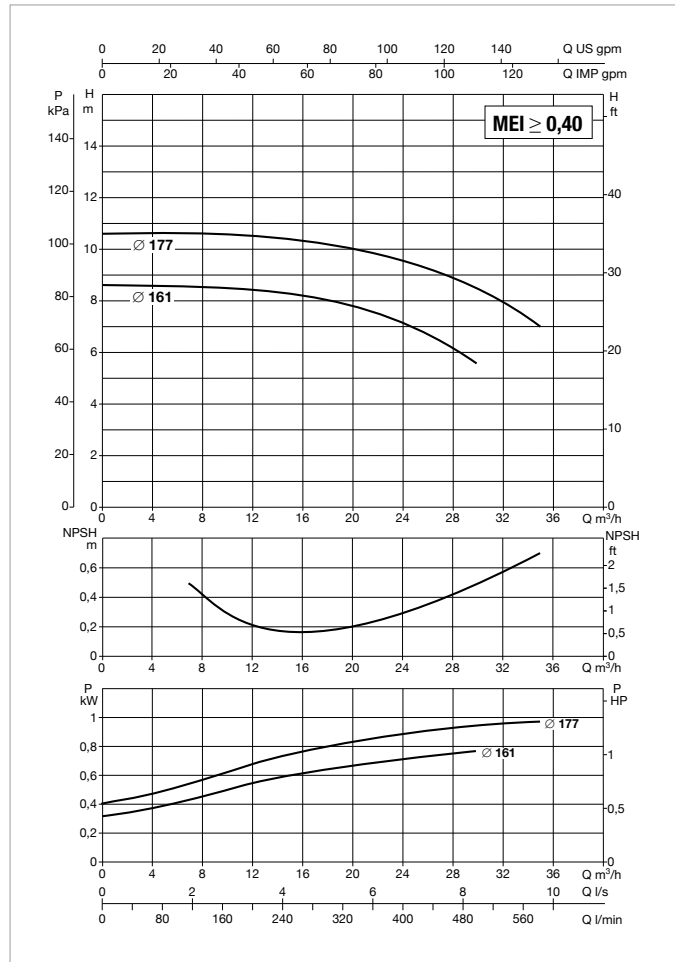
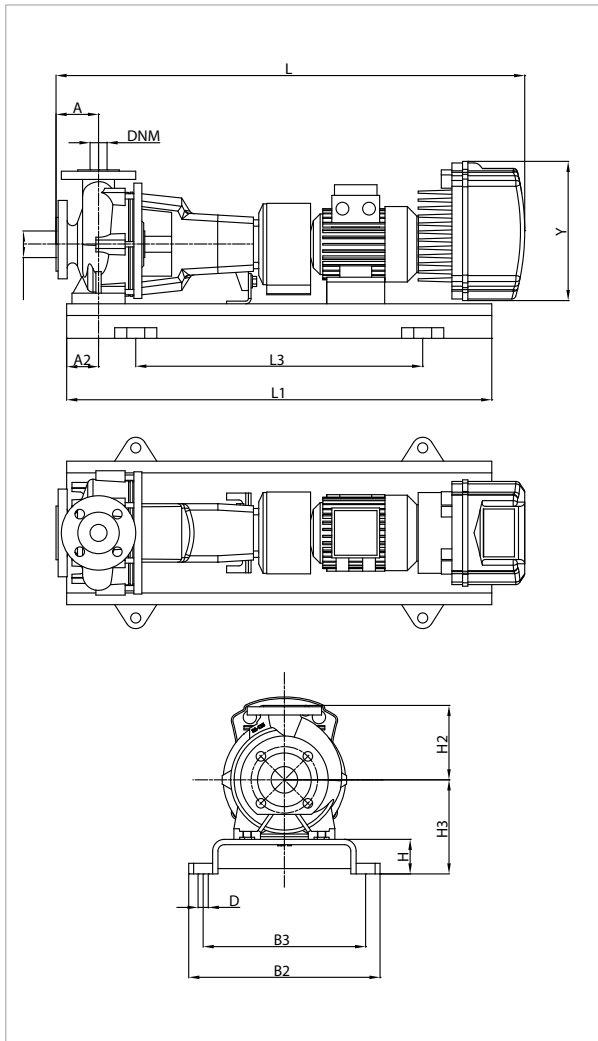

See hydraulic efficiency details on page 241.

The performance curves are based on kinematic viscosity values = 1 mm²/s and density equal to 1000 kg/m³. Curve tolerance according to ISO 9906.

MODEL	MCE MODEL	POWER INPUT 50 Hz	P2 NOMINAL		In A
			kW	HP	
KDNE 40-160/161/A/BAQE/1/1,1/4 M MCE11/C	MCE11/C	1 x 230 ~V	1,1	1,5	10,9
KDNE 40-160/161/A/BAQE/1/1,1/4 T MCE30/C	MCE30/C	3 x 400 ~V	1,1	1,5	3,4
KDNE 40-160/177/A/BAQE/1/1,5/4 M MCE15/C	MCE15/C	1 x 230 ~V	1,5	2	14,1
KDNE 40-160/177/A/BAQE/1/1,5/4 T MCE30/C	MCE30/C	3 x 400 ~V	1,5	2	4,5

MODEL	A	A2	H2	H	H3	L1	L3	B2	B3	D	Y	FLANGE DIMENSIONS (mm)		STANDARD COUPLING		SPACER COUPLING	
												DNA	DNM	L	WEIGHT kg	L	WEIGHT kg
KDNE 40-160/161/A/BAQE/1/1,1/4 M MCE11/C	80	60	160	65	197	800	540	360	320	19	262	65	40	989	95	1089	100
KDNE 40-160/161/A/BAQE/1/1,1/4 T MCE30/C	80	60	160	65	197	800	540	360	320	19	353	65	40	1056	97,6	1156	102,6
KDNE 40-160/177/A/BAQE/1/1,5/4 M MCE15/C	80	60	160	65	197	900	600	390	350	19	262	65	40	989	105	1089	110
KDNE 40-160/177/A/BAQE/1/1,5/4 T MCE30/C	80	60	160	65	197	900	600	390	350	19	353	65	40	1056	107,6	1156	112,6

KDNE 40-200 - 4 POLES - STANDARDISED CENTRIFUGAL ELECTRIC PUMPS WITH INVERTER FOR CIRCULATION SYSTEMS



Pumped liquid temperature range: from -10 °C to +140 °C (MCE/C) - Maximum ambient temperature: +40 °C

= 1450 1/min

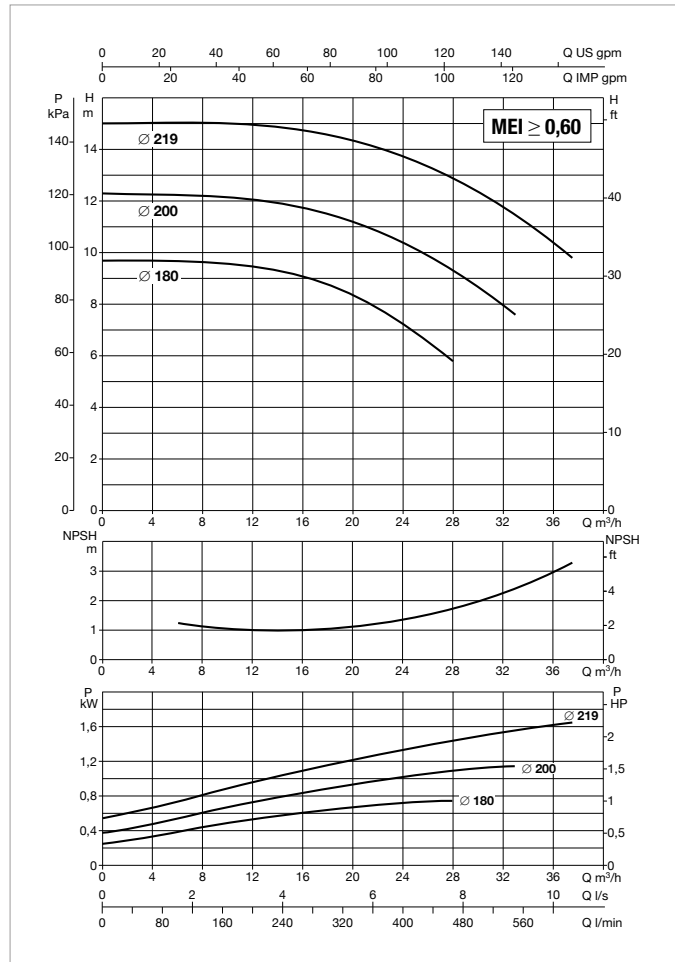
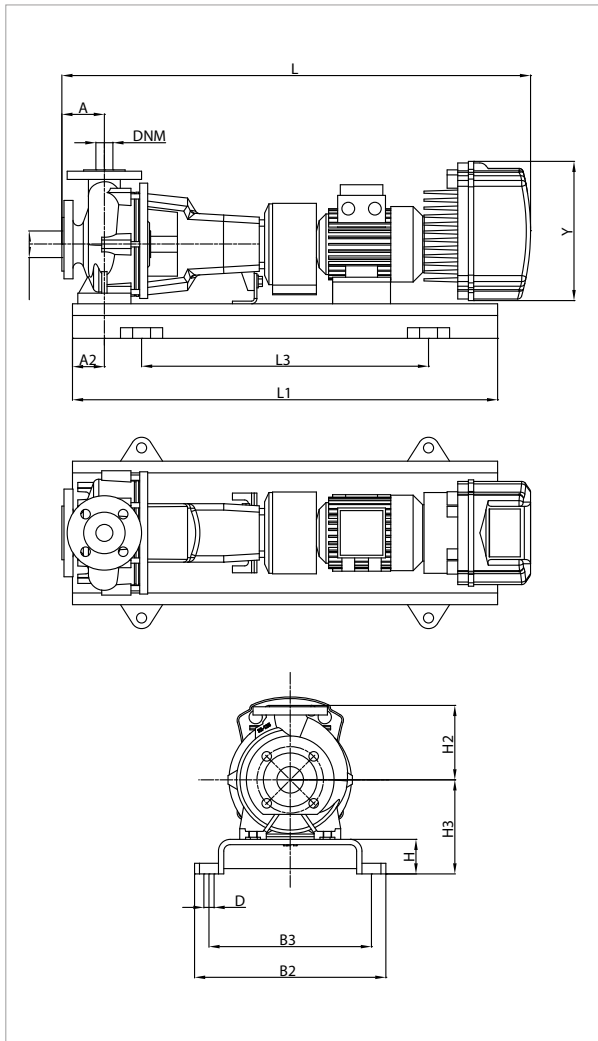

See hydraulic efficiency details on page 241.

The performance curves are based on kinematic viscosity values = 1 mm²/s and density equal to 1000 kg/m³. Curve tolerance according to ISO 9906.

MODEL	MCE MODEL	POWER INPUT 50 Hz	P2 NOMINAL		In A
			kW	HP	
KDNE 40-200/180/A/BAQE/1/1,1/4 M MCE11/C	MCE11/C	1 x 230 ~V	1,1	1,5	10,9
KDNE 40-200/180/A/BAQE/1/1,1/4 T MCE30/C	MCE30/C	3 x 400 ~V	1,1	1,5	3,4
KDNE 40-200/200/A/BAQE/1/1,5/4 M MCE15/C	MCE15/C	1 x 230 ~V	1,5	2	14,1
KDNE 40-200/200/A/BAQE/1/1,5/4 T MCE30/C	MCE30/C	3 x 400 ~V	1,5	2	4,5
KDNE 40-200/219/A/BAQE/1/2,2/4 M MCE22/C	MCE22/C	1 x 230 ~V	2,2	3	19,7
KDNE 40-200/219/A/BAQE/1/2,2/4 T MCE30/C	MCE30/C	3 x 400 ~V	2,2	3	6,4

MODEL	A	A2	H2	H	H3	L1	L3	B2	B3	D	Y	FLANGE DIMENSIONS (mm)		STANDARD COUPLING		SPACER COUPLING	
												DNA	DNM	L	WEIGHT kg	L	WEIGHT kg
KDNE 40-200/180/A/BAQE/1/1,1/4 M MCE11/C	100	60	180	65	225	900	600	390	350	19	262	65	40	1009	105	1109	110
KDNE 40-200/180/A/BAQE/1/1,1/4 T MCE30/C	100	60	180	65	225	900	600	390	350	19	353	65	40	1076	107,6	1176	112,6
KDNE 40-200/200/A/BAQE/1/1,5/4 M MCE15/C	100	60	180	65	225	900	600	390	350	19	262	65	40	1009	109	1109	114
KDNE 40-200/200/A/BAQE/1/1,5/4 T MCE30/C	100	60	180	65	225	900	600	390	350	19	353	65	40	1076	111,6	1176	116,6
KDNE 40-200/219/A/BAQE/1/2,2/4 M MCE22/C	100	60	180	65	225	900	600	390	350	19	262	65	40	1046	115	1146	120
KDNE 40-200/219/A/BAQE/1/2,2/4 T MCE30/C	100	60	180	65	225	900	600	390	350	19	353	65	40	1113	117,6	1213	122,6



KDNE 40-250 - 4 POLES - STANDARDISED CENTRIFUGAL ELECTRIC PUMPS WITH INVERTER FOR CIRCULATION SYSTEMS



Pumped liquid temperature range: from -10 °C to +140 °C (MCE/C) - Maximum ambient temperature: +40 °C

= 1450 1/min

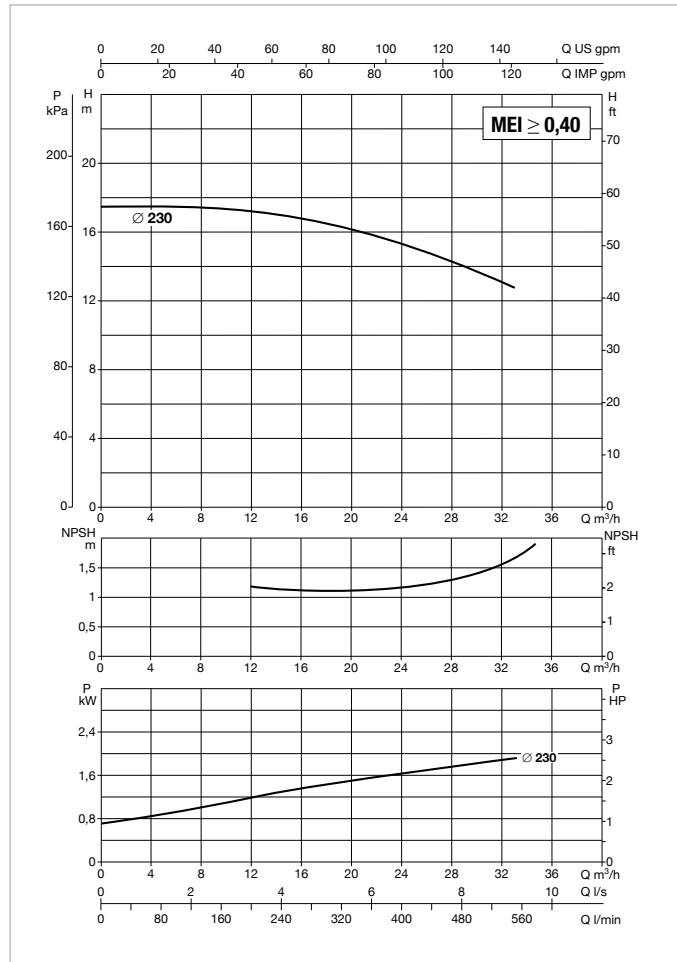
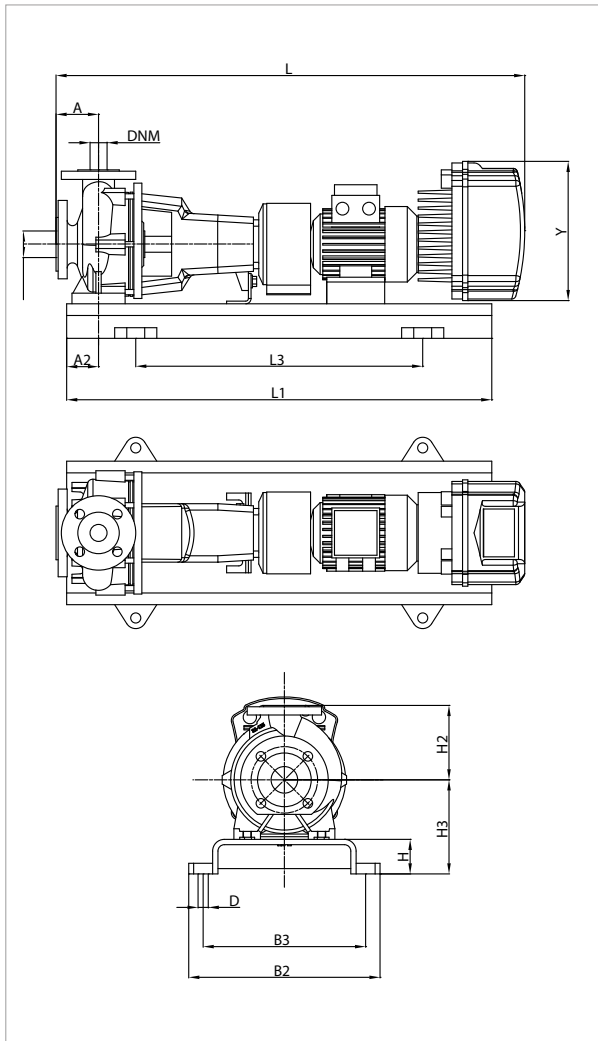

See hydraulic efficiency details on page 241.

The performance curves are based on kinematic viscosity values = 1 mm²/s and density equal to 1000 kg/m³. Curve tolerance according to ISO 9906.

MODEL	MCE MODEL	POWER INPUT 50 Hz	P2 NOMINAL		In A
			kW	HP	
KDNE 40-250/230/A/BAQE/1/2,2/4 M MCE22/C	MCE22/C	1 x 230 ~V	2,2	3	19,7
KDNE 40-250/230/A/BAQE/1/2,2/4 T MCE30/C	MCE30/C	3 x 400 ~V	2,2	3	6,4

MODEL	A	A2	H2	H	H3	L1	L3	B2	B3	D	Y	FLANGE DIMENSIONS (mm)		STANDARD COUPLING		SPACER COUPLING	
												DNA	DNM	L	WEIGHT kg	L	WEIGHT kg
												KDNE 40-250/230/A/BAQE/1/2,2/4 M MCE22/C	100	75	225	80	260
KDNE 40-250/230/A/BAQE/1/2,2/4 T MCE30/C	100	75	225	80	260	1000	660	450	400	24	353	65	40	1113	135,6	1213	140,6

KDNE 40-250 - 4 POLES - STANDARDISED CENTRIFUGAL ELECTRIC PUMPS WITH INVERTER FOR CIRCULATION OR PRESSURISATION SYSTEMS



Pumped liquid temperature range: from -10 °C to +140 °C (MCE/C) - from -10 °C to +80 °C (MCE/P) - Maximum ambient temperature: +40 °C = 1450 1/min

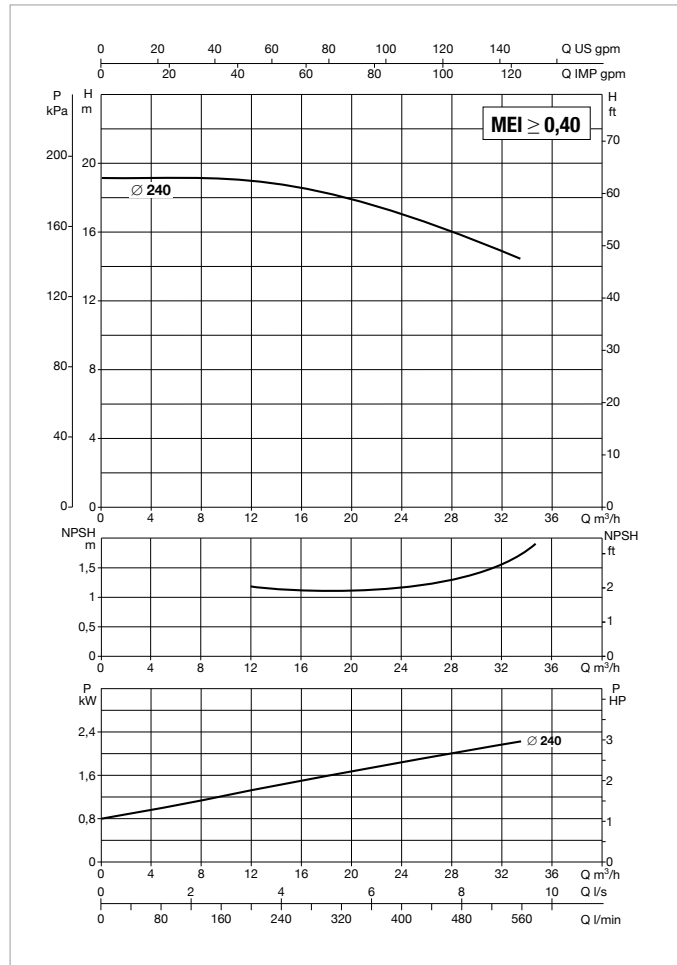
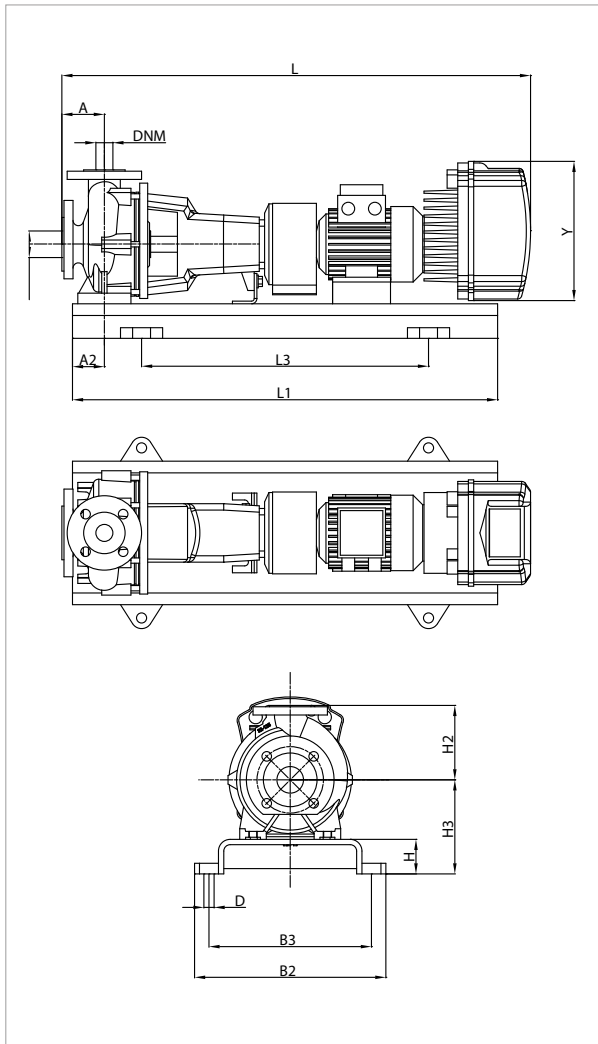

See hydraulic efficiency details on page 241.

The performance curves are based on kinematic viscosity values = 1 mm²/s and density equal to 1000 kg/m³. Curve tolerance according to ISO 9906.

MODEL	MCE MODEL	POWER INPUT 50 Hz	P2 NOMINAL		In A
			kW	HP	
KDNE 40-250/240/A/BAQE/1/3/4 T MCE30/C-P	MCE30/C - MCE30/P	3 x 400 ~V	3	4	7,9

MODEL	A	A2	H2	H	H3	L1	L3	B2	B3	D	Y	FLANGE DIMENSIONS (mm)		STANDARD COUPLING		SPACER COUPLING	
												DNA	DNM	L	WEIGHT kg	L	WEIGHT kg
												KDNE 40-250/240/A/BAQE/1/3/4 T MCE30/C-P	100	75	225	80	260

KDNE 40-250 - 4 POLES - STANDARDISED CENTRIFUGAL ELECTRIC PUMPS WITH INVERTER FOR PRESSURISATION SYSTEMS



Pumped liquid temperature range: from -10 °C to +80 °C (MCE/P) - Maximum ambient temperature: +40 °C

= 1450 1/min

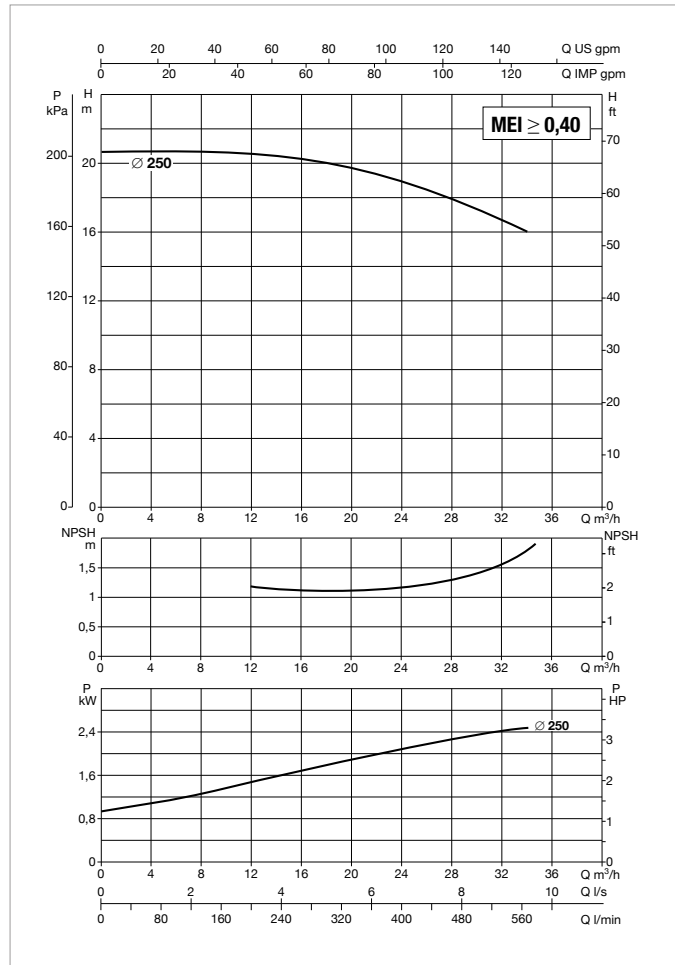
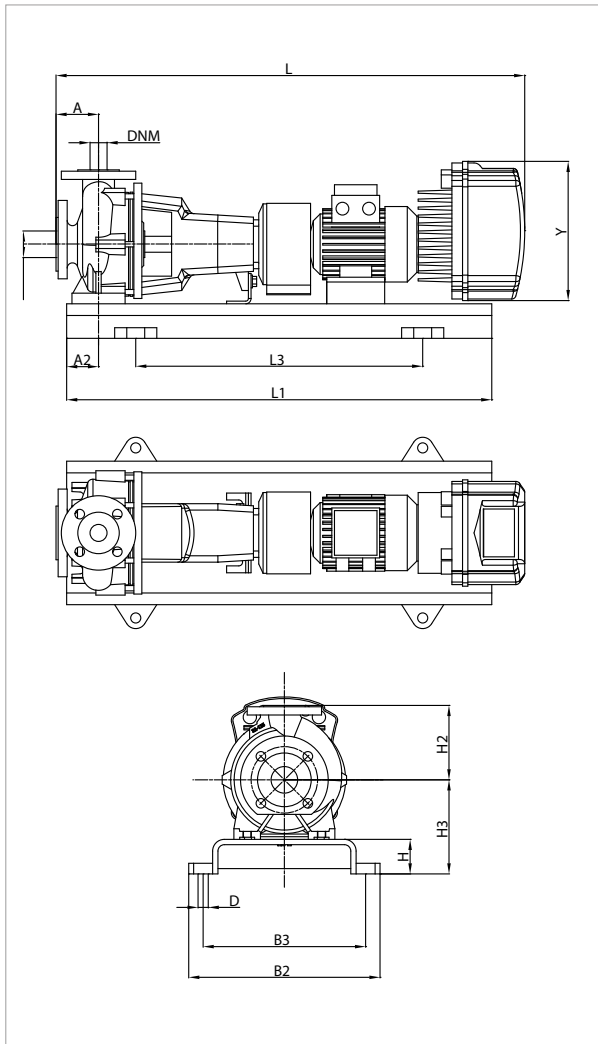

See hydraulic efficiency details on page 241.

The performance curves are based on kinematic viscosity values = 1 mm²/s and density equal to 1000 kg/m³. Curve tolerance according to ISO 9906.

MODEL	MCE MODEL	POWER INPUT 50 Hz	P2 NOMINAL		In A
			kW	HP	
KDNE 40-250/250/A/BAQE/1/4/4 MCE55/P	MCE30/P	3 x 400 ~V	3	4	8,8

MODEL	A	A2	H2	H	H3	L1	L3	B2	B3	D	Y	FLANGE DIMENSIONS (mm)		STANDARD COUPLING		SPACER COUPLING	
												DNA	DNM	L	WEIGHT kg	L	WEIGHT kg
												KDNE 40-250/250/A/BAQE/1/4/4 MCE55/P	100	75	225	80	260

KDNE 40-250 - 4 POLES - STANDARDISED CENTRIFUGAL ELECTRIC PUMPS WITH INVERTER FOR CIRCULATION SYSTEMS



Pumped liquid temperature range: from -10 °C to +140 °C (MCE/C) - Maximum ambient temperature: +40 °C

= 1450 1/min

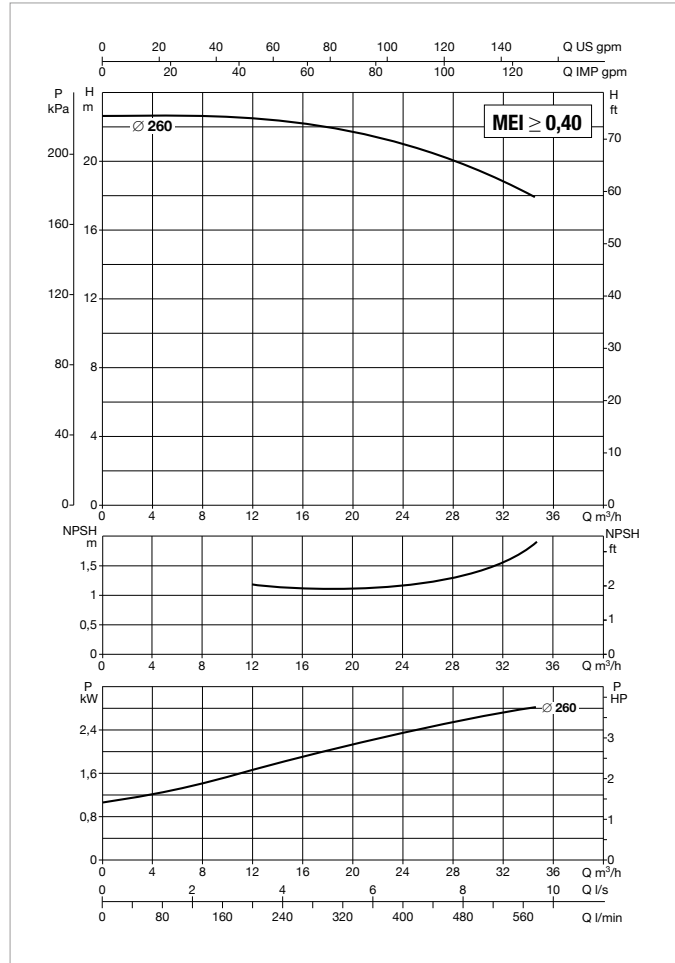
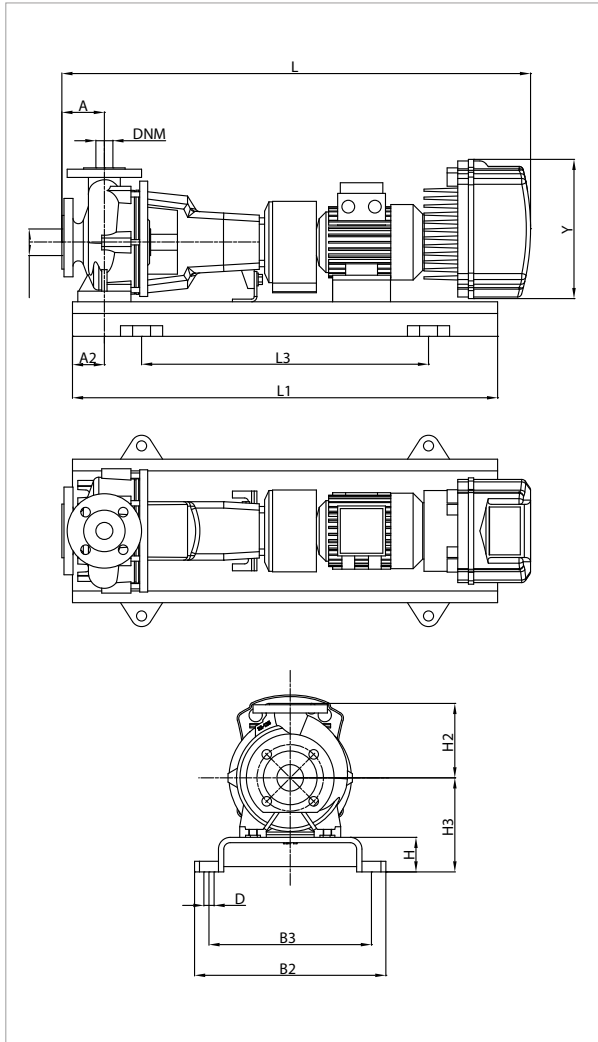

See hydraulic efficiency details on page 241.

The performance curves are based on kinematic viscosity values = 1 mm²/s and density equal to 1000 kg/m³. Curve tolerance according to ISO 9906.

MODEL	MCE MODEL	POWER INPUT 50 Hz	P2 NOMINAL		In A
			kW	HP	
KDNE 40-250/260/A/BAQE/1/4/4 T MCE55/C	MCE55/C	3 x 400 ~V	4	5,5	10,0

MODEL	A	A2	H2	H	H3	L1	L3	B2	B3	D	Y	FLANGE DIMENSIONS (mm)		STANDARD COUPLING		SPACER COUPLING	
												DNA	DNM	L	WEIGHT kg	L	WEIGHT kg
												KDNE 40-250/260/A/BAQE/1/4/4 T MCE55/C	100	75	225	80	260

KDNE 50-125 - 4 POLES - STANDARDISED CENTRIFUGAL ELECTRIC PUMPS WITH INVERTER FOR CIRCULATION SYSTEMS



Pumped liquid temperature range: from -10 °C to +140 °C (MCE/C) - Maximum ambient temperature: +40 °C

= 1450 1/min

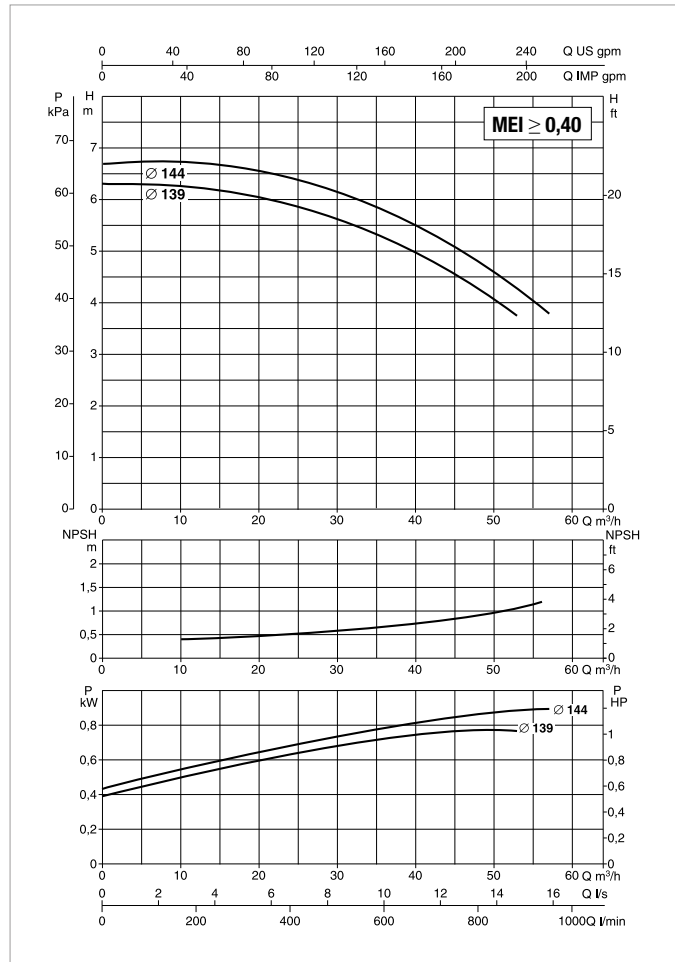
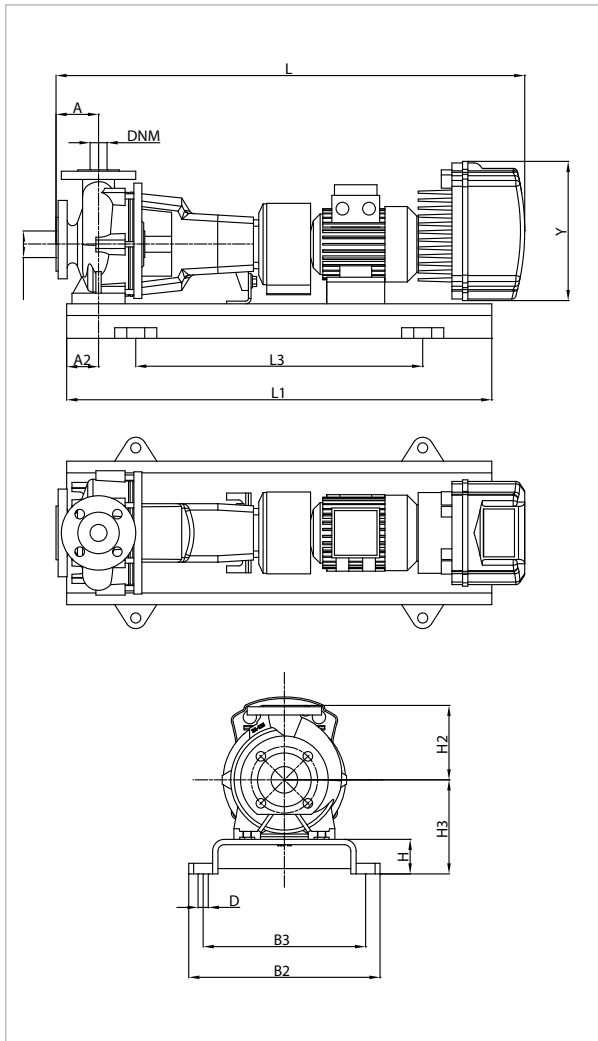

See hydraulic efficiency details on page 241.

The performance curves are based on kinematic viscosity values = 1 mm²/s and density equal to 1000 kg/m³. Curve tolerance according to ISO 9906.

MODEL	MCE MODEL	POWER INPUT 50 Hz	P2 NOMINAL		In A
			kW	HP	
KDNE 50-125/139/A/BAQE/1/1,1/4 M MCE11/C	MCE11/C	1 x 230 ~V	1,1	1,5	10,9
KDNE 50-125/139/A/BAQE/1/1,1/4 T MCE30/C	MCE30/C	3 x 400 ~V	1,1	1,5	3,4
KDNE 50-125/144/A/BAQE/1/1,5/4 M MCE15/C	MCE15/C	1 x 230 ~V	1,5	2	14,1
KDNE 50-125/144/A/BAQE/1/1,5/4 T MCE30/C	MCE30/C	3 x 400 ~V	1,5	2	4,5

MODEL	A	A2	H2	H	H3	L1	L3	B2	B3	D	Y	FLANGE DIMENSIONS (mm)		STANDARD COUPLING		SPACER COUPLING	
												DNA	DNM	L	WEIGHT kg	L	WEIGHT kg
												KDNE 50-125/139/A/BAQE/1/1,1/4 M MCE11/C	100	60	160	65	197
KDNE 50-125/139/A/BAQE/1/1,1/4 T MCE30/C	100	60	160	65	197	800	540	360	320	19	353	65	50	1076	99,6	1176	104,6
KDNE 50-125/144/A/BAQE/1/1,5/4 M MCE15/C	100	60	160	65	197	900	600	390	350	19	262	65	50	1009	105	1109	110
KDNE 50-125/144/A/BAQE/1/1,5/4 T MCE30/C	100	60	160	65	197	900	600	390	350	19	353	65	50	1076	107,6	1176	112,6

KDNE 50-160 - 4 POLES - STANDARDISED CENTRIFUGAL ELECTRIC PUMPS WITH INVERTER FOR CIRCULATION SYSTEMS



Pumped liquid temperature range: from -10 °C to +140 °C (MCE/C) - Maximum ambient temperature: +40 °C

= 1450 1/min

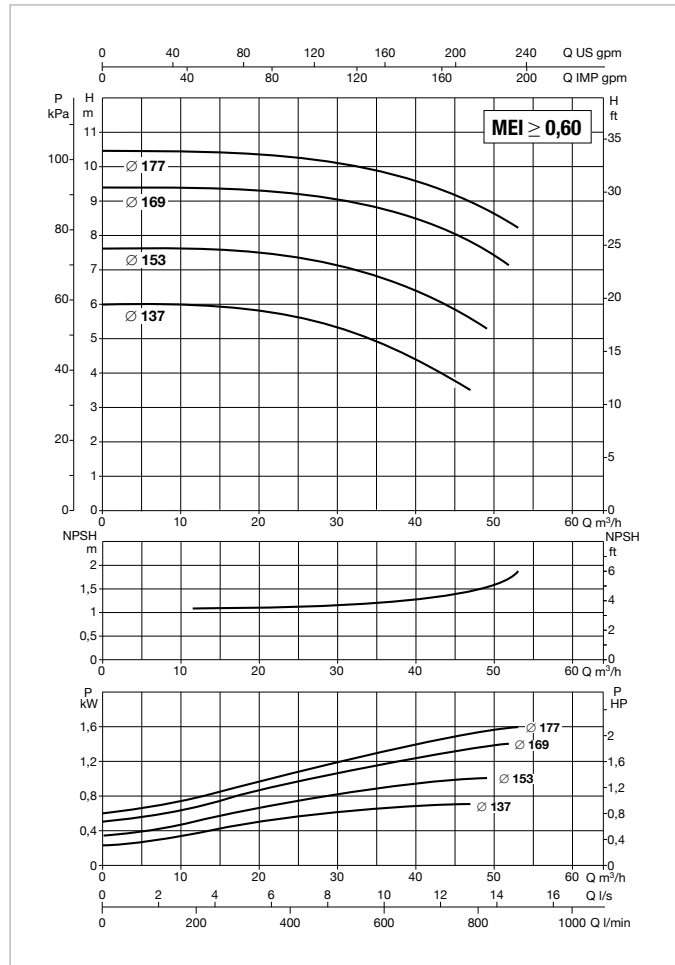
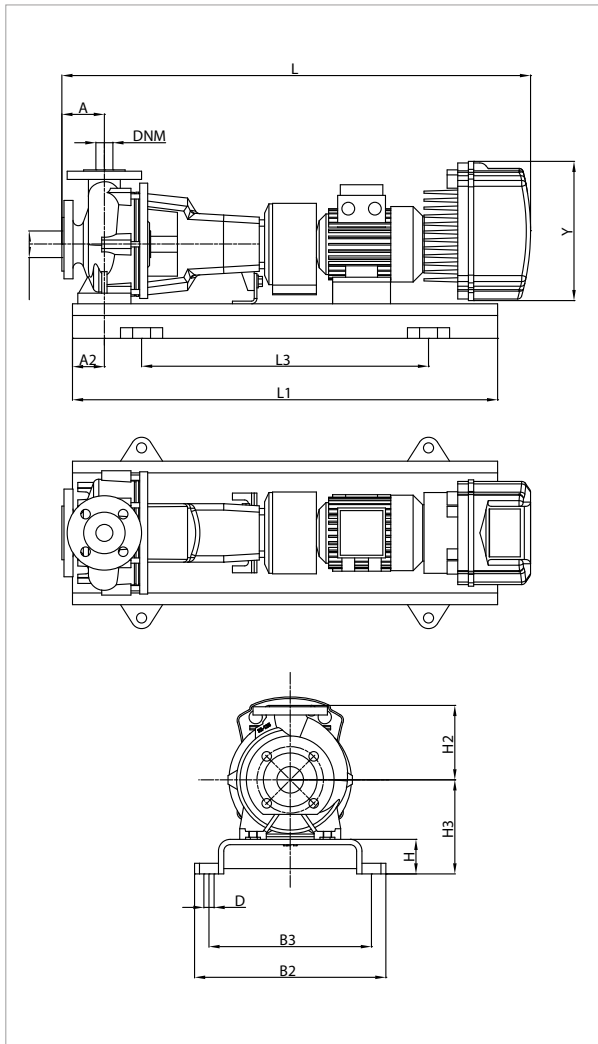

See hydraulic efficiency details on page 241.

The performance curves are based on kinematic viscosity values = 1 mm²/s and density equal to 1000 kg/m³. Curve tolerance according to ISO 9906.

MODEL	MCE MODEL	POWER INPUT 50 Hz	P2 NOMINAL		In A
			kW	HP	
KDNE 50-160/137/A/BAQE/1/1,1/4 M MCE11/C	MCE11/C	1 x 230 ~V	1,1	1,5	10,9
KDNE 50-160/137/A/BAQE/1/1,1/4 T MCE30/C	MCE30/C	3 x 400 ~V	1,1	1,5	3,4
KDNE 50-160/153/A/BAQE/1/1,5/4 M MCE15/C	MCE15/C	1 x 230 ~V	1,5	2	14,1
KDNE 50-160/153/A/BAQE/1/1,5/4 T MCE30/C	MCE30/C	3 x 400 ~V	1,5	2	4,5
KDNE 50-160/169/A/BAQE/1/2,2/4 M MCE22/C	MCE22/C	1 x 230 ~V	2,2	3	19,7
KDNE 50-160/169/A/BAQE/1/2,2/4 T MCE30/C	MCE30/C	3 x 400 ~V	2,2	3	6,4
KDNE 50-160/177/A/BAQE/1/3/4 T MCE30/C	MCE30/C	3 x 400 ~V	3	4	7,9

MODEL	A	A2	H2	H	H3	L1	L3	B2	B3	D	Y	FLANGE DIMENSIONS (mm)		STANDARD COUPLING		SPACER COUPLING	
												DNA	DNM	L	WEIGHT kg	L	WEIGHT kg
												KDNE 50-160/137/A/BAQE/1/1,1/4 M MCE11/C	100	60	180	65	225
KDNE 50-160/137/A/BAQE/1/1,1/4 T MCE30/C	100	60	180	65	225	900	600	390	350	19	353	65	50	1076	16,6	1176	11,6
KDNE 50-160/153/A/BAQE/1/1,5/4 M MCE15/C	100	60	180	65	225	900	600	390	350	19	262	65	50	1009	107	1109	112
KDNE 50-160/153/A/BAQE/1/1,5/4 T MCE30/C	100	60	180	65	225	900	600	390	350	19	353	65	50	1076	109,6	1176	114,6
KDNE 50-160/169/A/BAQE/1/2,2/4 M MCE22/C	100	60	180	65	225	900	600	390	350	19	262	65	50	1046	111	1146	116
KDNE 50-160/169/A/BAQE/1/2,2/4 T MCE30/C	100	60	180	65	225	900	600	390	350	19	353	65	50	1113	113,6	1213	118,6
KDNE 50-160/177/A/BAQE/1/3/4 T MCE30/C	100	60	180	65	225	900	600	390	350	19	353	65	50	1046	119	1146	124

KDNE 50-200 - 4 POLES - STANDARDISED CENTRIFUGAL ELECTRIC PUMPS WITH INVERTER FOR CIRCULATION SYSTEMS



Pumped liquid temperature range: from -10 °C to +140 °C (MCE/C) - Maximum ambient temperature: +40 °C

= 1450 1/min

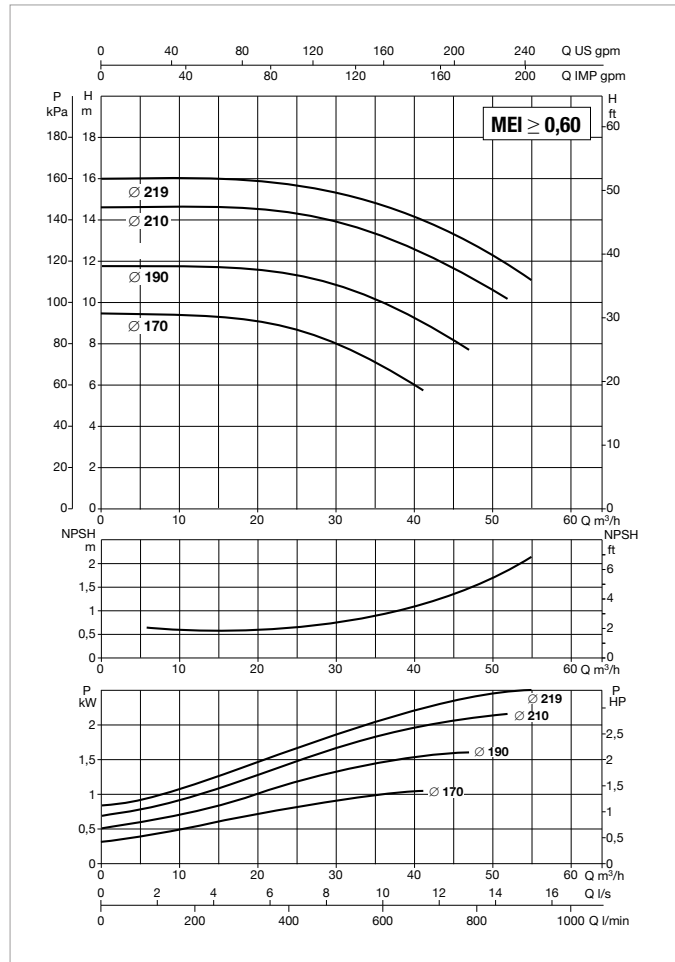
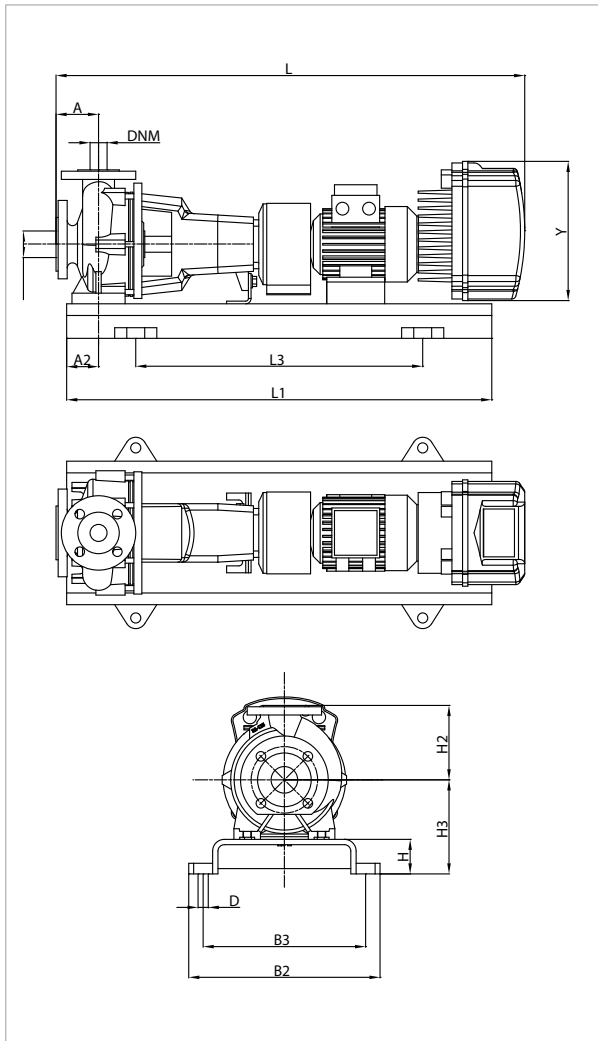

See hydraulic efficiency details on page 241.

The performance curves are based on kinematic viscosity values = 1 mm²/s and density equal to 1000 kg/m³. Curve tolerance according to ISO 9906.

MODEL	MCE MODEL	POWER INPUT 50 Hz	P2 NOMINAL		In A
			kW	HP	
KDNE 50-200/170/A/BAQE/1/1,5/4 M MCE15/C	MCE15/C	1 x 230 ~V	1,5	2	14,1
KDNE 50-200/170/A/BAQE/1/1,5/4 T MCE30/C	MCE30/C	3 x 400 ~V	1,5	2	4,5
KDNE 50-200/190/A/BAQE/1/2,2/4 M MCE22/C	MCE22/C	1 x 230 ~V	2,2	3	19,7
KDNE 50-200/190/A/BAQE/1/2,2/4 T MCE30/C	MCE30/C	3 x 400 ~V	2,2	3	6,4
KDNE 50-200/210/A/BAQE/1/3/4 T MCE30/C	MCE30/C	3 x 400 ~V	3	4	7,9
KDNE 50-200/219/A/BAQE/1/4/4 T MCE55/C	MCE55/C	3 x 400 ~V	4	5,5	10,0

MODEL	A	A2	H2	H	H3	L1	L3	B2	B3	D	Y	FLANGE DIMENSIONS (mm)		STANDARD COUPLING	SPACER COUPLING		
												DNA	DNM	L	L	WEIGHT kg	WEIGHT kg
KDNE 50-200/170/A/BAQE/1/1,5/4 M MCE15/C	100	60	200	65	225	900	600	390	350	19	262	65	50	1009	118	1109	123
KDNE 50-200/170/A/BAQE/1/1,5/4 T MCE30/C	100	60	200	65	225	900	600	390	350	19	353	65	50	1076	120,6	1176	125,6
KDNE 50-200/190/A/BAQE/1/2,2/4 M MCE22/C	100	60	200	65	225	900	600	390	350	19	262	65	50	1046	127	1146	132
KDNE 50-200/190/A/BAQE/1/2,2/4 T MCE30/C	100	60	200	65	225	900	600	390	350	19	353	65	50	1113	129,6	1213	134,6
KDNE 50-200/210/A/BAQE/1/3/4 T MCE30/C	100	60	200	65	225	900	600	390	350	19	353	65	50	1046	131	1146	136
KDNE 50-200/219/A/BAQE/1/4/4 T MCE55/C	100	60	200	65	225	900	600	390	350	19	353	65	50	1069	131	1169	136

KDNE 50-250 - 4 POLES - STANDARDISED CENTRIFUGAL ELECTRIC PUMPS WITH INVERTER FOR CIRCULATION SYSTEMS



Pumped liquid temperature range: from -10 °C to +140 °C (MCE/C) - Maximum ambient temperature: +40 °C

= 1450 1/min

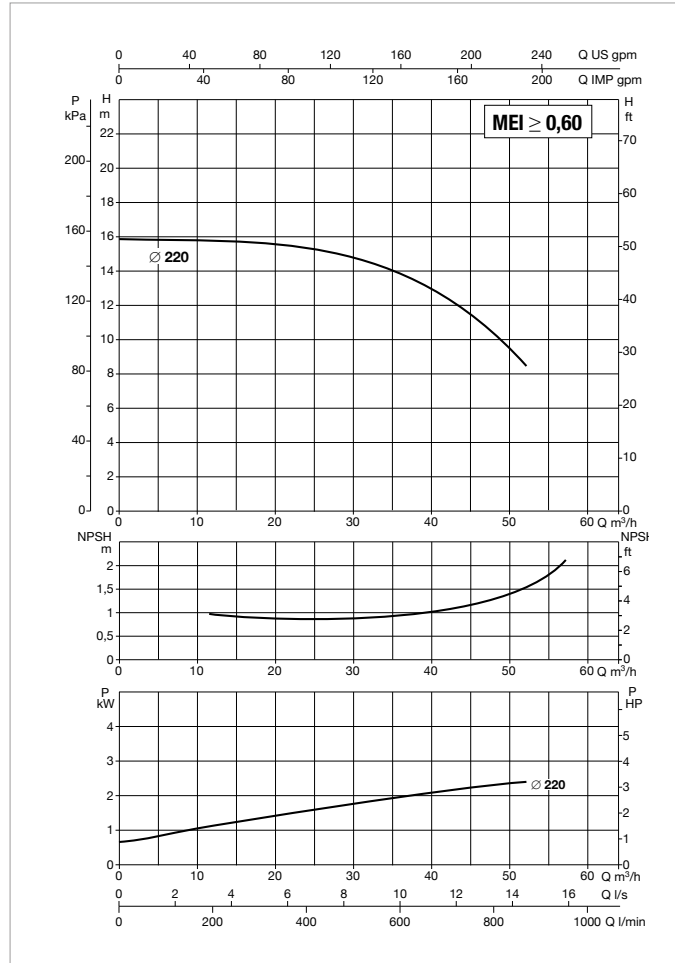
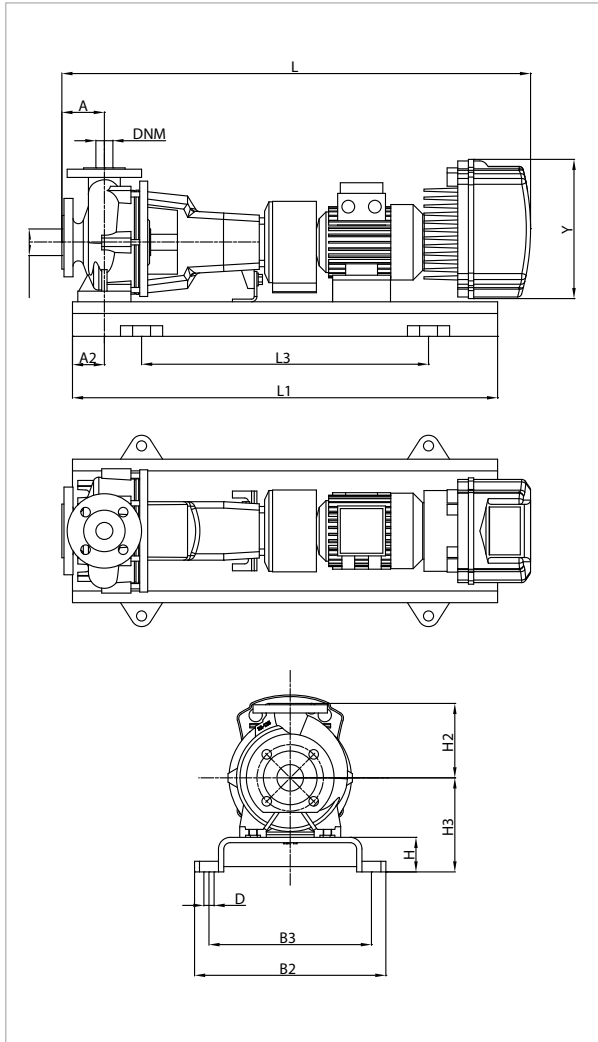

See hydraulic efficiency details on page 241.

The performance curves are based on kinematic viscosity values = 1 mm²/s and density equal to 1000 kg/m³. Curve tolerance according to ISO 9906.

MODEL	MCE MODEL	POWER INPUT 50 Hz	P2 NOMINAL		In A
			kW	HP	
KDNE 50-250/220/A/BAQE/1/3/4 T MCE30/C	MCE30/C	3 x 400 ~V	3	4	7,9

MODEL	A	A2	H2	H	H3	L1	L3	B2	B3	D	Y	FLANGE DIMENSIONS (mm)		STANDARD COUPLING		SPACER COUPLING	
												DNA	DNM	L	WEIGHT kg	L	WEIGHT kg
												KDNE 50-250/220/A/BAQE/1/3/4 T MCE30/C	100	75	225	80	260

KDNE 50-250 - 4 POLES - STANDARDISED CENTRIFUGAL ELECTRIC PUMPS WITH INVERTER FOR CIRCULATION OR PRESSURISATION SYSTEMS

MCE-C

MCE-P

Pumped liquid temperature range: from -10 °C to +140 °C (MCE/C) - from -10 °C to +80 °C (MCE/P) - Maximum ambient temperature: +40 °C = 1450 1/min

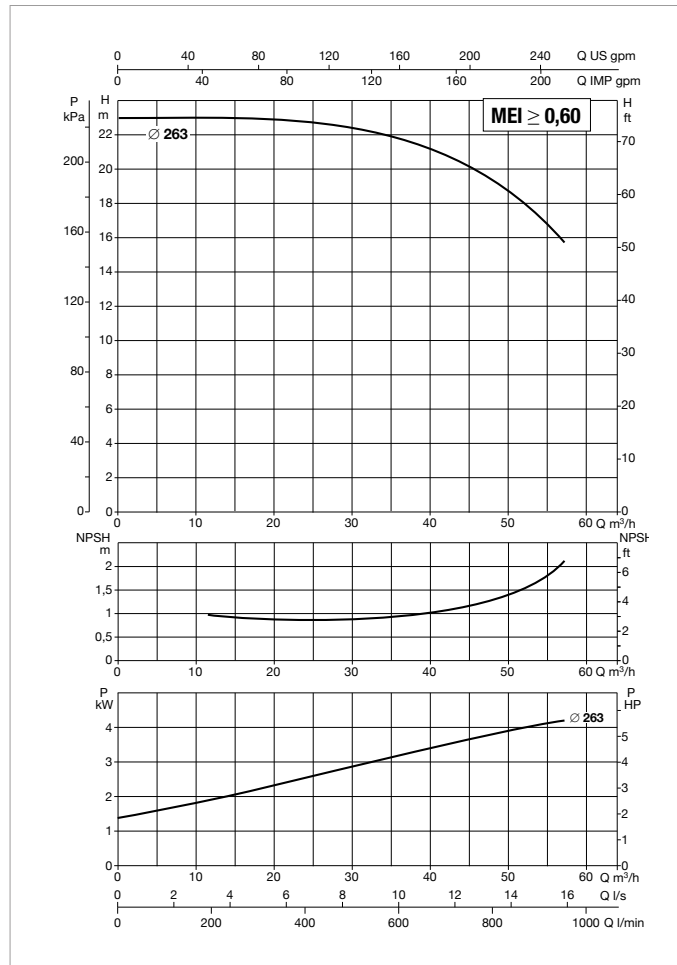
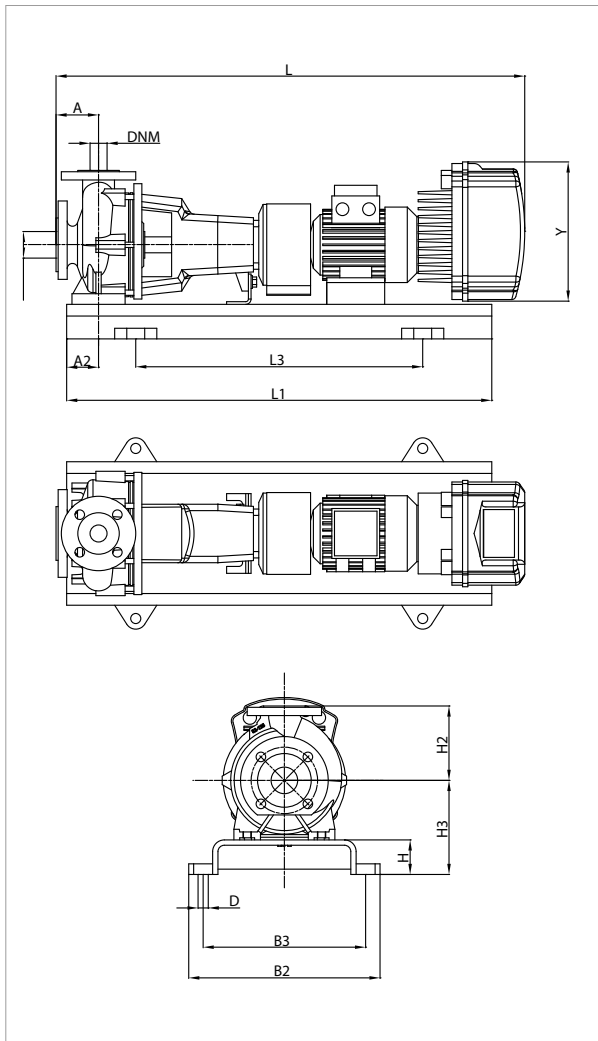

See hydraulic efficiency details on page 241.

The performance curves are based on kinematic viscosity values = 1 mm²/s and density equal to 1000 kg/m³. Curve tolerance according to ISO 9906.

MODEL	MCE MODEL	POWER INPUT 50 Hz	P2 NOMINAL		In A
			kW	HP	
KDNE 50-250/263/A/BAQE/1/5,5/4 T MCE55/C-P	MCE55/C - MCE55/P	3 x 400 ~V	5,5	7,5	13,4

MODEL	A	A2	H2	H	H3	L1	L3	B2	B3	D	Y	FLANGE DIMENSIONS (mm)		STANDARD COUPLING		SPACER COUPLING	
												DNA	DNM	L	WEIGHT kg	L	WEIGHT kg
												KDNE 50-250/263/A/BAQE/1/5,5/4 T MCE55/C-P	100	75	225	80	260

KDNE 65-125 - 4 POLES - STANDARDISED CENTRIFUGAL ELECTRIC PUMPS WITH INVERTER FOR CIRCULATION SYSTEMS



Pumped liquid temperature range: from -10 °C to +140 °C (MCE/C) - Maximum ambient temperature: +40 °C

= 1450 1/min

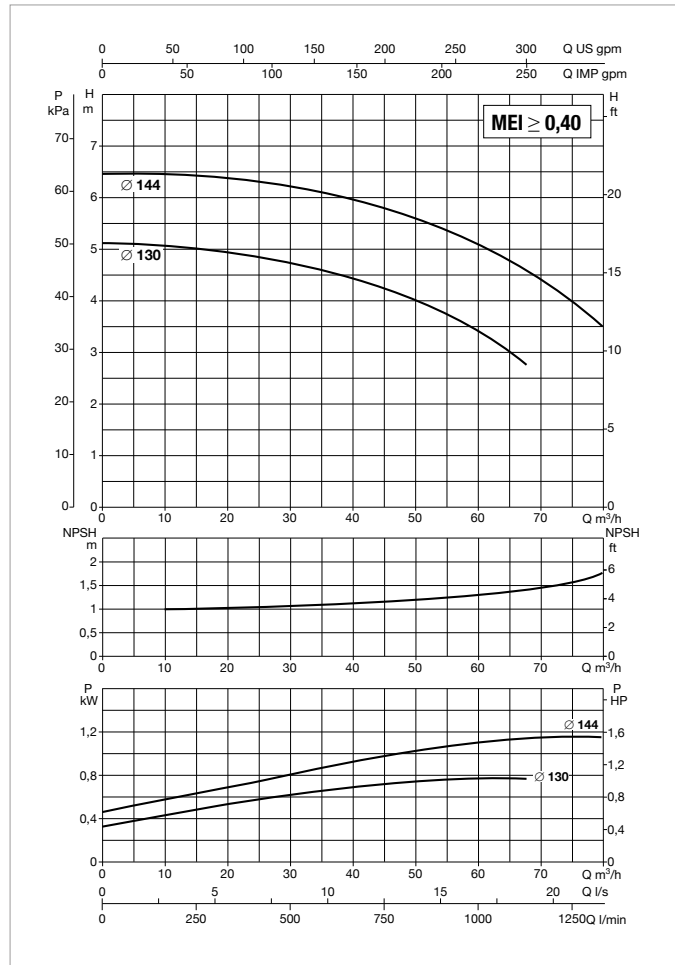
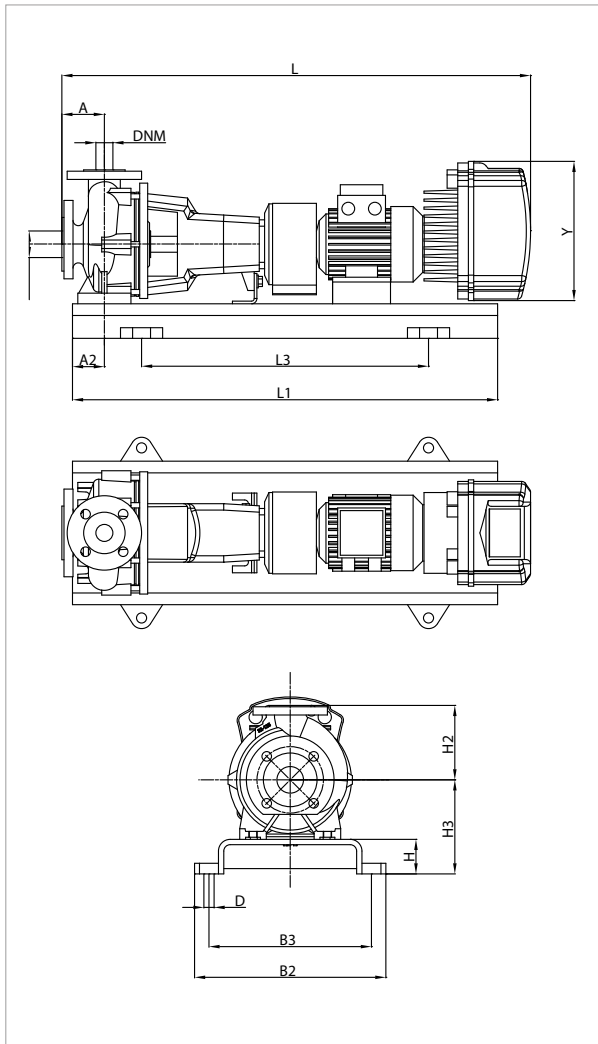

See hydraulic efficiency details on page 241.

The performance curves are based on kinematic viscosity values = 1 mm²/s and density equal to 1000 kg/m³. Curve tolerance according to ISO 9906.

MODEL	MCE MODEL	POWER INPUT 50 Hz	P2 NOMINAL		In A
			kW	HP	
KDNE 65-125/130/A/BAQE/1/1,1/4 M MCE11/C	MCE11/C	1 x 230 ~V	1,1	1,5	10,9
KDNE 65-125/130/A/BAQE/1/1,1/4 T MCE30/C	MCE30/C	3 x 400 ~V	1,1	1,5	3,4
KDNE 65-125/144/A/BAQE/1/1,5/4 M MCE15/C	MCE15/C	1 x 230 ~V	1,5	2	14,1
KDNE 65-125/144/A/BAQE/1/1,5/4 T MCE30/C	MCE30/C	3 x 400 ~V	1,5	2	4,5

MODEL	A	A2	H2	H	H3	L1	L3	B2	B3	D	Y	FLANGE DIMENSIONS (mm)		STANDARD COUPLING		SPACER COUPLING	
												DNA	DNM	L	WEIGHT kg	L	WEIGHT kg
												KDNE 65-125/130/A/BAQE/1/1,1/4 M MCE11/C	100	60	180	65	225
KDNE 65-125/130/A/BAQE/1/1,1/4 T MCE30/C	100	60	180	65	225	900	600	390	350	19	363	80	65	1076	106,6	1176	111,6
KDNE 65-125/144/A/BAQE/1/1,5/4 M MCE15/C	100	60	180	65	225	900	600	390	350	19	262	80	65	1009	107	1109	112
KDNE 65-125/144/A/BAQE/1/1,5/4 T MCE30/C	100	60	180	65	225	900	600	390	350	19	353	80	65	1076	109,6	1176	114,6

KDNE 65-160 - 4 POLES - STANDARDISED CENTRIFUGAL ELECTRIC PUMPS WITH INVERTER FOR CIRCULATION SYSTEMS



Pumped liquid temperature range: from -10 °C to +140 °C (MCE/C) - Maximum ambient temperature: +40 °C

= 1450 1/min

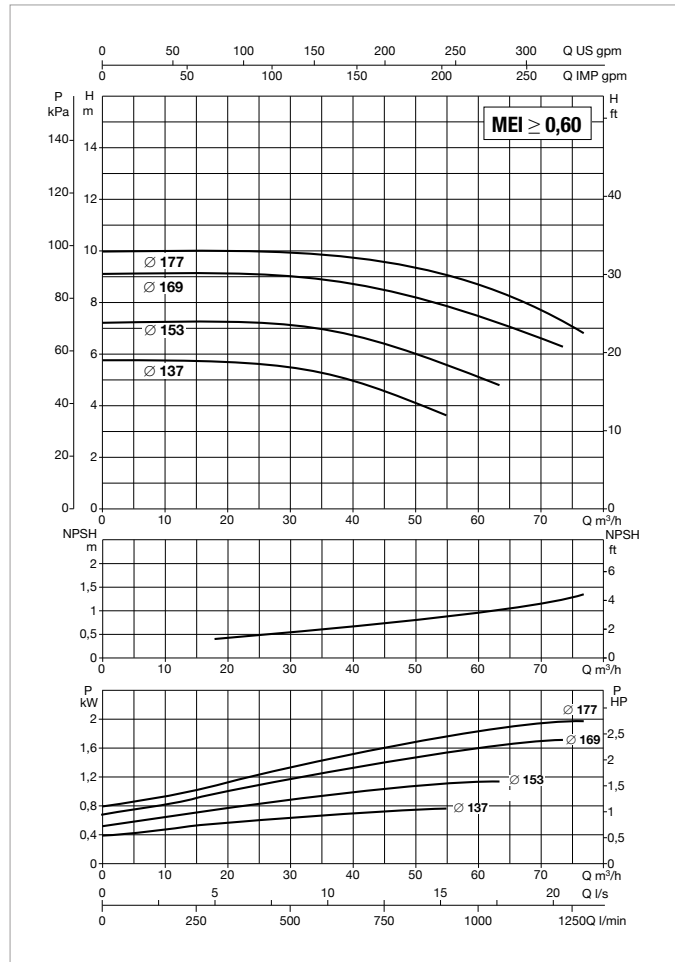
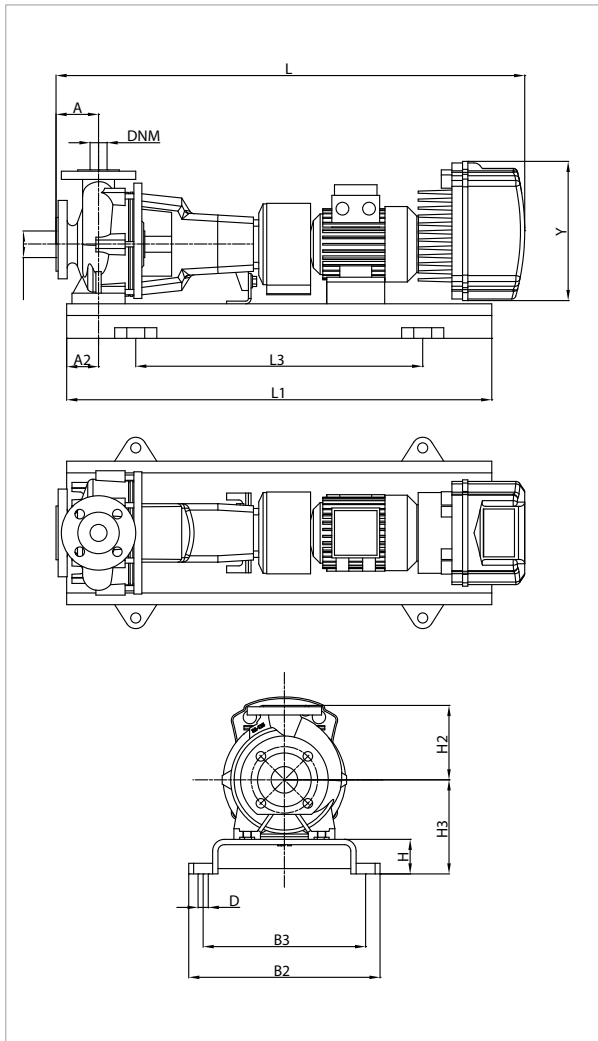

See hydraulic efficiency details on page 241.
The performance curves are based on kinematic viscosity values = 1 mm²/s and density equal to 1000 kg/m³. Curve tolerance according to ISO 9906.

MODEL	MCE MODEL	POWER INPUT 50 Hz	P2 NOMINAL		In A
			kW	HP	
KDNE 65-160/137/A/BAQE/1/1,1/4 M MCE11/C	MCE11/C	1 x 230 ~V	1,1	1,5	10,9
KDNE 65-160/137/A/BAQE/1/1,1/4 T MCE30/C	MCE30/C	3 x 400 ~V	1,1	1,5	3,4
KDNE 65-160/153/A/BAQE/1/1,5/4 M MCE15/C	MCE15/C	1 x 230 ~V	1,5	2	14,1
KDNE 65-160/153/A/BAQE/1/1,5/4 T MCE30/C	MCE30/C	3 x 400 ~V	1,5	2	4,5
KDNE 65-160/169/A/BAQE/1/2,2/4 M MCE22/C	MCE22/C	1 x 230 ~V	2,2	3	19,7
KDNE 65-160/169/A/BAQE/1/2,2/4 T MCE30/C	MCE30/C	3 x 400 ~V	2,2	3	6,4
KDNE 65-160/177/A/BAQE/1/3/4 T MCE30/C	MCE30/C	3 x 400 ~V	3	4	7,9

MODEL	A	A2	H2	H	H3	L1	L3	B2	B3	D	Y	FLANGE DIMENSIONS (mm)		STANDARD COUPLING		SPACER COUPLING	
												DNA	DNM	L	WEIGHT kg	L	WEIGHT kg
												KDNE 65-160/137/A/BAQE/1/1,1/4 M MCE11/C	100	60	200	65	225
KDNE 65-160/137/A/BAQE/1/1,1/4 T MCE30/C	100	60	200	65	225	900	600	390	350	19	353	80	65	1076	109,6	1176	114,6
KDNE 65-160/153/A/BAQE/1/1,5/4 M MCE15/C	100	60	200	65	225	900	600	390	350	19	262	80	65	1009	118	1109	123
KDNE 65-160/153/A/BAQE/1/1,5/4 T MCE30/C	100	60	200	65	225	900	600	390	350	19	353	80	65	1076	120,6	1176	125,6
KDNE 65-160/169/A/BAQE/1/2,2/4 M MCE22/C	100	60	200	65	225	900	600	390	350	19	262	80	65	1046	118	1146	123
KDNE 65-160/169/A/BAQE/1/2,2/4 T MCE30/C	100	60	200	65	225	900	600	390	350	19	353	80	65	1113	120,6	1213	125,6
KDNE 65-160/177/A/BAQE/1/3/4 T MCE30/C	100	60	200	65	225	900	600	390	350	19	353	80	65	1046	157	1146	162

KDNE 65-200 - 4 POLES - STANDARDISED CENTRIFUGAL ELECTRIC PUMPS WITH INVERTER FOR CIRCULATION SYSTEMS



Pumped liquid temperature range: from -10 °C to +140 °C (MCE/C) - Maximum ambient temperature: +40 °C

= 1450 1/min

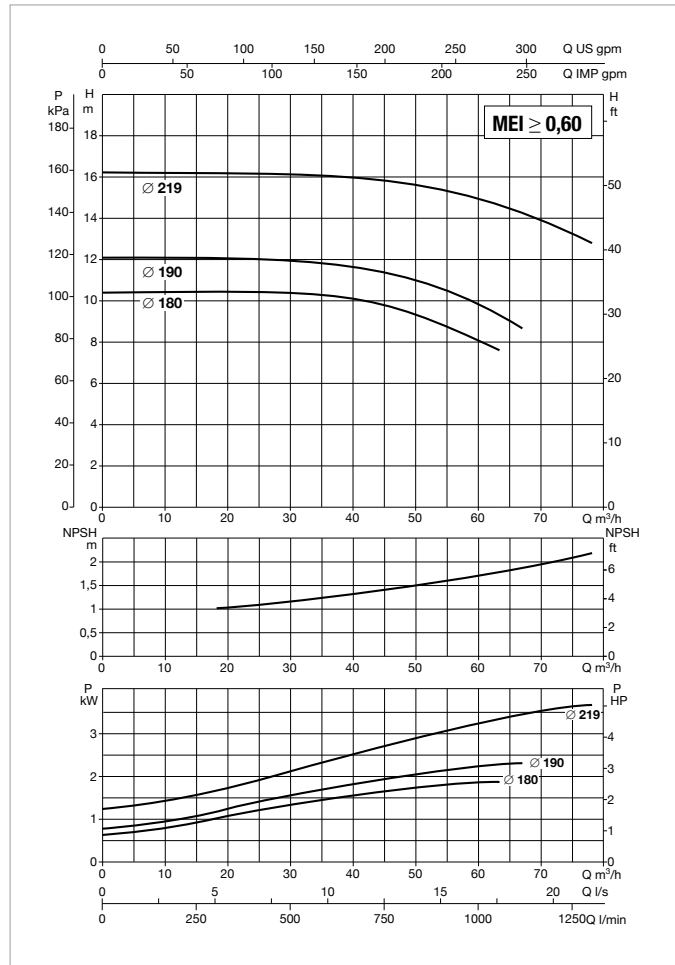
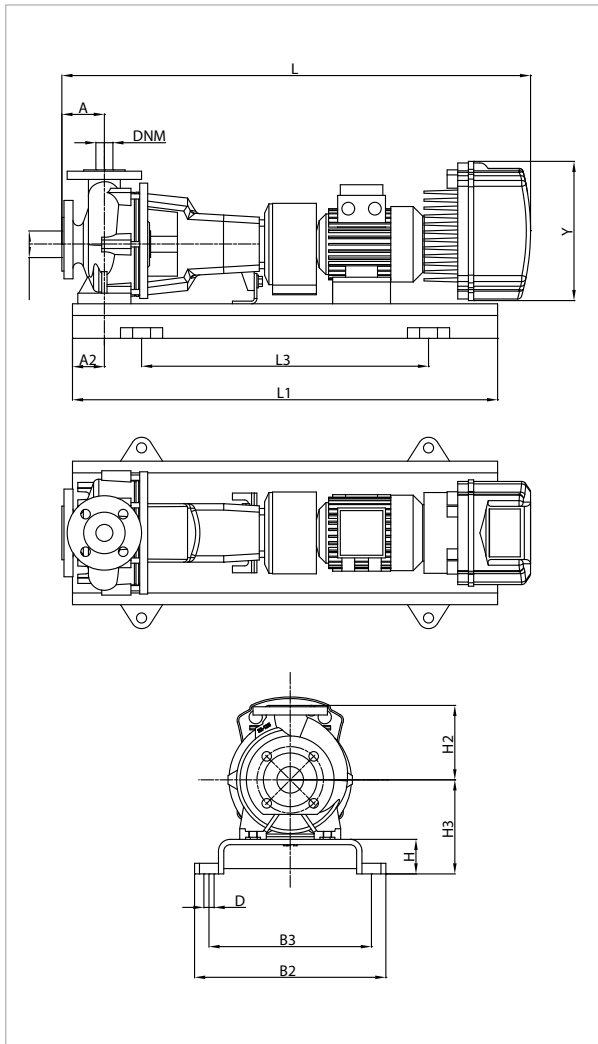

See hydraulic efficiency details on page 241.

The performance curves are based on kinematic viscosity values = 1 mm²/s and density equal to 1000 kg/m³. Curve tolerance according to ISO 9906.

MODEL	MCE MODEL	POWER INPUT 50 Hz	P2 NOMINAL		In A
			kW	HP	
KDNE 65-200/180/A/BAQE/1/2,2/4 M MCE22/C	MCE22/C	1 x 230 ~V	2,2	3	19,7
KDNE 65-200/180/A/BAQE/1/2,2/4 T MCE30/C	MCE30/C	3 x 400 ~V	2,2	3	6,4
KDNE 65-200/190/A/BAQE/1/3/4 T MCE30/C	MCE30/C	3 x 400 ~V	3	4	7,9
KDNE65-200/219/A/BAQE/1/5,5/4 T MCE55/C	MCE55/C	3 x 400 ~V	5,5	7,5	13,4

MODEL	A	A2	H2	H	H3	L1	L3	B2	B3	D	Y	FLANGE DIMENSIONS (mm)		STANDARD COUPLING		SPACER COUPLING	
												DNA	DNM	L	WEIGHT kg	L	WEIGHT kg
												KDNE 65-200/180/A/BAQE/1/2,2/4 M MCE22/C	100	75	225	80	260
KDNE 65-200/180/A/BAQE/1/2,2/4 T MCE30/C	100	75	225	80	260	1120	740	490	440	24	353	80	65	1113	153,6	1213	158,6
KDNE 65-200/190/A/BAQE/1/3/4 T MCE30/C	100	75	225	80	260	1120	740	490	440	24	353	80	65	1046	159	1146	164
KDNE65-200/219/A/BAQE/1/5,5/4 T MCE55/C	100	75	225	80	260	1120	740	490	440	24	353	80	65	1179	209	1279	214

KDNE 65-250 - 4 POLES - STANDARDISED CENTRIFUGAL ELECTRIC PUMPS WITH INVERTER FOR CIRCULATION OR PRESSURISATION SYSTEMS

MCE-C

MCE-P

Pumped liquid temperature range: from -10 °C to +140 °C (MCE/C) - from -10 °C to +80 °C (MCE/P) - Maximum ambient temperature: +40 °C
= 1450 1/min

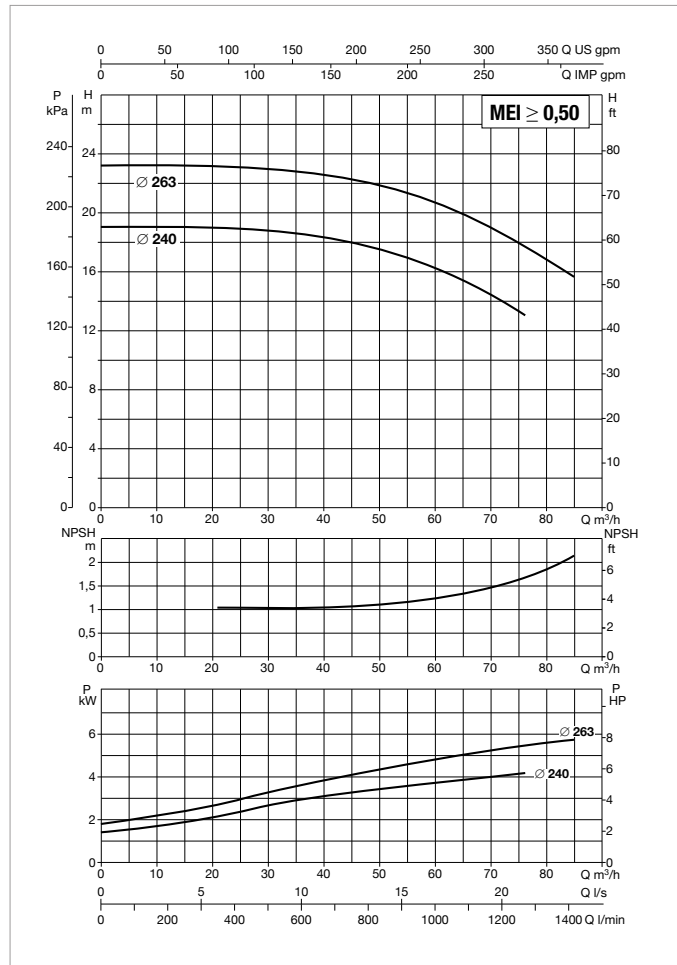
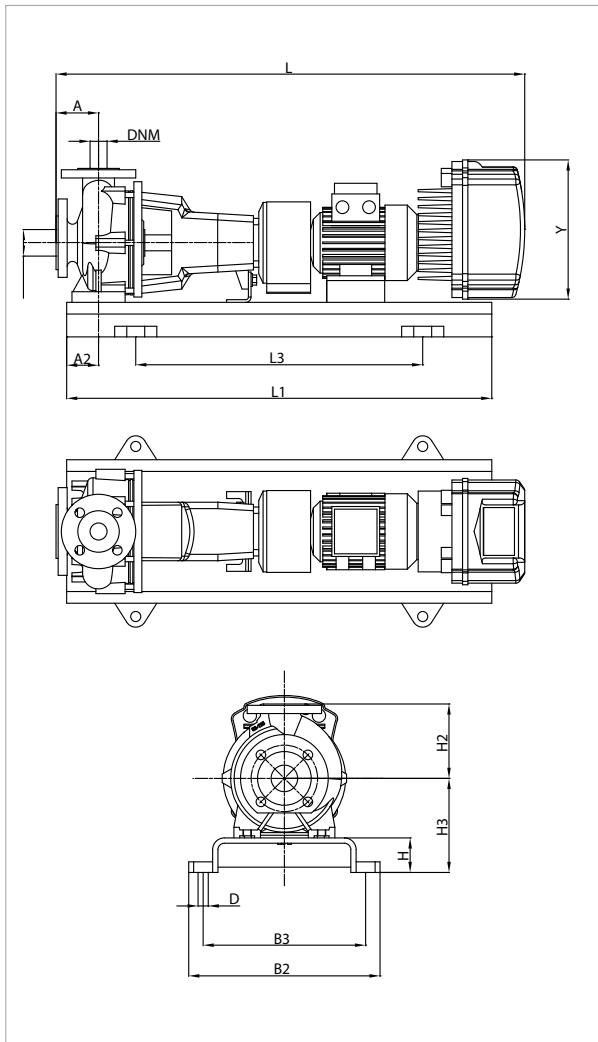

See hydraulic efficiency details on page 241.

The performance curves are based on kinematic viscosity values = 1 mm²/s and density equal to 1000 kg/m³. Curve tolerance according to ISO 9906.

MODEL	MCE MODEL	POWER INPUT 50 Hz	P2 NOMINAL		In A
			kW	HP	
KDNE 65-250/240/A/BAQE/1/5,5/4 T MCE55/C-P	MCE55/C - MCE55/P	3 x 400 ~V	5,5	7,5	13,4
KDNE 65-250/263/A/BAQE/1/7,5/4 T MCE110/C-P	MCE110/C - MCE110/P	3 x 400 ~V	7,5	10	17,9

MODEL	A	A2	H2	H	H3	L1	L3	B2	B3	D	Y	FLANGE DIMENSIONS (mm)		STANDARD COUPLING		SPACER COUPLING	
												DNA	DNM	L	WEIGHT kg	L	WEIGHT kg
												KDNE 65-250/240/A/BAQE/1/5,5/4 T MCE55/C-P	100	90	250	80	280
KDNE 65-250/263/A/BAQE/1/7,5/4 T MCE110/C-P	100	90	250	80	280	1120	740	490	440	24	426	80	65	1339	270	1479	275

KDNE 65-315 - 4 POLES - STANDARDISED CENTRIFUGAL ELECTRIC PUMPS WITH INVERTER FOR CIRCULATION OR PRESSURISATION SYSTEMS



Pumped liquid temperature range: from -10 °C to +140 °C (MCE/C) - from -10 °C to +80 °C (MCE/P) - Maximum ambient temperature: +40 °C = 1450 1/min

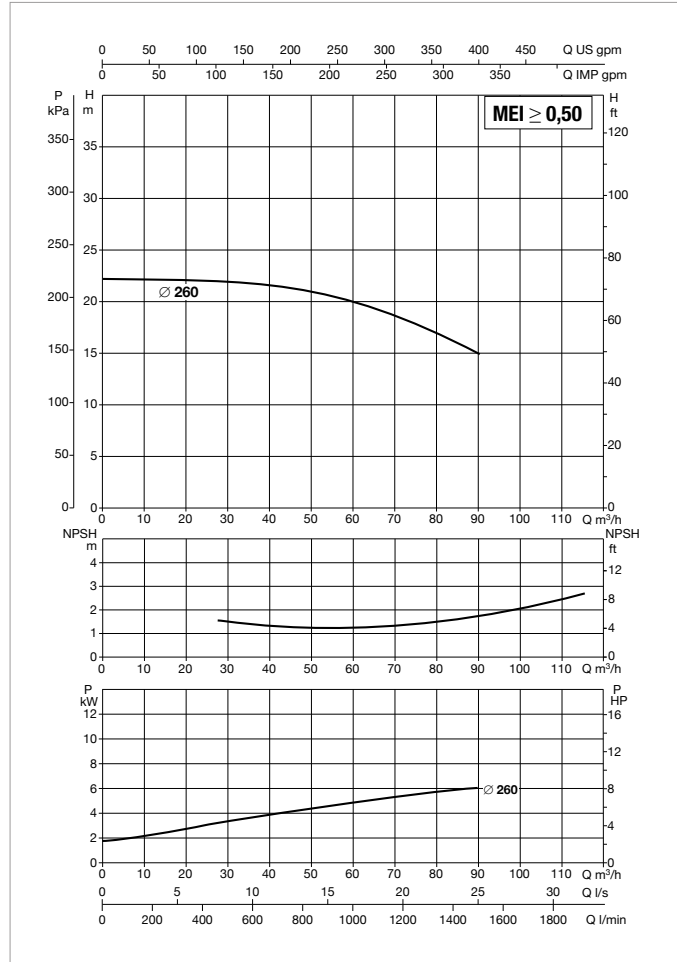
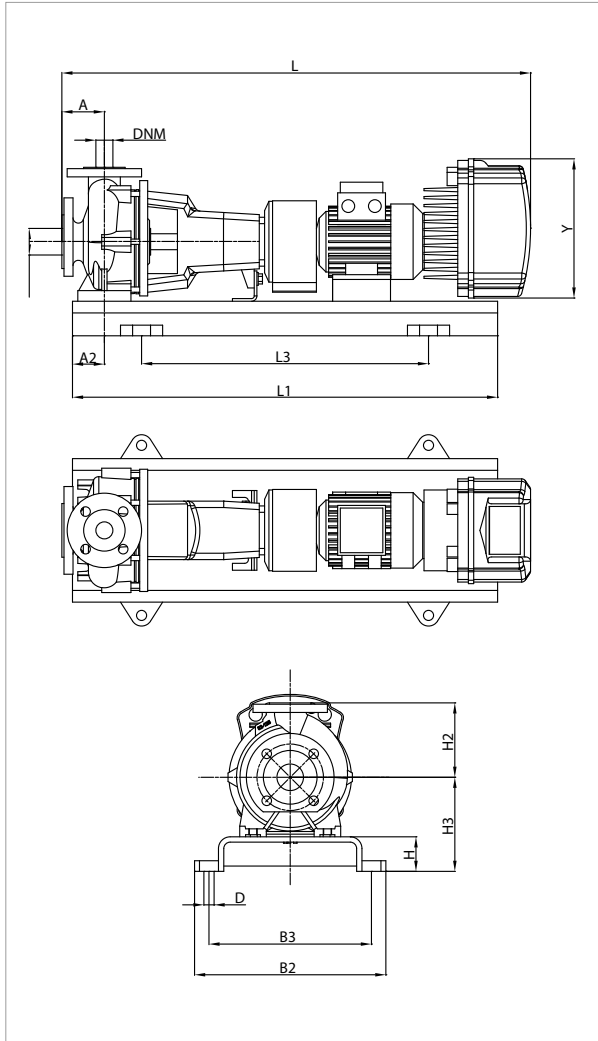

See hydraulic efficiency details on page 241.

The performance curves are based on kinematic viscosity values = 1 mm²/s and density equal to 1000 kg/m³. Curve tolerance according to ISO 9906.

MODEL	MCE MODEL	POWER INPUT 50 Hz	P2 NOMINAL		In A
			kW	HP	
KDNE 65-315/260/A/BAQE/1/7,5/4 T MCE110/C-P	MCE110/C - MCE110/P	3 x 400 ~V	7,5	10	17,9

MODEL	A	A2	H2	H	H3	L1	L3	B2	B3	D	Y	FLANGE DIMENSIONS (mm)		STANDARD COUPLING		SPACER COUPLING	
												DNA	DNM	L	WEIGHT kg	L	WEIGHT kg
KDNE 65-315/260/A/BAQE/1/7,5/4 T MCE110/C-P	125	90	280	80	305	1250	840	540	490	24	426	80	65	1364	305	1464	310

KDNE 65-315 - 4 POLES - STANDARDISED CENTRIFUGAL ELECTRIC PUMPS WITH INVERTER FOR CIRCULATION SYSTEMS



Pumped liquid temperature range: from -10 °C to +140 °C (MCE/C) - Maximum ambient temperature: +40 °C

= 1450 1/min

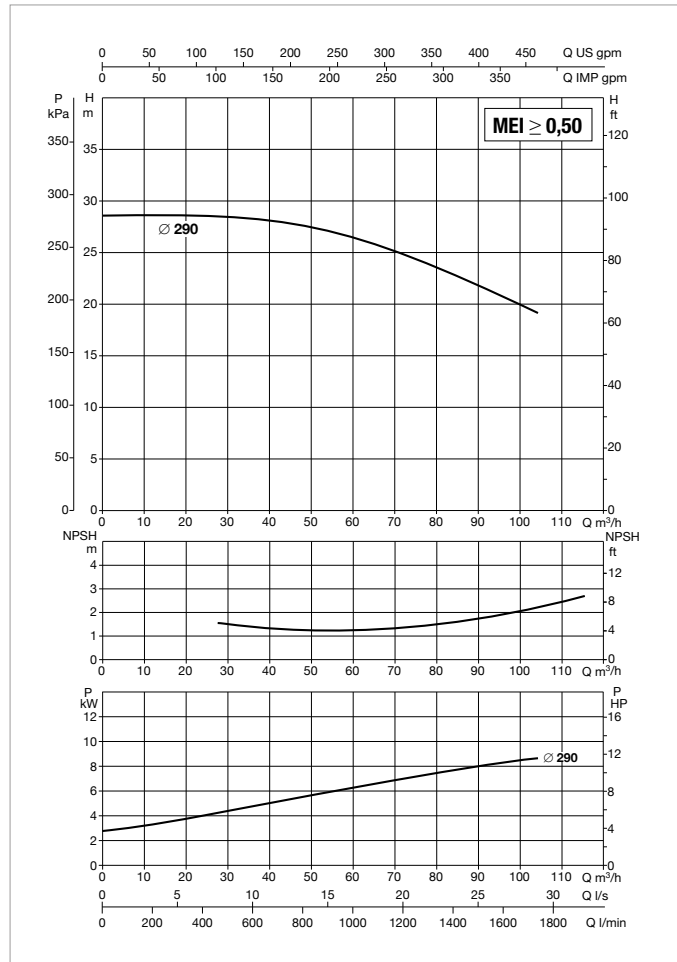
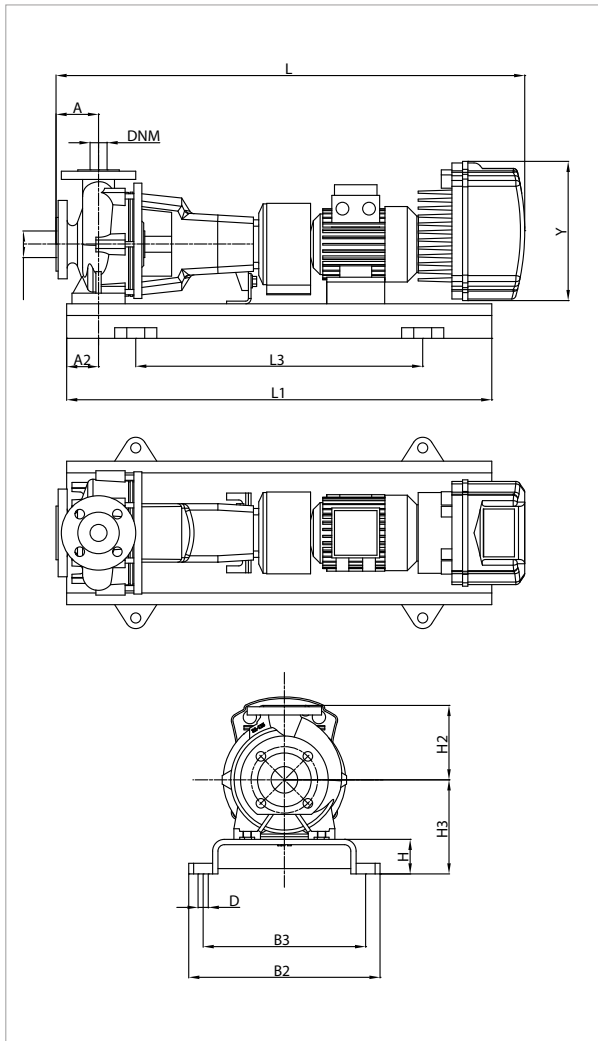

See hydraulic efficiency details on page 241.

The performance curves are based on kinematic viscosity values = 1 mm²/s and density equal to 1000 kg/m³. Curve tolerance according to ISO 9906.

MODEL	MCE MODEL	POWER INPUT 50 Hz	P2 NOMINAL		In A
			kW	HP	
KDNE 65-315/290/A/BAQE/1/11/4 T MCE110/C	MCE110/C	3 x 400 ~V	11	15	27,2

MODEL	A	A2	H2	H	H3	L1	L3	B2	B3	D	Y	FLANGE DIMENSIONS (mm)		STANDARD COUPLING		SPACER COUPLING	
												DNA	DNM	L	WEIGHT kg	L	WEIGHT kg
												KDNE 65-315/290/A/BAQE/1/11/4 T MCE110/C	125	90	280	80	305

KDNE 65-315 - 4 POLES - STANDARDISED CENTRIFUGAL ELECTRIC PUMPS WITH INVERTER FOR PRESSURISATION SYSTEMS



Pumped liquid temperature range: from -10 °C to +80 °C (MCE/P) - Maximum ambient temperature: +40 °C

= 1450 1/min

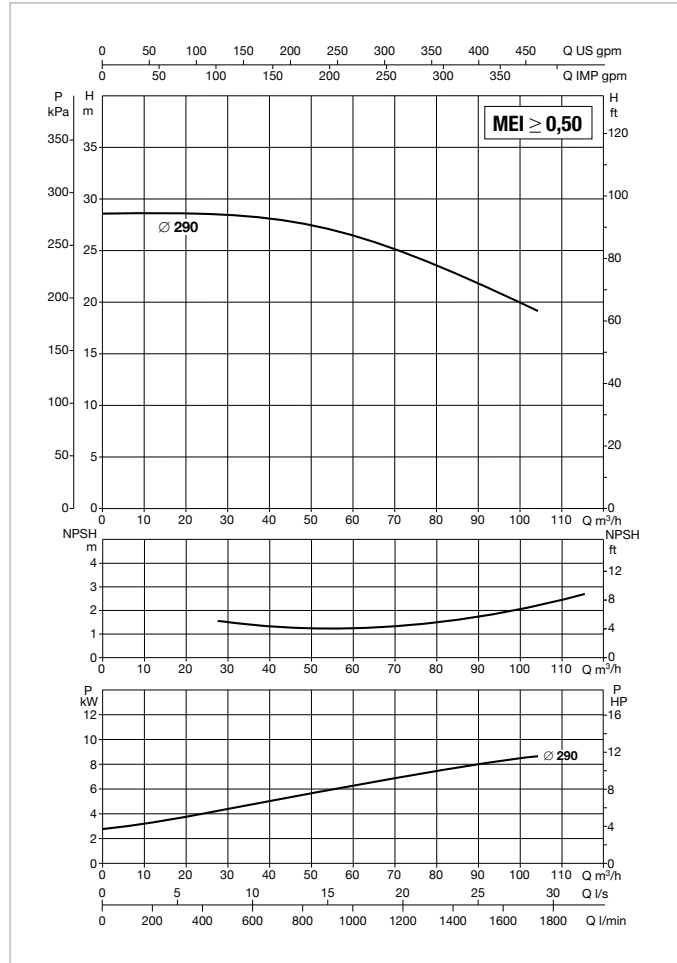
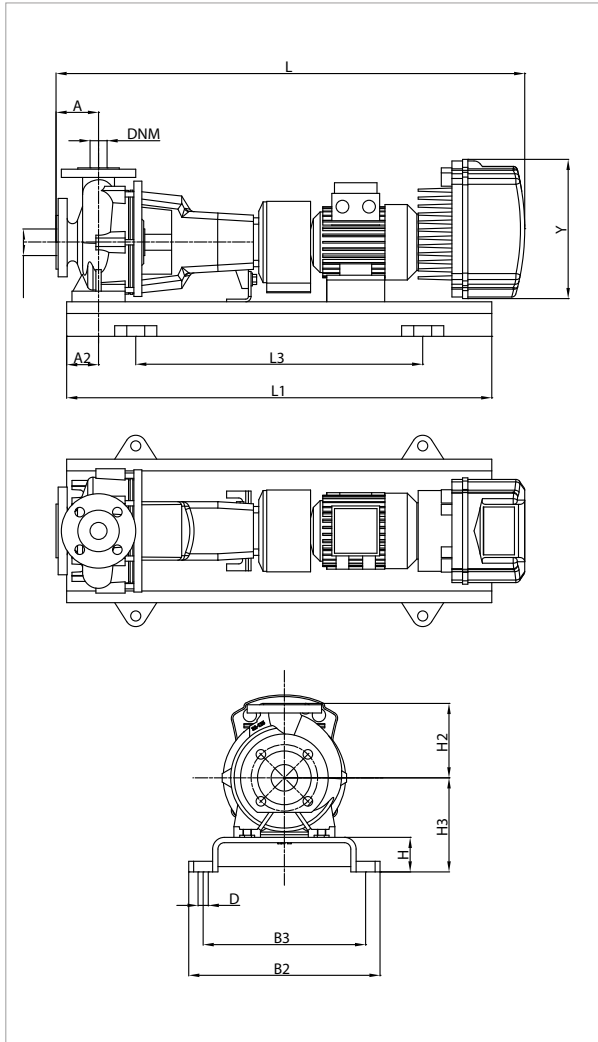

See hydraulic efficiency details on page 241.

The performance curves are based on kinematic viscosity values = 1 mm²/s and density equal to 1000 kg/m³. Curve tolerance according to ISO 9906.

MODEL	MCE MODEL	POWER INPUT 50 Hz	P2 NOMINAL		In A
			kW	HP	
KDNE 65-315/290/A/BAQE/1/11/4 MCE150/P	MCE150/P	3 x 400 ~V	11	15	27,2

MODEL	A	A2	H2	H	H3	L1	L3	B2	B3	D	Y	FLANGE DIMENSIONS (mm)		STANDARD COUPLING		SPACER COUPLING	
												DNA	DNM	L	WEIGHT kg	L	WEIGHT kg
												KDNE 65-315/290/A/BAQE/1/11/4 MCE150/P	125	90	280	80	305

KDNE 65-315 - 4 POLES - STANDARDISED CENTRIFUGAL ELECTRIC PUMPS WITH INVERTER FOR CIRCULATION OR PRESSURISATION SYSTEMS

MCE-C

MCE-P

Pumped liquid temperature range: from -10 °C to +140 °C (MCE/C) - from -10 °C to +80 °C (MCE/P) - Maximum ambient temperature: +40 °C = 1450 1/min

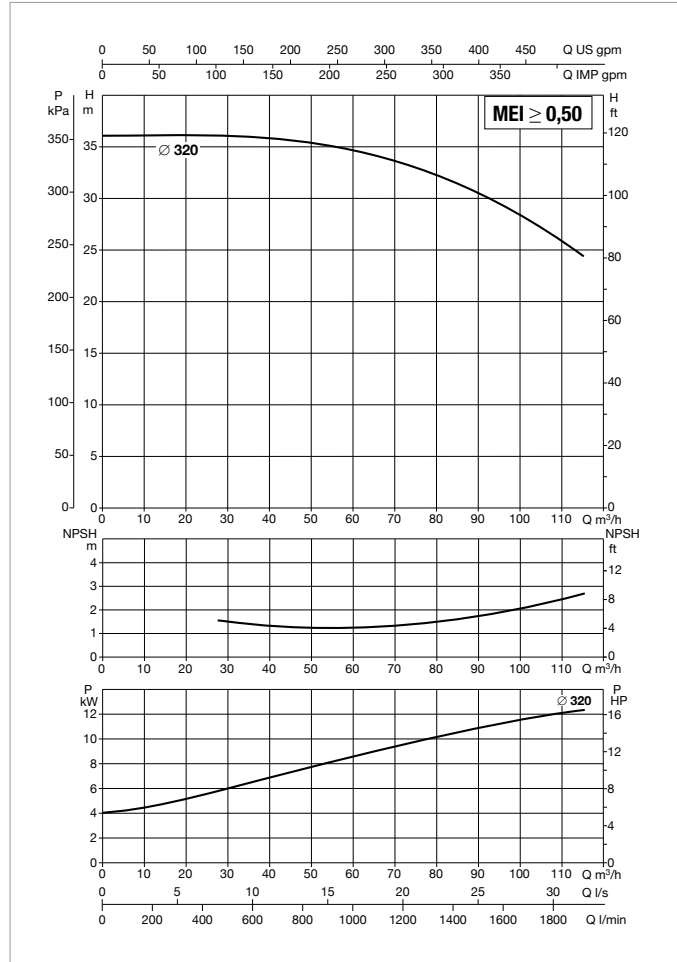
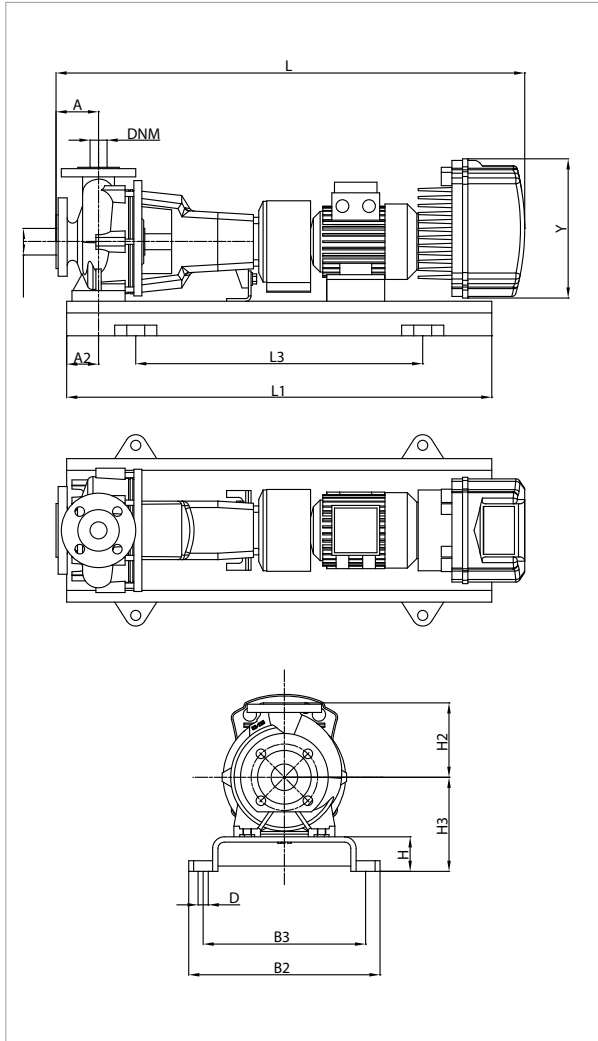

See hydraulic efficiency details on page 241.

The performance curves are based on kinematic viscosity values = 1 mm²/s and density equal to 1000 kg/m³. Curve tolerance according to ISO 9906.

MODEL	MCE MODEL	POWER INPUT 50 Hz	P2 NOMINAL		In A
			kW	HP	
KDNE 65-315/320/A/BAQE/1/15/4 T MCE150/C-P	MCE150/C - MCE150/P	3 x 400 ~V	15	20	36,5

MODEL	A	A2	H2	H	H3	L1	L3	B2	B3	D	Y	FLANGE DIMENSIONS (mm)		STANDARD COUPLING		SPACER COUPLING	
												DNA	DNM	L	WEIGHT kg	L	WEIGHT kg
												KDNE 65-315/320/A/BAQE/1/15/4 T MCE150/C-P	125	90	280	100	325

KDNE 80-160 - 4 POLES - STANDARDISED CENTRIFUGAL ELECTRIC PUMPS WITH INVERTER FOR CIRCULATION SYSTEMS



Pumped liquid temperature range: from -10 °C to +140 °C (MCE/C) - Maximum ambient temperature: +40 °C

= 1450 1/min

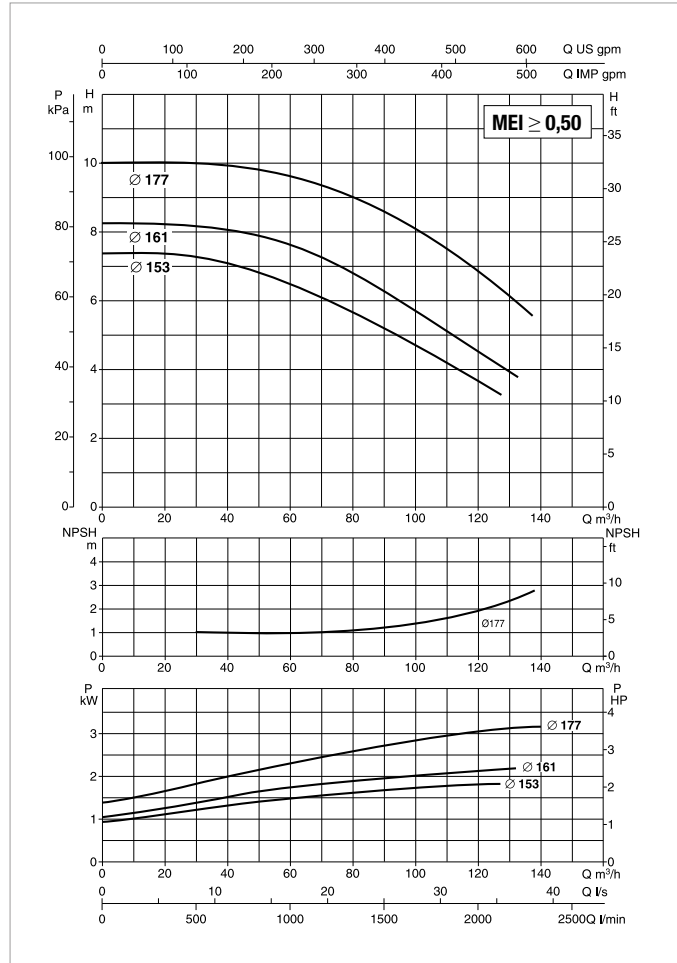
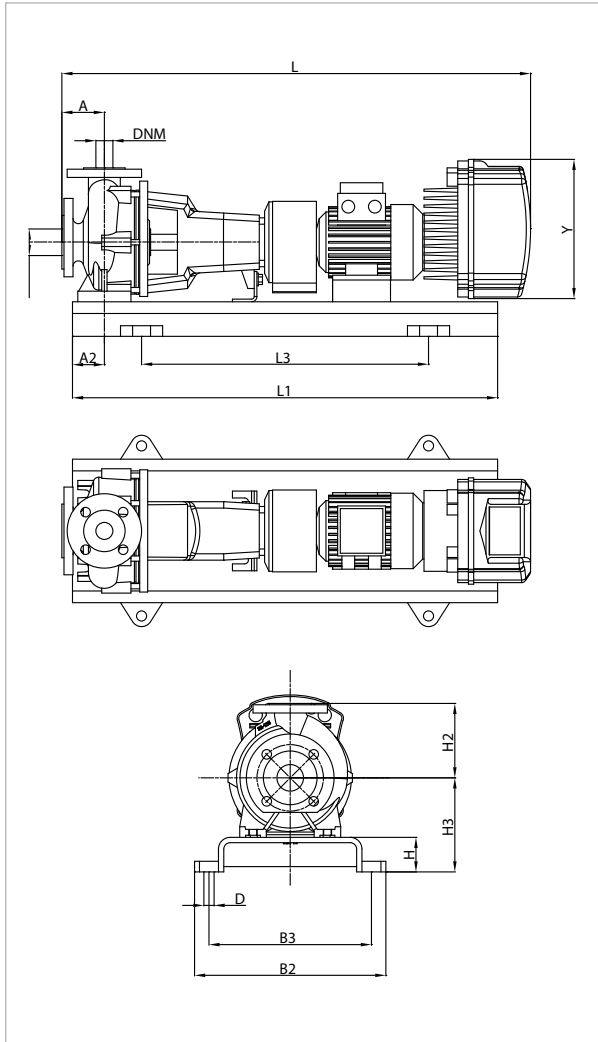

See hydraulic efficiency details on page 241.

The performance curves are based on kinematic viscosity values = 1 mm²/s and density equal to 1000 kg/m³. Curve tolerance according to ISO 9906.

MODEL	MCE MODEL	POWER INPUT 50 Hz	P2 NOMINAL		In A
			kW	HP	
KDNE 80-160/153/A/BAQE/1/2,2/4 M MCE22/C	MCE22/C	1 x 230 ~V	2,2	3	19,7
KDNE 80-160/153/A/BAQE/1/2,2/4 T MCE30/C	MCE30/C	3 x 400 ~V	2,2	3	6,4
KDNE 80-160/161/A/BAQE/1/3/4 T MCE30/C	MCE30/C	3 x 400 ~V	3	4	7,9
KDNE 80-160/177/A/BAQE/1/4/4 T MCE55/C	MCE55/C	3 x 400 ~V	4	5,5	10,0

MODEL	A	A2	H2	H	H3	L1	L3	B2	B3	D	Y	FLANGE DIMENSIONS (mm)		STANDARD COUPLING		SPACER COUPLING	
												DNA	DNM	L	WEIGHT kg	L	WEIGHT kg
												KDNE 80-160/153/A/BAQE/1/2,2/4 M MCE22/C	125	75	225	80	260
KDNE 80-160/153/A/BAQE/1/2,2/4 T MCE30/C	125	75	225	80	260	1000	660	450	400	24	353	100	80	1138	145,6	1238	150,6
KDNE 80-160/161/A/BAQE/1/3/4 T MCE30/C	125	75	225	80	260	1000	660	450	400	24	353	100	80	1071	147	1171	152
KDNE 80-160/177/A/BAQE/1/4/4 T MCE55/C	125	75	225	80	260	1000	660	450	400	24	353	100	80	1094	147	1194	152

KDNE 80-200 - 4 POLES - STANDARDISED CENTRIFUGAL ELECTRIC PUMPS WITH INVERTER FOR CIRCULATION SYSTEMS



Pumped liquid temperature range: from -10 °C to +140 °C (MCE/C) - Maximum ambient temperature: +40 °C

= 1450 1/min

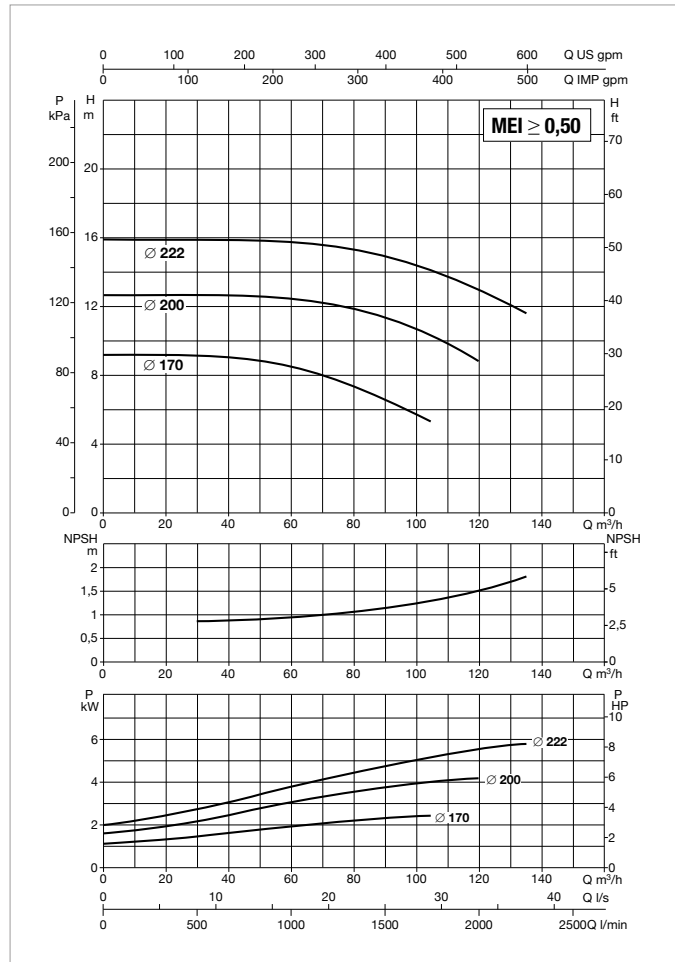
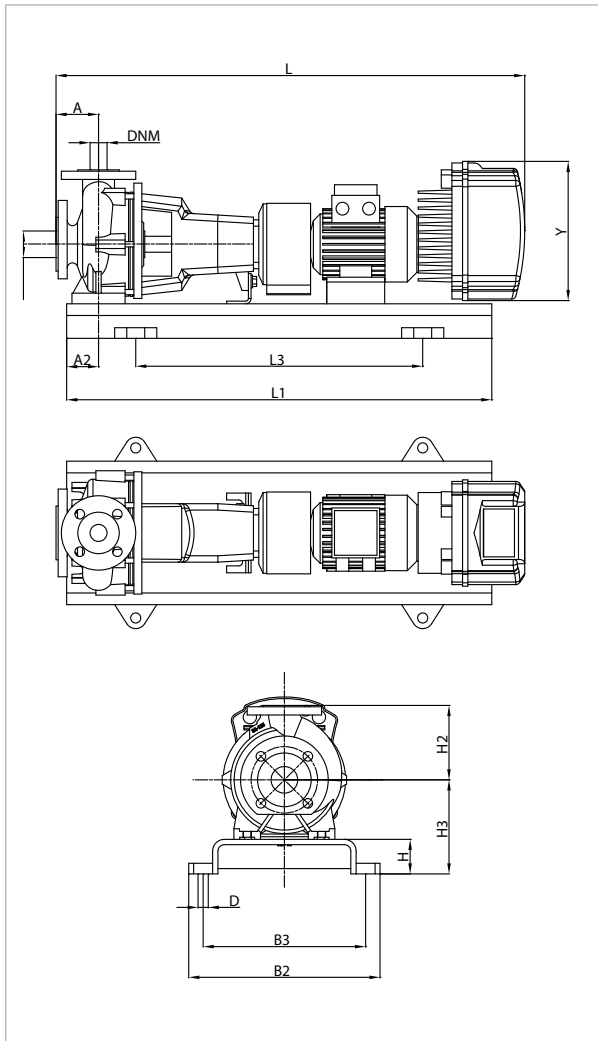

See hydraulic efficiency details on page 241.
The performance curves are based on kinematic viscosity values = 1 mm²/s and density equal to 1000 kg/m³. Curve tolerance according to ISO 9906.

MODEL	MCE MODEL	POWER INPUT 50 Hz	P2 NOMINAL		In A
			kW	HP	
KDNE 80-200/170/A/BAQE/1/3/4 T MCE30/C	MCE30/C	3 x 400 ~V	3	4	7,9
KDNE 80-200/200/A/BAQE/1/5.5/4 T MCE55/C	MCE55/C	3 x 400 ~V	5,5	7,5	13,4
KDNE 80-200/222/A/BAQE/1/7.5/4 T MCE110/C	MCE110/C	3 x 400 ~V	7,5	10	17,9

MODEL	A	A2	H2	H	H3	L1	L3	B2	B3	D	Y	FLANGE DIMENSIONS (mm)		STANDARD COUPLING		SPACER COUPLING	
												DNA	DNM	L	WEIGHT kg	L	WEIGHT kg
												KDNE 80-200/170/A/BAQE/1/3/4 T MCE30/C	125	75	250	80	260
KDNE 80-200/200/A/BAQE/1/5.5/4 T MCE55/C	125	75	250	80	260	1120	740	490	440	24	353	100	80	1314	197	1414	202
KDNE 80-200/222/A/BAQE/1/7.5/4 T MCE110/C	125	75	250	80	260	1120	740	490	440	24	426	100	80	1364	201	1464	206

KDNE 80-250 - 4 POLES - STANDARDISED CENTRIFUGAL ELECTRIC PUMPS WITH INVERTER FOR CIRCULATION OR PRESSURISATION SYSTEMS



Pumped liquid temperature range: from -10 °C to +140 °C (MCE/C) - from -10 °C to +80 °C (MCE/P) - Maximum ambient temperature: +40 °C
= 1450 l/min

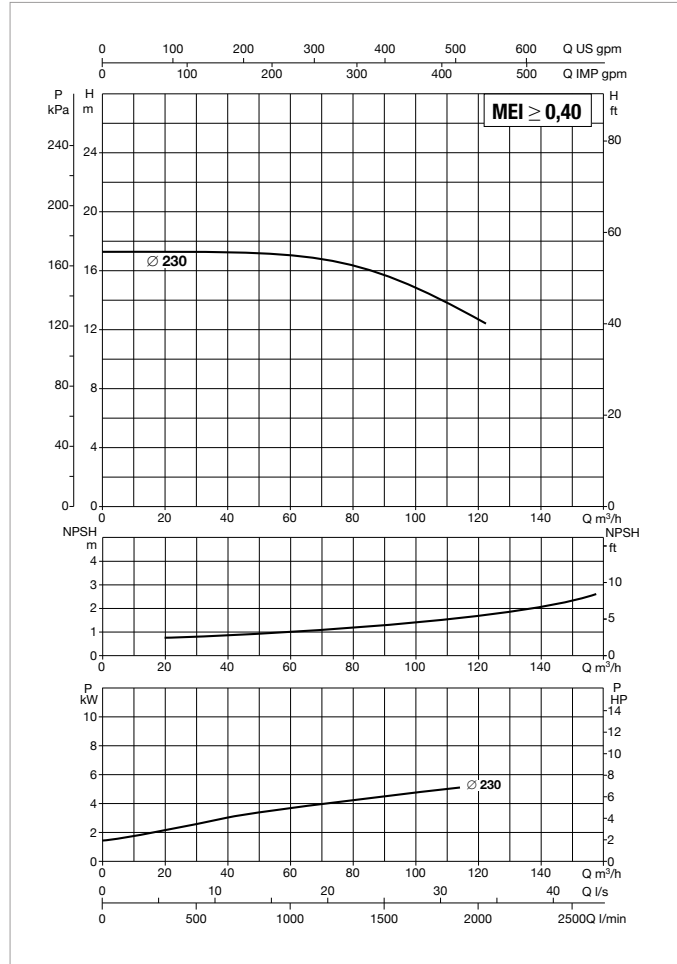
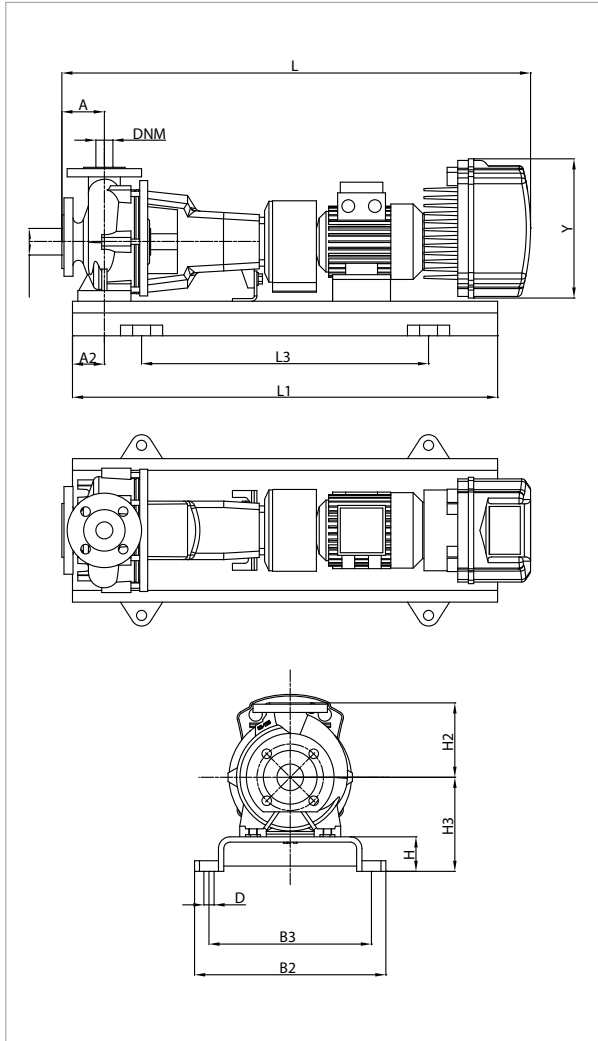

See hydraulic efficiency details on page 241.

The performance curves are based on kinematic viscosity values = 1 mm²/s and density equal to 1000 kg/m³. Curve tolerance according to ISO 9906.

MODEL	MCE MODEL	POWER INPUT 50 Hz	P2 NOMINAL		In A
			kW	HP	
KDNE 80-250/230/A/BAQE/1/7,5/4 T MCE110/C-P	MCE110/C - MCE110/P	3 x 400 ~V	7,5	10	17,9

MODEL	A	A2	H2	H	H3	L1	L3	B2	B3	D	Y	FLANGE DIMENSIONS (mm)		STANDARD COUPLING		SPACER COUPLING	
												DNA	DNM	L	WEIGHT kg	L	WEIGHT kg
												KDNE 80-250/230/A/BAQE/1/7,5/4 T MCE110/C-P	125	90	280	80	280

KDNE 80-250 - 4 POLES - STANDARDISED CENTRIFUGAL ELECTRIC PUMPS WITH INVERTER FOR CIRCULATION SYSTEMS



Pumped liquid temperature range: from -10 °C to +140 °C (MCE/C) - Maximum ambient temperature: +40 °C

= 1450 1/min

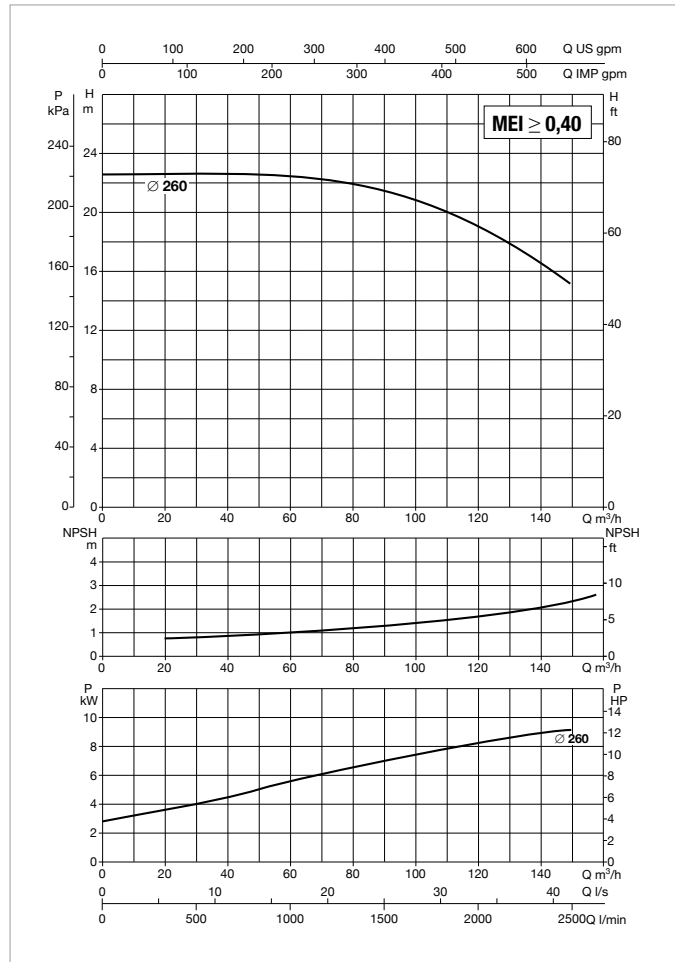
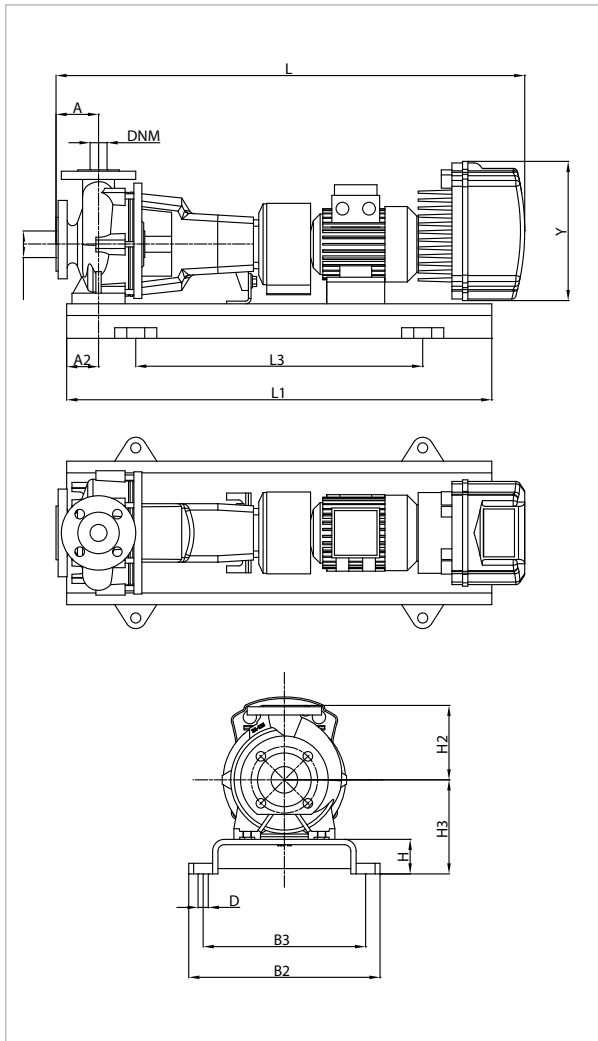

See hydraulic efficiency details on page 241.

The performance curves are based on kinematic viscosity values = 1 mm²/s and density equal to 1000 kg/m³. Curve tolerance according to ISO 9906.

MODEL	MCE MODEL	POWER INPUT 50 Hz	P2 NOMINAL		In A
			kW	HP	
KDNE 80-250/260/A/BAQE/1/11/4 T MCE110/C	MCE110/C	3 x 400 ~V	11	15	27,2

MODEL	A	A2	H2	H	H3	L1	L3	B2	B3	D	Y	FLANGE DIMENSIONS (mm)		STANDARD COUPLING		SPACER COUPLING	
												DNA	DNM	L	WEIGHT kg	L	WEIGHT kg
												KDNE 80-250/260/A/BAQE/1/11/4 T MCE110/C	125	90	280	80	280

KDNE 80-250 - 4 POLES - STANDARDISED CENTRIFUGAL ELECTRIC PUMPS WITH INVERTER FOR PRESSURISATION SYSTEMS



Pumped liquid temperature range: from -10 °C to +80 °C (MCE/P) - Maximum ambient temperature: +40 °C

= 1450 1/min

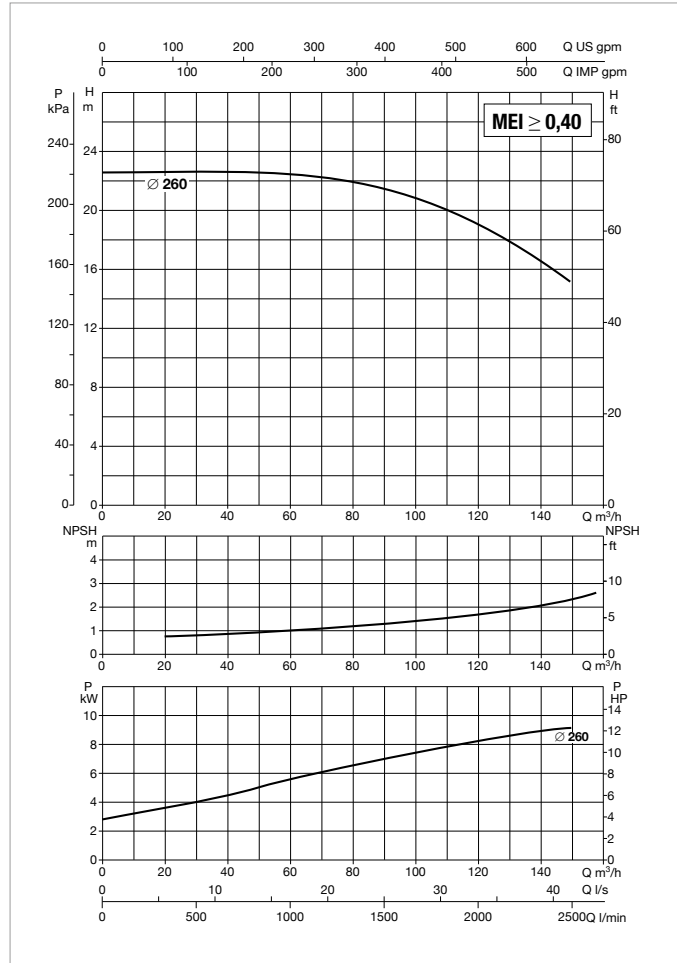
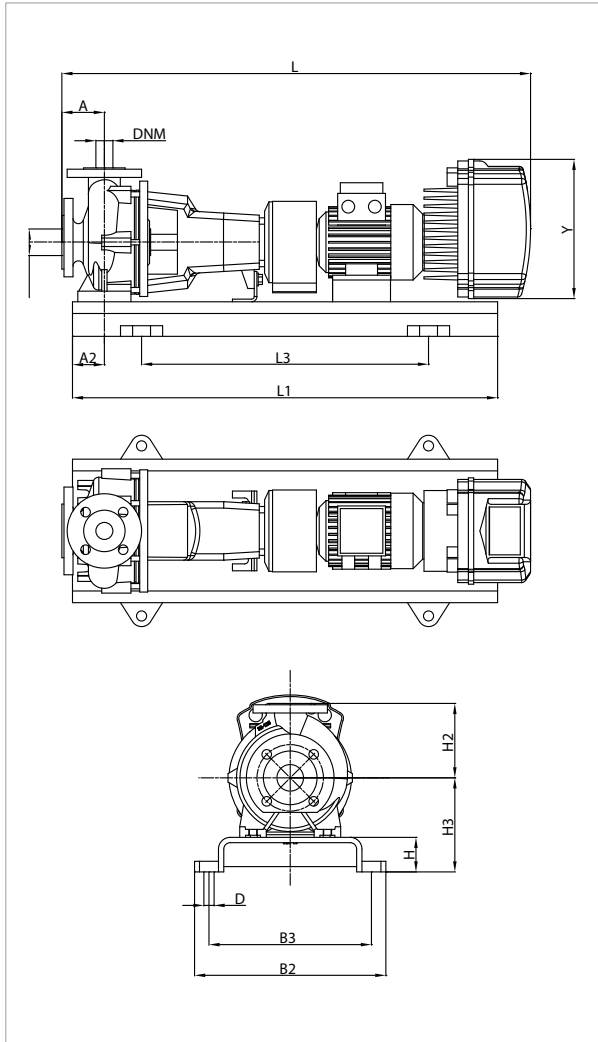

See hydraulic efficiency details on page 241.

The performance curves are based on kinematic viscosity values = 1 mm²/s and density equal to 1000 kg/m³. Curve tolerance according to ISO 9906.

MODEL	MCE MODEL	POWER INPUT 50 Hz	P2 NOMINAL		In A
			kW	HP	
KDNE 80-250/260/A/BAQE/1/11/4 MCE150/P	MCE150/P	3 x 400 ~V	11	15	27,2

MODEL	A	A2	H2	H	H3	L1	L3	B2	B3	D	Y	FLANGE DIMENSIONS (mm)		STANDARD COUPLING		SPACER COUPLING	
												DNA	DNM	L	WEIGHT kg	L	WEIGHT kg
												KDNE 80-250/260/A/BAQE/1/11/4 MCE150/P	125	90	280	80	280

KDNE 80-250 - 4 POLES - STANDARDISED CENTRIFUGAL ELECTRIC PUMPS WITH INVERTER FOR CIRCULATION OR PRESSURISATION SYSTEMS

MCE-C

MCE-P

Pumped liquid temperature range: from -10 °C to +140 °C (MCE/C) - from -10 °C to +80 °C (MCE/P) - Maximum ambient temperature: +40 °C
= 1450 1/min

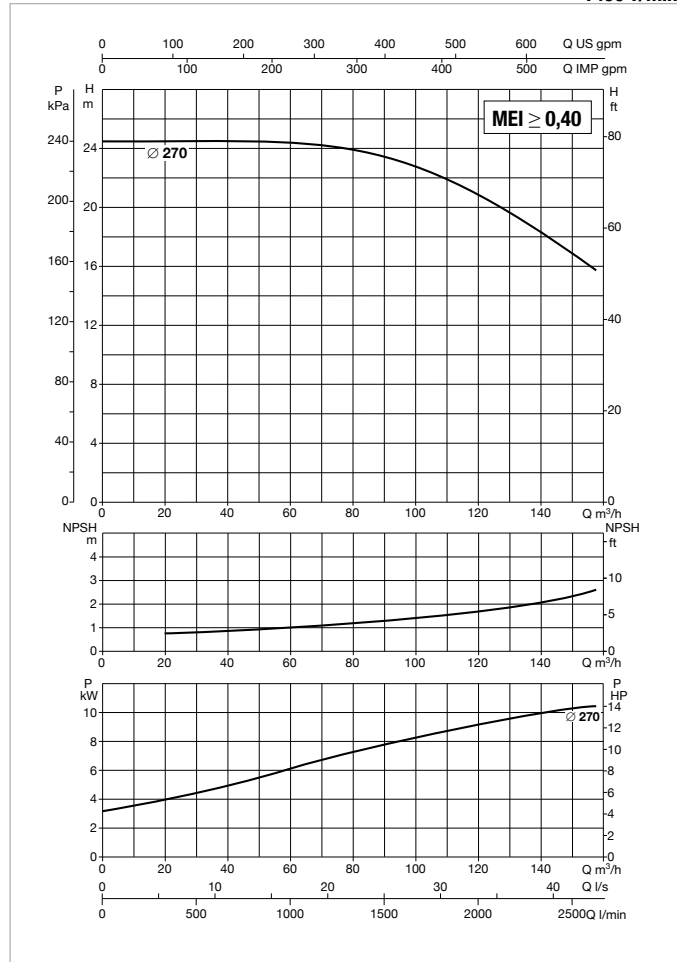
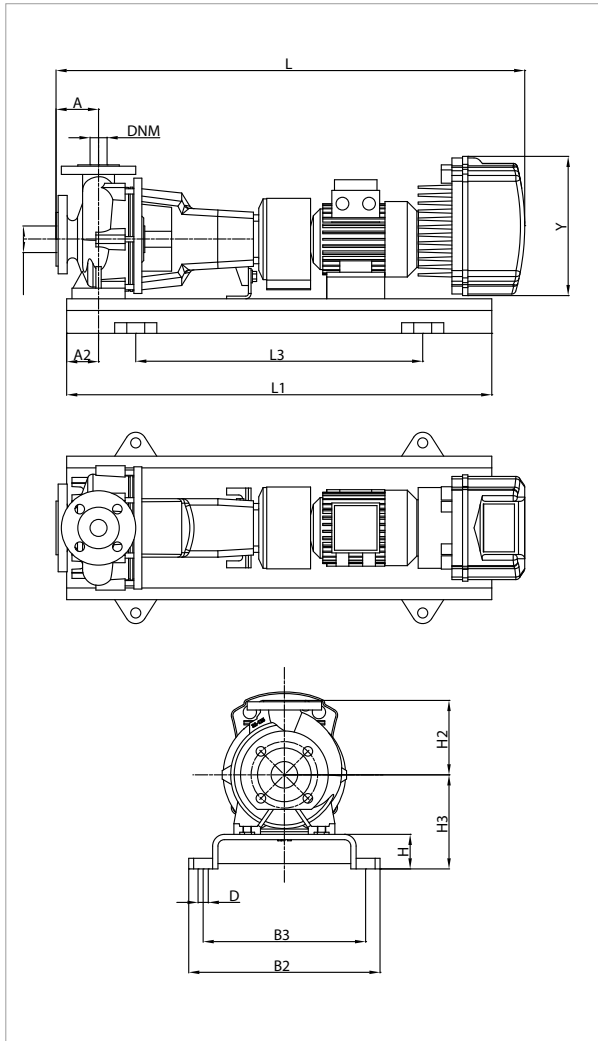

See hydraulic efficiency details on page 241.

The performance curves are based on kinematic viscosity values = 1 mm²/s and density equal to 1000 kg/m³. Curve tolerance according to ISO 9906.

MODEL	MCE MODEL	POWER INPUT 50 Hz	P2 NOMINAL		In A
			kW	HP	
KDNE 80-250/270/A/BAQE/1/15/4 T MCE150/C-P	MCE150/C - MCE150/P	3 x 400 ~V	15	20	36,5

MODEL	A	A2	H2	H	H3	L1	L3	B2	B3	D	Y	FLANGE DIMENSIONS (mm)		STANDARD COUPLING		SPACER COUPLING	
												DNA	DNM	L	WEIGHT kg	L	WEIGHT kg
												KDNE 80-250/270/A/BAQE/1/15/4 T MCE150/C-P	125	90	280	80	280

KDNE 80-315 - 4 POLES - STANDARDISED CENTRIFUGAL ELECTRIC PUMPS WITH INVERTER FOR CIRCULATION OR PRESSURIZATION SYSTEMS



Pumped liquid temperature range: from -10 °C to +140 °C (MCE/C) - from -10 °C to +80 °C (MCE/P) - Maximum ambient temperature: +40 °C = 1450 1/min

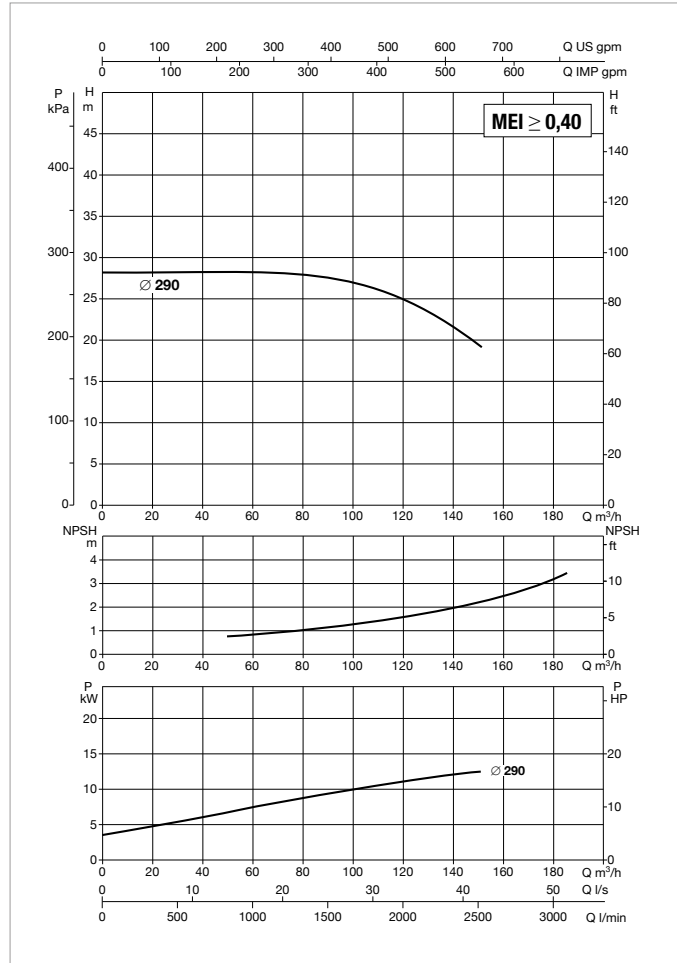
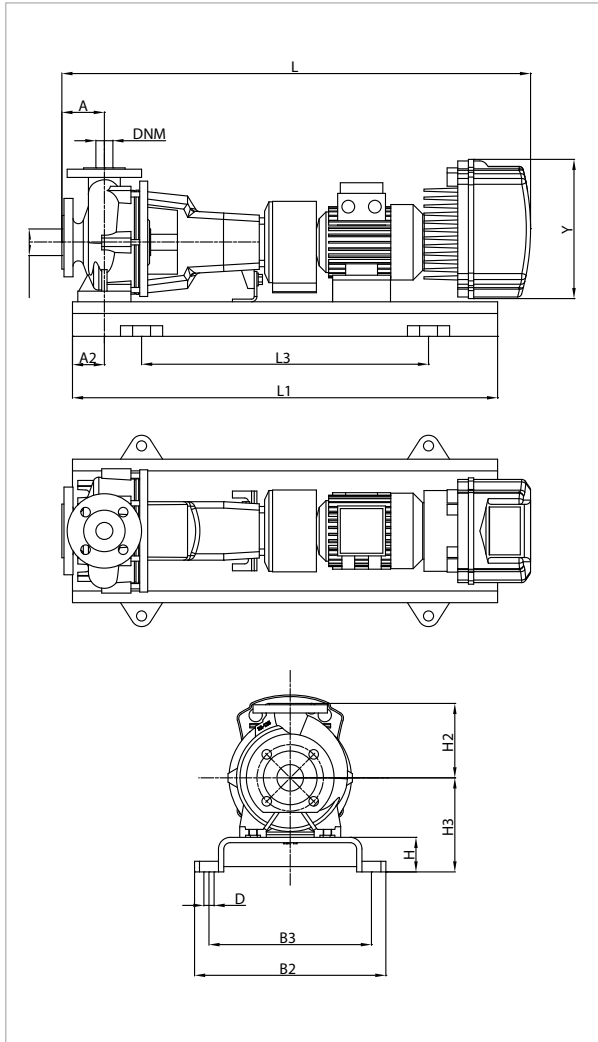

See hydraulic efficiency details on page 241.

The performance curves are based on kinematic viscosity values = 1 mm²/s and density equal to 1000 kg/m³. Curve tolerance according to ISO 9906.

MODEL	MCE MODEL	POWER INPUT 50 Hz	P2 NOMINAL		In A
			kW	HP	
KDNE 80-315/290/A/BAQE/1/15/4 T MCE150/C-P	MCE150/C - MCE150/P	3 x 400 ~V	15	20	36,5

MODEL	A	A2	H2	H	H3	L1	L3	B2	B3	D	Y	FLANGE DIMENSIONS (mm)		STANDARD COUPLING		SPACER COUPLING	
												DNA	DNM	L	WEIGHT kg	L	WEIGHT kg
												KDNE 80-315/290/A/BAQE/1/15/4 T MCE150/C-P	125	90	315	100	350

KDNE 100-200 - 4 POLES - STANDARDISED CENTRIFUGAL ELECTRIC PUMPS WITH INVERTER FOR CIRCULATION SYSTEMS



Pumped liquid temperature range: from -10 °C to +140 °C (MCE/C) - Maximum ambient temperature: +40 °C

= 1450 1/min

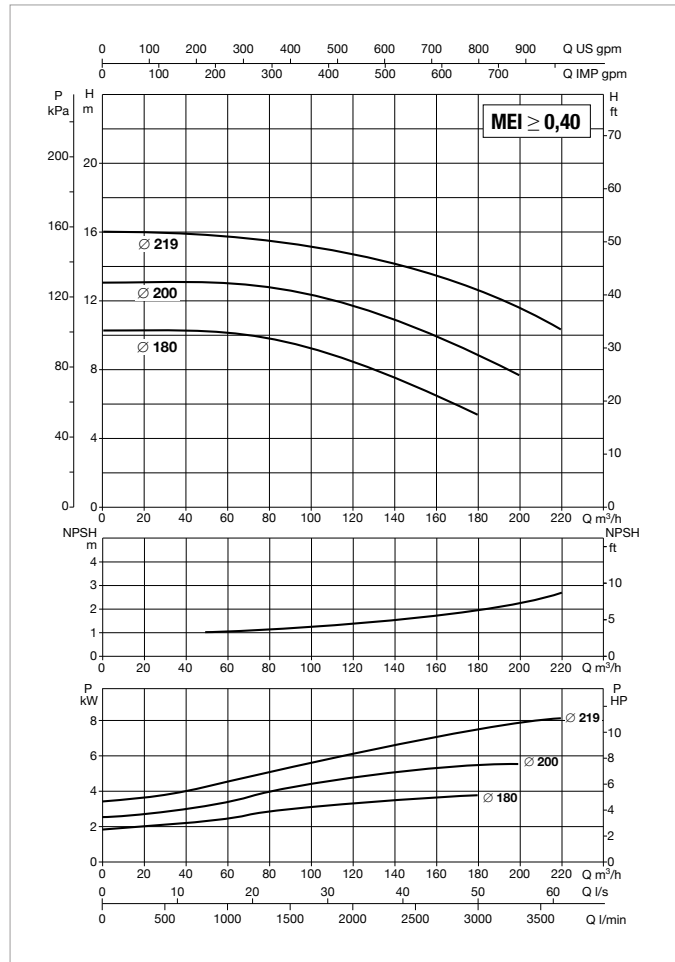
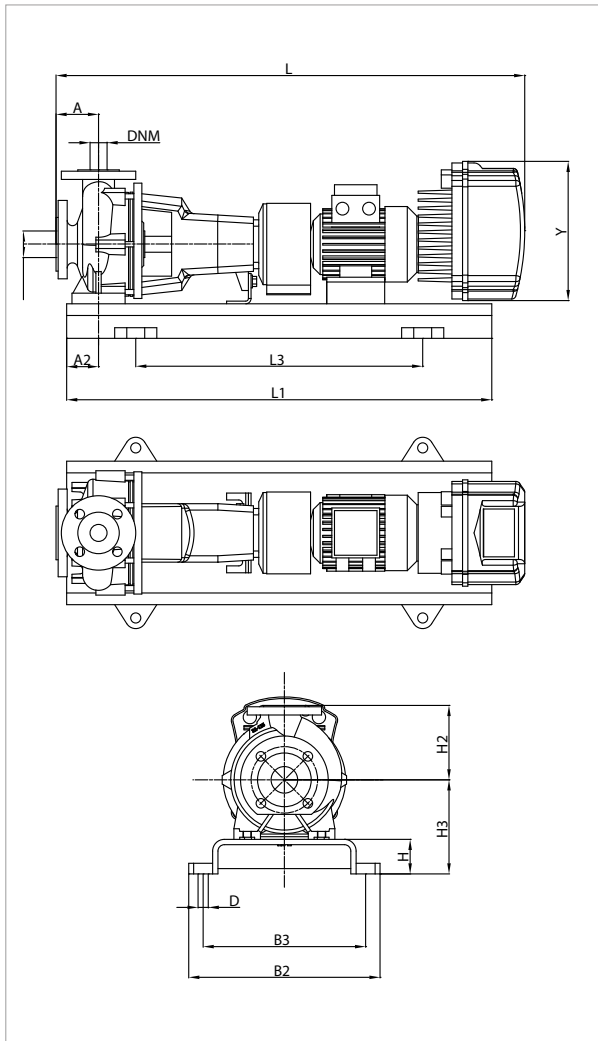

See hydraulic efficiency details on page 241.

The performance curves are based on kinematic viscosity values = 1 mm²/s and density equal to 1000 kg/m³. Curve tolerance according to ISO 9906.

MODEL	MCE MODEL	POWER INPUT 50 Hz	P2 NOMINAL		In A
			kW	HP	
KDNE 100-200/180/A/BAQE/1/5.5/4 T MCE55/C	MCE55/C	3 x 400 ~V	5,5	7,5	13,4
KDNE 100-200/200/A/BAQE/1/7.5/4 T MCE110/C	MCE110/C	3 x 400 ~V	7,5	10	17,9
KDNE 100-200/219/A/BAQE/1/11/4 T MCE110/C	MCE110/C	3 x 400 ~V	11	15	27,2

MODEL	A	A2	H2	H	H3	L1	L3	B2	B3	D	Y	FLANGE DIMENSIONS (mm)		STANDARD COUPLING		SPACER COUPLING	
												DNA	DNM	L	WEIGHT kg	L	WEIGHT kg
												KDNE 100-200/180/A/BAQE/1/5.5/4 T MCE55/C	125	90	280	80	280
KDNE 100-200/200/A/BAQE/1/7.5/4 T MCE110/C	125	90	280	80	280	1120	740	490	440	24	426	125	100	1364	222	1504	227
KDNE 100-200/219/A/BAQE/1/11/4 T MCE110/C	125	90	280	80	280	1250	840	540	490	24	426	125	100	1474	320	1614	325

KDNE 100-250 - 4 POLES - STANDARDISED CENTRIFUGAL ELECTRIC PUMPS WITH INVERTER FOR CIRCULATION SYSTEMS

MCE-C

Pumped liquid temperature range: from -10 °C to +140 °C (MCE/C) - Maximum ambient temperature: +40 °C

= 1450 1/min

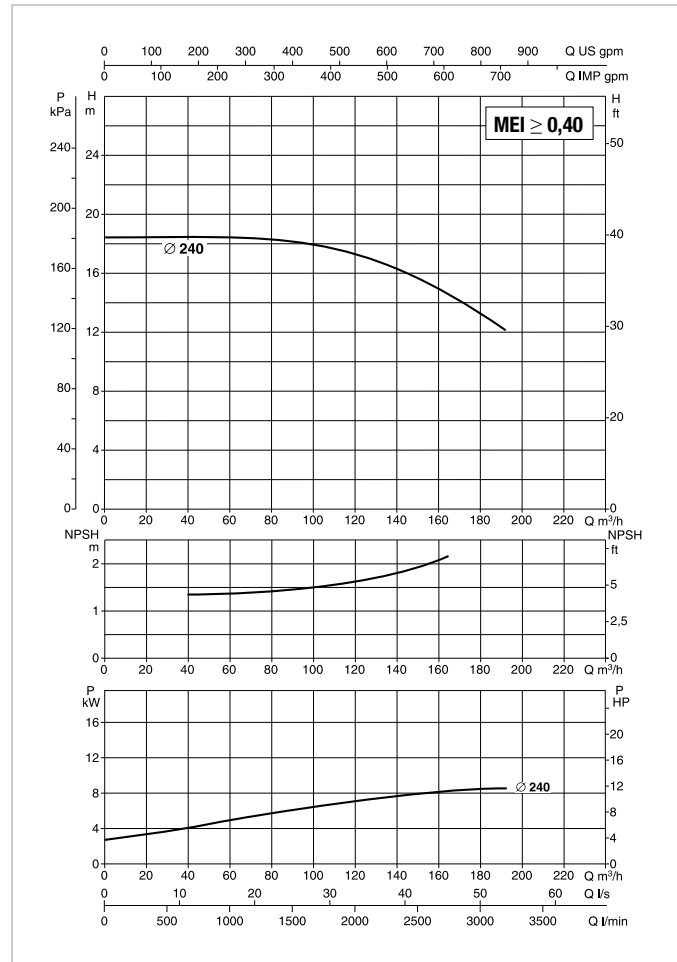
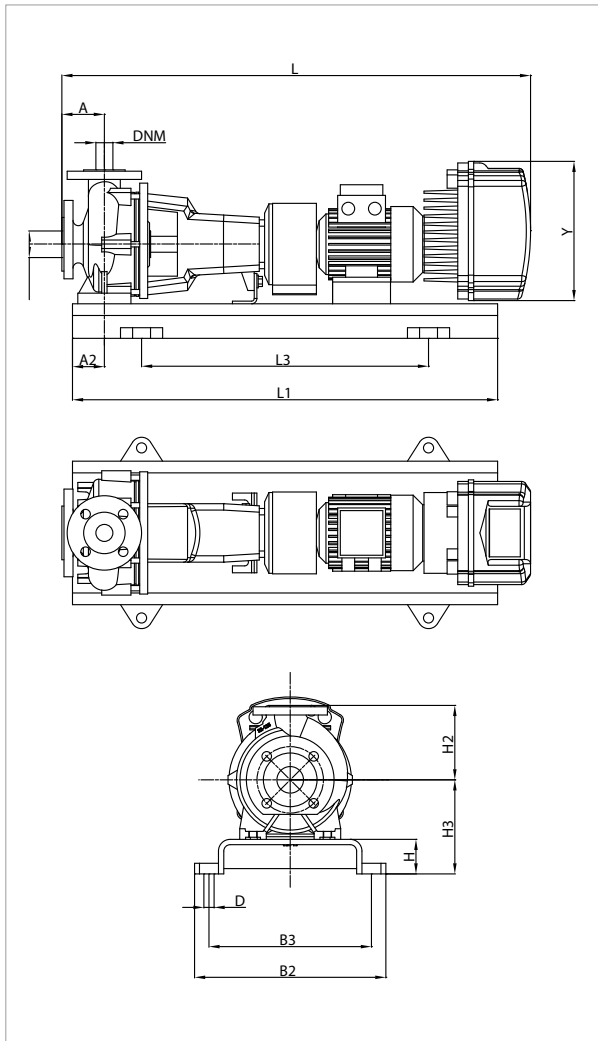

See hydraulic efficiency details on page 241.

The performance curves are based on kinematic viscosity values = 1 mm²/s and density equal to 1000 kg/m³. Curve tolerance according to ISO 9906.

MODEL	MCE MODEL	POWER INPUT 50 Hz	P2 NOMINAL		In A
			kW	HP	
KDNE 100-250/240/A/BAQE/1/11/4 T MCE110/C	MCE110/C	3 x 400 ~V	11	15	27,2

MODEL	A	A2	H2	H	H3	L1	L3	B2	B3	D	Y	FLANGE DIMENSIONS (mm)		STANDARD COUPLING		SPACER COUPLING	
												DNA	DNM	L	WEIGHT kg	L	WEIGHT kg
												KDNE 100-250/240/A/BAQE/1/11/4 T MCE110/C	140	90	280	80	305

KDNE 100-250 - 4 POLES - STANDARDISED CENTRIFUGAL ELECTRIC PUMPS WITH INVERTER FOR CIRCULATION OR PRESSURISATION SYSTEMS

MCE-C

MCE-P

Pumped liquid temperature range: from -10 °C to +140 °C (MCE/C) - from -10 °C to +80 °C (MCE/P) - Maximum ambient temperature: +40 °C
= 1450 1/min

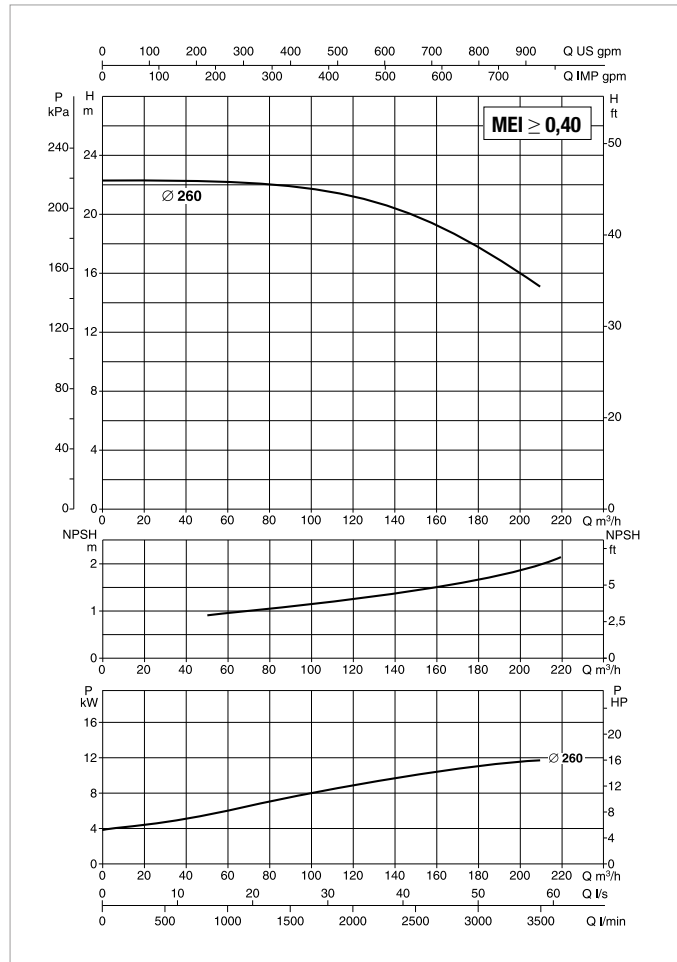
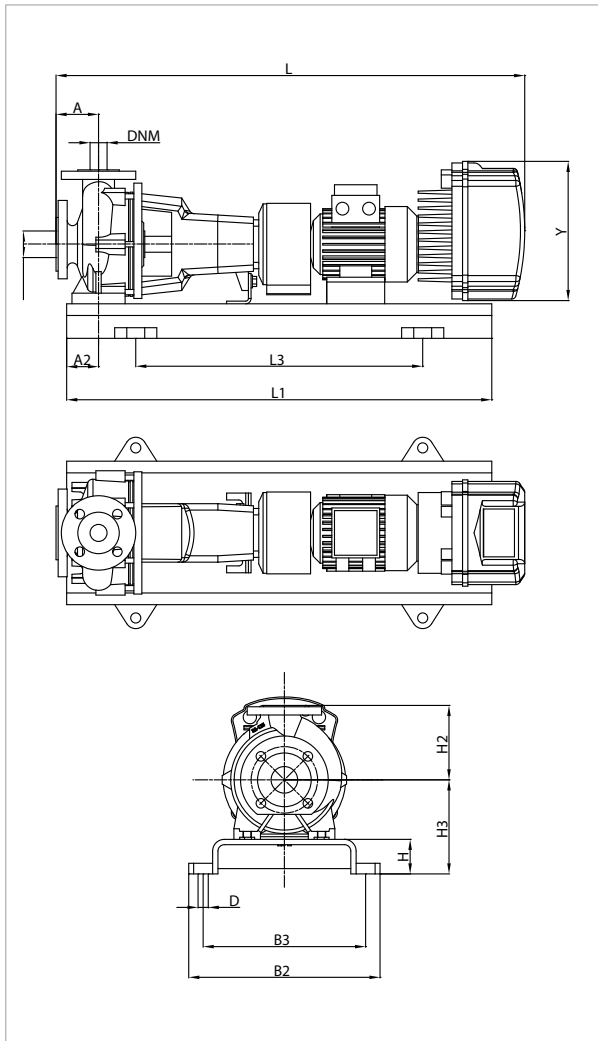

See hydraulic efficiency details on page 241.

The performance curves are based on kinematic viscosity values = 1 mm²/s and density equal to 1000 kg/m³. Curve tolerance according to ISO 9906.

MODEL	MCE MODEL	POWER INPUT 50 Hz	P2 NOMINAL		In A
			kW	HP	
KDNE 100-250/260/A/BAQE/1/15/4 T MCE150/C-P	MCE150/C - MCE150/P	3 x 400 ~V	15	20	36,5

MODEL	A	A2	H2	H	H3	L1	L3	B2	B3	D	Y	FLANGE DIMENSIONS (mm)		STANDARD COUPLING		SPACER COUPLING	
												DNA	DNM	L	WEIGHT kg	L	WEIGHT kg
												KDNE 100-250/260/A/BAQE/1/15/4 T MCE150/C-P	140	90	280	100	325

KDNE 100-315 - 4 POLES - STANDARDISED CENTRIFUGAL ELECTRIC PUMPS WITH INVERTER FOR CIRCULATION OR PRESSURISATION SYSTEMS



Pumped liquid temperature range: from -10 °C to +140 °C (MCE/C) - from -10 °C to +80 °C (MCE/P) - Maximum ambient temperature: +40 °C
= 1450 l/min

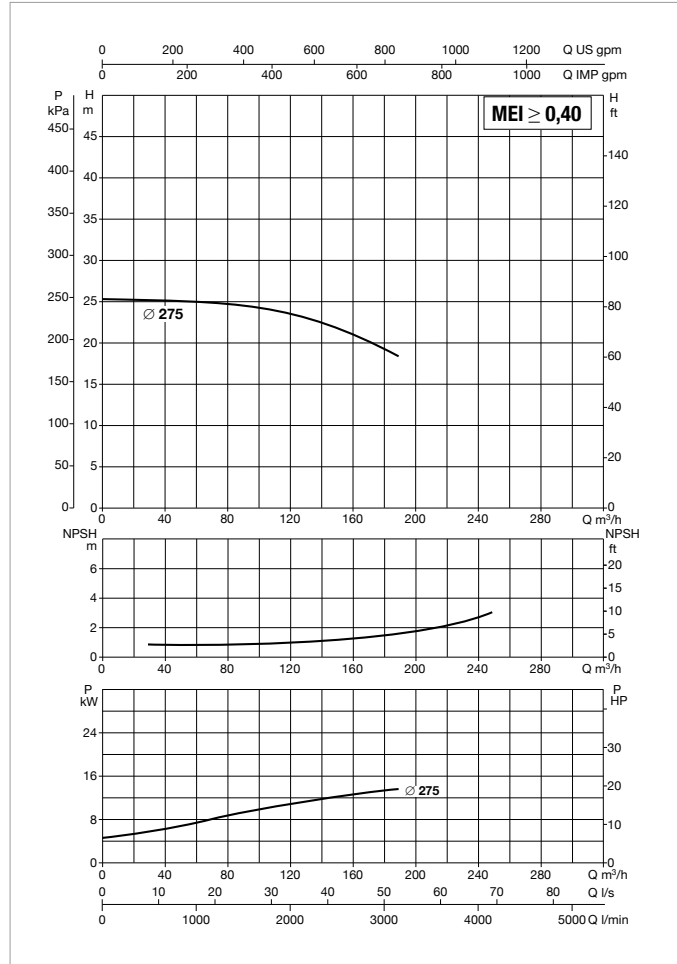
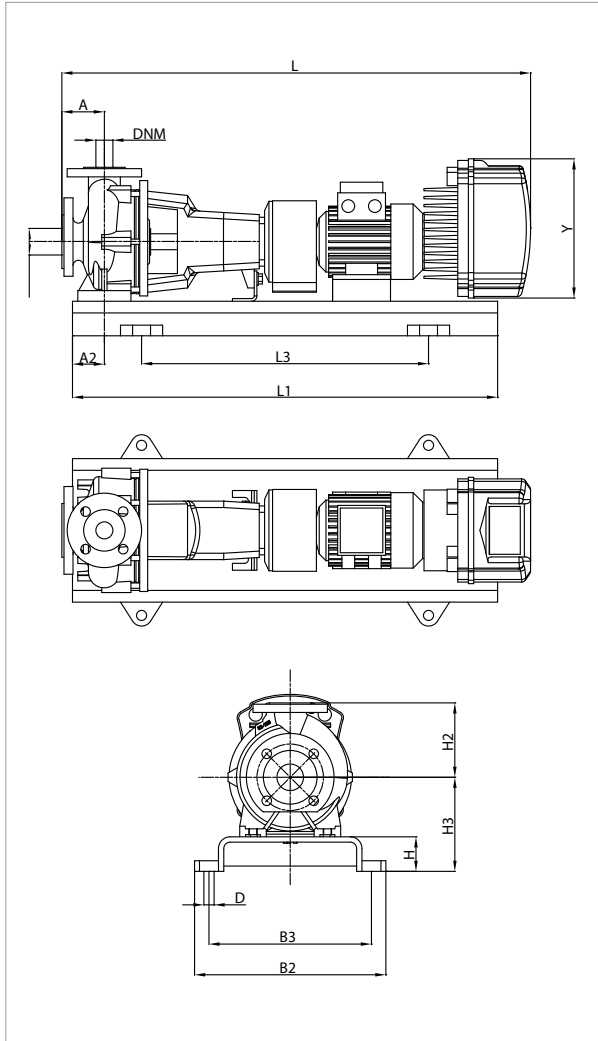

See hydraulic efficiency details on page 241.

The performance curves are based on kinematic viscosity values = 1 mm²/s and density equal to 1000 kg/m³. Curve tolerance according to ISO 9906.

MODEL	MCE MODEL	POWER INPUT 50 Hz	P2 NOMINAL		In A
			kW	HP	
KDNE 100-315/275/A/BAQE/1/15/4 T MCE150/C-P	MCE150/C - MCE150/P	3 x 400 ~V	15	20	36,5

MODEL	A	A2	H2	H	H3	L1	L3	B2	B3	D	Y	FLANGE DIMENSIONS (mm)		STANDARD COUPLING		SPACER COUPLING	
												DNA	DNM	L	WEIGHT kg	L	WEIGHT kg
												KDNE 100-315/275/A/BAQE/1/15/4 T MCE150/C-P	140	90	315	100	350

KDNE 125-250 - 4 POLES - STANDARDISED CENTRIFUGAL ELECTRIC PUMPS WITH INVERTER FOR CIRCULATION SYSTEMS



Pumped liquid temperature range: from -10 °C to +140 °C (MCE/C) - Maximum ambient temperature: +40 °C

= 1450 1/min

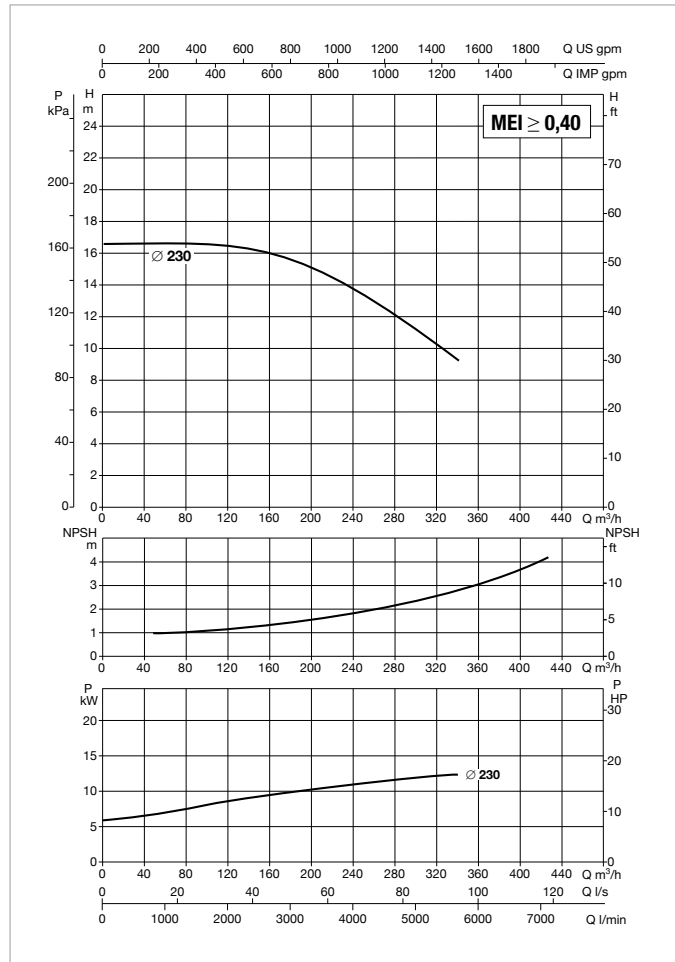
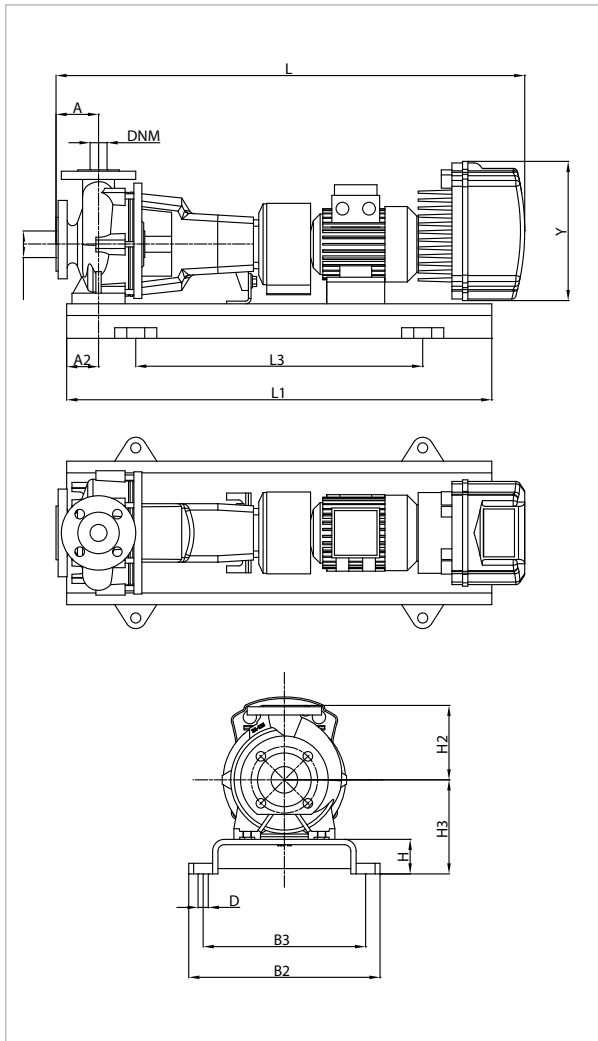

See hydraulic efficiency details on page 241.

The performance curves are based on kinematic viscosity values = 1 mm²/s and density equal to 1000 kg/m³. Curve tolerance according to ISO 9906.

MODEL	MCE MODEL	POWER INPUT 50 Hz	P2 NOMINAL		In A
			kW	HP	
KDNE 125-250/230/A/BAQE/1/15/4 T MCE150/C	MCE150/C	3 x 400 ~V	15	20	36,5

MODEL	A	A2	H2	H	H3	L1	L3	B2	B3	D	Y	FLANGE DIMENSIONS (mm)		STANDARD COUPLING		SPACER COUPLING	
												DNA	DNM	L	WEIGHT kg	L	WEIGHT kg
												KDNE 125-250/230/A/BAQE/1/15/4 T MCE150/C	140	90	355	100	350

KDNE 150-200 - 4 POLES - STANDARDISED CENTRIFUGAL ELECTRIC PUMPS WITH INVERTER FOR CIRCULATION SYSTEMS



Pumped liquid temperature range: from -10 °C to +140 °C (MCE/C) - Maximum ambient temperature: +40 °C

= 1450 1/min

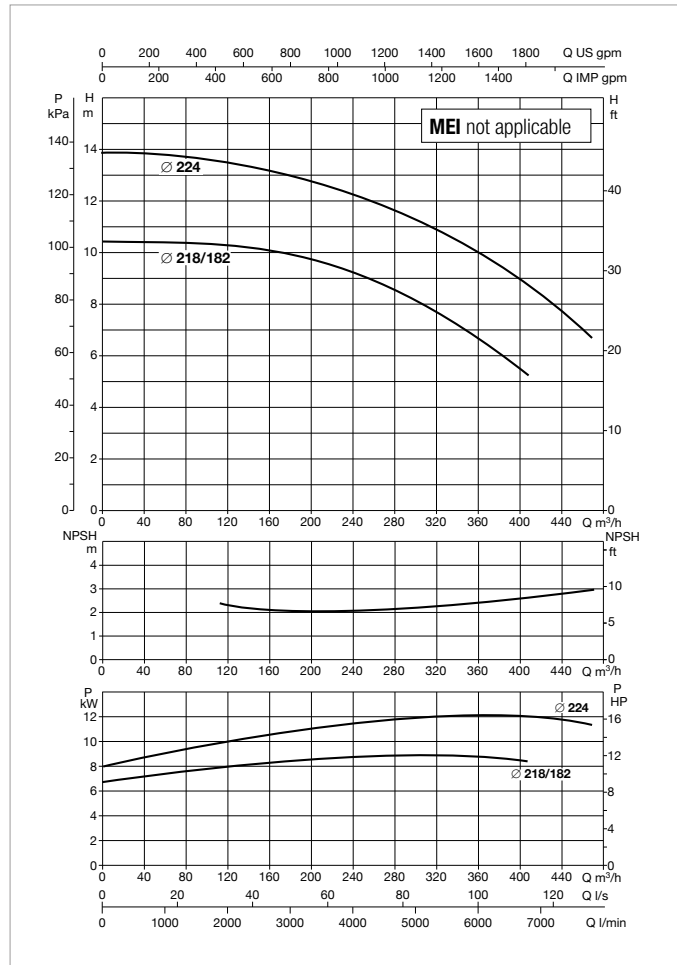
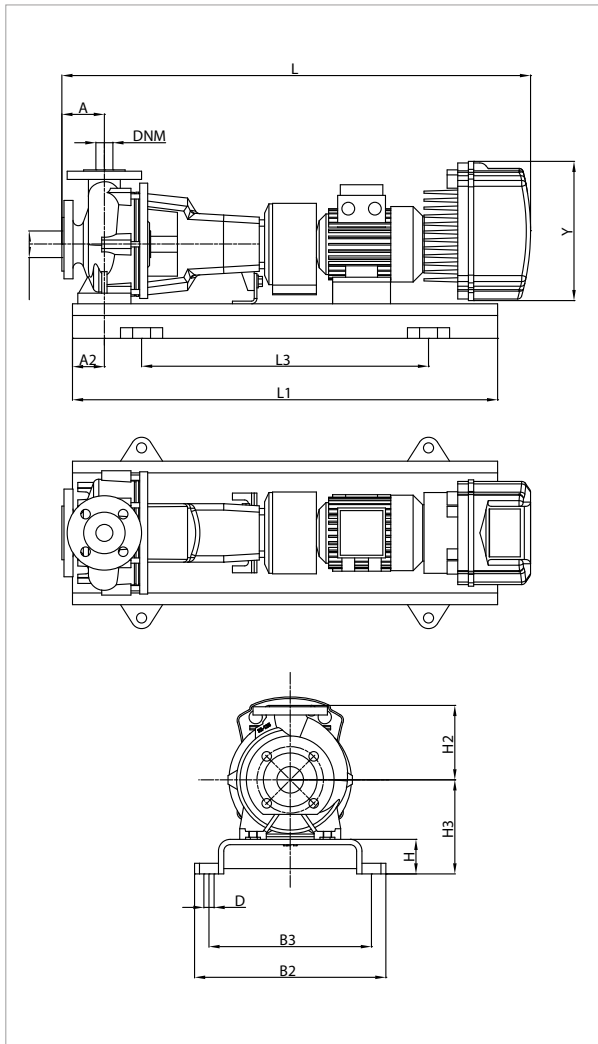

See hydraulic efficiency details on page 241.

The performance curves are based on kinematic viscosity values = 1 mm²/s and density equal to 1000 kg/m³. Curve tolerance according to ISO 9906.

MODEL	MCE MODEL	POWER INPUT 50 Hz	P2 NOMINAL		In A
			kW	HP	
KDNE 150-200/218-182/A/BAQE/1/11/4 T MCE110/C	MCE110/C	3 x 400 ~V	11	15	27,2
KDNE 150-200/224/A/BAQE/1/15/4 T MCE150/C	MCE150/C	3 x 400 ~V	15	20	36,5

MODEL	A	A2	H2	H	H3	L1	L3	B2	B3	D	Y	FLANGE DIMENSIONS (mm)		STANDARD COUPLING		SPACER COUPLING	
												DNA	DNM	L	WEIGHT kg	L	WEIGHT kg
												KDNE 150-200/218-182/A/BAQE/1/11/4 T MCE110/C	160	110	400	100	380
KDNE 150-200/224/A/BAQE/1/15/4 T MCE150/C	160	110	400	100	380	1800	1200	730	670	280	426	200	150	1504	467	1644	472

KDNE - 2 POLES

STANDARDISED CENTRIFUGAL ELECTRIC PUMPS WITH INVERTER

SELECTION TABLE - KDNE 32

MODEL	Q=m ³ /h	0	6	12	18	24	30	36	42	48
	Q=l/min	0	100	200	300	400	500	600	700	800
KDNE 32-125.1/110	H (m)	15.5	15.2	13.9	11.5					
KDNE 32-125.1/130		22.3	22.2	21.3	19					
KDNE 32-125.1/140		26.5	26.4	25.6	23.4	20.1				
KDNE 32-125/125		20.9		20.1	18.9	16.9	13.5			
KDNE 32-125/130		22.9		22	21	19.1	16.2			
KDNE 32-125/142		27.8		27	26.1	24.5	21.7	18		
KDNE 32-160.1/137		21.5	21.2	19.3						
KDNE 32-160.1/145		24.7	24.5	22.3	16.5					
KDNE 32-160.1/153		28.3	28	26	20.5					
KDNE 32-160.1/177		39.5	39.3	38.2	34.5	26				
KDNE 32-160/145		27		25.8	23.9	21.2	16.9			
KDNE 32-160/161		34		33	31.7	29.1	25.5			
KDNE 32-160/177		41.8		41.5	40.5	38.4	35.3	31.4		
KDNE 32-200.1/170		34.3	34.2	31.9	23.5					
KDNE 32-200.1/190		45.3	44.7	41.5	35.5					
KDNE 32-200.1/207		55.3	55	51.8	46.4	37				
KDNE 32-200/180		39		38.5	36.5	32.5	28			
KDNE 32-200/200		51		49	48	45	40.5	35		
KDNE 32-200/210		57		56	55	52.5	48.5	43	36	
KDNE 32-200/219		63		62	61	59	56.5	52.5	46.5	39.5

SELECTION TABLE - KDNE 40

MODEL	Q=m ³ /h	0	6	12	18	24	30	36	42	48	54	60	66	72
	Q=l/min	0	100	200	300	400	500	600	700	800	900	1000	1100	1200
KDNE 40-125/120	H (m)	18.5		18	17.5	17	16	15	13.5	11.8				
KDNE 40-125/142		26.8		26.6	26.4	26	25.3	24.4	23	21.4	19.4	17		
KDNE 40-160/145		27.5			27.4	27	25.7	24.2	22.1	19.5				
KDNE 40-160/161		34.5			34.5	34.4	33.7	32.3	30.5	28.5	25.8	22.5		
KDNE 40-160/177		42.6			42.5	42.4	42	41.5	40	38.5	35	33	30	
KDNE 40-200/180		38.8			38.5	38	37	35	32.5	29	25			
KDNE 40-200/200		48.7			48.4	48.2	47.5	46.5	44	41.5	38.5	34.5		
KDNE 40-200/219		60			59.8	59.7	59.4	59	57	55	52.5	49.5	46	40
KDNE 40-250/220		63.1			62.8	62.5	61	59	57	55	52	48		

KDNE - 2 POLES**STANDARDISED CENTRIFUGAL ELECTRIC PUMPS WITH INVERTER****SELECTION TABLE - KDNE 50**

MODEL	Q=m ³ /h	0	6	12	18	24	30	36	42	48	54	60	66	72	78	84	90	102	114	
	Q=l/min	0	100	200	300	400	500	600	700	800	900	1000	1100	1200	1300	1400	1500	1700	1900	
KDNE 50-125/125	H (m)	19.8					19.4	19	18.5	17.9	17.4	16.6	16	15.1	14	13	11.8			
KDNE 50-125/139		24.7					24.5	24.3	24	23.5	23	22.4	21.6	20.8	20	19.2	18	15.5		
KDNE 50-125/144		25.9					26.5	26.4	26.1	25.6	25.1	24.5	24	23.2	22.3	21.5	20.5	17.8	15	
KDNE 50-160/145		27.2					27	26.9	26.6	26.4	25.5	25	23.8	23	21.5	20.5	19			
KDNE 50-160/161		33.8					33.7	33.7	33.6	33.6	33.3	32.5	31.8	31	29.8	28.5	27.5			
KDNE 50-160/177		41.6					41.5	41.5	41.3	41.2	41	40.6	40.5	39.5	38.8	38	36.7	33.5		
KDNE 50-200/180		42.5					42	41.7	41.4	40.5	39.5	38	36	34	32	29				
KDNE 50-200/190		47.2					46.8	46.6	46	45.7	44.5	43.5	42	40	38	35.5	33			

SELECTION TABLE - KDNE 65

MODEL	Q=m ³ /h	0	48	54	60	66	72	78	84	90	102	114	120	150	180	210	240
	Q=l/min	0	800	900	1000	1100	1200	1300	1400	1500	1700	1900	2000	2500	3000	3500	4000
KDNE 65-125/120	H (m)	17.8	16	15.6	15.3	14.9	14.4	13.9	13.4	13	11.5	10.3	9.4				
KDNE 65-125/130		21	19.6	19.5	19.1	18.9	18.5	18	17.5	17	15.7	14.2	13.2				
KDNE 65-125/144		25.6	25.5	25.4	25.2	25	24.6	24.3	24	23.4	22.5	21.1	20.2	16			
KDNE 65-160/137		23.1	22.4	22	21.7	21.3	20.5	19.7	19	18	16						
KDNE 65-160/153		29.1	28.8	28.5	28.6	28.5	28	27.5	26.6	26	24	22	21				
KDNE 65-160/169		36.4	36.3	36.2	36.1	36	35.7	35.3	34.7	34	32.7	31	30				
KDNE 65-200/170		37.2	36.8	36.7	36.6	36.5	36	35	34	32.5	30	27	25				

SELECTION TABLE - KDNE 80

MODEL	Q=m ³ /h	0	90	102	114	120	150	180	210	240	270	300
	Q=l/min	0	1500	1700	1900	2000	2500	3000	3500	4000	4500	5000
KDNE 80-160/153	H (m)	29.3	28	27.3	26.5	26	23.5	20.7	16.5	14.5		

KDNE 32-125.1 - 2 POLES - STANDARDISED CENTRIFUGAL ELECTRIC PUMPS WITH INVERTER FOR CIRCULATION SYSTEMS



Pumped liquid temperature range: from -10 °C to +140 °C (MCE/C) - Maximum ambient temperature: +40 °C

= 2900 1/min

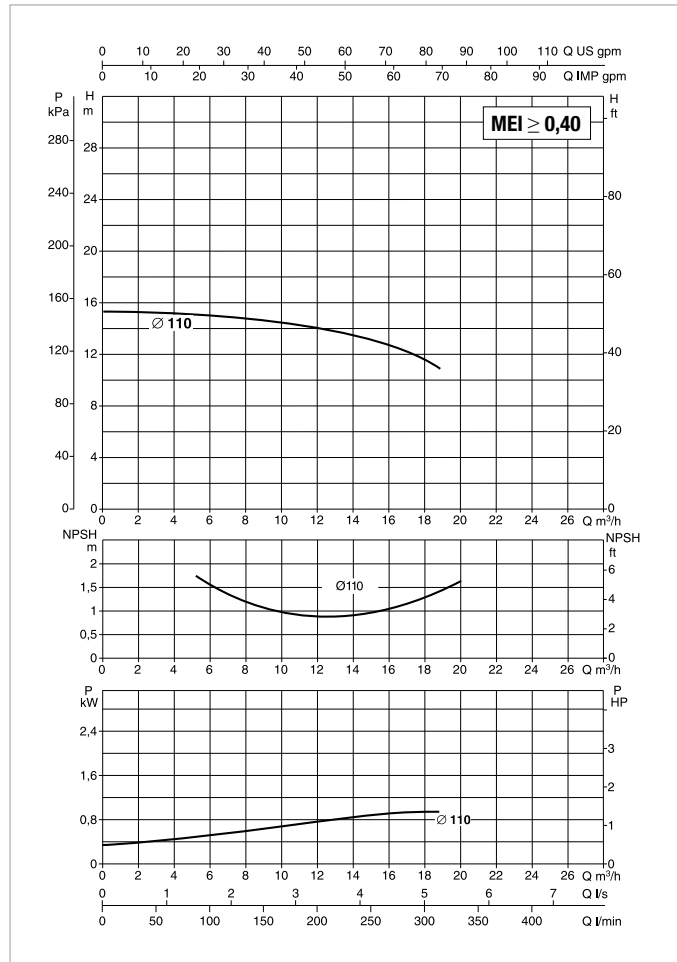
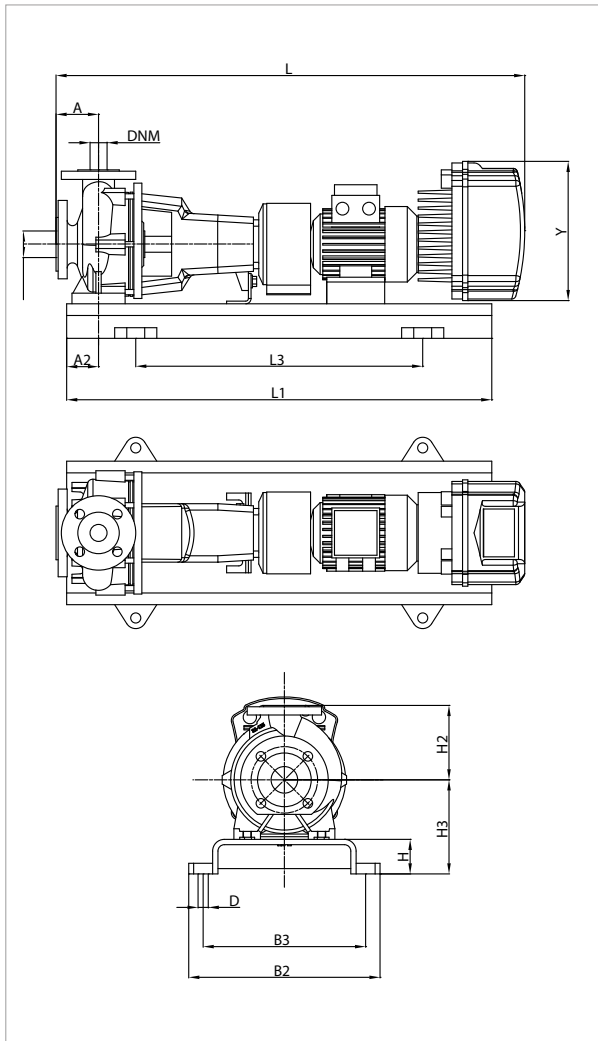

See hydraulic efficiency details on page 241.

The performance curves are based on kinematic viscosity values = 1 mm²/s and density equal to 1000 kg/m³. Curve tolerance according to ISO 9906.

MODEL	MCE MODEL	POWER INPUT 50 Hz	P2 NOMINAL		In A
			kW	HP	
KDNE 32-125.1/110/A/BAQE/1/1,5/2 M MCE15/C	MCE15/C	1 x 230 ~V	1,5	2	14,1
KDNE 32-125.1/110/A/BAQE/1/1,5/2 T MCE30/C	MCE30/C	3 x 400 ~V	1,5	2	4,2

MODEL	A	A2	H2	H	H3	L1	L3	B2	B3	D	Y	FLANGE DIMENSIONS (mm)		STANDARD COUPLING		SPACER COUPLING	
												DNA	DNM	L	WEIGHT kg	L	WEIGHT kg
												KDNE 32-125.1/110/A/BAQE/1/1,5/2 M MCE15/C	80	60	140	65	177
KDNE 32-125.1/110/A/BAQE/1/1,5/2 T MCE30/C	80	60	140	65	177	800	540	360	320	19	353	50	32	1056	99,6	1156	104,6

KDNE 32-125.1 - 2 POLES - STANDARDISED CENTRIFUGAL ELECTRIC PUMPS WITH INVERTER FOR CIRCULATION SYSTEMS



Pumped liquid temperature range: from -10 °C to +140 °C (MCE/C) - Maximum ambient temperature: +40 °C

= 2900 1/min

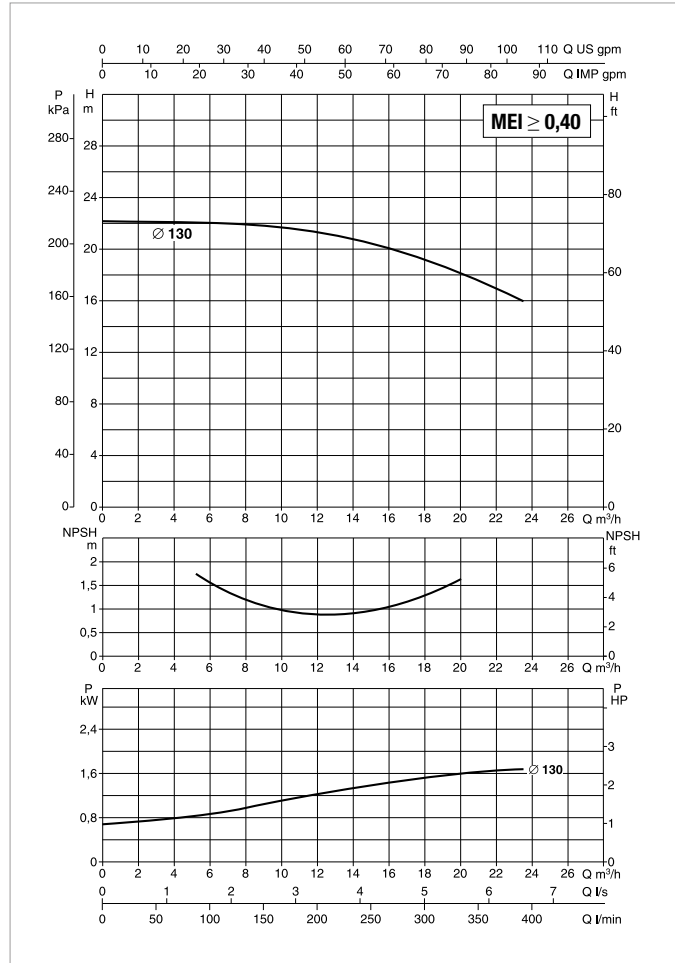
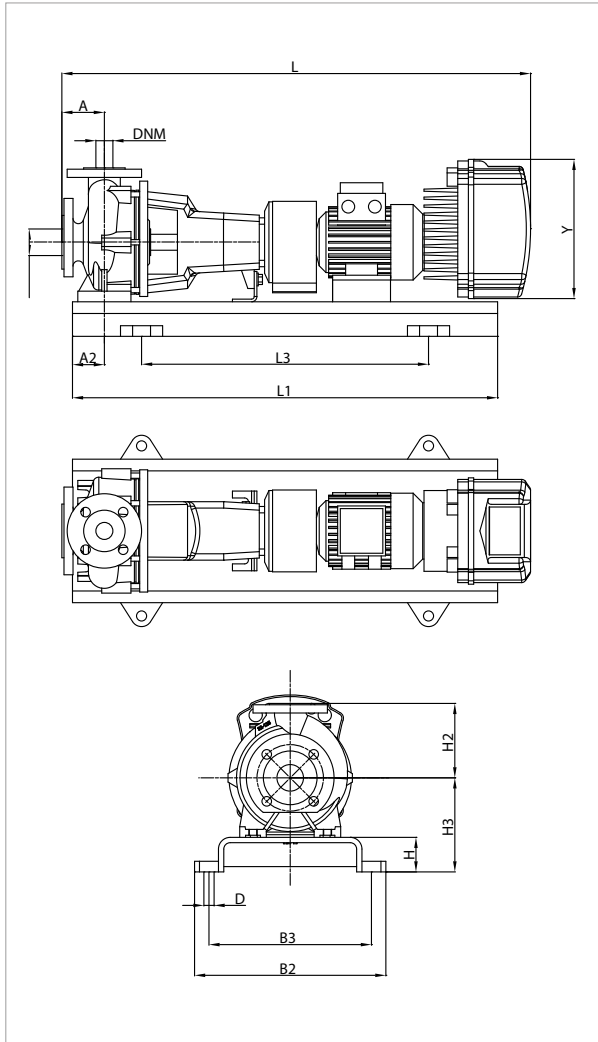

See hydraulic efficiency details on page 241.

The performance curves are based on kinematic viscosity values = 1 mm²/s and density equal to 1000 kg/m³. Curve tolerance according to ISO 9906.

MODEL	MCE MODEL	POWER INPUT 50 Hz	P2 NOMINAL		In A
			kW	HP	
KDNE 32-125.1/130/A/BAQE/1/2,2/2 M MCE22/C	MCE22/C	1 x 230 ~V	2,2	3	19,6
KDNE 32-125.1/130/A/BAQE/1/2,2/2 T MCE30/C	MCE30/C	3 x 400 ~V	2,2	3	6

MODEL	A	A2	H2	H	H3	L1	L3	B2	B3	D	Y	FLANGE DIMENSIONS (mm)		STANDARD COUPLING		SPACER COUPLING	
												DNA	DNM	L	WEIGHT kg	L	WEIGHT kg
												KDNE 32-125.1/130/A/BAQE/1/2,2/2 M MCE22/C	80	60	140	65	177
KDNE 32-125.1/130/A/BAQE/1/2,2/2 T MCE30/C	80	60	140	65	177	900	600	390	350	19	353	50	32	1056	106,6	1156	111,6

KDNE 32-125.1 - 2 POLES - STANDARDISED CENTRIFUGAL ELECTRIC PUMPS WITH INVERTER FOR PRESSURISATION SYSTEMS



Pumped liquid temperature range: from -10 °C to +80 °C (MCE/P) - Maximum ambient temperature: +40 °C

= 2900 1/min

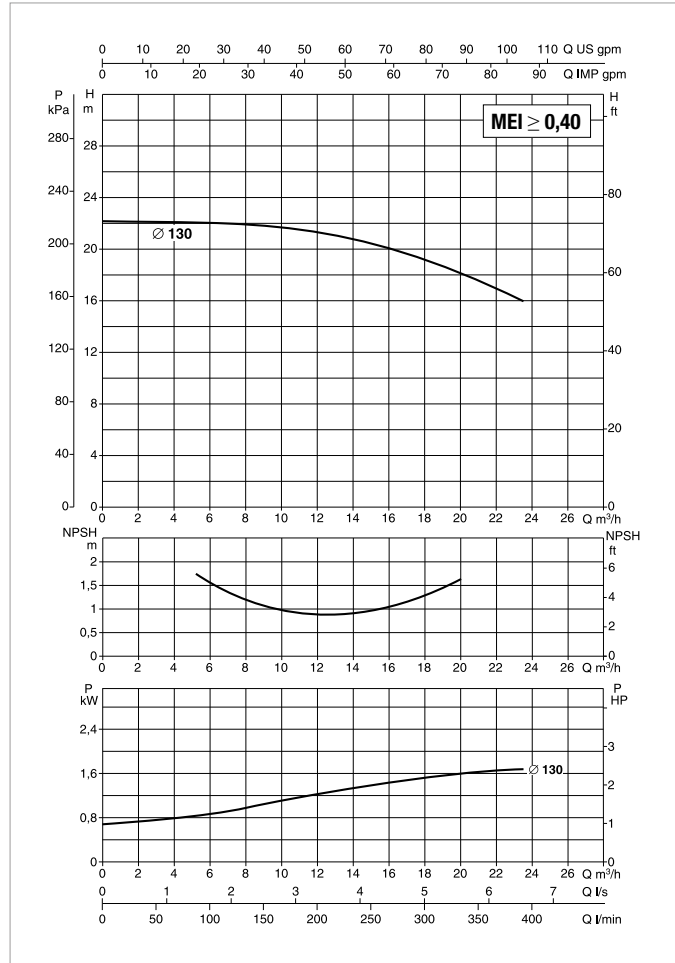
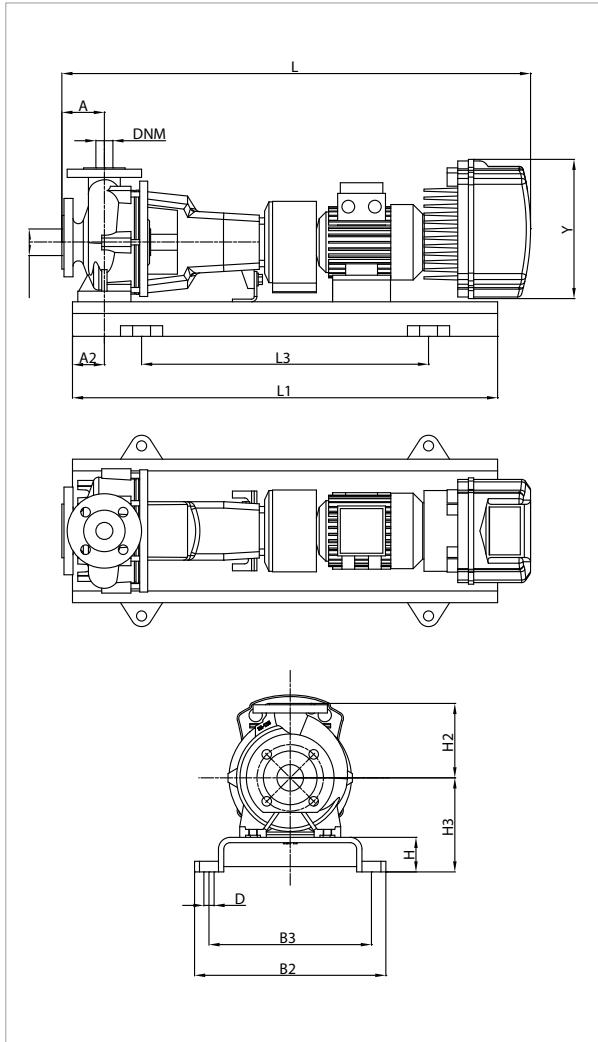

See hydraulic efficiency details on page 241.

The performance curves are based on kinematic viscosity values = 1 mm²/s and density equal to 1000 kg/m³. Curve tolerance according to ISO 9906.

MODEL	MCE MODEL	POWER INPUT 50 Hz	P2 NOMINAL		In A
			kW	HP	
KDNE 32-125.1/130/A/BAQE/1/2.2/2 M MCE22/P	MCE22/P	1 x 230 ~V	2,2	3	19,6

MODEL	A	A2	H2	H	H3	L1	L3	B2	B3	D	Y	FLANGE DIMENSIONS (mm)		STANDARD COUPLING		SPACER COUPLING	
												DNA	DNM	L	WEIGHT kg	L	WEIGHT kg
												KDNE 32-125.1/130/A/BAQE/1/2.2/2 M MCE22/P	80	60	140	65	177

KDNE 32-125.1 - 2 POLES - STANDARDISED CENTRIFUGAL ELECTRIC PUMPS WITH INVERTER FOR CIRCULATION OR PRESSURISATION SYSTEMS

MCE-C

MCE-P

Pumped liquid temperature range: from -10 °C to +140 °C (MCE/C) - from -10 °C to +80 °C (MCE/P) - Maximum ambient temperature: +40 °C = 2900 1/min

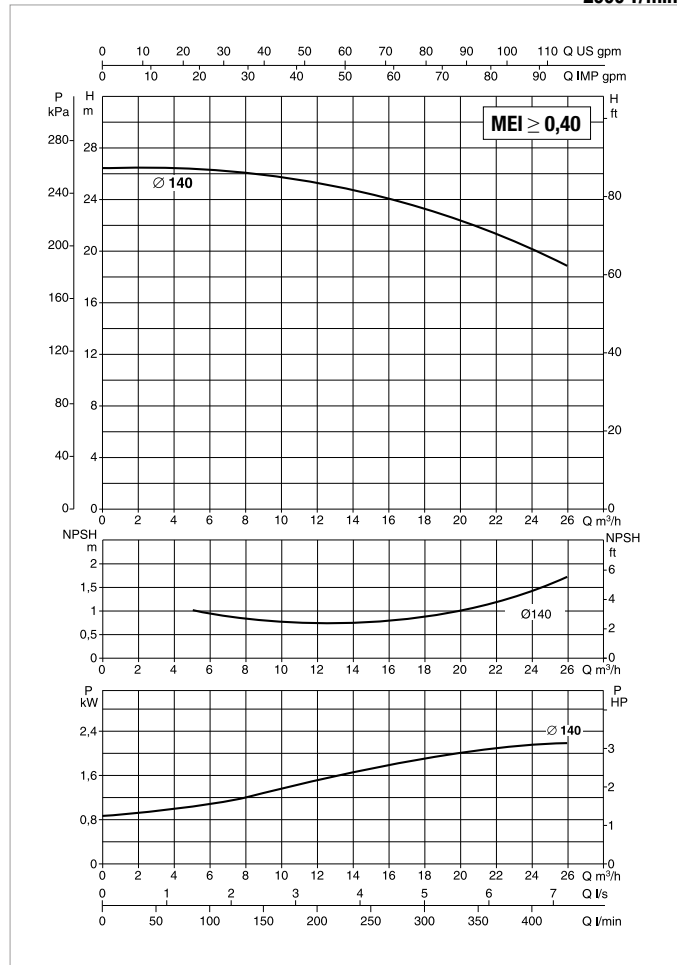
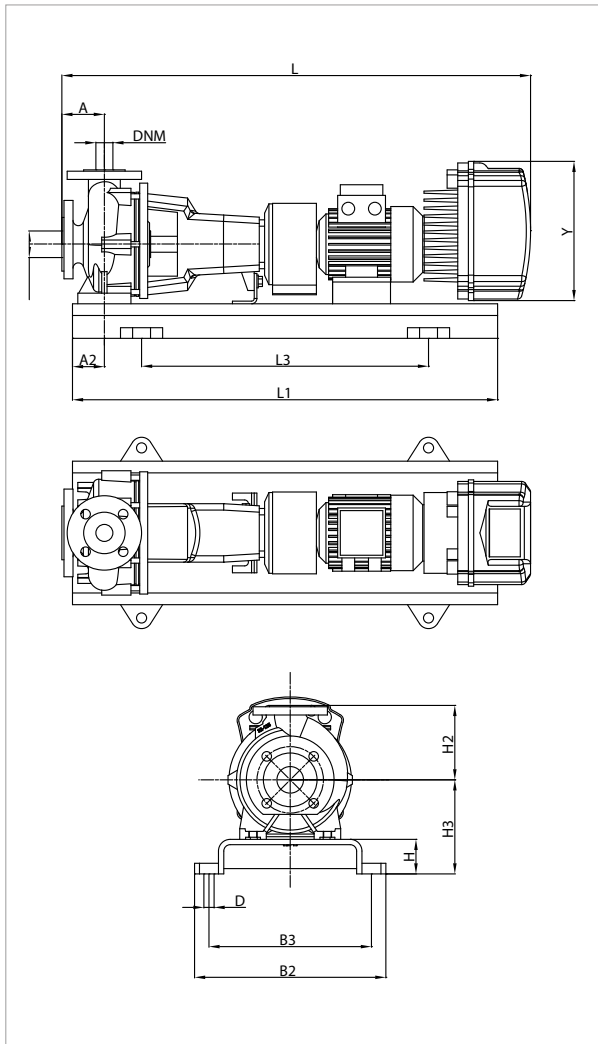

See hydraulic efficiency details on page 241.

The performance curves are based on kinematic viscosity values = 1 mm²/s and density equal to 1000 kg/m³. Curve tolerance according to ISO 9906.

MODEL	MCE MODEL	POWER INPUT 50 Hz	P2 NOMINAL		In A
			kW	HP	
KDNE 32-125.1/140/A/BAQE/1/3/2 T MCE30/C-P	MCE30/C - MCE30/P	3 x 400 ~V	3	4	7,4

MODEL	A	A2	H2	H	H3	L1	L3	B2	B3	D	Y	FLANGE DIMENSIONS (mm)		STANDARD COUPLING		SPACER COUPLING	
												DNA	DNM	L	WEIGHT kg	L	WEIGHT kg
												KDNE 32-125.1/140/A/BAQE/1/3/2 T MCE30/C-P	80	60	140	65	177

KDNE 32-125 - 2 POLES - STANDARDISED CENTRIFUGAL ELECTRIC PUMPS WITH INVERTER FOR CIRCULATION SYSTEMS



Pumped liquid temperature range: from -10 °C to +140 °C (MCE/C) - Maximum ambient temperature: +40 °C

= 2900 1/min

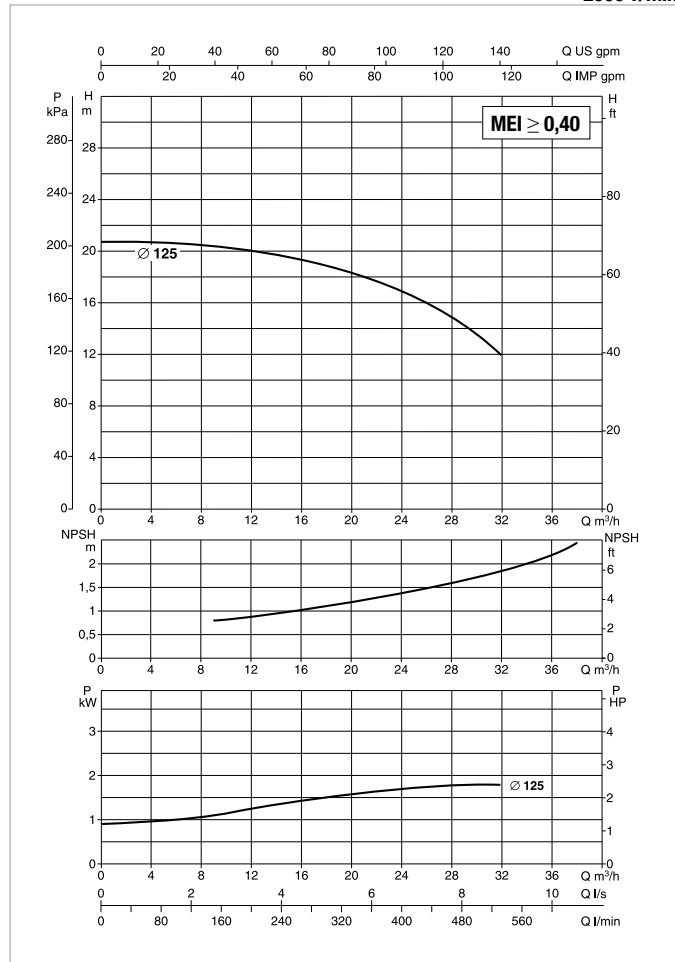
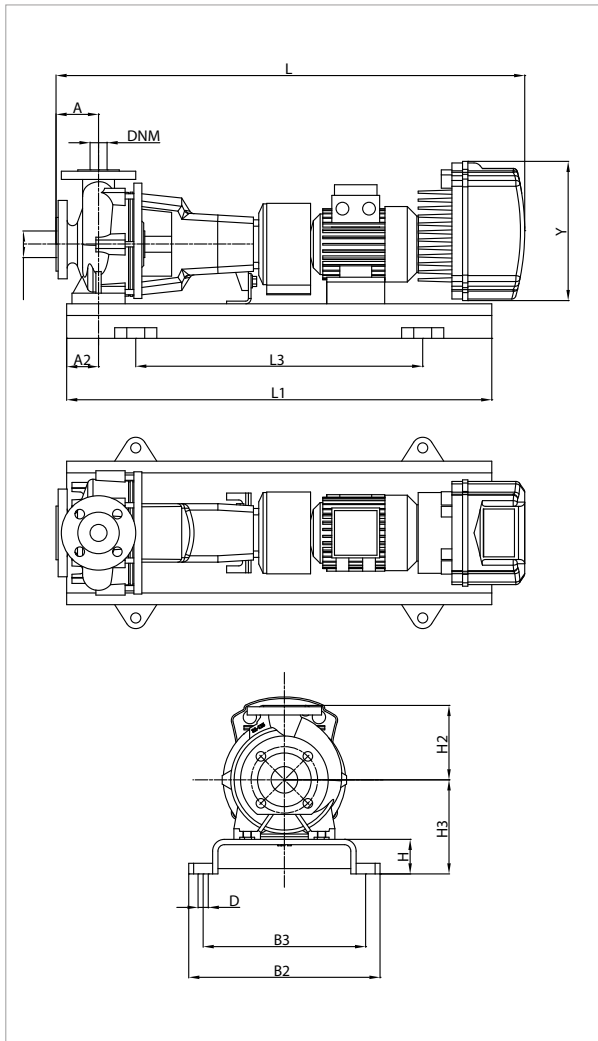

See hydraulic efficiency details on page 241.

The performance curves are based on kinematic viscosity values = 1 mm²/s and density equal to 1000 kg/m³. Curve tolerance according to ISO 9906.

MODEL	MCE MODEL	POWER INPUT 50 Hz	P2 NOMINAL		In A
			kW	HP	
KDNE 32-125/125/A/BAQE/1/2,2/2 M MCE22/C	MCE22/C	1 x 230 ~V	2,2	3	19,6
KDNE 32-125/125/A/BAQE/1/2,2/2 T MCE30/C	MCE30/C	3 x 400 ~V	2,2	3	6

MODEL	A	A2	H2	H	H3	L1	L3	B2	B3	D	Y	FLANGE DIMENSIONS (mm)		STANDARD COUPLING		SPACER COUPLING	
												DNA	DNM	L	WEIGHT kg	L	WEIGHT kg
												KDNE 32-125/125/A/BAQE/1/2,2/2 M MCE22/C	80	60	140	65	177
KDNE 32-125/125/A/BAQE/1/2,2/2 T MCE30/C	80	60	140	65	177	900	600	390	350	19	353	50	32	1056	99,6	1156	104,6

KDNE 32-125 - 2 POLES - STANDARDISED CENTRIFUGAL ELECTRIC PUMPS WITH INVERTER FOR PRESSURISATION SYSTEMS



Pumped liquid temperature range: from -10 °C to +80 °C (MCE/P) - Maximum ambient temperature: +40 °C

= 2900 1/min

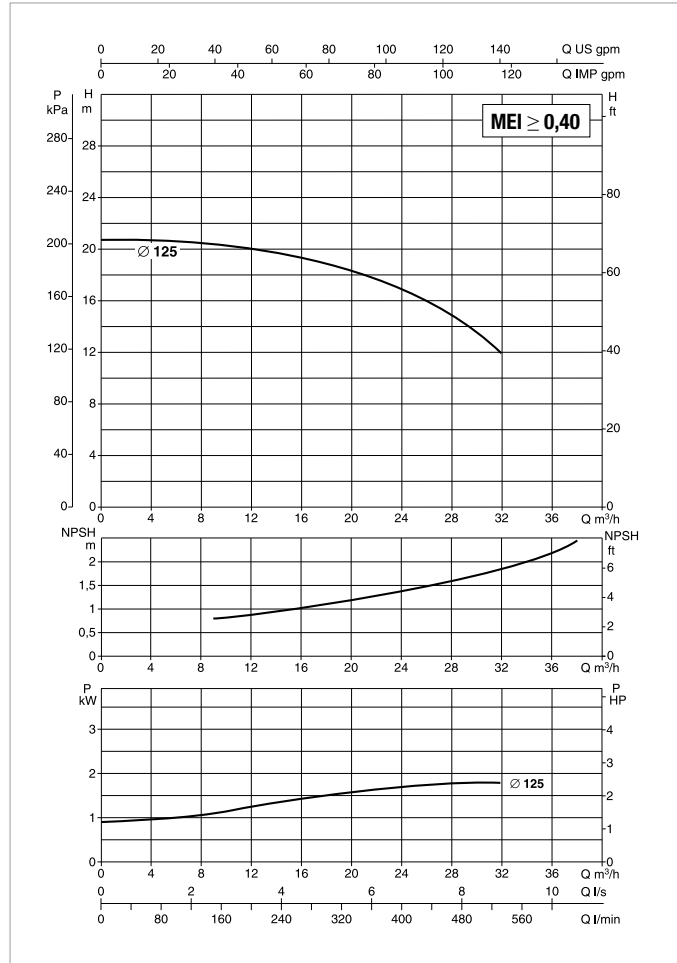
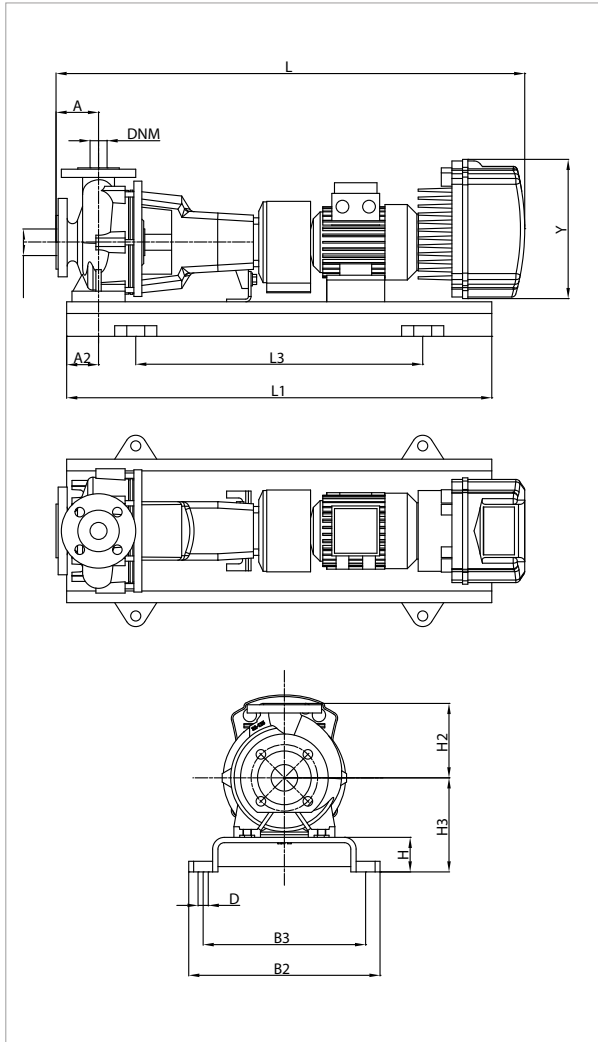

See hydraulic efficiency details on page 241.

The performance curves are based on kinematic viscosity values = 1 mm²/s and density equal to 1000 kg/m³. Curve tolerance according to ISO 9906.

MODEL	MCE MODEL	POWER INPUT 50 Hz	P2 NOMINAL		In A
			kW	HP	
KDNE 32-125/125/A/BAQE/1/2.2/2 M MCE22/P	MCE22/P	1 x 230 ~V	2,2	3	19,6

MODEL	A	A2	H2	H	H3	L1	L3	B2	B3	D	Y	FLANGE DIMENSIONS (mm)		STANDARD COUPLING		SPACER COUPLING	
												DNA	DNM	L	WEIGHT kg	L	WEIGHT kg
												KDNE 32-125/125/A/BAQE/1/2.2/2 M MCE22/P	80	60	140	65	177

KDNE 32-125 - 2 POLES - STANDARDISED CENTRIFUGAL ELECTRIC PUMPS WITH INVERTER FOR CIRCULATION OR PRESSURISATION SYSTEMS

MCE-C

MCE-P

Pumped liquid temperature range: from -10 °C to +140 °C (MCE/C) - from -10 °C to +80 °C (MCE/P) - Maximum ambient temperature: +40 °C
= 2900 1/min

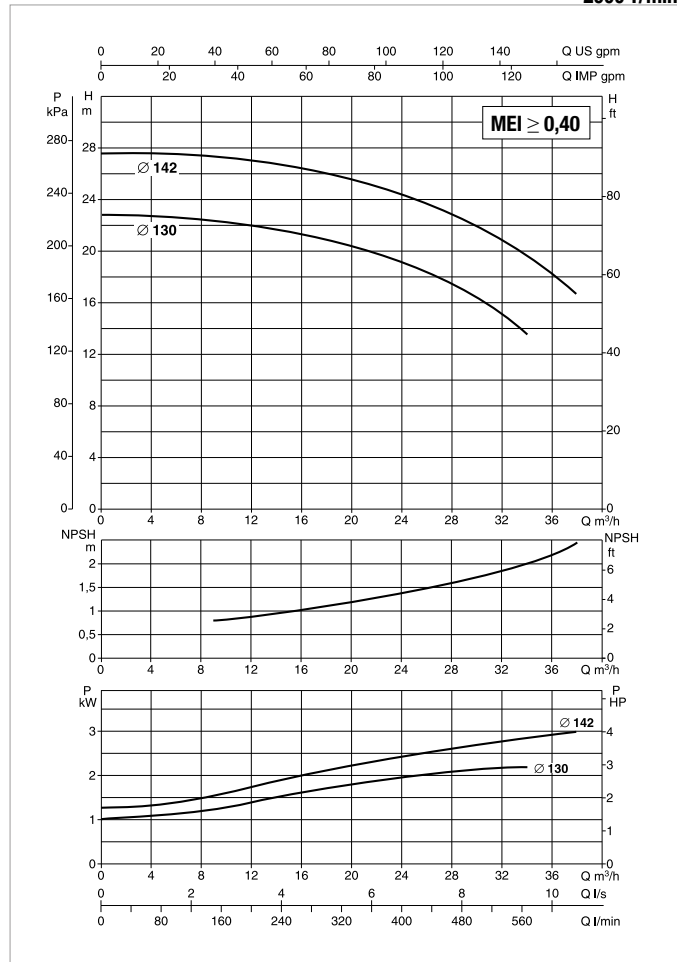
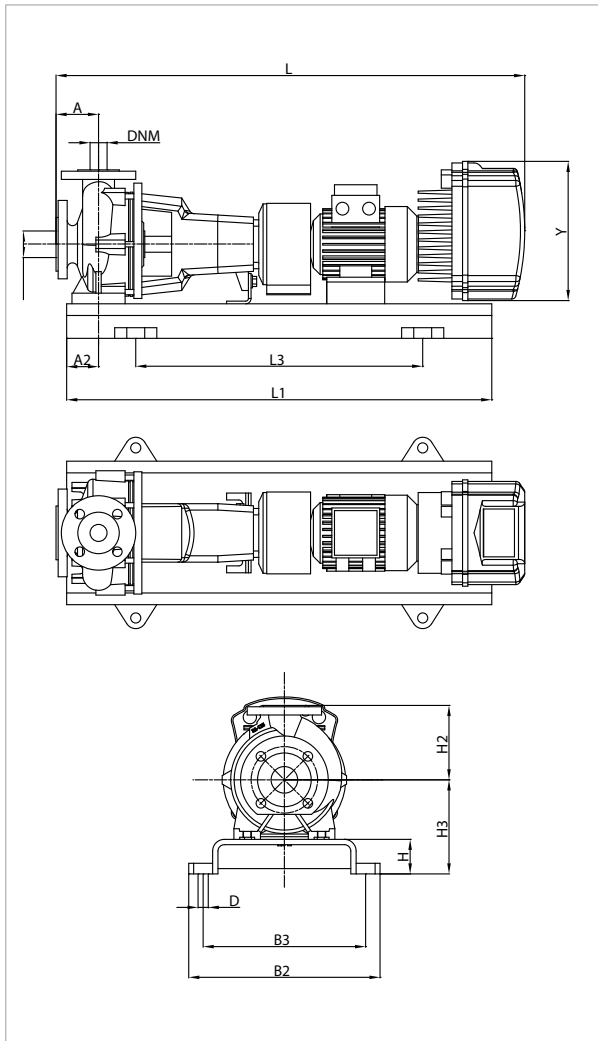

See hydraulic efficiency details on page 241.

The performance curves are based on kinematic viscosity values = mm²/s and density equal to 1000 kg/m³. Curve tolerance according to ISO 9906.

MODEL	MCE MODEL	POWER INPUT 50 Hz	P2 NOMINAL		In A
			kW	HP	
KDNE 32-125/130/A/BAQE/1/3/2 T MCE30/C-P	MCE30/C - MCE30/P	3 x 400 ~V	3	4	7,4
KDNE 32-125/142/A/BAQE/1/4/2 T MCE55/C-P	MCE55/C - MCE55/P	3 x 400 ~V	4	5,5	10,1

MODEL	A	A2	H2	H	H3	L1	L3	B2	B3	D	Y	FLANGE DIMENSIONS (mm)		STANDARD COUPLING		SPACER COUPLING	
												DNA	DNM	L	WEIGHT kg	L	WEIGHT kg
												KDNE 32-125/130/A/BAQE/1/3/2 T MCE30/C-P	80	60	140	65	177
KDNE 32-125/142/A/BAQE/1/4/2 T MCE55/C-P	80	60	140	65	177	900	600	390	350	19	353	50	32	1046	126	1146	131

KDNE 32-160.1 - 2 POLES - STANDARDISED CENTRIFUGAL ELECTRIC PUMPS WITH INVERTER FOR CIRCULATION SYSTEMS



Pumped liquid temperature range: from -10 °C to +140 °C (MCE/C) - Maximum ambient temperature: +40 °C

= 2900 1/min

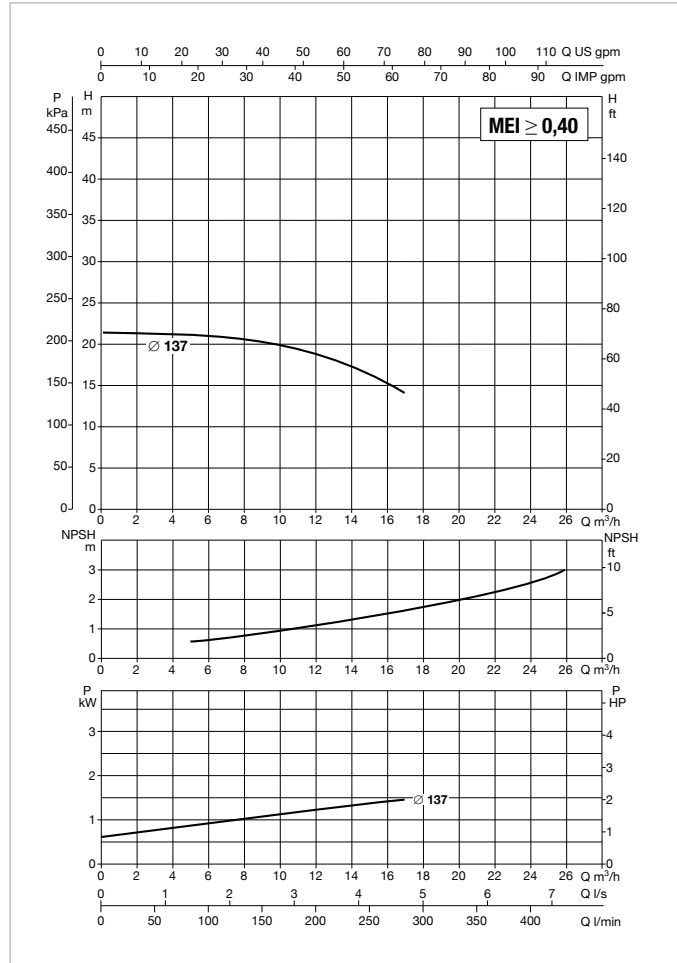
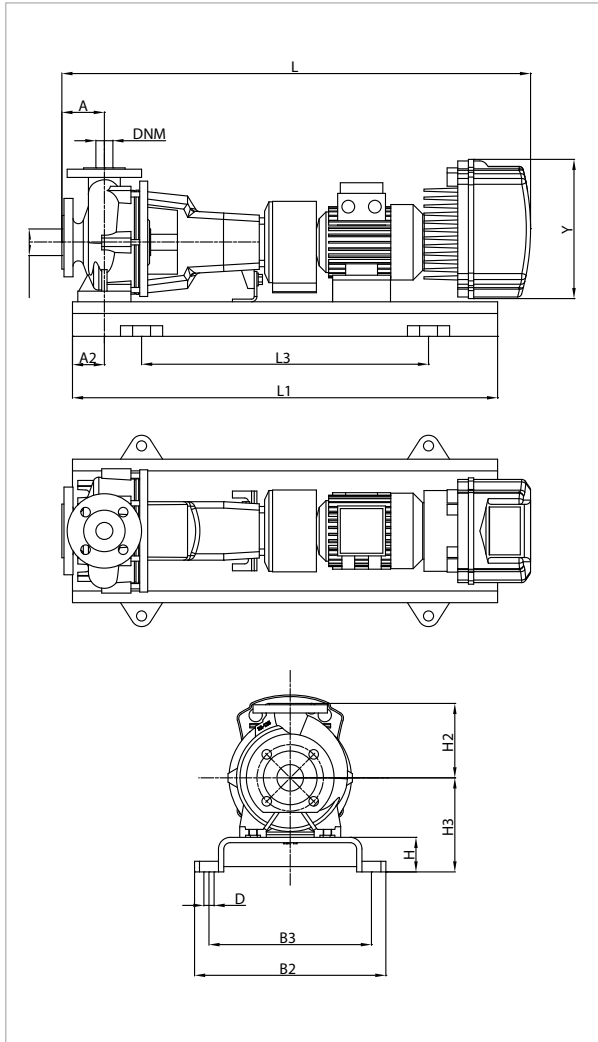

See hydraulic efficiency details on page 241.

The performance curves are based on kinematic viscosity values = 1 mm²/s and density equal to 1000 kg/m³. Curve tolerance according to ISO 9906.

MODEL	MCE MODEL	POWER INPUT 50 Hz	P2 NOMINAL		In A
			kW	HP	
KDNE 32-160.1/137/A/BAQE/1/1,5/2 M MCE15/C	MCE15/C	1 x 230 ~V	1,5	2	14,1
KDNE 32-160.1/137/A/BAQE/1/1,5/2 T MCE30/C	MCE30/C	3 x 400 ~V	1,5	2	4,2

MODEL	A	A2	H2	H	H3	L1	L3	B2	B3	D	Y	FLANGE DIMENSIONS (mm)		STANDARD COUPLING		SPACER COUPLING	
												DNA	DNM	L	WEIGHT kg	L	WEIGHT kg
												KDNE 32-160.1/137/A/BAQE/1/1,5/2 M MCE15/C	80	60	160	65	197
KDNE 32-160.1/137/A/BAQE/1/1,5/2 T MCE30/C	80	60	160	65	197	800	540	360	320	19	353	50	32	1056	100,6	1156	105,6

KDNE 32-160.1 - 2 POLES - STANDARDISED CENTRIFUGAL ELECTRIC PUMPS WITH INVERTER FOR PRESSURISATION SYSTEMS



Pumped liquid temperature range: from -10 °C to +80 °C (MCE/P) - Maximum ambient temperature: +40 °C

= 2900 1/min

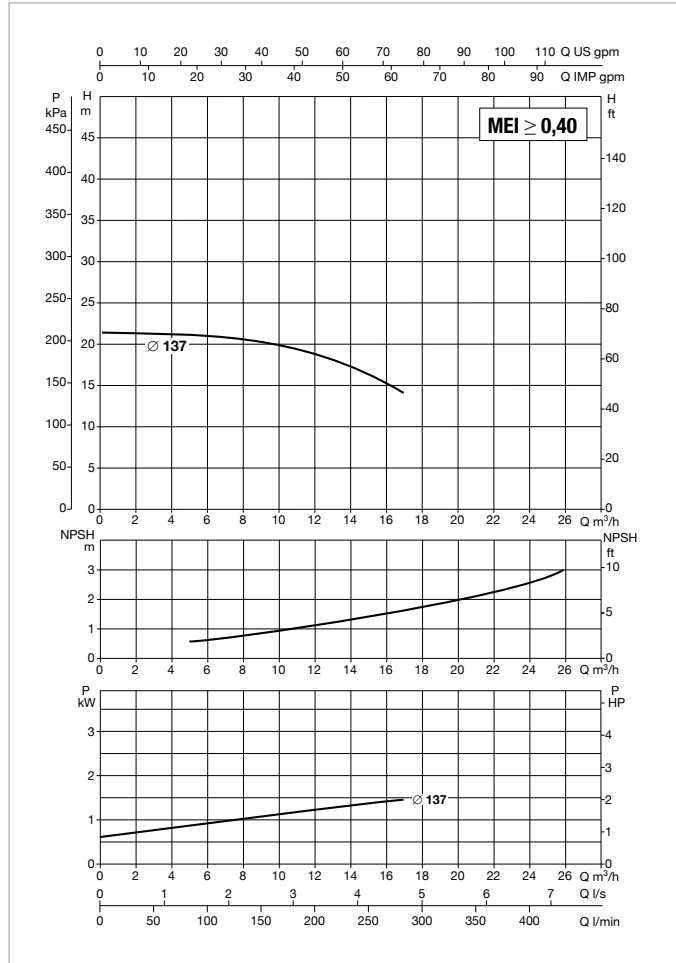
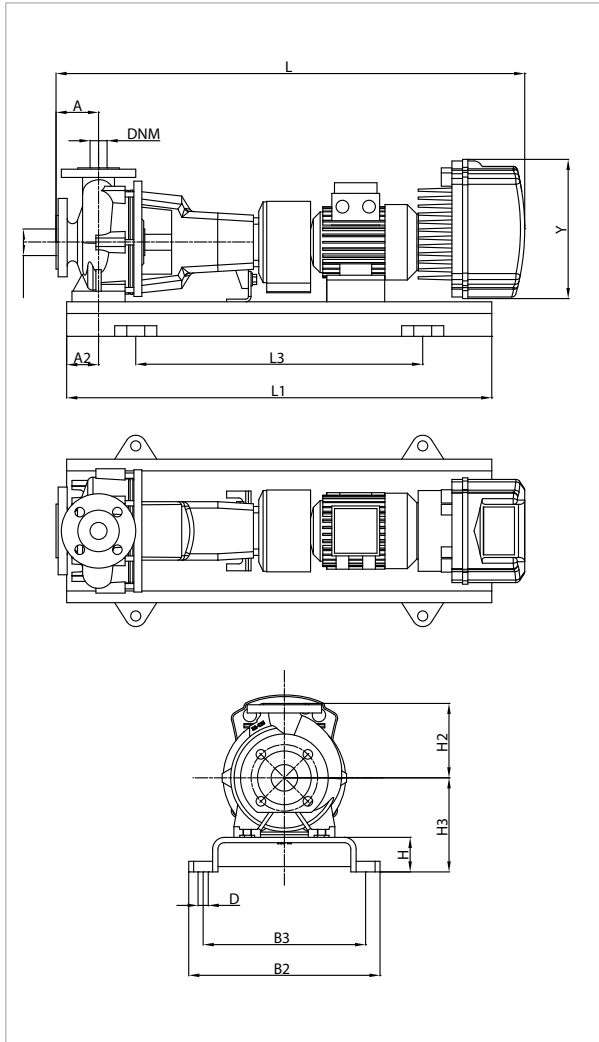

See hydraulic efficiency details on page 241.

The performance curves are based on kinematic viscosity values = 1 mm²/s and density equal to 1000 kg/m³. Curve tolerance according to ISO 9906.

MODEL	MCE MODEL	POWER INPUT 50 Hz	P2 NOMINAL		In A
			kW	HP	
KDNE 32-160.1/137/A/BAQE/1/1,5/2 MCE22/P	MCE22/P	1 x 230 ~V	1,5	2	14,1

MODEL	A	A2	H2	H	H3	L1	L3	B2	B3	D	Y	FLANGE DIMENSIONS (mm)		STANDARD COUPLING		SPACER COUPLING	
												DNA	DNM	L	WEIGHT kg	L	WEIGHT kg
												KDNE 32-160.1/137/A/BAQE/1/1,5/2 MCE22/P	80	60	160	65	197

KDNE 32-160.1 - 2 POLES - STANDARDISED CENTRIFUGAL ELECTRIC PUMPS WITH INVERTER FOR CIRCULATION SYSTEMS



Pumped liquid temperature range: from -10 °C to +140 °C (MCE/C) - Maximum ambient temperature: +40 °C

= 2900 1/min

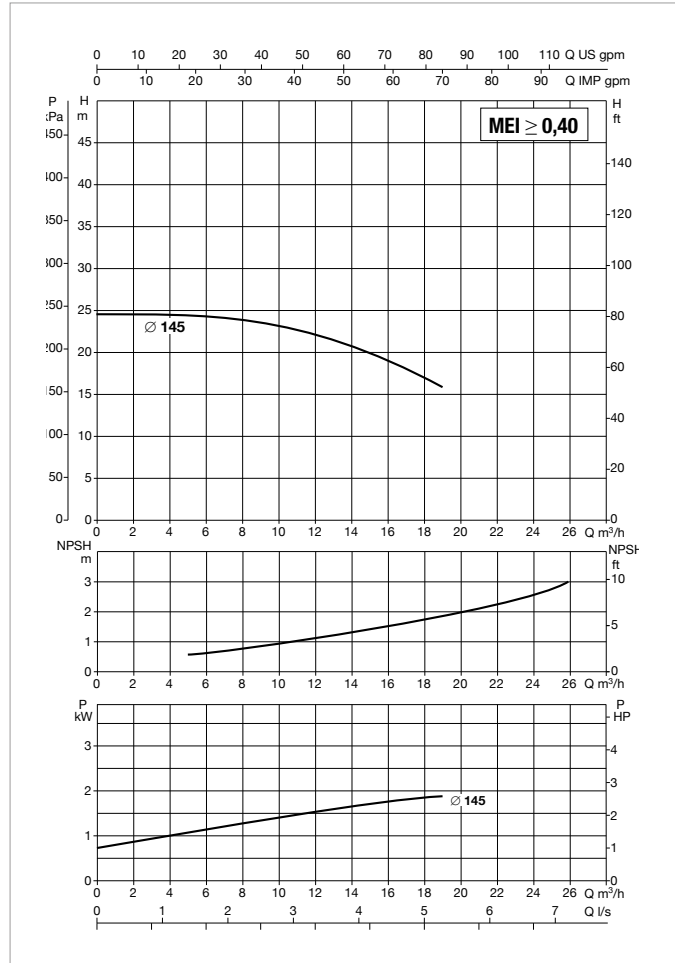
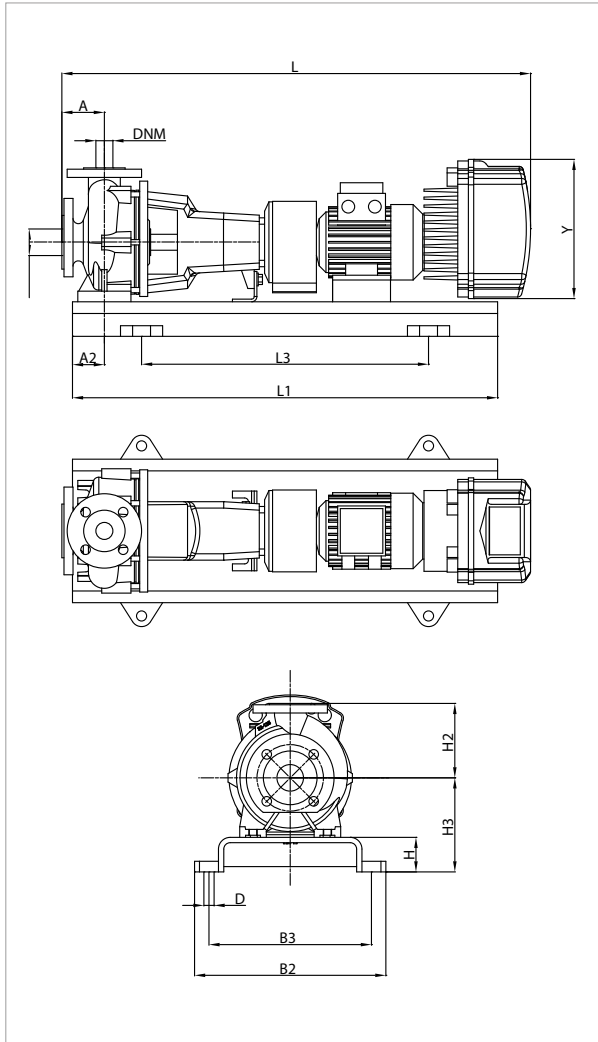

See hydraulic efficiency details on page 241.

The performance curves are based on kinematic viscosity values = 1 mm²/s and density equal to 1000 kg/m³. Curve tolerance according to ISO 9906.

MODEL	MCE MODEL	POWER INPUT 50 Hz	P2 NOMINAL		In A
			kW	HP	
KDNE 32-160.1/145/A/BAQE/1/2,2/2 M MCE22/C	MCE22/C	1 x 230 ~V	2,2	3	19,6
KDNE 32-160.1/145/A/BAQE/1/2,2/2 T MCE30/C	MCE30/C	3 x 400 ~V	2,2	3	6

MODEL	A	A2	H2	H	H3	L1	L3	B2	B3	D	Y	FLANGE DIMENSIONS (mm)		STANDARD COUPLING		SPACER COUPLING	
												DNA	DNM	L	WEIGHT kg	L	WEIGHT kg
												KDNE 32-160.1/145/A/BAQE/1/2,2/2 M MCE22/C	80	60	160	65	197
KDNE 32-160.1/145/A/BAQE/1/2,2/2 T MCE30/C	80	60	160	65	197	900	600	390	350	19	353	50	32	1056	108,6	1156	113,6

KDNE 32-160.1 - 2 POLES - STANDARDISED CENTRIFUGAL ELECTRIC PUMPS WITH INVERTER FOR PRESSURISATION SYSTEMS



Pumped liquid temperature range: from -10 °C to +80 °C (MCE/P) - Maximum ambient temperature: +40 °C

= 2900 1/min

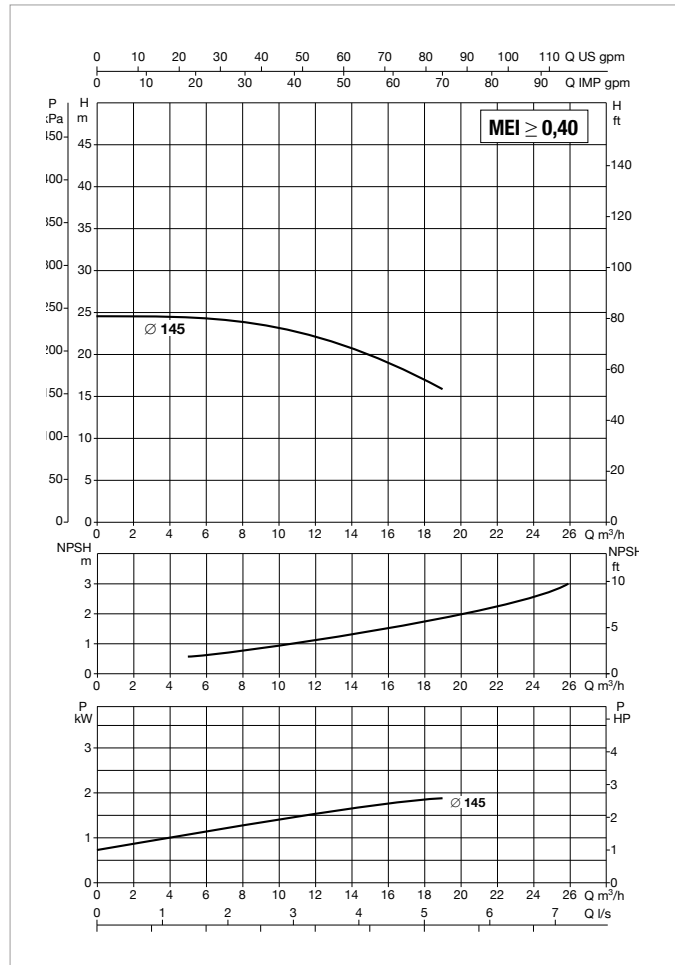
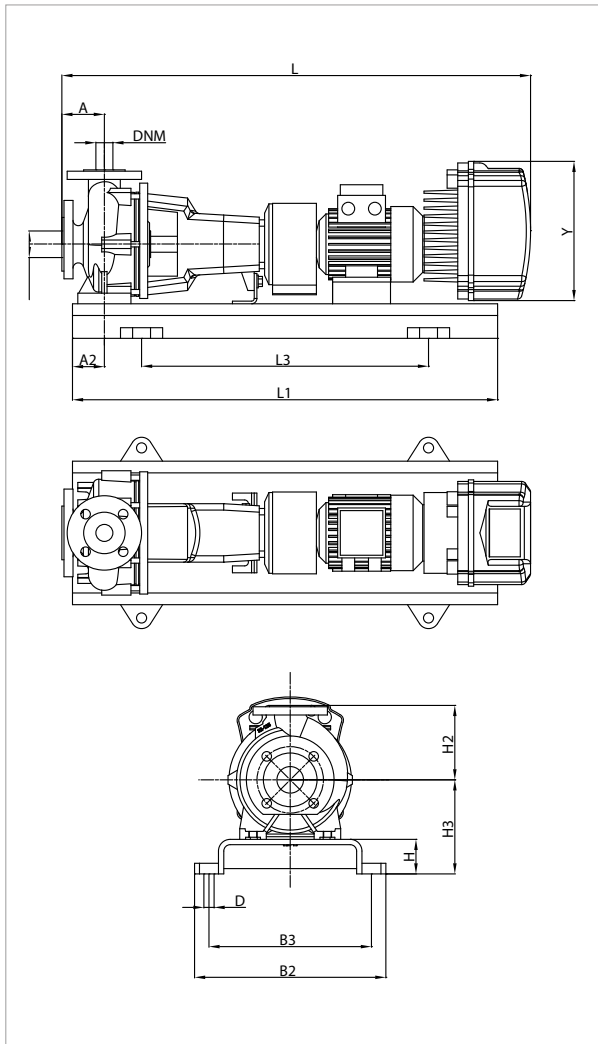

See hydraulic efficiency details on page 241.

The performance curves are based on kinematic viscosity values = 1 mm²/s and density equal to 1000 kg/m³. Curve tolerance according to ISO 9906.

MODEL	MCE MODEL	POWER INPUT 50 Hz	P2 NOMINAL		In A
			kW	HP	
KDNE 32-160.1/145/A/BAQE/1/2.2/2 M MCE22/P	MCE22/P	1 x 230 ~V	2,2	3	19,6

MODEL	A	A2	H2	H	H3	L1	L3	B2	B3	D	Y	FLANGE DIMENSIONS (mm)		STANDARD COUPLING		SPACER COUPLING	
												DNA	DNM	L	WEIGHT kg	L	WEIGHT kg
												KDNE 32-160.1/145/A/BAQE/1/2.2/2 M MCE22/P	80	60	160	65	197

KDNE 32-160.1 - 2 POLES - STANDARDISED CENTRIFUGAL ELECTRIC PUMPS WITH INVERTER FOR CIRCULATION OR PRESSURISATION SYSTEMS



Pumped liquid temperature range: from -10 °C to +140 °C (MCE/C) - from -10 °C to +80 °C (MCE/P) - Maximum ambient temperature: +40 °C
= 2900 1/min

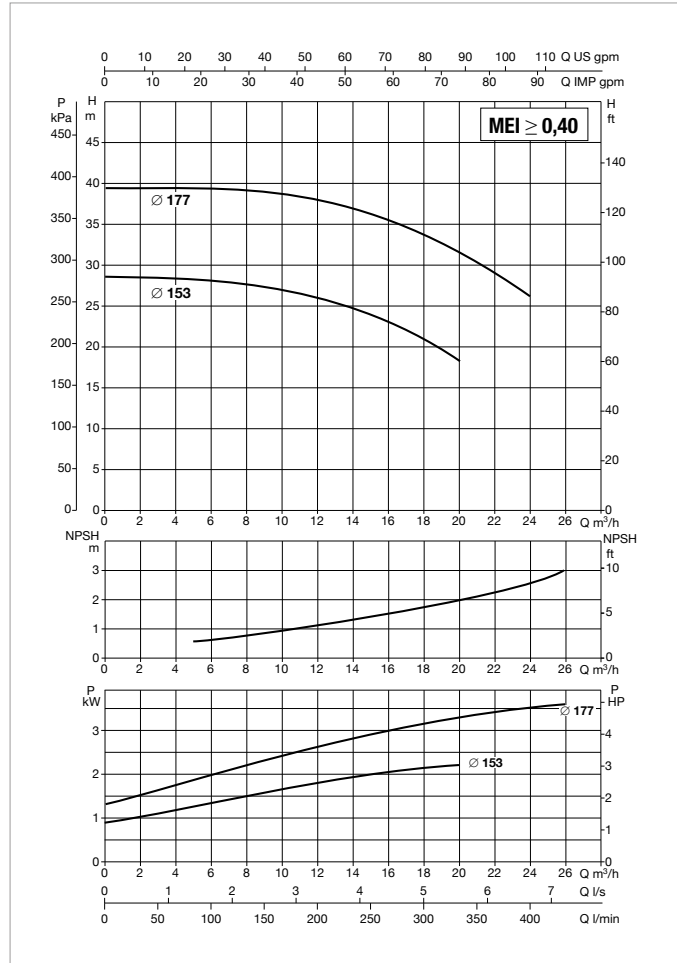
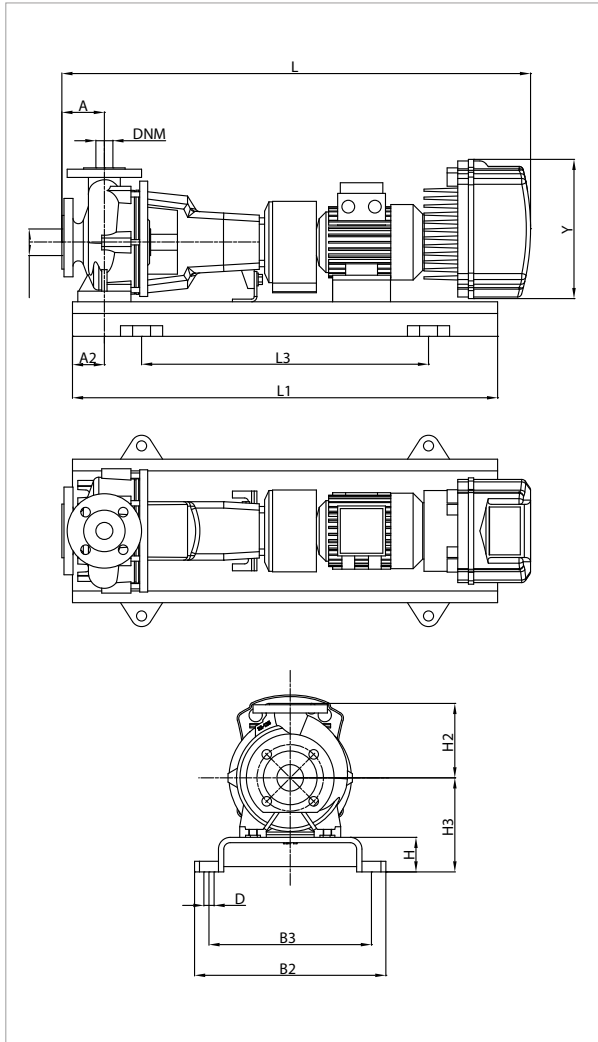

See hydraulic efficiency details on page 241.

The performance curves are based on kinematic viscosity values = 1 mm²/s and density equal to 1000 kg/m³. Curve tolerance according to ISO 9906.

MODEL	MCE MODEL	POWER INPUT 50 Hz	P2 NOMINAL		In A
			kW	HP	
KDNE 32-160.1/153/A/BAQE/1/3/2 T MCE30/C-P	MCE30/C - MCE30/P	3 x 400 ~V	3	4	7,4
KDNE 32-160.1/177/A/BAQE/1/5,5/2 T MCE55/C-P	MCE55/C - MCE55/P	3 x 400 ~V	5,5	7,5	13,1

MODEL	A	A2	H2	H	H3	L1	L3	B2	B3	D	Y	FLANGE DIMENSIONS (mm)		STANDARD COUPLING		SPACER COUPLING	
												DNA	DNM	L	WEIGHT kg	L	WEIGHT kg
												KDNE 32-160.1/153/A/BAQE/1/3/2 T MCE30/C-P	80	60	160	65	197
KDNE 32-160.1/177/A/BAQE/1/5,5/2 T MCE55/C-P	80	60	160	80	212	1000	660	450	400	24	353	50	32	1159	145	1259	150

KDNE 32-160 - 2 POLES - STANDARDISED CENTRIFUGAL ELECTRIC PUMPS WITH INVERTER FOR CIRCULATION OR PRESSURISATION SYSTEMS

MCE-C

MCE-P

Pumped liquid temperature range: from -10 °C to +140 °C (MCE/C) - from -10 °C to +80 °C (MCE/P) - Maximum ambient temperature: +40 °C
= 2900 1/min

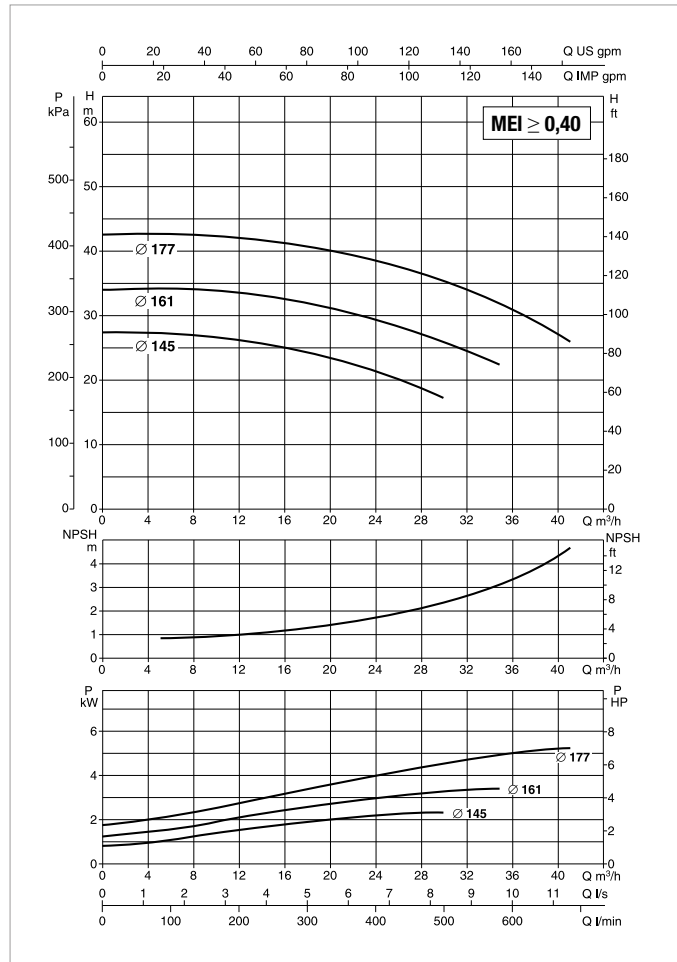
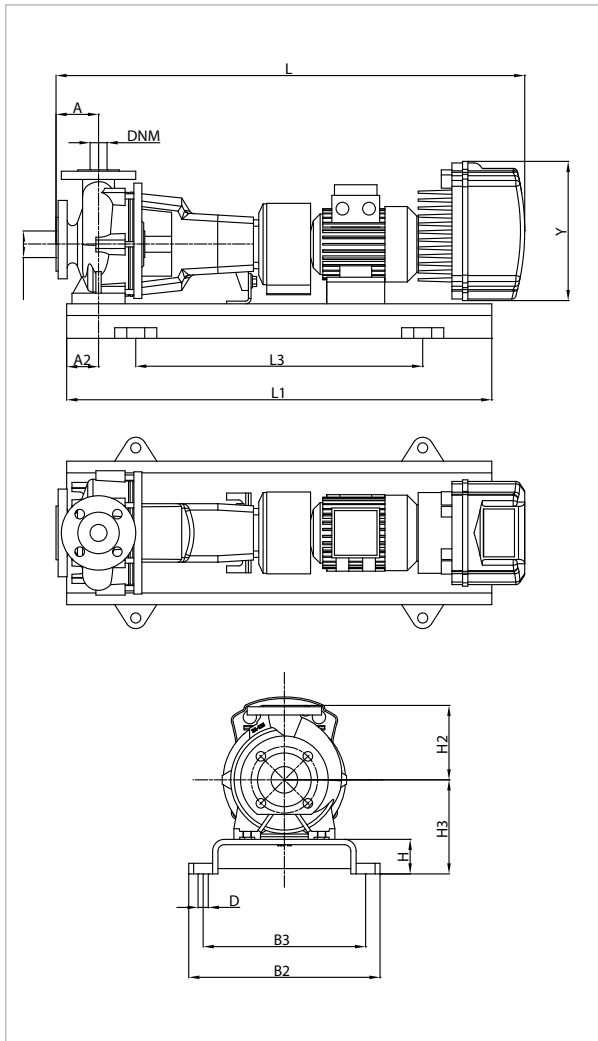

See hydraulic efficiency details on page 241.

The performance curves are based on kinematic viscosity values = 1 mm²/s and density equal to 1000 kg/m³. Curve tolerance according to ISO 9906.

MODEL	MCE MODEL	POWER INPUT 50 Hz	P2 NOMINAL		In A
			kW	HP	
KDNE 32-160/145/A/BAQE/1/3/2 T MCE30/C-P	MCE30/C - MCE30/P	3 x 400 ~V	3	4	7,4
KDNE 32-160/161/A/BAQE/1/5,5/2 T MCE55/C-P	MCE55/C - MCE55/P	3 x 400 ~V	5,5	7,5	13,1
KDNE 32-160/177/A/BAQE/1/7,5/2 T MCE110/C-P	MCE110/C - MCE110/P	3 x 400 ~V	7,5	10	17,6

MODEL	A	A2	H2	H	H3	L1	L3	B2	B3	D	Y	FLANGE DIMENSIONS (mm)		STANDARD COUPLING		SPACER COUPLING	
												DNA	DNM	L	WEIGHT kg	L	WEIGHT kg
KDNE 32-160/145/A/BAQE/1/3/2 T MCE30/C-P	80	60	160	65	197	900	600	390	350	19	353	50	32	1026	111	1126	116
KDNE 32-160/161/A/BAQE/1/5,5/2 T MCE55/C-P	80	60	160	80	212	1000	660	450	400	24	353	50	32	1159	145	1259	150
KDNE 32-160/177/A/BAQE/1/7,5/2 T MCE110/C-P	80	60	160	80	212	1000	660	450	400	24	426	50	32	1209	152	1309	157

KDNE 32-200.1 - 2 POLES - STANDARDISED CENTRIFUGAL ELECTRIC PUMPS WITH INVERTER FOR CIRCULATION OR PRESSURISATION SYSTEMS



Pumped liquid temperature range: from -10 °C to +140 °C (MCE/C) - from -10 °C to +80 °C (MCE/P) - Maximum ambient temperature: +40 °C
= 2900 1/min

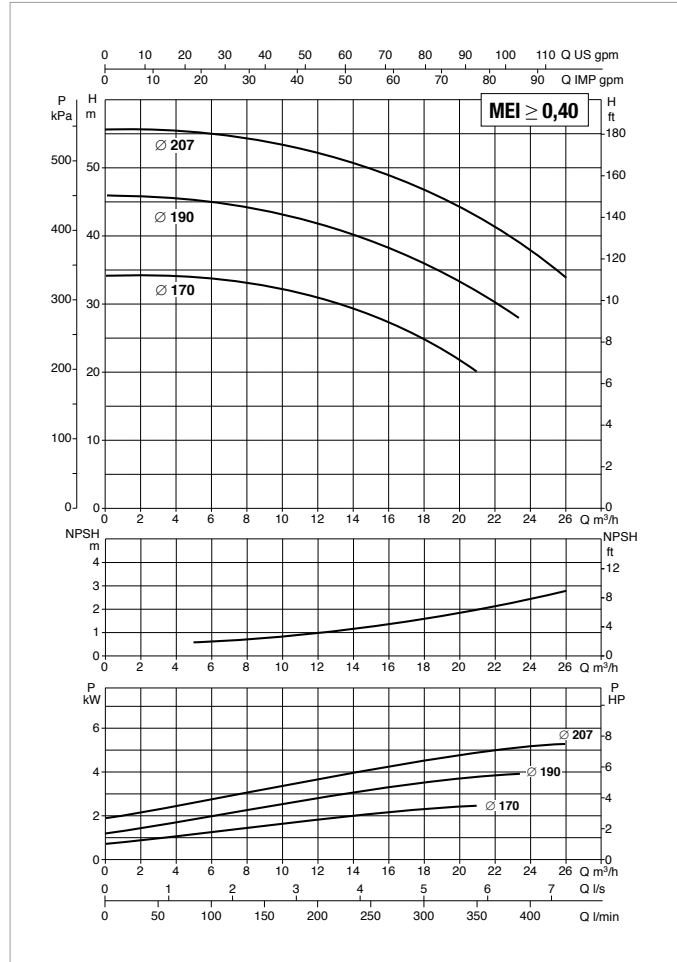
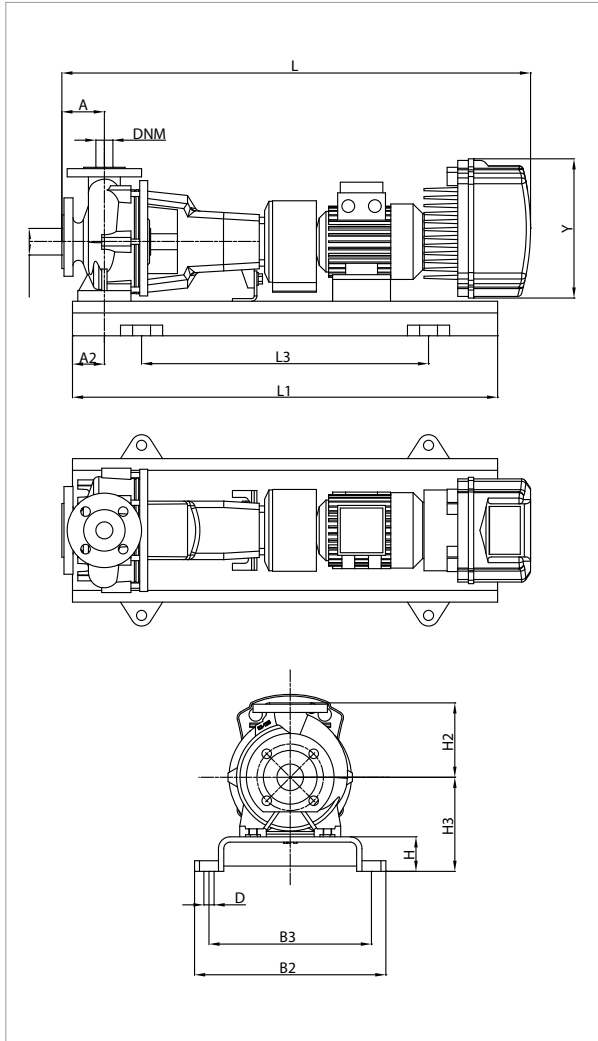

See hydraulic efficiency details on page 241.

The performance curves are based on kinematic viscosity values = 1 mm²/s and density equal to 1000 kg/m³. Curve tolerance according to ISO 9906.

MODEL	MCE MODEL	POWER INPUT 50 Hz	P2 NOMINAL		In A
			kW	HP	
KDNE 32-200.1/170/A/BAQE/1/3/2 T MCE30/C-P	MCE30/C - MCE30/P	3 x 400 ~V	3	4	7,4
KDNE 32-200.1/190/A/BAQE/1/5,5/2 T MCE55/C-P	MCE55/C - MCE55/P	3 x 400 ~V	5,5	7,5	13,1
KDNE 32-200.1/207/A/BAQE/1/7,5/2 T MCE110/C-P	MCE110/C - MCE110/P	3 x 400 ~V	7,5	10	17,6

MODEL	A	A2	H2	H	H3	L1	L3	B2	B3	D	Y	FLANGE DIMENSIONS (mm)		STANDARD COUPLING		SPACER COUPLING	
												DNA	DNM	L	WEIGHT kg	L	WEIGHT kg
KDNE 32-200.1/170/A/BAQE/1/3/2 T MCE30/C-P	80	60	180	65	225	900	600	390	350	19	353	50	32	1026	149	1126	154
KDNE 32-200.1/190/A/BAQE/1/5,5/2 T MCE55/C-P	80	60	180	80	240	1000	660	450	400	24	353	50	32	1159	152	1259	157
KDNE 32-200.1/207/A/BAQE/1/7,5/2 T MCE110/C-P	80	60	180	80	240	1000	660	450	400	24	426	50	32	1209	179	1309	184

KDNE 32-200 - 2 POLES - STANDARDISED CENTRIFUGAL ELECTRIC PUMPS WITH INVERTER FOR CIRCULATION OR PRESSURISATION SYSTEMS

MCE-C

MCE-P

Pumped liquid temperature range: from -10 °C to +140 °C (MCE/C) - from -10 °C to +80 °C (MCE/P) - Maximum ambient temperature: +40 °C
= 2900 1/min

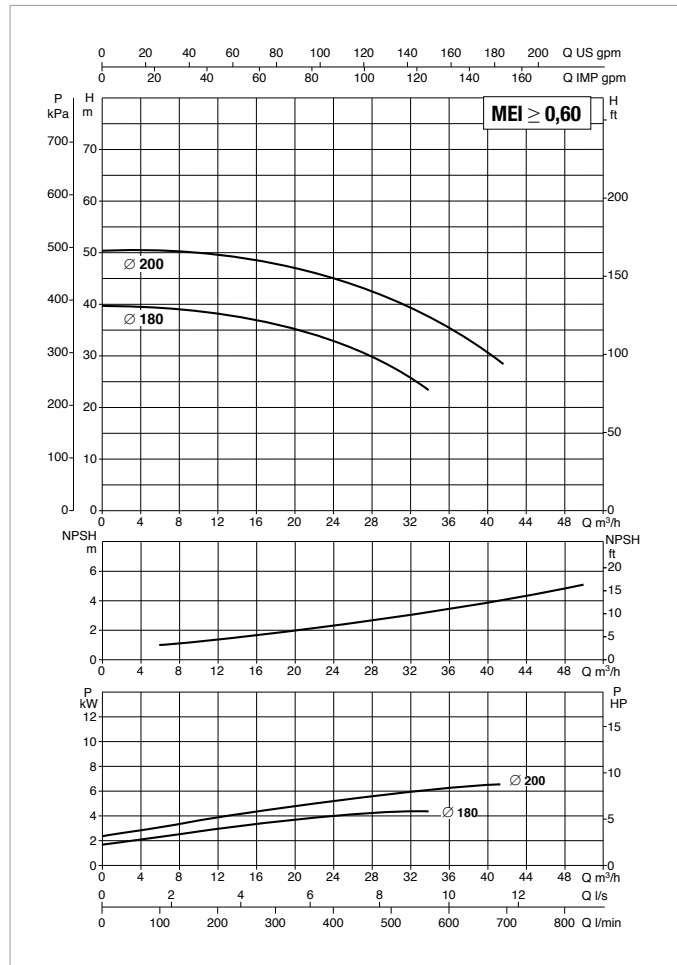
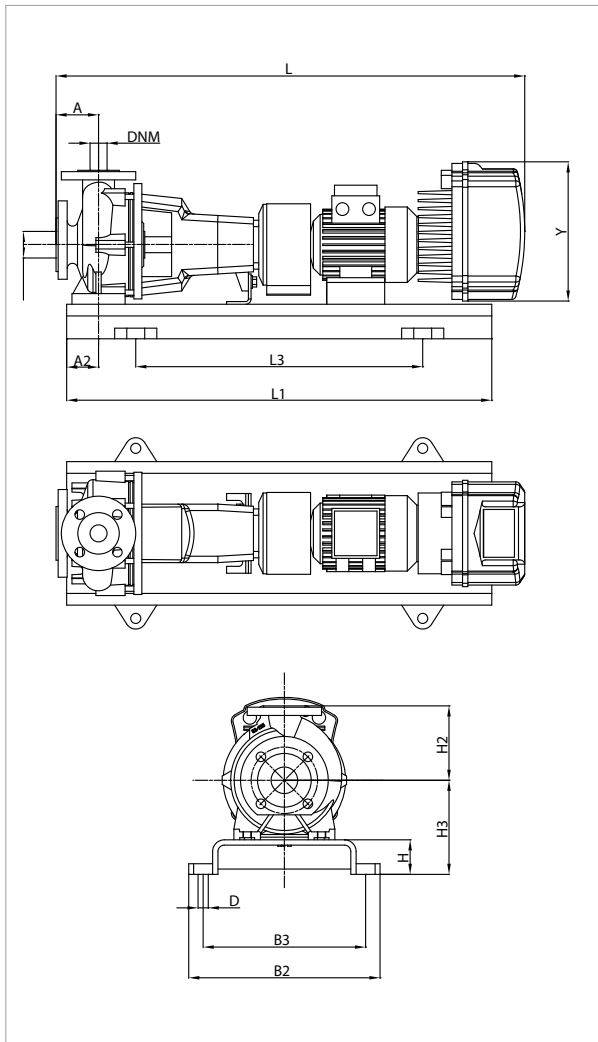

See hydraulic efficiency details on page 241.

The performance curves are based on kinematic viscosity values = 1 mm²/s and density equal to 1000 kg/m³. Curve tolerance according to ISO 9906.

MODEL	MCE MODEL	POWER INPUT 50 Hz	P2 NOMINAL		In A
			kW	HP	
KDNE 32-200/180/A/BAQE/1/5,5/2 T MCE55/C-P	MCE55/C - MCE55/P	3 x 400 ~V	5,5	7,5	13,1
KDNE 32-200/200/A/BAQE/1/7,5/2 T MCE110/C-P	MCE110/C - MCE110/P	3 x 400 ~V	7,5	10	17,6

MODEL	A	A2	H2	H	H3	L1	L3	B2	B3	D	Y	FLANGE DIMENSIONS (mm)		STANDARD COUPLING		SPACER COUPLING	
												DNA	DNM	L	WEIGHT kg	L	WEIGHT kg
												KDNE 32-200/180/A/BAQE/1/5,5/2 T MCE55/C-P	80	60	180	80	240
KDNE 32-200/200/A/BAQE/1/7,5/2 T MCE110/C-P	80	60	180	80	240	1000	660	450	400	24	426	50	32	1209	190	1309	195

KDNE 32-200 - 2 POLES - STANDARDISED CENTRIFUGAL ELECTRIC PUMPS WITH INVERTER FOR CIRCULATION SYSTEMS



Pumped liquid temperature range: from -10 °C to +140 °C (MCE/C) - Maximum ambient temperature: +40 °C

= 2900 1/min

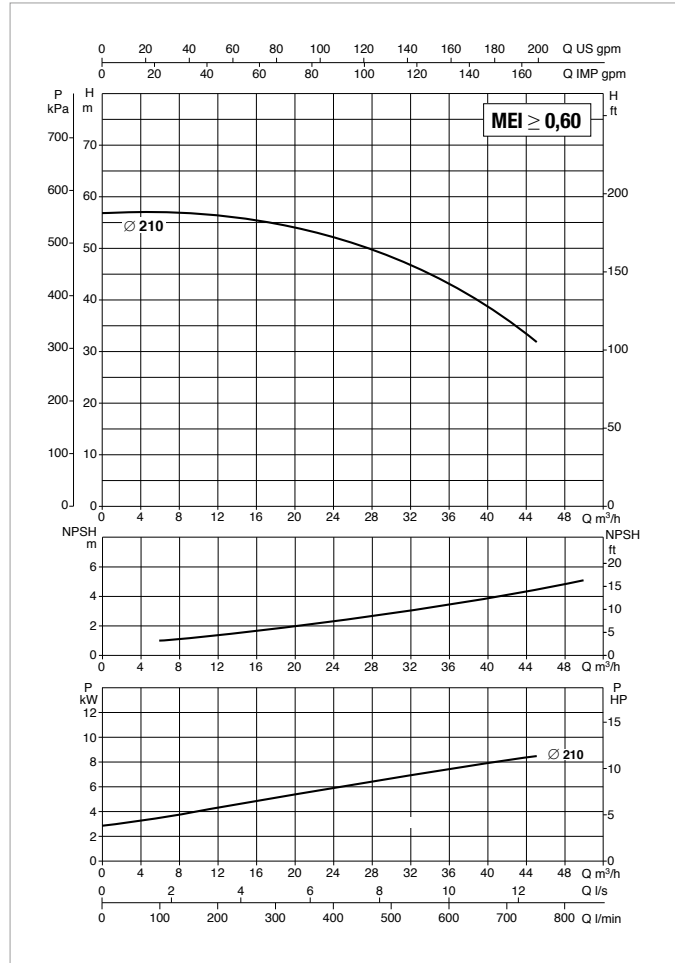
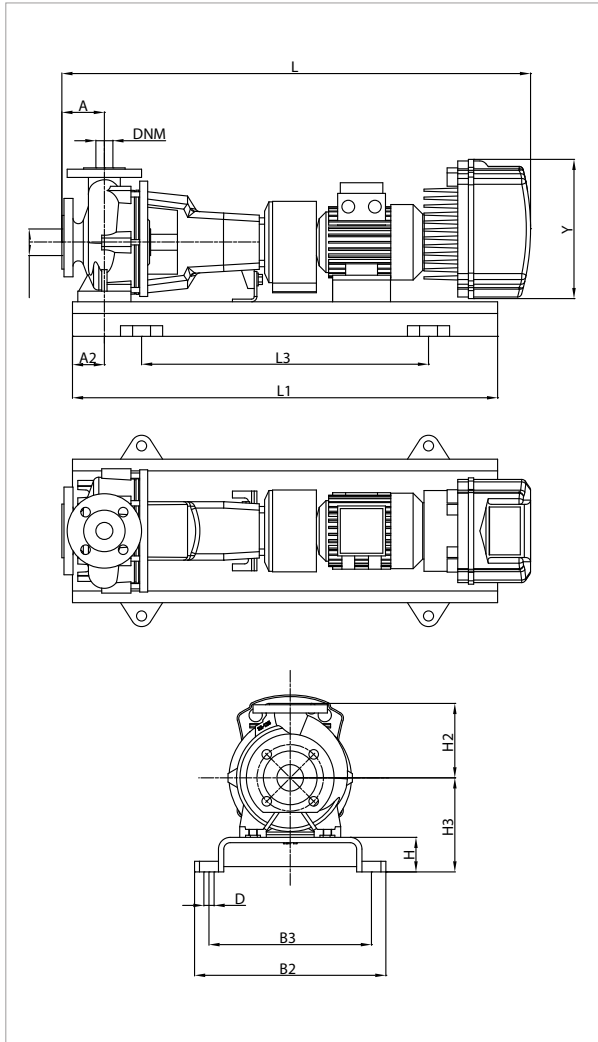

See hydraulic efficiency details on page 241.

The performance curves are based on kinematic viscosity values = 1 mm²/s and density equal to 1000 kg/m³. Curve tolerance according to ISO 9906.

MODEL	MCE MODEL	POWER INPUT 50 Hz	P2 NOMINAL		In A
			kW	HP	
KDNE 32-200/210/A/BAQE/1/11/2 T MCE110/C	MCE110/C	3 x 400 ~V	11	15	25,5

MODEL	A	A2	H2	H	H3	L1	L3	B2	B3	D	Y	FLANGE DIMENSIONS (mm)		STANDARD COUPLING		SPACER COUPLING	
												DNA	DNM	L	WEIGHT kg	L	WEIGHT kg
												KDNE 32-200/210/A/BAQE/1/11/2 T MCE110/C	80	60	180	80	240

KDNE 32-200 - 2 POLES - STANDARDISED CENTRIFUGAL ELECTRIC PUMPS WITH INVERTER FOR PRESSURISATION SYSTEMS



Pumped liquid temperature range: from -10 °C to +80 °C (MCE/P) - Maximum ambient temperature: +40 °C

= 2900 1/min

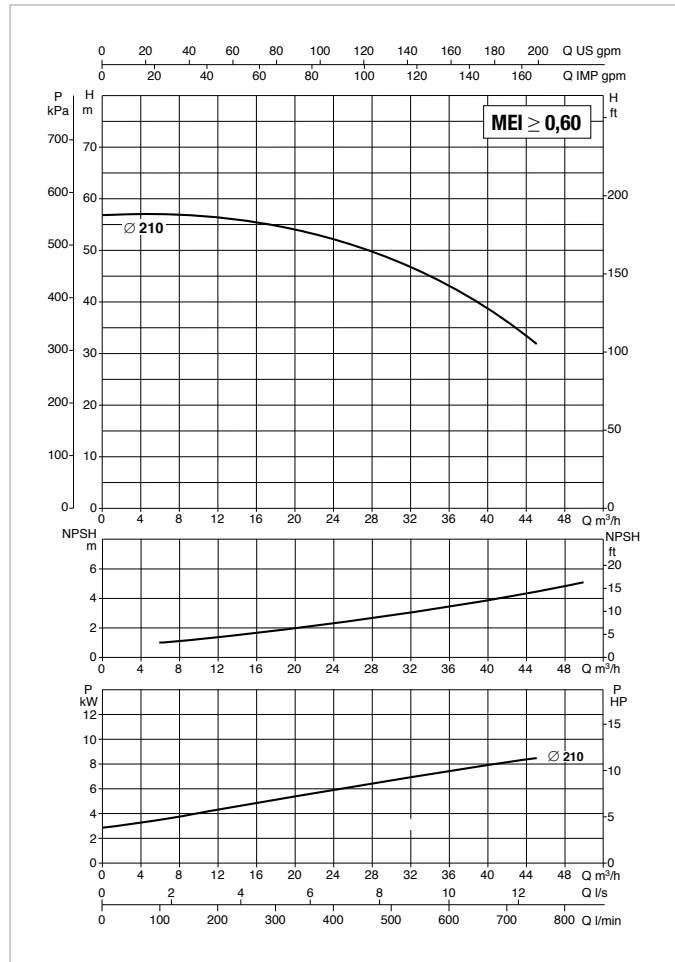
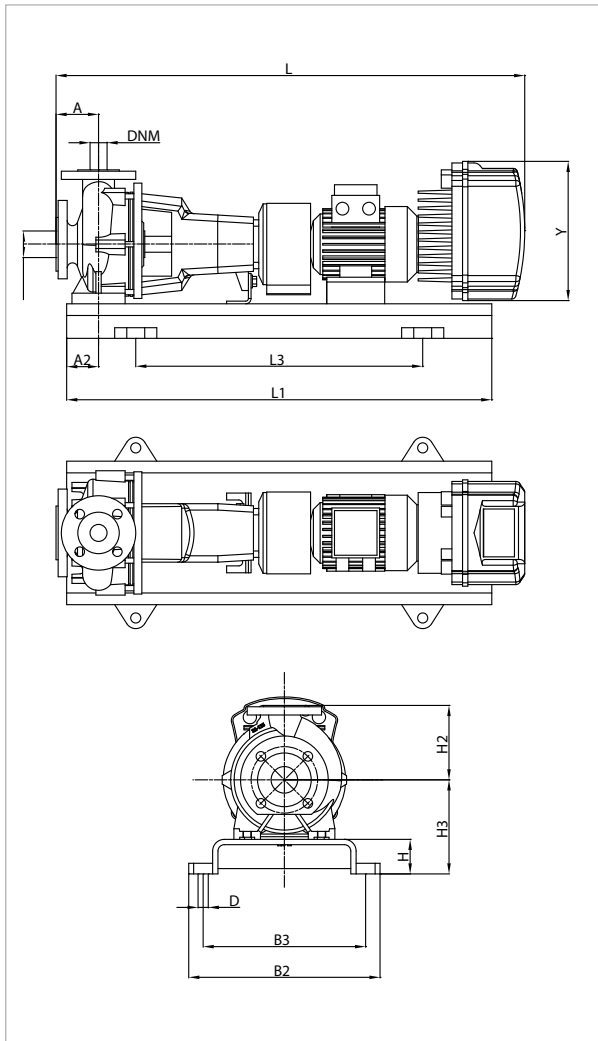

See hydraulic efficiency details on page 241.

The performance curves are based on kinematic viscosity values = 1 mm²/s and density equal to 1000 kg/m³. Curve tolerance according to ISO 9906.

MODEL	MCE MODEL	POWER INPUT 50 Hz	P2 NOMINAL		In A
			kW	HP	
KDNE 32-200/210/A/BAQE/1/ 11/2 MCE150/P	MCE150/P	3 x 400 ~V	11	15	25,5

MODEL	A	A2	H2	H	H3	L1	L3	B2	B3	D	Y	FLANGE DIMENSIONS (mm)		STANDARD COUPLING		SPACER COUPLING	
												DNA	DNM	L	WEIGHT kg	L	WEIGHT kg
												KDNE 32-200/210/A/BAQE/1/ 11/2 MCE150/P	80	60	180	80	240

KDNE 32-200 - 2 POLES - STANDARDISED CENTRIFUGAL ELECTRIC PUMPS WITH INVERTER FOR CIRCULATION OR PRESSURISATION SYSTEMS



Pumped liquid temperature range: from -10 °C to +140 °C (MCE/C) - from -10 °C to +80 °C (MCE/P) - Maximum ambient temperature: +40 °C = 2900 1/min

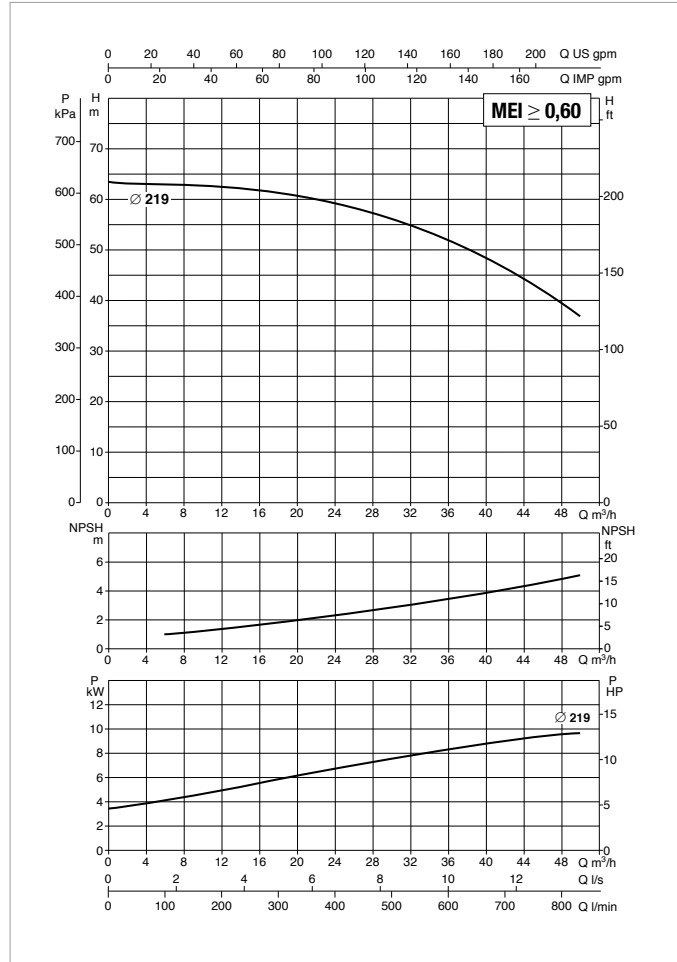
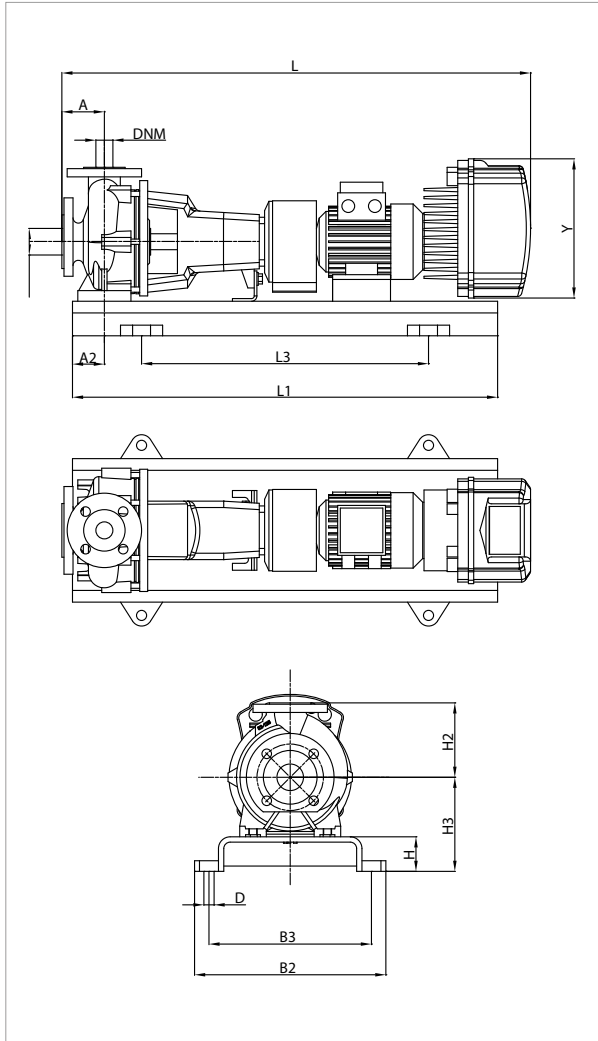

See hydraulic efficiency details on page 241.

The performance curves are based on kinematic viscosity values = 1 mm²/s and density equal to 1000 kg/m³. Curve tolerance according to ISO 9906.

MODEL	MCE MODEL	POWER INPUT 50 Hz	P2 NOMINAL		In A
			kW	HP	
KDNE 32-200/219/A/BAQE/1/15/2 T MCE150/C-P	MCE150/C - MCE150/P	3 x 400 ~V	15	20	34,0

MODEL	A	A2	H2	H	H3	L1	L3	B2	B3	D	Y	FLANGE DIMENSIONS (mm)		STANDARD COUPLING		SPACER COUPLING	
												DNA	DNM	L	WEIGHT kg	L	WEIGHT kg
												KDNE 32-200/219/A/BAQE/1/15/2 T MCE150/C-P	80	60	180	80	240

KDNE 40-125 - 2 POLES - STANDARDISED CENTRIFUGAL ELECTRIC PUMPS WITH INVERTER FOR CIRCULATION SYSTEMS



Pumped liquid temperature range: from -10 °C to +140 °C (MCE/C) - Maximum ambient temperature: +40 °C

= 2900 1/min

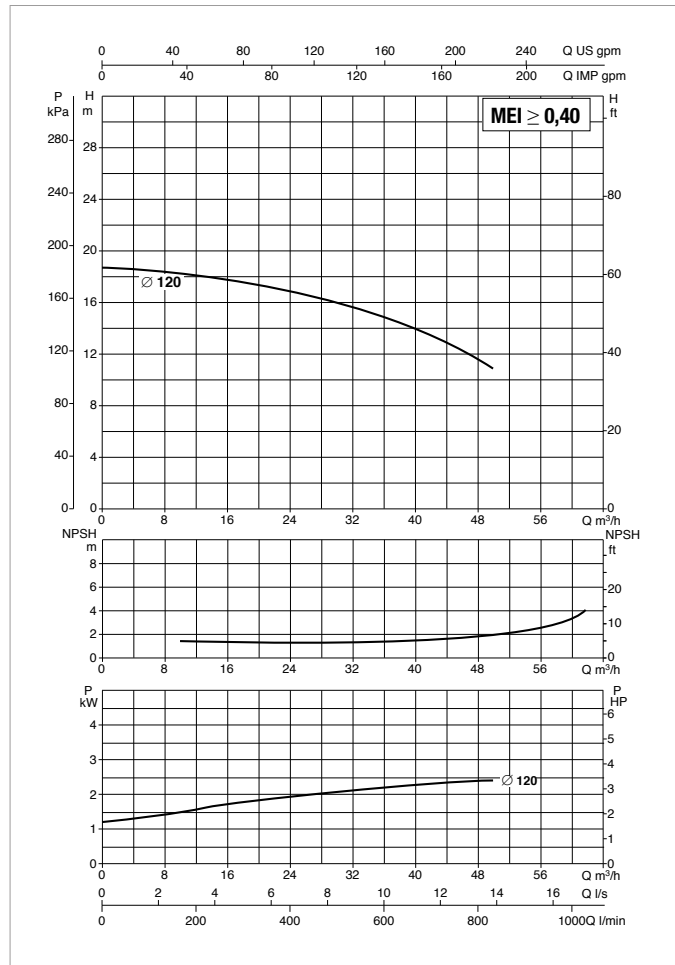
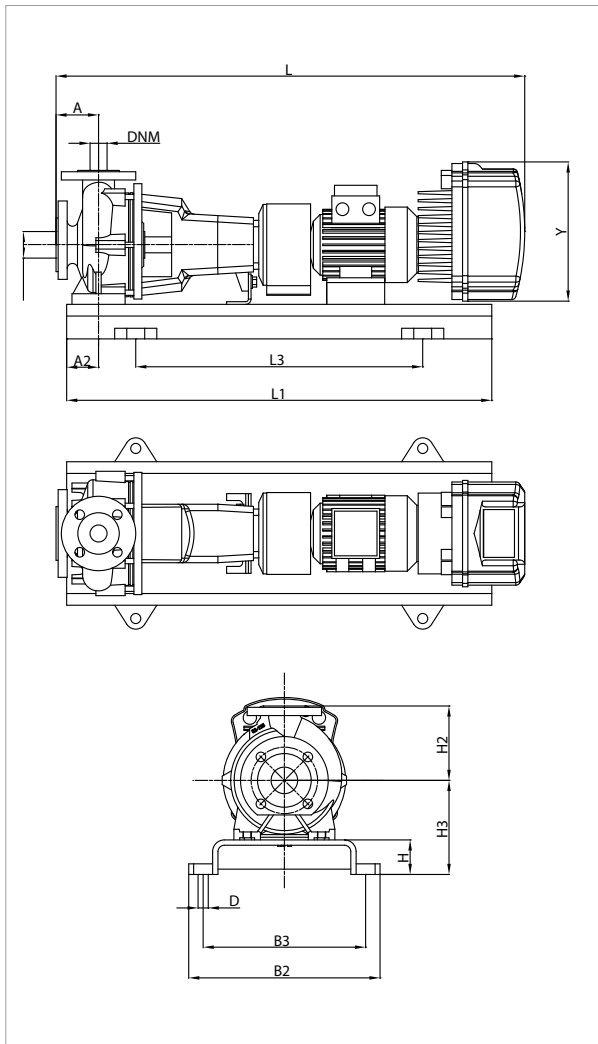

See hydraulic efficiency details on page 241.

The performance curves are based on kinematic viscosity values = 1 mm²/s and density equal to 1000 kg/m³. Curve tolerance according to ISO 9906.

MODEL	MCE MODEL	POWER INPUT 50 Hz	P2 NOMINAL		In A
			kW	HP	
KDNE 40-125/120/A/BAQE/1/3/2 T MCE30/C	MCE30/C	3 x 400 ~V	3	4	7,4

MODEL	A	A2	H2	H	H3	L1	L3	B2	B3	D	Y	FLANGE DIMENSIONS (mm)		STANDARD COUPLING		SPACER COUPLING	
												DNA	DNM	L	WEIGHT kg	L	WEIGHT kg
												KDNE 40-125/120/A/BAQE/1/3/2 T MCE30/C	80	60	140	65	177

KDNE 40-125 - 2 POLES - STANDARDISED CENTRIFUGAL ELECTRIC PUMPS WITH INVERTER FOR CIRCULATION OR PRESSURISATION SYSTEMS

MCE-C

MCE-P

Pumped liquid temperature range: from -10 °C to +140 °C (MCE/C) - from -10 °C to +80 °C (MCE/P) - Maximum ambient temperature: +40 °C = 2900 l/min

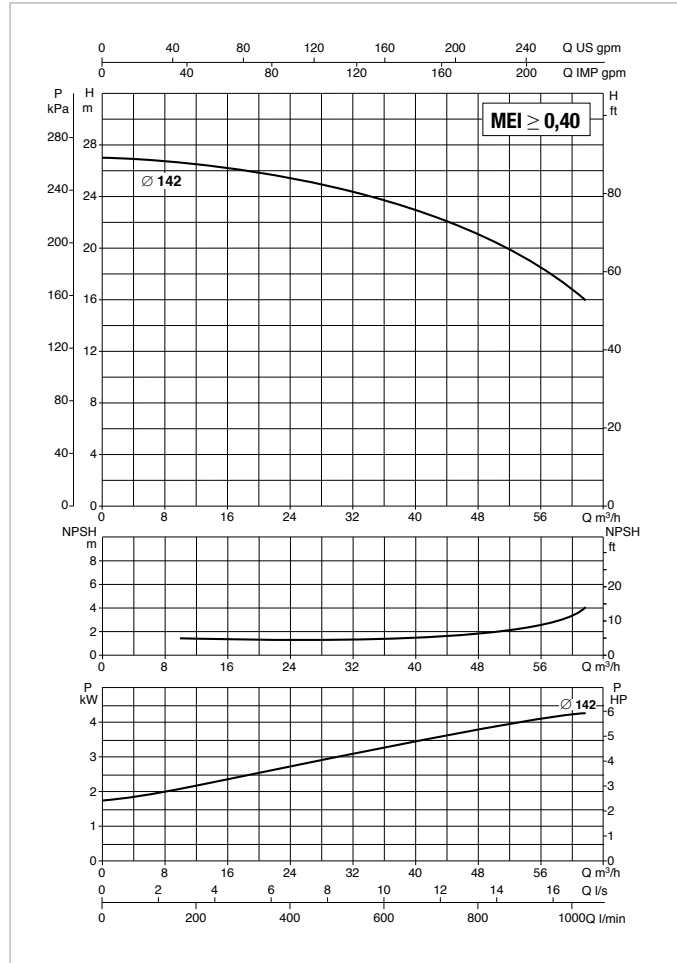
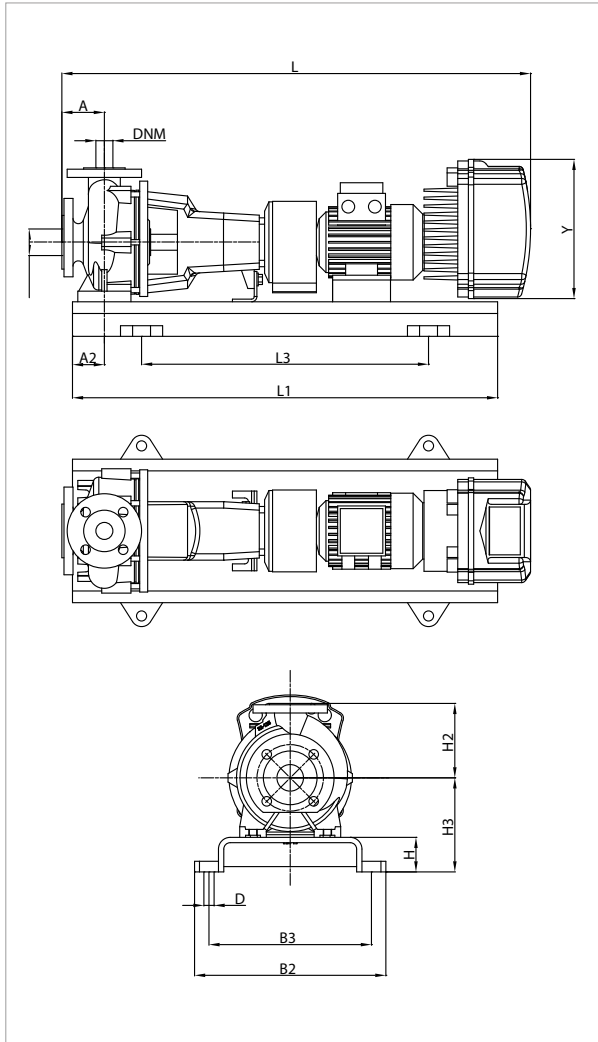

See hydraulic efficiency details on page 241.

The performance curves are based on kinematic viscosity values = 1 mm²/s and density equal to 1000 kg/m³. Curve tolerance according to ISO 9906.

MODEL	MCE MODEL	POWER INPUT 50 Hz	P2 NOMINAL		In A
			kW	HP	
KDNE 40-125/142/A/BAQE/1/5,5/2 T MCE55/C-P	MCE55/C - MCE55/P	3 x 400 ~V	5,5	7,5	13,1

MODEL	A	A2	H2	H	H3	L1	L3	B2	B3	D	Y	FLANGE DIMENSIONS (mm)		STANDARD COUPLING		SPACER COUPLING	
												DNA	DNM	L	WEIGHT kg	L	WEIGHT kg
												KDNE 40-125/142/A/BAQE/1/5,5/2 T MCE55/C-P	80	60	140	80	212

KDNE 40-160 - 2 POLES - STANDARDISED CENTRIFUGAL ELECTRIC PUMPS WITH INVERTER FOR CIRCULATION OR PRESSURISATION SYSTEMS

MCE-C

MCE-P

Pumped liquid temperature range: from -10 °C to +140 °C (MCE/C) - from -10 °C to +80 °C (MCE/P) - Maximum ambient temperature: +40 °C = 2900 1/min

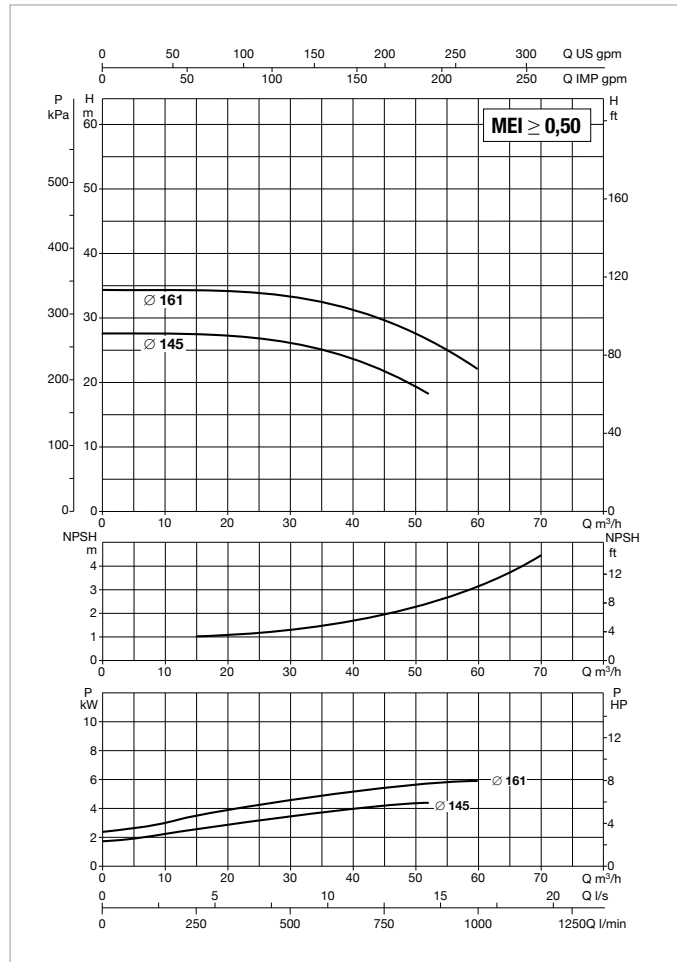
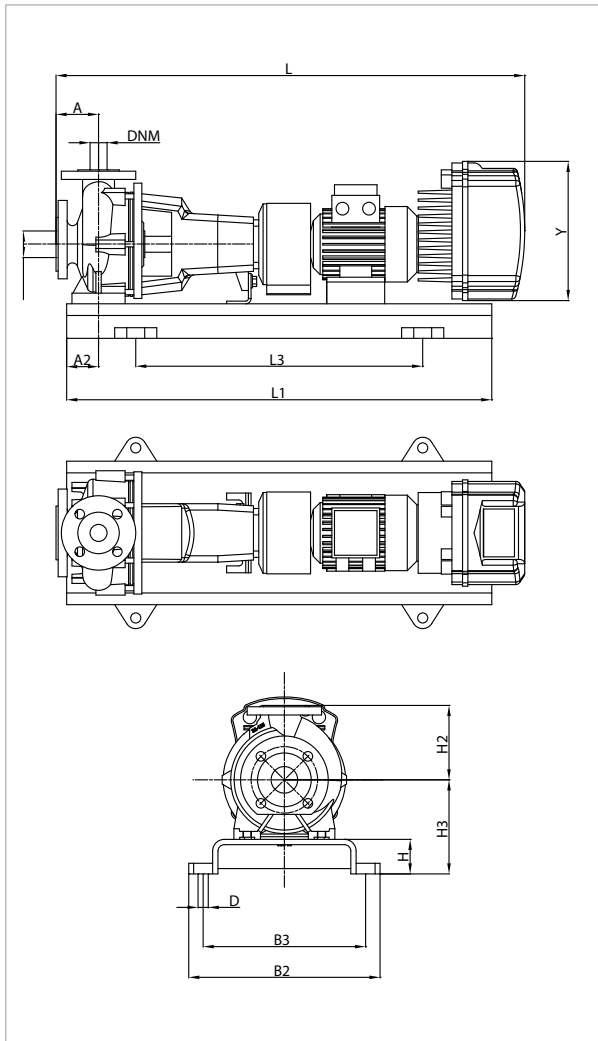

See hydraulic efficiency details on page 241.

The performance curves are based on kinematic viscosity values = 1 mm²/s and density equal to 1000 kg/m³. Curve tolerance according to ISO 9906.

MODEL	MCE MODEL	POWER INPUT 50 Hz	P2 NOMINAL		In A
			kW	HP	
KDNE 40-160/145/A/BAQE/1/5,5/2 T MCE55/C-P	MCE55/C - MCE55/P	3 x 400 ~V	5,5	7,5	13,1
KDNE 40-160/161/A/BAQE/1/7,5/2 T MCE110/C-P	MCE110/C - MCE110/P	3 x 400 ~V	7,5	10	17,6

MODEL	A	A2	H2	H	H3	L1	L3	B2	B3	D	Y	FLANGE DIMENSIONS (mm)		STANDARD COUPLING		SPACER COUPLING	
												DNA	DNM	L	WEIGHT kg	L	WEIGHT kg
												KDNE 40-160/145/A/BAQE/1/5,5/2 T MCE55/C-P	80	60	160	80	212
KDNE 40-160/161/A/BAQE/1/7,5/2 T MCE110/C-P	80	60	160	80	212	1000	660	450	400	24	426	65	40	1209	178	1309	183

KDNE 40-160 - 2 POLES - STANDARDISED CENTRIFUGAL ELECTRIC PUMPS WITH INVERTER FOR CIRCULATION SYSTEMS



Pumped liquid temperature range: from -10 °C to +140 °C (MCE/C) - Maximum ambient temperature: +40 °C

= 2900 1/min

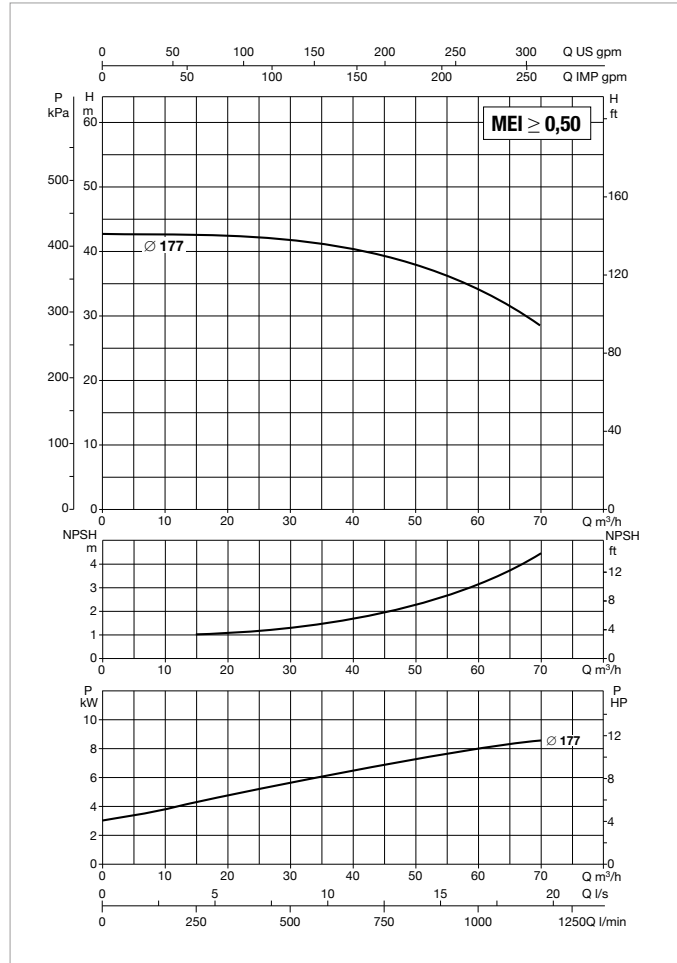
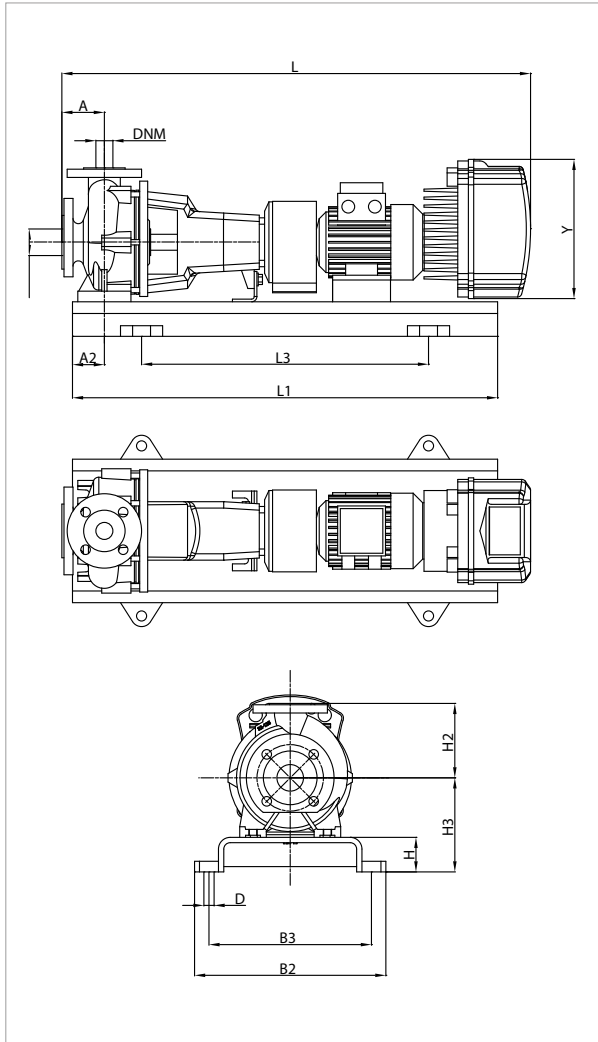

See hydraulic efficiency details on page 241.

The performance curves are based on kinematic viscosity values = 1 mm²/s and density equal to 1000 kg/m³. Curve tolerance according to ISO 9906.

MODEL	MCE MODEL	POWER INPUT 50 Hz	P2 NOMINAL		In A
			kW	HP	
KDNE 40-160/177/A/BAQE/1/11/2 T MCE110/C	MCE110/C	3 x 400 ~V	11	15	25,5

MODEL	A	A2	H2	H	H3	L1	L3	B2	B3	D	Y	FLANGE DIMENSIONS (mm)		STANDARD COUPLING		SPACER COUPLING	
												DNA	DNM	L	WEIGHT kg	L	WEIGHT kg
												KDNE 40-160/177/A/BAQE/1/11/2 T MCE110/C	80	60	160	80	240

KDNE 40-160 - 2 POLES - STANDARDISED CENTRIFUGAL ELECTRIC PUMPS WITH INVERTER FOR PRESSURISATION SYSTEMS



Pumped liquid temperature range: from -10 °C to +80 °C (MCE/P) - Maximum ambient temperature: +40 °C

= 2900 1/min

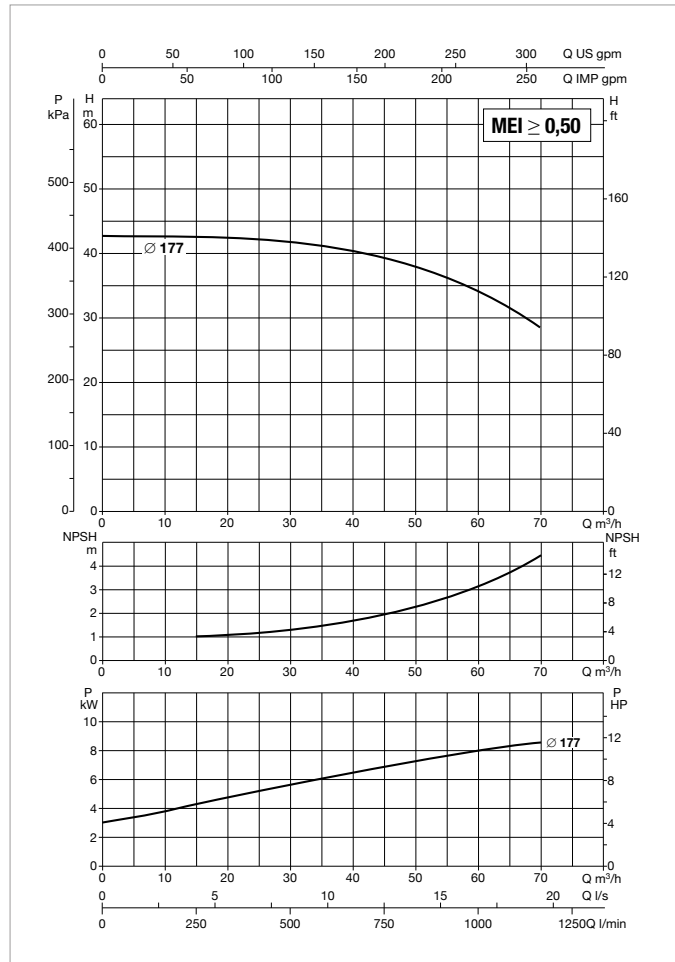
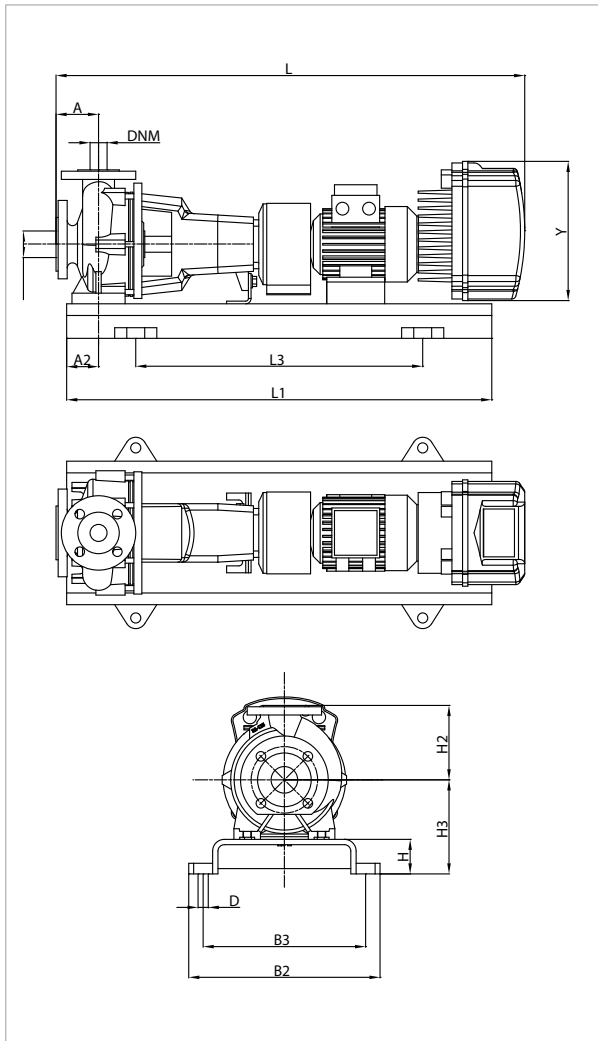

See hydraulic efficiency details on page 241.

The performance curves are based on kinematic viscosity values = 1 mm²/s and density equal to 1000 kg/m³. Curve tolerance according to ISO 9906.

MODEL	MCE MODEL	POWER INPUT 50 Hz	P2 NOMINAL		In A
			kW	HP	
KDNE 40-160/177/A/BAQE/1/11/2 MCE150/P	MCE150/P	3 x 400 ~V	11	15	25,5

MODEL	A	A2	H2	H	H3	L1	L3	B2	B3	D	Y	FLANGE DIMENSIONS (mm)		STANDARD COUPLING		SPACER COUPLING	
												DNA	DNM	L	WEIGHT kg	L	WEIGHT kg
												KDNE 40-160/177/A/BAQE/1/11/2 MCE150/P	80	60	160	80	240

KDNE 40-200 - 2 POLES - STANDARDISED CENTRIFUGAL ELECTRIC PUMPS WITH INVERTER FOR CIRCULATION OR PRESSURISATION SYSTEMS



Pumped liquid temperature range: from -10 °C to +140 °C (MCE/C) - from -10 °C to +80 °C (MCE/P) - Maximum ambient temperature: +40 °C = 2900 l/min

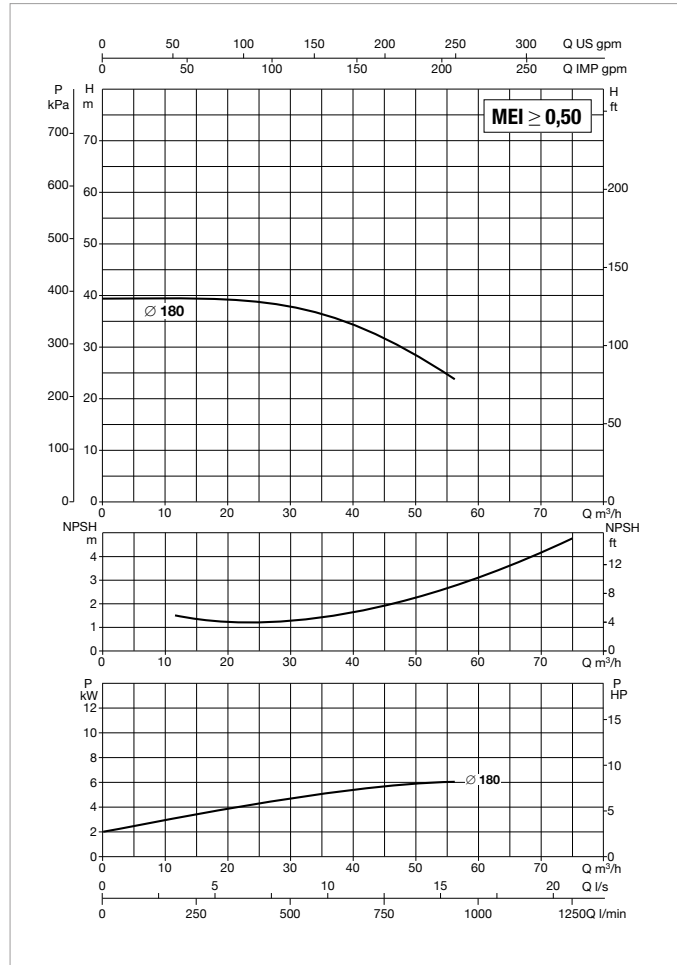
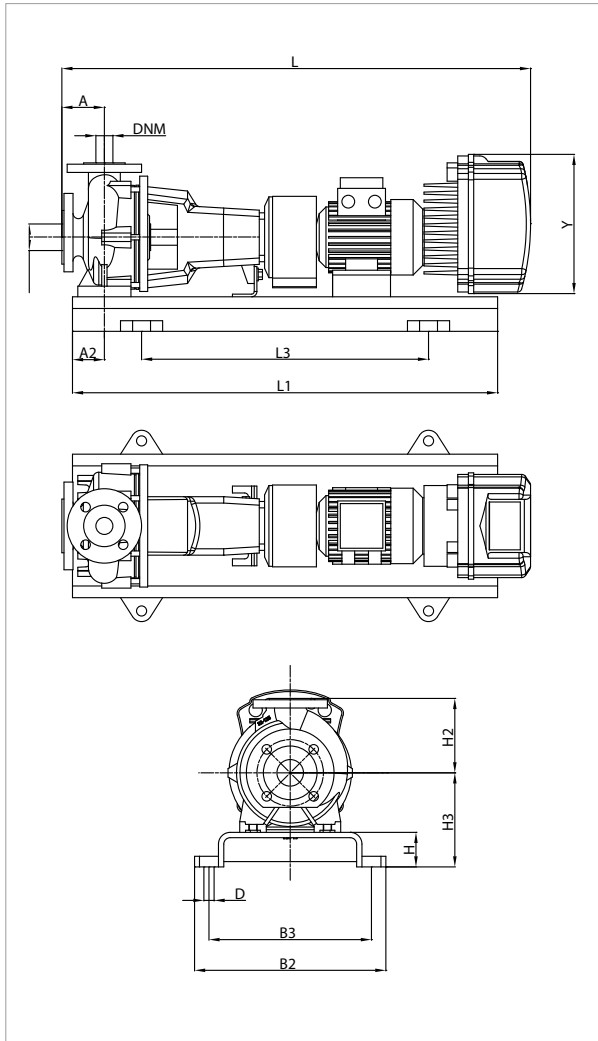

See hydraulic efficiency details on page 241.

The performance curves are based on kinematic viscosity values = 1 mm²/s and density equal to 1000 kg/m³. Curve tolerance according to ISO 9906.

MODEL	MCE MODEL	POWER INPUT 50 Hz	P2 NOMINAL		In A
			kW	HP	
KDNE 40-200/180/A/BAQE/1/7,5/2 T MCE110/C-P	MCE110/C - MCE110/P	3 x 400 ~V	7,5	10	17,6

MODEL	A	A2	H2	H	H3	L1	L3	B2	B3	D	Y	FLANGE DIMENSIONS (mm)		STANDARD COUPLING		SPACER COUPLING	
												DNA	DNM	L	WEIGHT kg	L	WEIGHT kg
												KDNE 40-200/180/A/BAQE/1/7,5/2 T MCE110/C-P	100	60	180	80	240

KDNE 40-200 - 2 POLES - STANDARDISED CENTRIFUGAL ELECTRIC PUMPS WITH INVERTER FOR CIRCULATION SYSTEMS



Pumped liquid temperature range: from -10 °C to +140 °C (MCE/C) - Maximum ambient temperature: +40 °C

= 2900 1/min

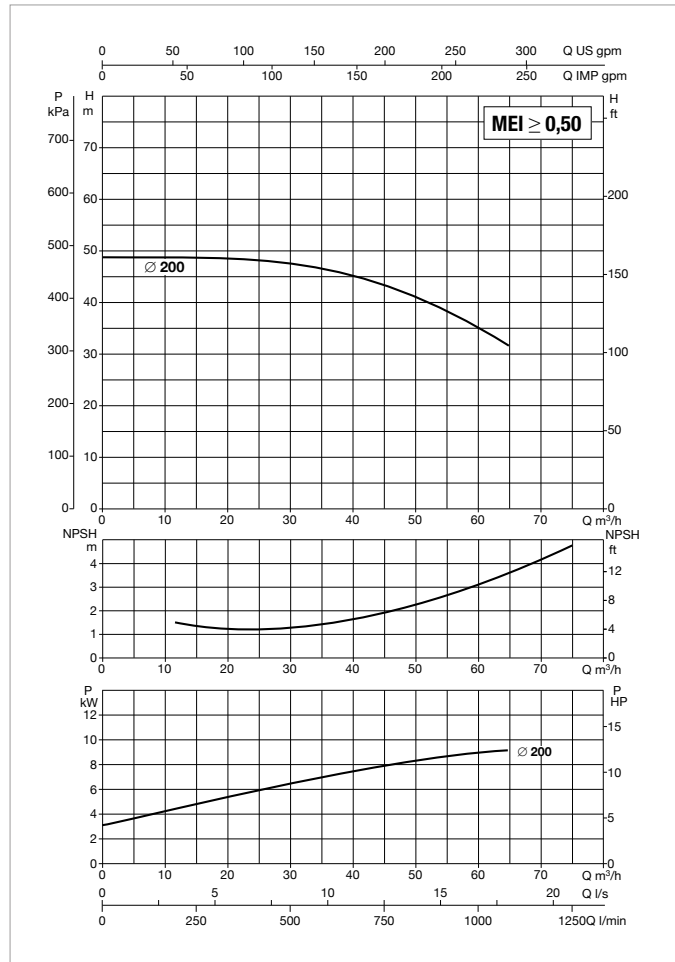
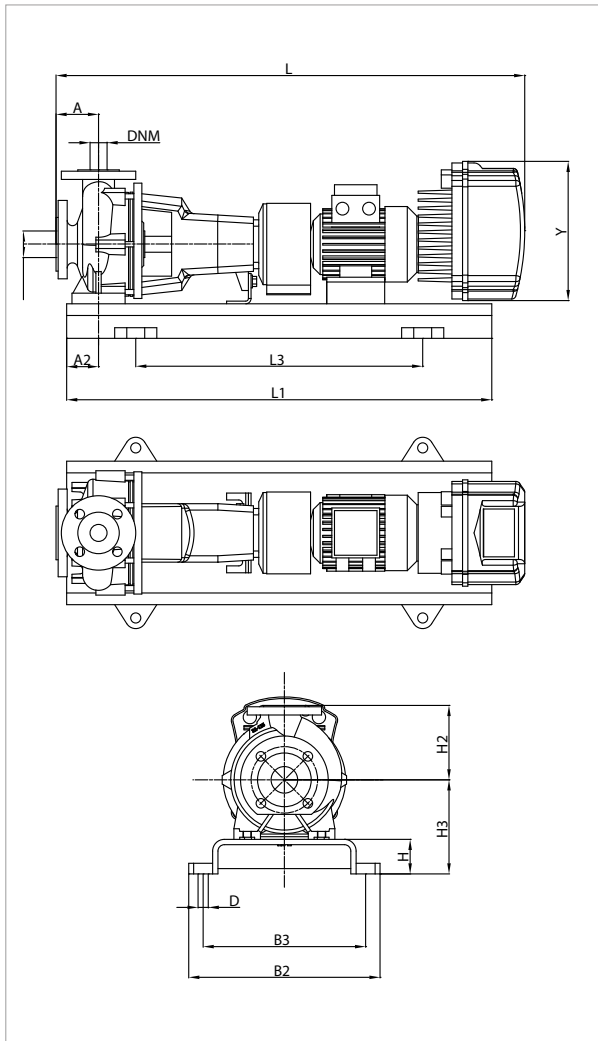

See hydraulic efficiency details on page 241.

The performance curves are based on kinematic viscosity values = 1 mm²/s and density equal to 1000 kg/m³. Curve tolerance according to ISO 9906.

MODEL	MCE MODEL	POWER INPUT 50 Hz	P2 NOMINAL		In A
			kW	HP	
KDNE 40-200/200/A/BAQE/1/11/2 T MCE110/C	MCE110/C	3 x 400 ~V	11	15	25,5

MODEL	A	A2	H2	H	H3	L1	L3	B2	B3	D	Y	FLANGE DIMENSIONS (mm)		STANDARD COUPLING		SPACER COUPLING	
												DNA	DNM	L	WEIGHT kg	L	WEIGHT kg
												KDNE 40-200/200/A/BAQE/1/11/2 T MCE110/C	100	60	180	80	240

KDNE 40-200 - 2 POLES - STANDARDISED CENTRIFUGAL ELECTRIC PUMPS WITH INVERTER FOR PRESSURIZATION SYSTEMS



Pumped liquid temperature range: from -10 °C to +80 °C (MCE/P) - Maximum ambient temperature: +40 °C

= 2900 1/min

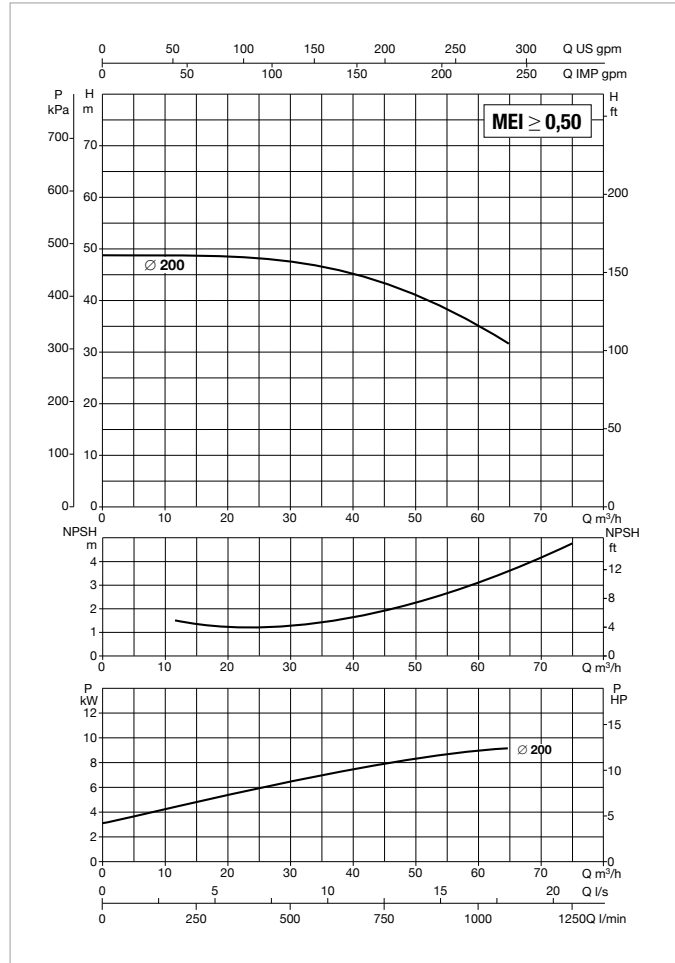
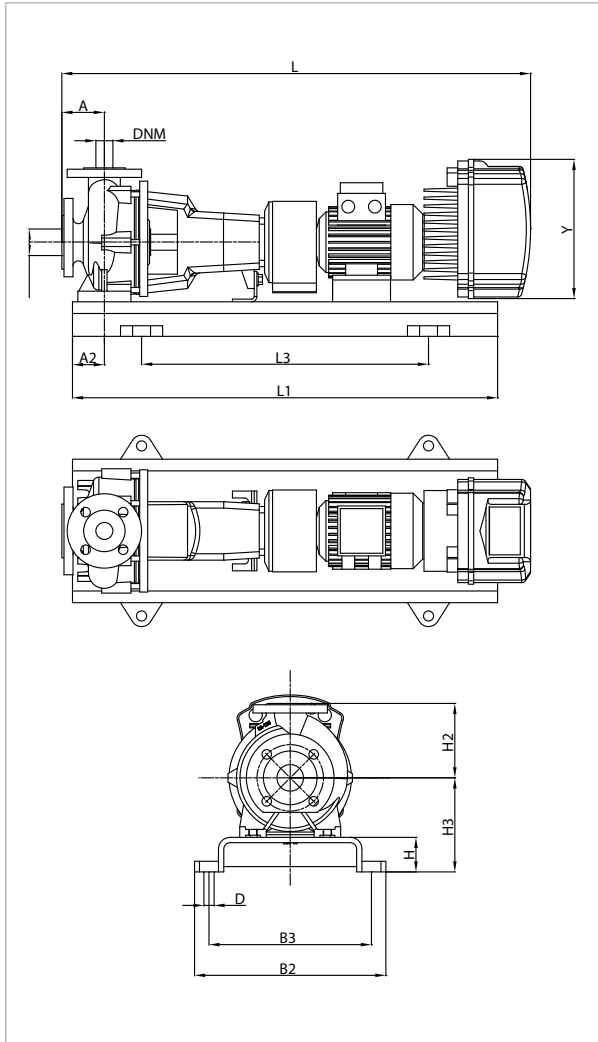

See hydraulic efficiency details on page 241.

The performance curves are based on kinematic viscosity values = 1 mm²/s and density equal to 1000 kg/m³. Curve tolerance according to ISO 9906.

MODEL	MCE MODEL	POWER INPUT 50 Hz	P2 NOMINAL		In A
			kW	HP	
KDNE 40-200/200/A/BAQE/1/11/2 MCE150/P	MCE150/P	3 x 400 ~V	11	15	25,5

MODEL	A	A2	H2	H	H3	L1	L3	B2	B3	D	Y	FLANGE DIMENSIONS (mm)		STANDARD COUPLING		SPACER COUPLING	
												DNA	DNM	L	WEIGHT kg	L	WEIGHT kg
												KDNE 40-200/200/A/BAQE/1/11/2 MCE150/P	100	60	180	80	240

KDNE 40-200 - 2 POLES - STANDARDISED CENTRIFUGAL ELECTRIC PUMPS WITH INVERTER FOR CIRCULATION OR PRESSURISATION SYSTEMS

MCE-C

MCE-P

Pumped liquid temperature range: from -10 °C to +140 °C (MCE/C) - from -10 °C to +80 °C (MCE/P) - Maximum ambient temperature: +40 °C
= 2900 1/min

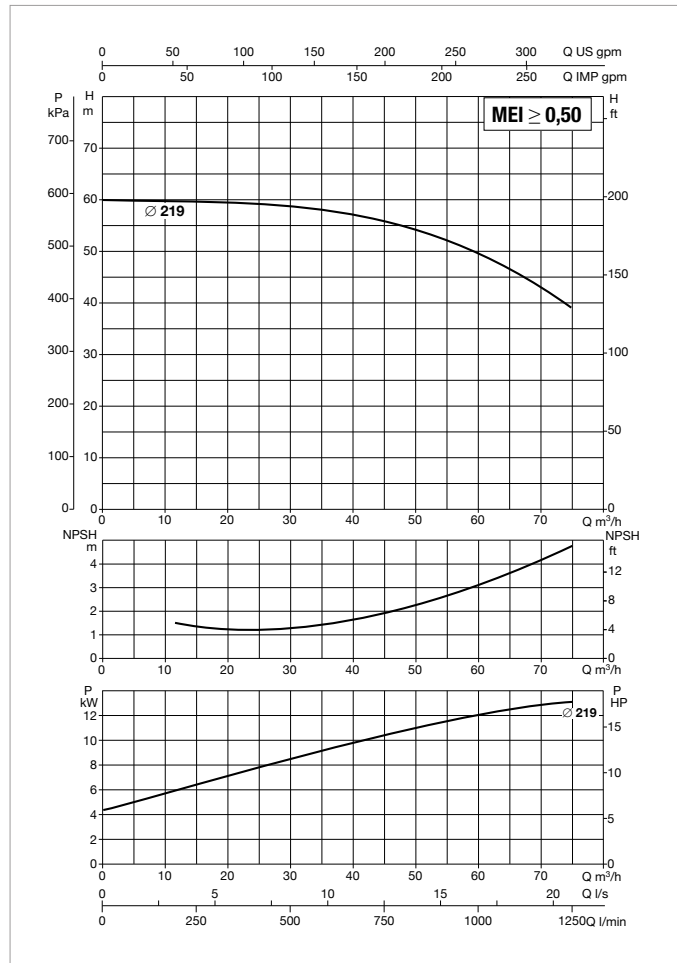
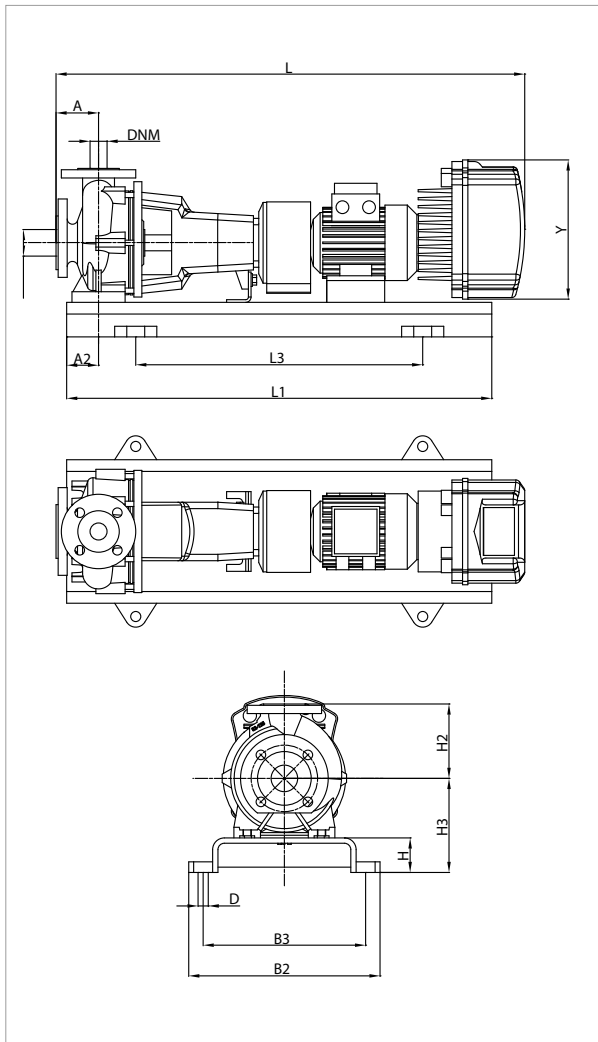

See hydraulic efficiency details on page 241.

The performance curves are based on kinematic viscosity values = 1 mm²/s and density equal to 1000 kg/m³. Curve tolerance according to ISO 9906.

MODEL	MCE MODEL	POWER INPUT 50 Hz	P2 NOMINAL		In A
			kW	HP	
KDNE 40-200/219/A/BAQE/1/15/2 T MCE150/C-P	MCE150/C - MCE150/P	3 x 400 ~V	15	20	34,0

MODEL	A	A2	H2	H	H3	L1	L3	B2	B3	D	Y	FLANGE DIMENSIONS (mm)		STANDARD COUPLING		SPACER COUPLING	
												DNA	DNM	L	WEIGHT kg	L	WEIGHT kg
												KDNE 40-200/219/A/BAQE/1/15/2 T MCE150/C-P	100	60	180	80	240

KDNE 40-250 - 2 POLES - STANDARDISED CENTRIFUGAL ELECTRIC PUMPS WITH INVERTER FOR CIRCULATION OR PRESSURISATION SYSTEMS



Pumped liquid temperature range: from -10 °C to +140 °C (MCE/C) - from -10 °C to +80 °C (MCE/P) - Maximum ambient temperature: +40 °C = 2900 l/min

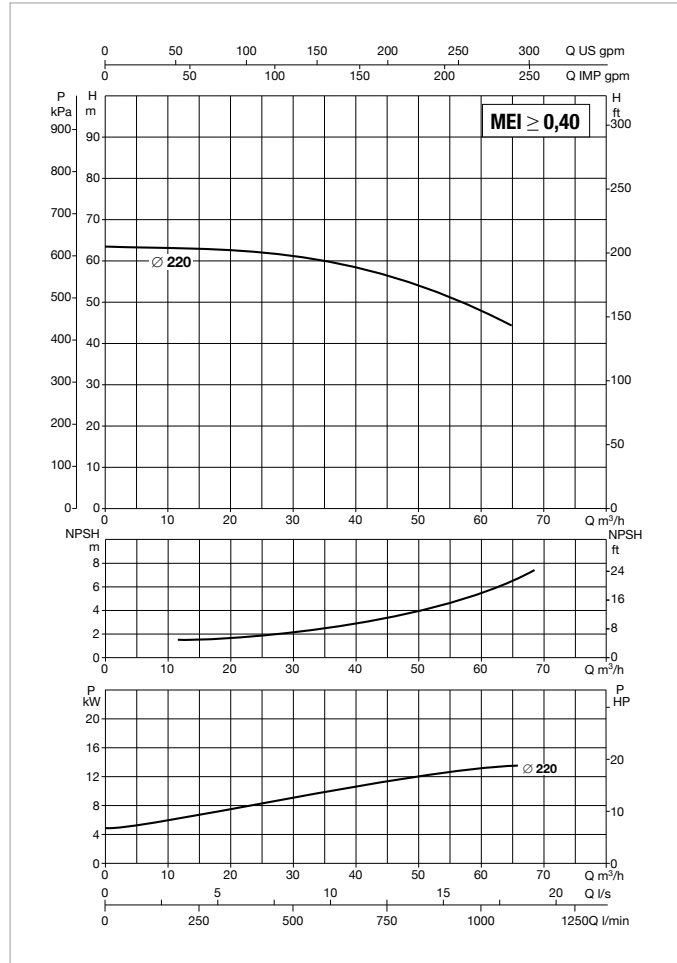
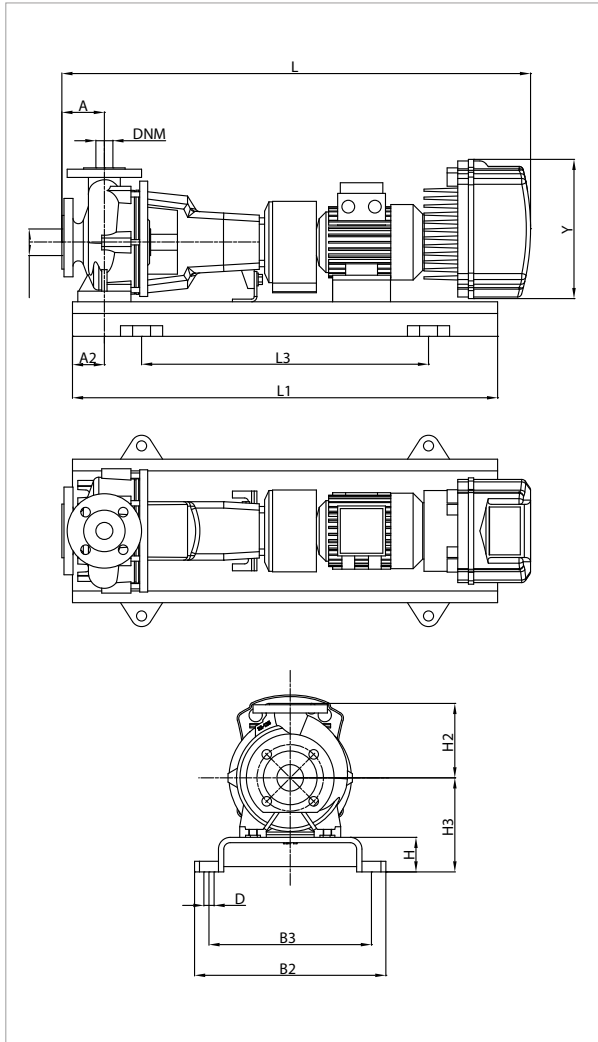

See hydraulic efficiency details on page 241.

The performance curves are based on kinematic viscosity values = 1 mm²/s and density equal to 1000 kg/m³. Curve tolerance according to ISO 9906.

MODEL	MCE MODEL	POWER INPUT 50 Hz	P2 NOMINAL		In A
			kW	HP	
KDNE 40-250/220/A/BAQE/1/15/2 T MCE150/C-P	MCE150/C - MCE150/P	3 x 400 ~V	15	20	34,0

MODEL	A	A2	H2	H	H3	L1	L3	B2	B3	D	Y	FLANGE DIMENSIONS (mm)		STANDARD COUPLING		SPACER COUPLING	
												DNA	DNM	L	WEIGHT kg	L	WEIGHT kg
												KDNE 40-250/220/A/BAQE/1/15/2 T MCE150/C-P	100	75	225	80	260

KDNE 50-125 - 2 POLES - STANDARDISED CENTRIFUGAL ELECTRIC PUMPS WITH INVERTER FOR CIRCULATION SYSTEMS



Pumped liquid temperature range: from -10 °C to +140 °C (MCE/C) - Maximum ambient temperature: +40 °C

= 2900 1/min

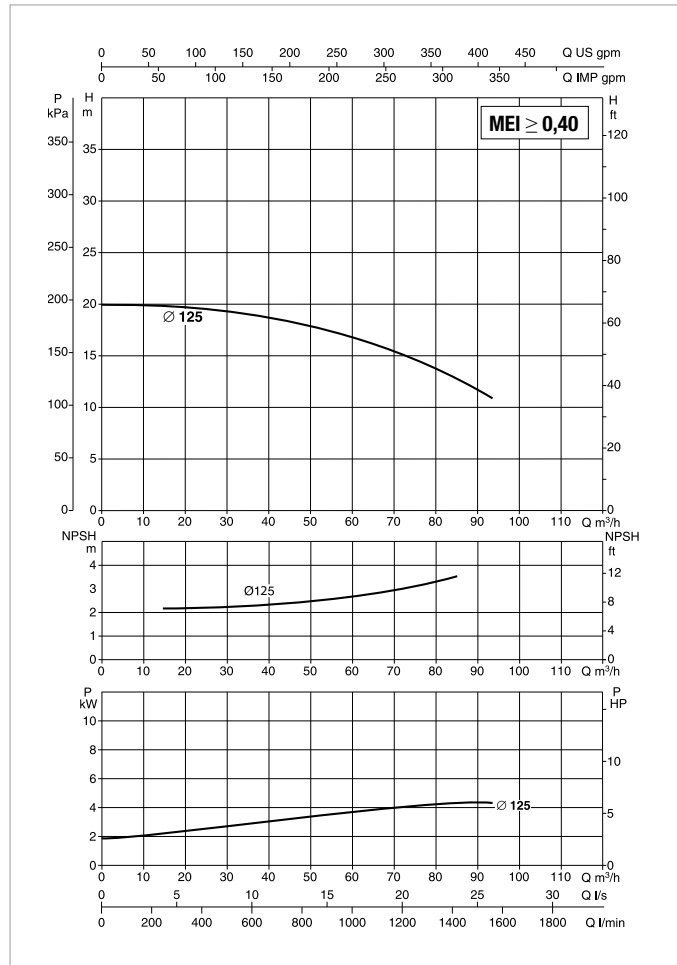
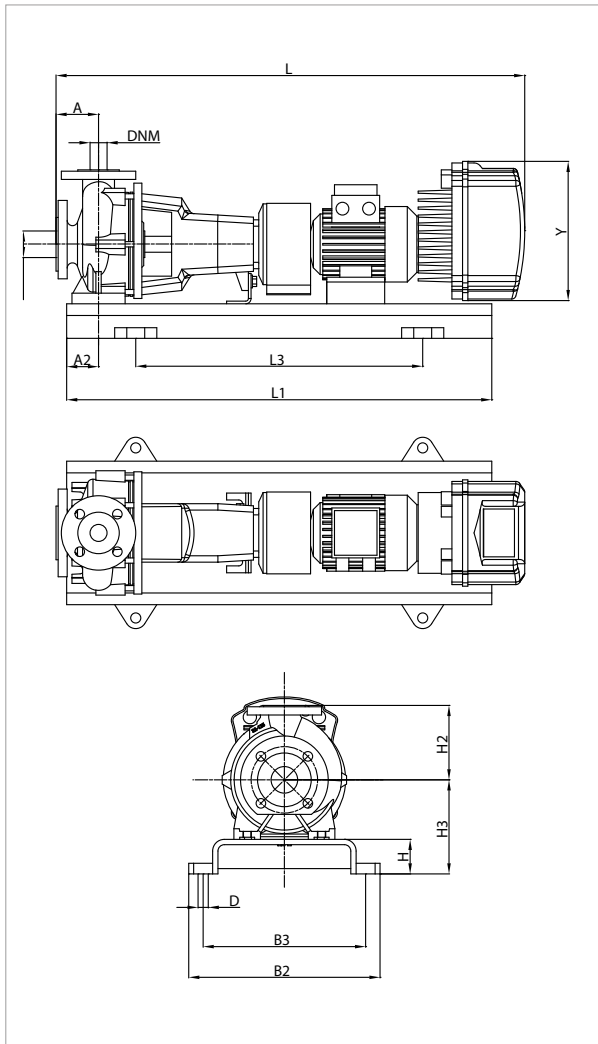

See hydraulic efficiency details on page 241.

The performance curves are based on kinematic viscosity values = 1 mm²/s and density equal to 1000 kg/m³. Curve tolerance according to ISO 9906.

MODEL	MCE MODEL	POWER INPUT 50 Hz	P2 NOMINAL		In A
			kW	HP	
KDNE 50-125/125/A/BAQE/1/5.5/2 T MCE55/C	MCE55/C	3 x 400 ~V	5,5	7,5	13,1

MODEL	A	A2	H2	H	H3	L1	L3	B2	B3	D	Y	FLANGE DIMENSIONS (mm)		STANDARD COUPLING		SPACER COUPLING	
												DNA	DNM	L	WEIGHT kg	L	WEIGHT kg
												KDNE 50-125/125/A/BAQE/1/5.5/2 T MCE55/C	100	60	160	80	212

KDNE 50-125 - 2 POLES - STANDARDISED CENTRIFUGAL ELECTRIC PUMPS WITH INVERTER FOR CIRCULATION OR PRESSURISATION SYSTEMS



Pumped liquid temperature range: from -10 °C to +140 °C (MCE/C) - from -10 °C to +80 °C (MCE/P) - Maximum ambient temperature: +40 °C = 2900 1/min

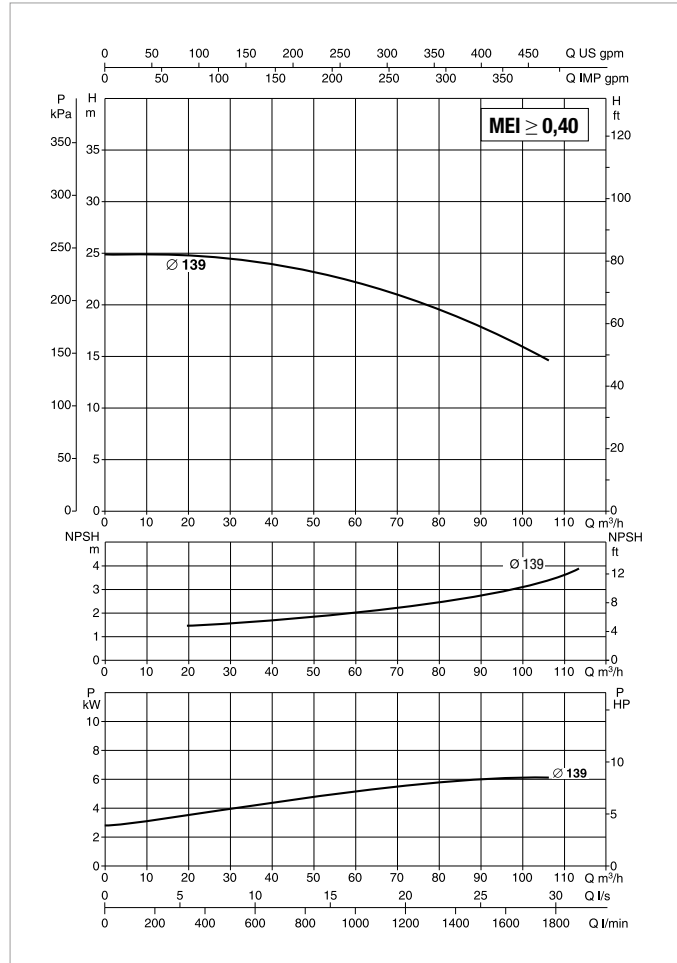
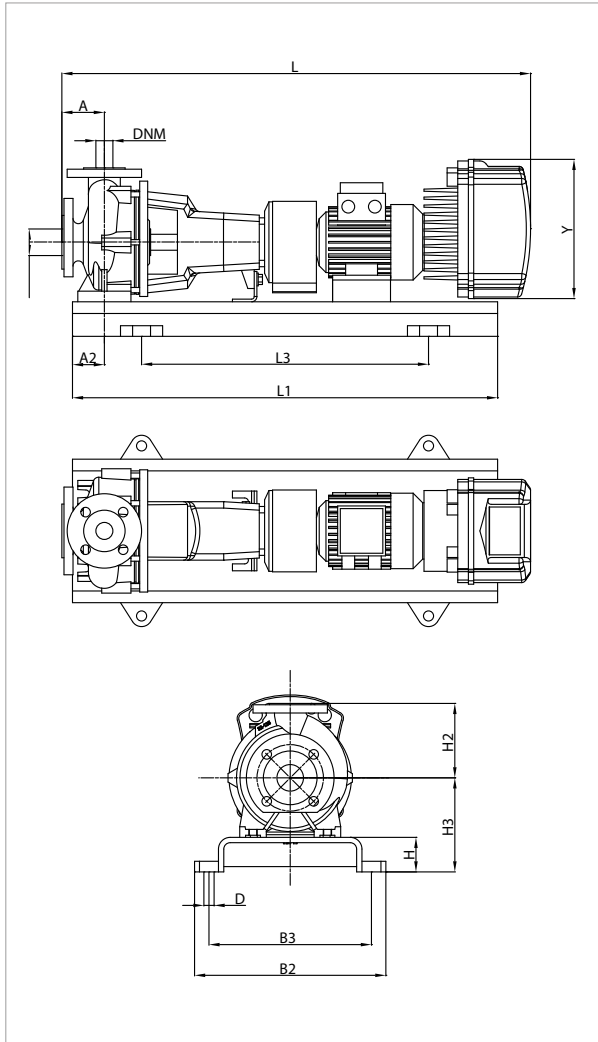

See hydraulic efficiency details on page 241.

The performance curves are based on kinematic viscosity values = 1 mm²/s and density equal to 1000 kg/m³. Curve tolerance according to ISO 9906.

MODEL	MCE MODEL	POWER INPUT 50 Hz	P2 NOMINAL		In A
			kW	HP	
KDNE 50-125/139/A/BAQE/1/7,5/2 T MCE110/C-P	MCE110/C - MCE110/P	3 x 400 ~V	7,5	10	17,6

MODEL	A	A2	H2	H	H3	L1	L3	B2	B3	D	Y	FLANGE DIMENSIONS (mm)		STANDARD COUPLING		SPACER COUPLING	
												DNA	DNM	L	WEIGHT kg	L	WEIGHT kg
												KDNE 50-125/139/A/BAQE/1/7,5/2 T MCE110/C-P	100	60	160	80	212

KDNE 50-125 - 2 POLES - STANDARDISED CENTRIFUGAL ELECTRIC PUMPS WITH INVERTER FOR CIRCULATION SYSTEMS



Pumped liquid temperature range: from -10 °C to +140 °C (MCE/C) - Maximum ambient temperature: +40 °C

= 2900 1/min

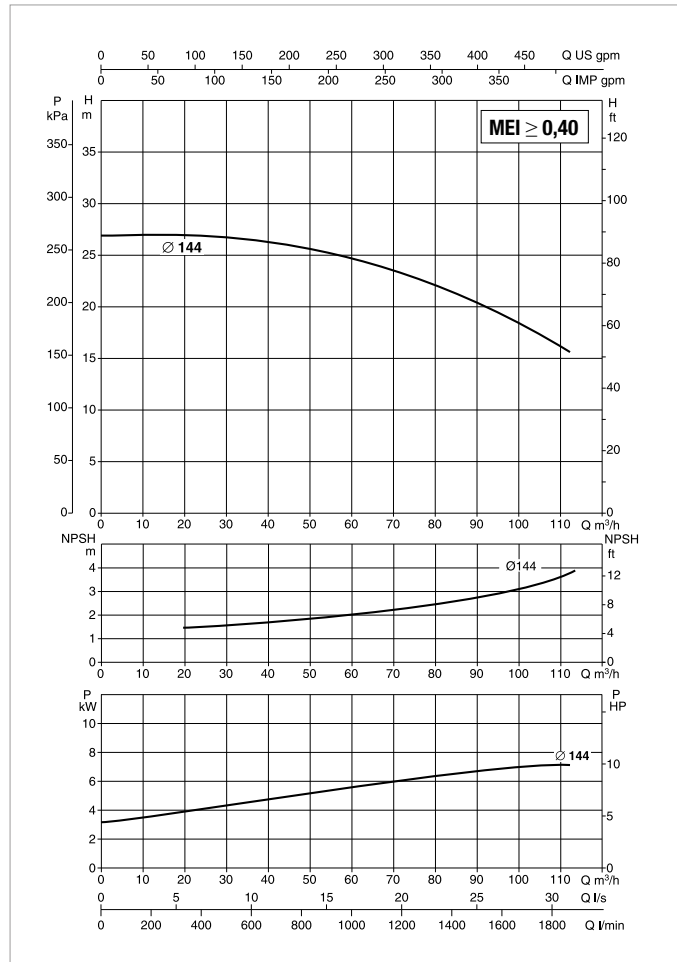
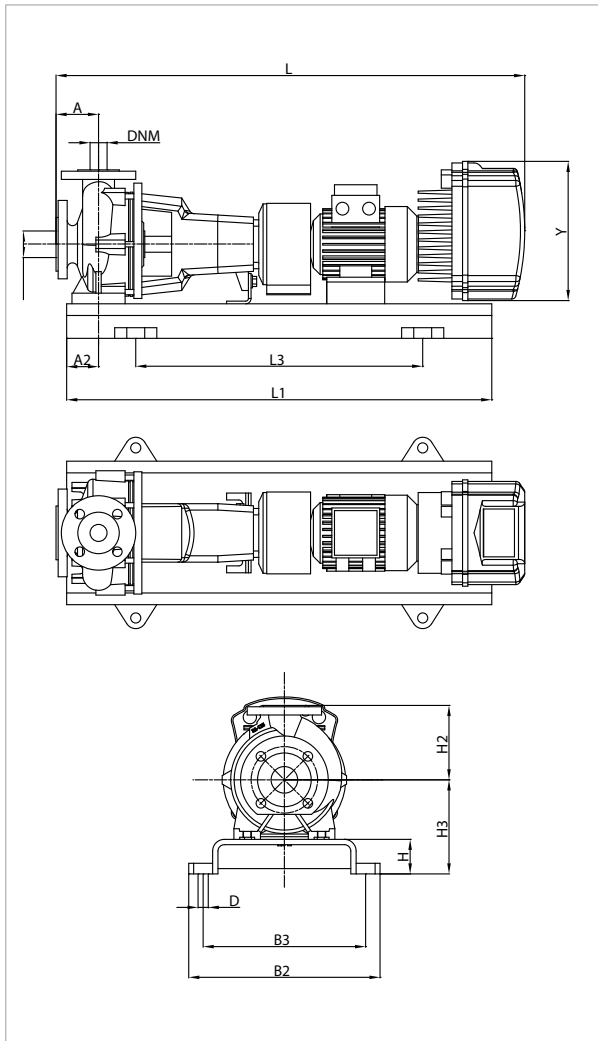

See hydraulic efficiency details on page 241.

The performance curves are based on kinematic viscosity values = 1 mm²/s and density equal to 1000 kg/m³. Curve tolerance according to ISO 9906.

MODEL	MCE MODEL	POWER INPUT 50 Hz	P2 NOMINAL		In A
			kW	HP	
KDNE 50-125/144/A/BAQE/1/11/2 T MCE110/C	MCE110/C	3 x 400 ~V	11	15	25,5

MODEL	A	A2	H2	H	H3	L1	L3	B2	B3	D	Y	FLANGE DIMENSIONS (mm)		STANDARD COUPLING		SPACER COUPLING	
												DNA	DNM	L	WEIGHT kg	L	WEIGHT kg
												KDNE 50-125/144/A/BAQE/1/11/2 T MCE110/C	100	60	160	80	240

KDNE 50-125 - 2 POLES - STANDARDISED CENTRIFUGAL ELECTRIC PUMPS WITH INVERTER FOR PRESSURISATION SYSTEMS



Pumped liquid temperature range: from -10 °C to +80 °C (MCE/P) - Maximum ambient temperature: +40 °C

= 2900 1/min

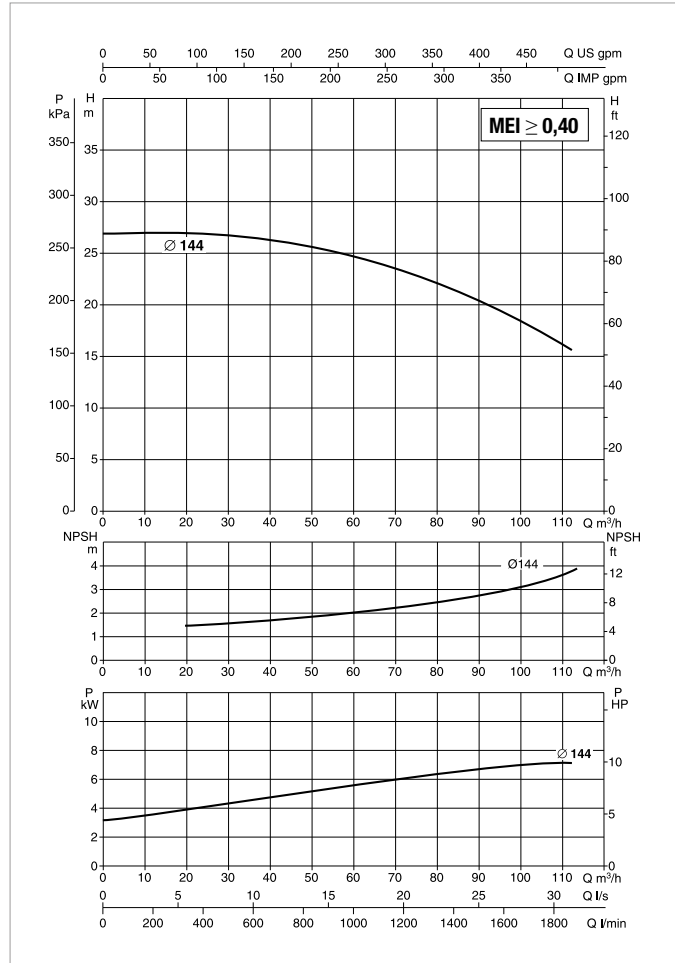
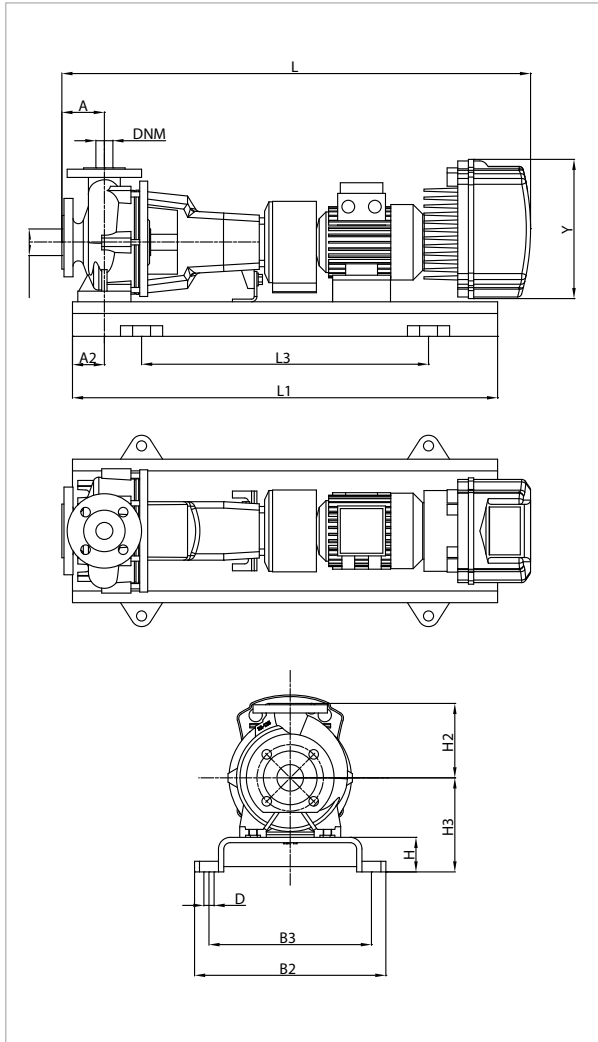

See hydraulic efficiency details on page 241.

The performance curves are based on kinematic viscosity values = 1 mm²/s and density equal to 1000 kg/m³. Curve tolerance according to ISO 9906.

MODEL	MCE MODEL	POWER INPUT 50 Hz	P2 NOMINAL		In A
			kW	HP	
KDNE 50-125/144/A/BAQE/1/11/2 MCE150/P	MCE150/P	3 x 400 ~V	11	15	25,5

MODEL	A	A2	H2	H	H3	L1	L3	B2	B3	D	Y	FLANGE DIMENSIONS (mm)		STANDARD COUPLING		SPACER COUPLING	
												DNA	DNM	L	WEIGHT kg	L	WEIGHT kg
												KDNE 50-125/144/A/BAQE/1/11/2 MCE150/P	100	60	160	80	240

KDNE 50-160 - 2 POLES - STANDARDISED CENTRIFUGAL ELECTRIC PUMPS WITH INVERTER FOR CIRCULATION OR PRESSURISATION SYSTEMS

MCE-C

MCE-P

Pumped liquid temperature range: from -10 °C to +140 °C (MCE/C) - from -10 °C to +80 °C (MCE/P) - Maximum ambient temperature: +40 °C
= 2900 1/min

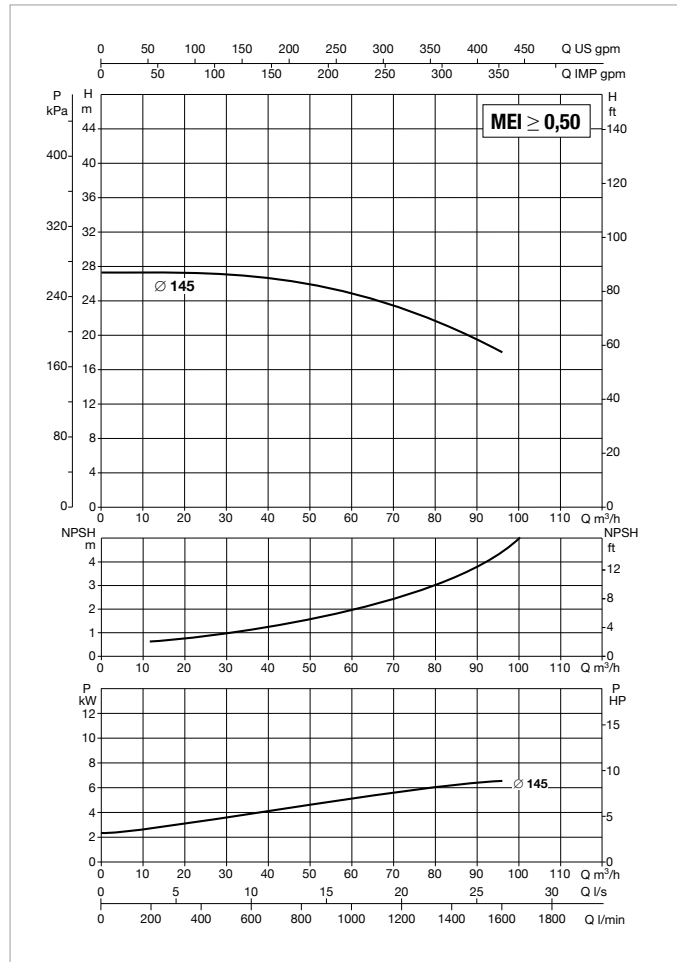
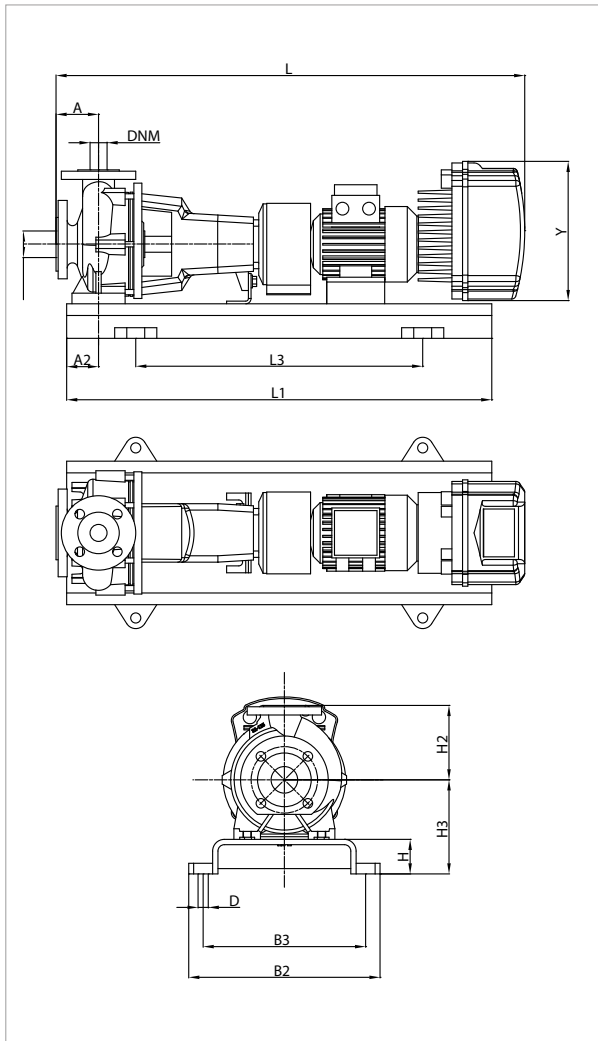

See hydraulic efficiency details on page 241.

The performance curves are based on kinematic viscosity values = 1 mm²/s and density equal to 1000 kg/m³. Curve tolerance according to ISO 9906.

MODEL	MCE MODEL	POWER INPUT 50 Hz	P2 NOMINAL		In A
			kW	HP	
KDNE 50-160/145/A/BAQE/1/7,5/2 T MCE110/C-P	MCE110/C - MCE110/P	3 x 400 ~V	7,5	10	17,6

MODEL	A	A2	H2	H	H3	L1	L3	B2	B3	D	Y	FLANGE DIMENSIONS (mm)		STANDARD COUPLING		SPACER COUPLING	
												DNA	DNM	L	WEIGHT kg	L	WEIGHT kg
												KDNE 50-160/145/A/BAQE/1/7,5/2 T MCE110/C-P	100	60	180	80	240

KDNE 50-160 - 2 POLES - STANDARDISED CENTRIFUGAL ELECTRIC PUMPS WITH INVERTER FOR CIRCULATION SYSTEMS



Pumped liquid temperature range: from -10 °C to +140 °C (MCE/C) - Maximum ambient temperature: +40 °C

= 2900 1/min

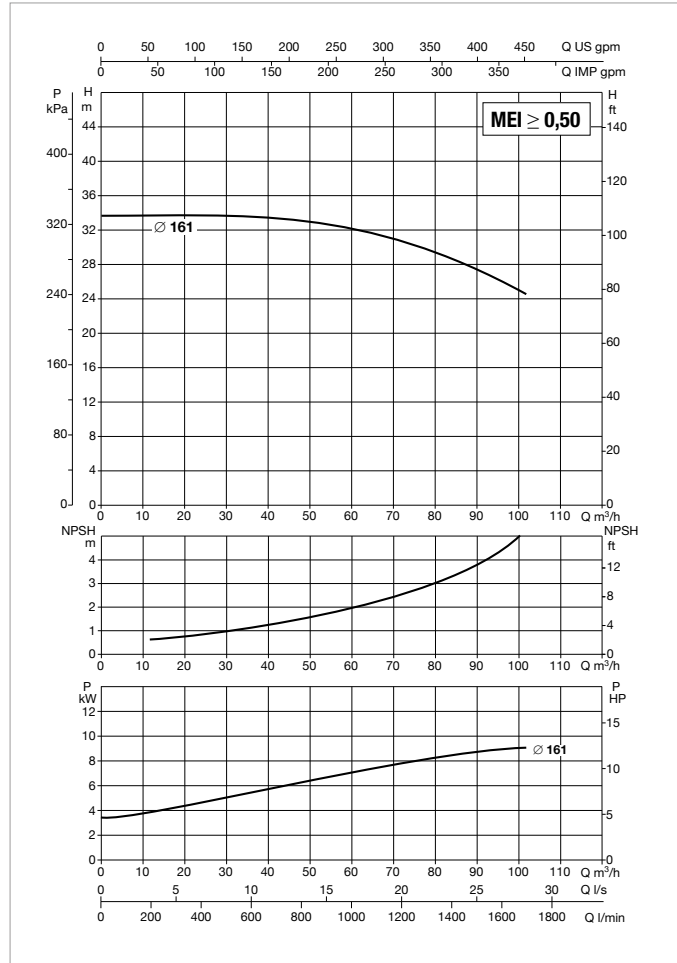
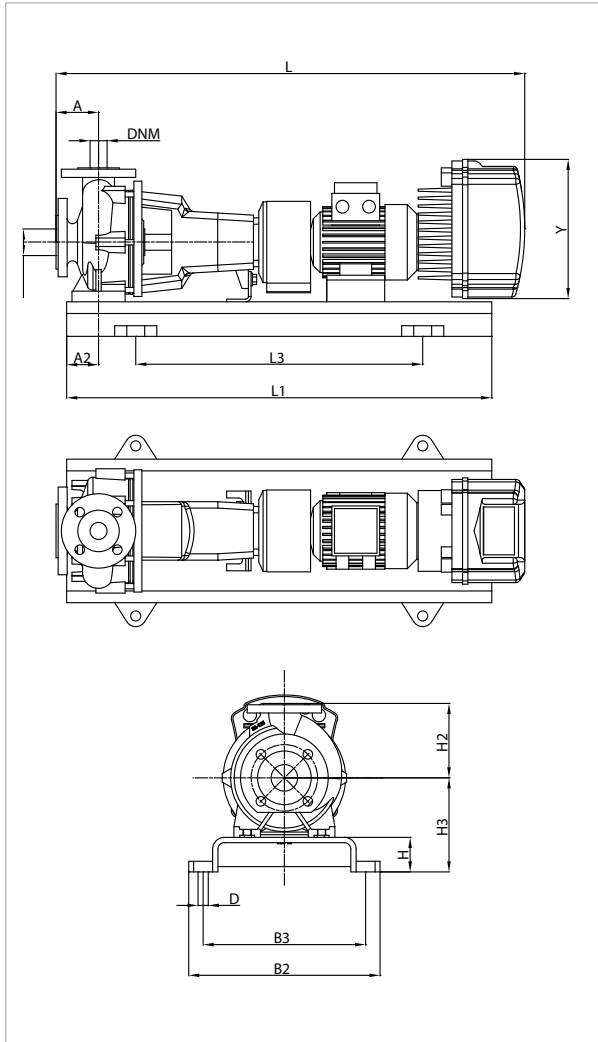

See hydraulic efficiency details on page 241.

The performance curves are based on kinematic viscosity values = 1 mm²/s and density equal to 1000 kg/m³. Curve tolerance according to ISO 9906.

MODEL	MCE MODEL	POWER INPUT 50 Hz	P2 NOMINAL		In A
			kW	HP	
KDNE 50-160/161/A/BAQE/1/11/2 T MCE110/C	MCE110/C	3 x 400 ~V	11	15	25,5

MODEL	A	A2	H2	H	H3	L1	L3	B2	B3	D	Y	FLANGE DIMENSIONS (mm)		STANDARD COUPLING		SPACER COUPLING	
												DNA	DNM	L	WEIGHT kg	L	WEIGHT kg
												KDNE 50-160/161/A/BAQE/1/11/2 T MCE110/C	100	60	180	80	240

KDNE 50-160 - 2 POLES - STANDARDISED CENTRIFUGAL ELECTRIC PUMPS WITH INVERTER FOR PRESSURISATION SYSTEMS



Pumped liquid temperature range: from -10 °C to +80 °C (MCE/P) - Maximum ambient temperature: +40 °C

= 2900 1/min

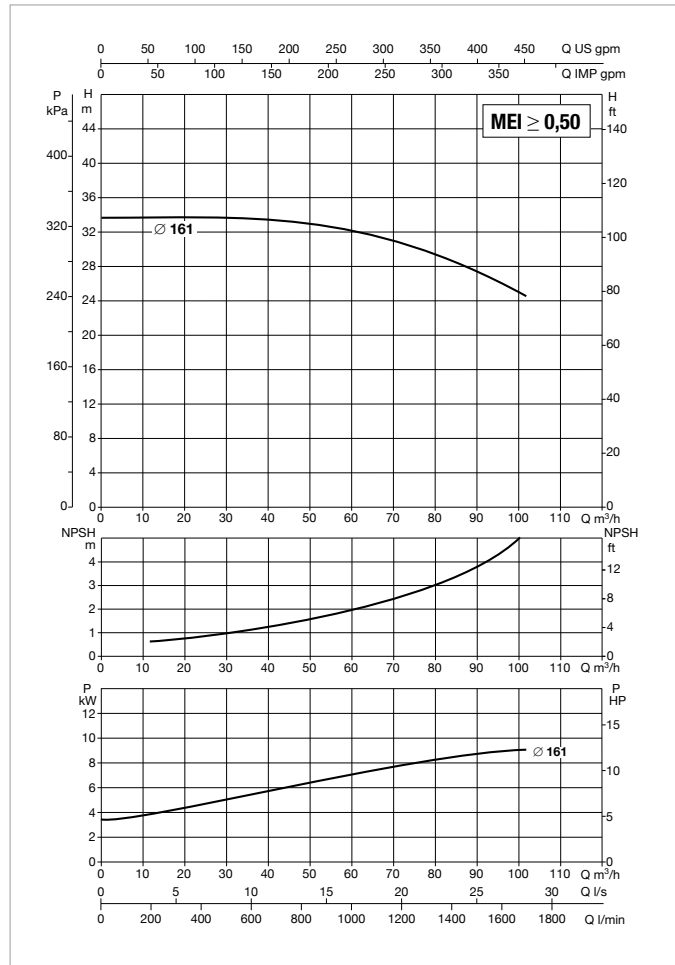
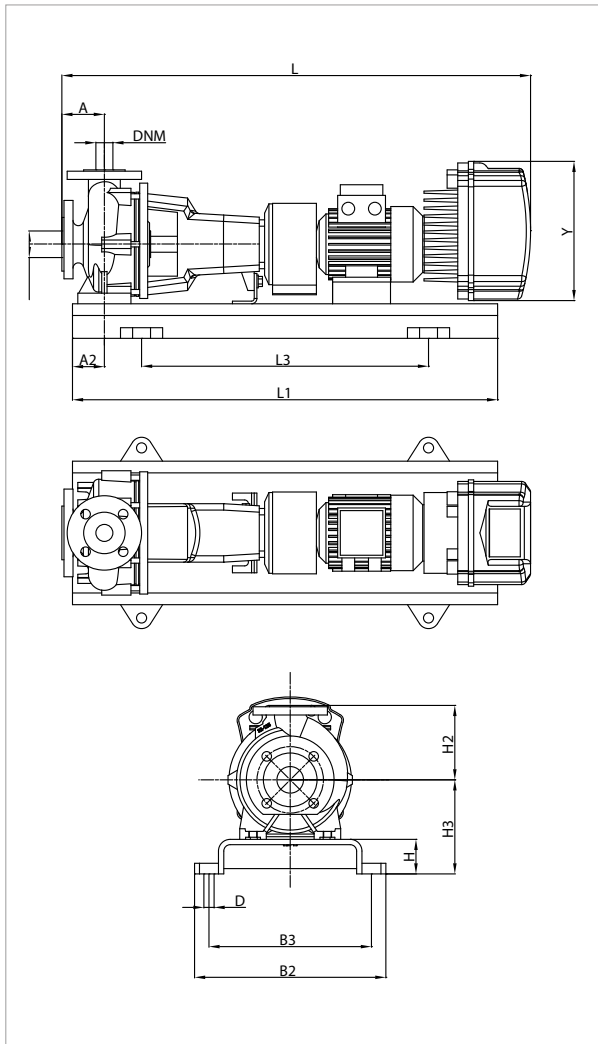

See hydraulic efficiency details on page 241.

The performance curves are based on kinematic viscosity values = 1 mm²/s and density equal to 1000 kg/m³. Curve tolerance according to ISO 9906.

MODEL	MCE MODEL	POWER INPUT 50 Hz	P2 NOMINAL		In A
			kW	HP	
KDNE 50-160/161/A/BAQE/1/11/2 MCE150/P	MCE150/P	3 x 400 ~V	11	15	25,5

MODEL	A	A2	H2	H	H3	L1	L3	B2	B3	D	Y	FLANGE DIMENSIONS (mm)		STANDARD COUPLING		SPACER COUPLING	
												DNA	DNM	L	WEIGHT kg	L	WEIGHT kg
												KDNE 50-160/161/A/BAQE/1/11/2 MCE150/P	100	60	180	80	240

KDNE 50-160 - 2 POLES - STANDARDISED CENTRIFUGAL ELECTRIC PUMPS WITH INVERTER FOR CIRCULATION OR PRESSURISATION SYSTEMS



Pumped liquid temperature range: from -10 °C to +140 °C (MCE/C) - from -10 °C to +80 °C (MCE/P) - Maximum ambient temperature: +40 °C = 2900 1/min

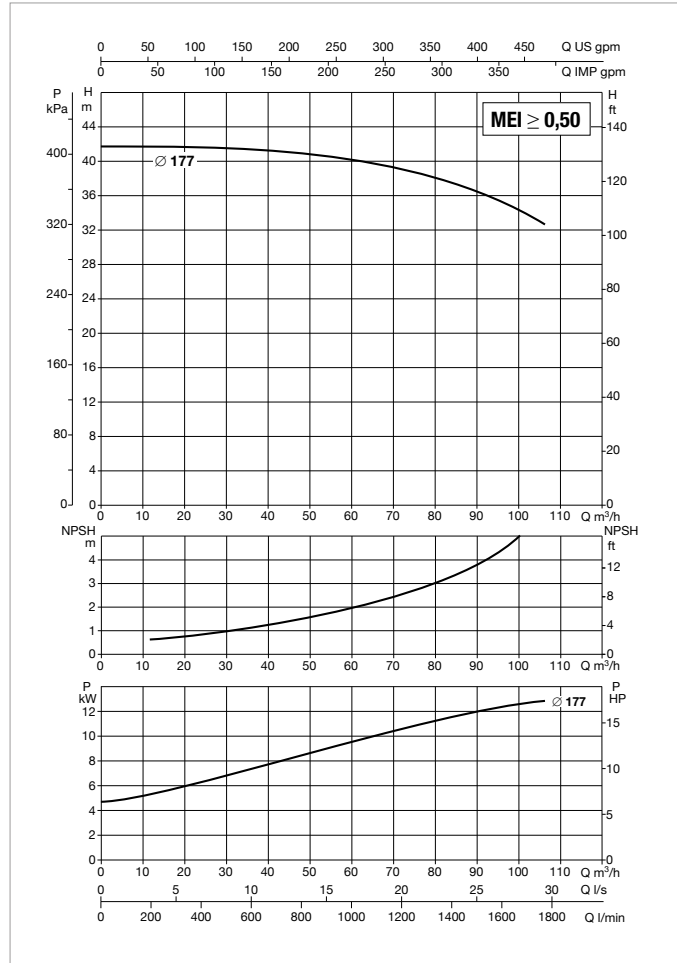
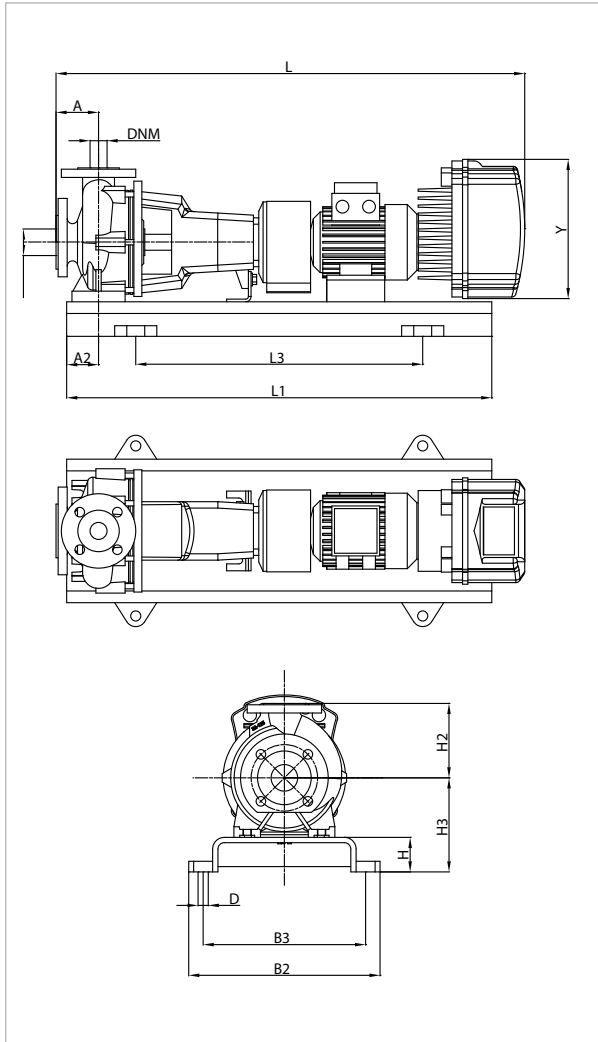

See hydraulic efficiency details on page 241.

The performance curves are based on kinematic viscosity values = 1 mm²/s and density equal to 1000 kg/m³. Curve tolerance according to ISO 9906.

MODEL	MCE MODEL	POWER INPUT 50 Hz	P2 NOMINAL		In A
			kW	HP	
KDNE 50-160/177/BAQE/1/15/2 T MCE150/C-P	MCE150/C - MCE150/P	3 x 400 ~V	15	20	34,0

MODEL	A	A2	H2	H	H3	L1	L3	B2	B3	D	Y	FLANGE DIMENSIONS (mm)		STANDARD COUPLING		SPACER COUPLING	
												DNA	DNM	L	WEIGHT kg	L	WEIGHT kg
												KDNE 50-160/177/BAQE/1/15/2 T MCE150/C-P	100	60	180	80	240

KDNE 50-200 - 2 POLES - STANDARDISED CENTRIFUGAL ELECTRIC PUMPS WITH INVERTER FOR CIRCULATION SYSTEMS



Pumped liquid temperature range: from -10 °C to +140 °C (MCE/C) - Maximum ambient temperature: +40 °C

= 2900 1/min

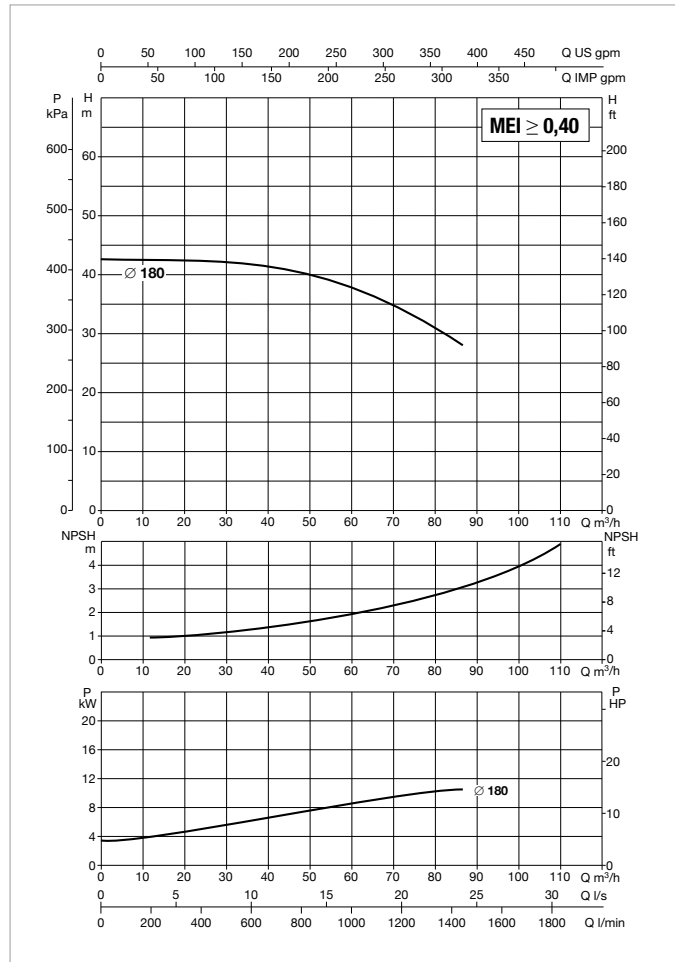
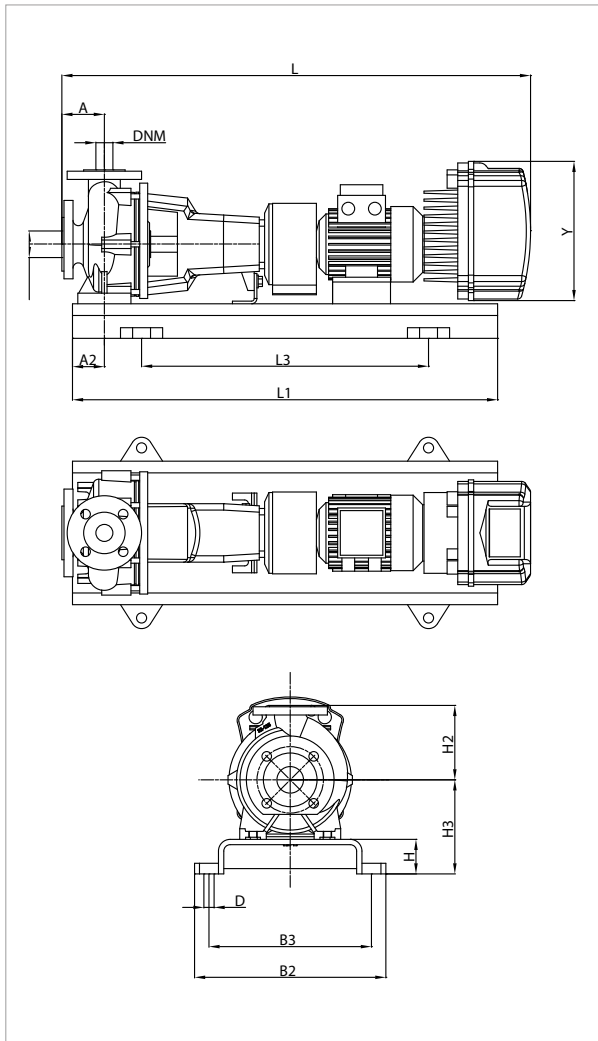

See hydraulic efficiency details on page 241.

The performance curves are based on kinematic viscosity values = 1 mm²/s and density equal to 1000 kg/m³. Curve tolerance according to ISO 9906.

MODEL	MCE MODEL	POWER INPUT 50 Hz	P2 NOMINAL		In A
			kW	HP	
KDNE 50-200/180/A/BAQE/1/11/2 T MCE110/C	MCE110/C	3 x 400 ~V	11	15	25,5

MODEL	A	A2	H2	H	H3	L1	L3	B2	B3	D	Y	FLANGE DIMENSIONS (mm)		STANDARD COUPLING		SPACER COUPLING	
												DNA	DNM	L	WEIGHT kg	L	WEIGHT kg
												KDNE 50-200/180/A/BAQE/1/11/2 T MCE110/C	100	60	200	80	240

KDNE 50-200 - 2 POLES - STANDARDISED CENTRIFUGAL ELECTRIC PUMPS WITH INVERTER FOR PRESSURISATION SYSTEMS



Pumped liquid temperature range: from -10 °C to +80 °C (MCE/P) - Maximum ambient temperature: +40 °C

= 2900 1/min

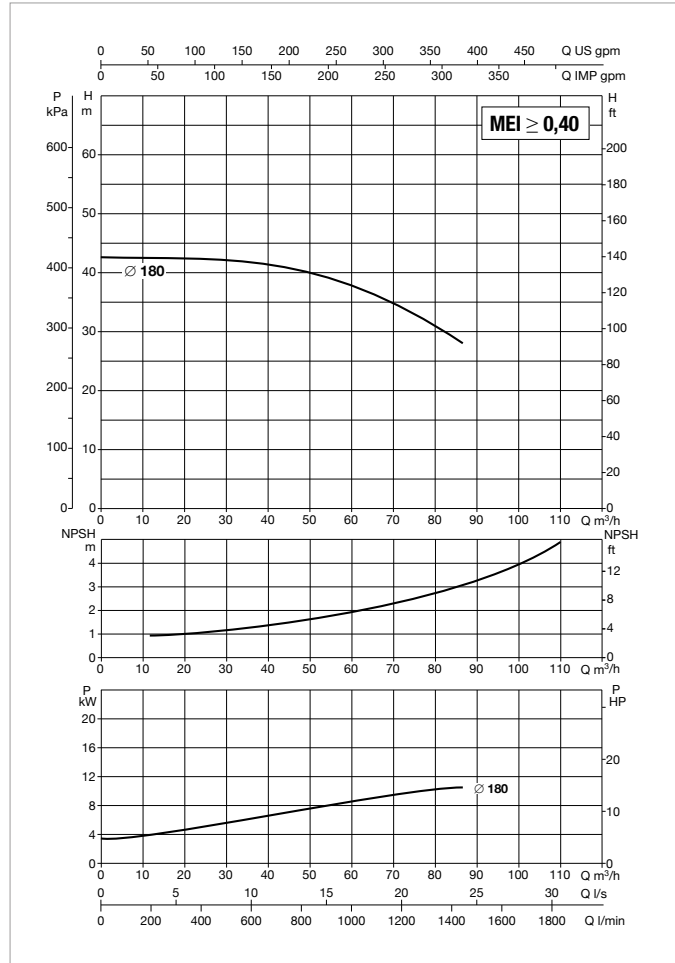
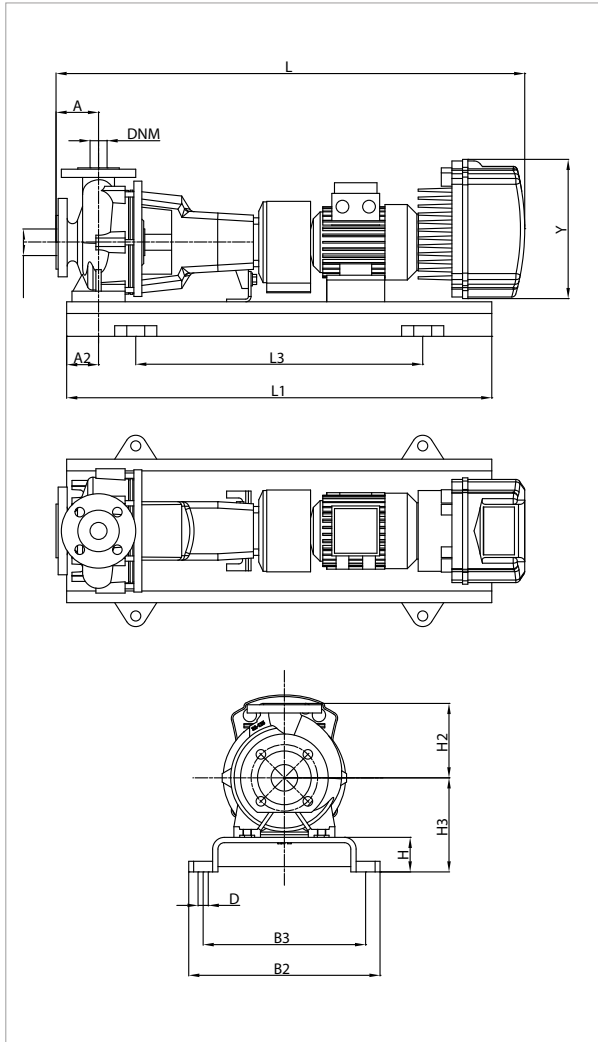

See hydraulic efficiency details on page 241.

The performance curves are based on kinematic viscosity values = 1 mm²/s and density equal to 1000 kg/m³. Curve tolerance according to ISO 9906.

MODEL	MCE MODEL	POWER INPUT 50 Hz	P2 NOMINAL		In A
			kW	HP	
KDNE 50-200/180/A/BAQE/1/11/2 MCE150/P	MCE150/P	3 x 400 ~V	11	15	25,5

MODEL	A	A2	H2	H	H3	L1	L3	B2	B3	D	Y	FLANGE DIMENSIONS (mm)		STANDARD COUPLING		SPACER COUPLING	
												DNA	DNM	L	WEIGHT kg	L	WEIGHT kg
												KDNE 50-200/180/A/BAQE/1/11/2 MCE150/P	100	60	200	80	240

KDNE 50-200 - 2 POLES - STANDARDISED CENTRIFUGAL ELECTRIC PUMPS WITH INVERTER FOR CIRCULATION OR PRESSURISATION SYSTEMS

MCE-C

MCE-P

Pumped liquid temperature range: from -10 °C to +140 °C (MCE/C) - from -10 °C to +80 °C (MCE/P) - Maximum ambient temperature: +40 °C
= 2900 1/min

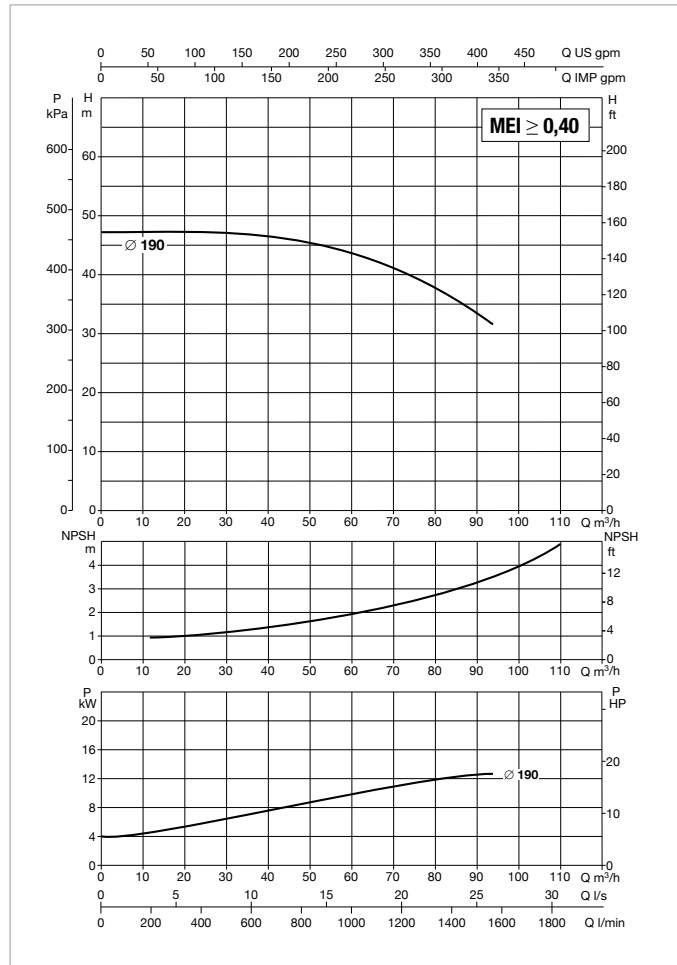
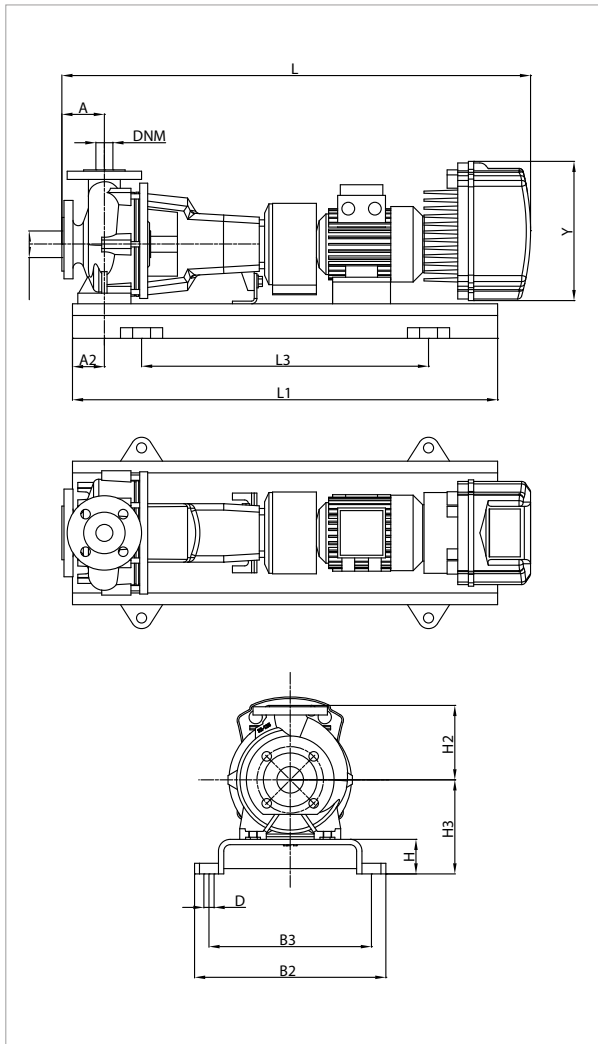

See hydraulic efficiency details on page 241.

The performance curves are based on kinematic viscosity values = 1 mm²/s and density equal to 1000 kg/m³. Curve tolerance according to ISO 9906.

MODEL	MCE MODEL	POWER INPUT 50 Hz	P2 NOMINAL		In A
			kW	HP	
KDNE 50-200/190/A/BAQE/1/15/2 T MCE150/C-P	MCE150/C - MCE150/P	3 x 400 ~V	15	20	34,0

MODEL	A	A2	H2	H	H3	L1	L3	B2	B3	D	Y	FLANGE DIMENSIONS (mm)		STANDARD COUPLING		SPACER COUPLING	
												DNA	DNM	L	WEIGHT kg	L	WEIGHT kg
KDNE 50-200/190/A/BAQE/1/15/2 T MCE150/C-P	100	60	200	80	240	1120	740	490	440	24	426	65	50	1339	293	1439	298

KDNE 65-125 - 2 POLES - STANDARDISED CENTRIFUGAL ELECTRIC PUMPS WITH INVERTER FOR CIRCULATION SYSTEMS



Pumped liquid temperature range: from -10 °C to +140 °C (MCE/C) - Maximum ambient temperature: +40 °C

= 2900 1/min

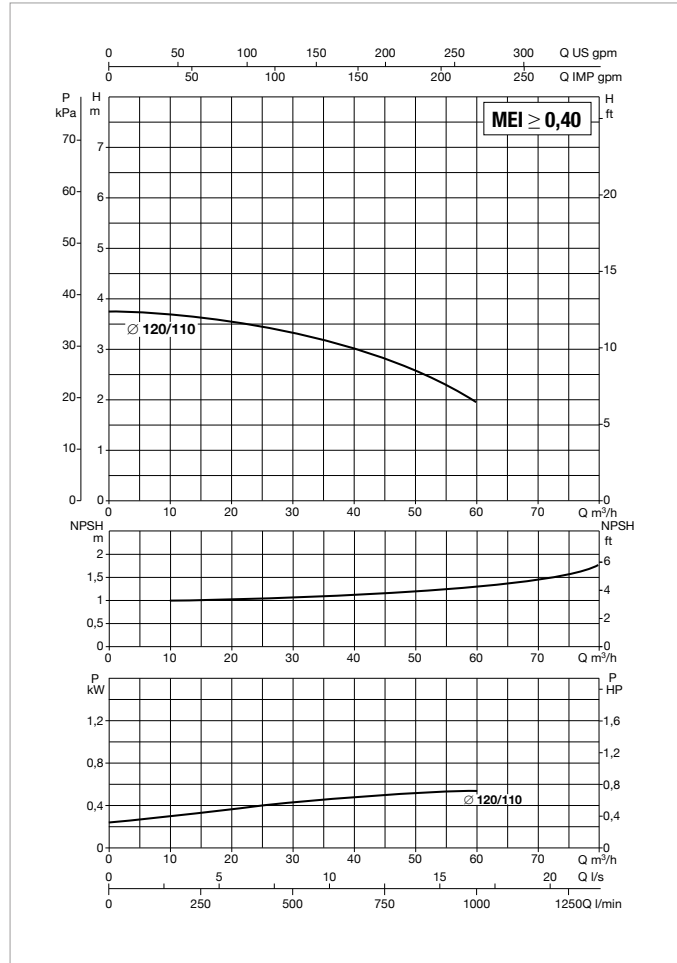
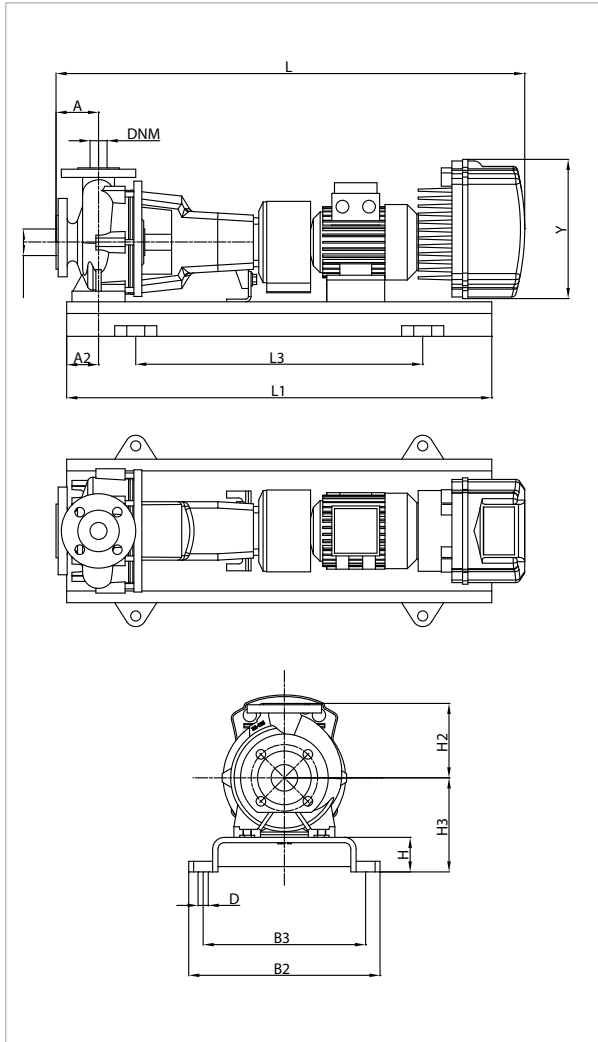

See hydraulic efficiency details on page 241.

The performance curves are based on kinematic viscosity values = 1 mm²/s and density equal to 1000 kg/m³. Curve tolerance according to ISO 9906.

MODEL	MCE MODEL	POWER INPUT 50 Hz	P2 NOMINAL		In A
			kW	HP	
KDNE 65-125/120-110/A/BAQE/1/5,5/2 T MCE55/C	MCE55/C	3 x 400 ~V	5,5	7,5	13,1

MODEL	A	A2	H2	H	H3	L1	L3	B2	B3	D	Y	FLANGE DIMENSIONS (mm)		STANDARD COUPLING		SPACER COUPLING	
												DNA	DNM	L	WEIGHT kg	L	WEIGHT kg
												KDNE 65-125/120-110/A/BAQE/1/5,5/2 T MCE55/C	100	60	180	80	240

KDNE 65-125 - 2 POLES - STANDARDISED CENTRIFUGAL ELECTRIC PUMPS WITH INVERTER FOR CIRCULATION OR PRESSURISATION SYSTEMS

MCE-C

MCE-P

Pumped liquid temperature range: from -10 °C to +140 °C (MCE/C) - from -10 °C to +80 °C (MCE/P) - Maximum ambient temperature: +40 °C
= 2900 1/min

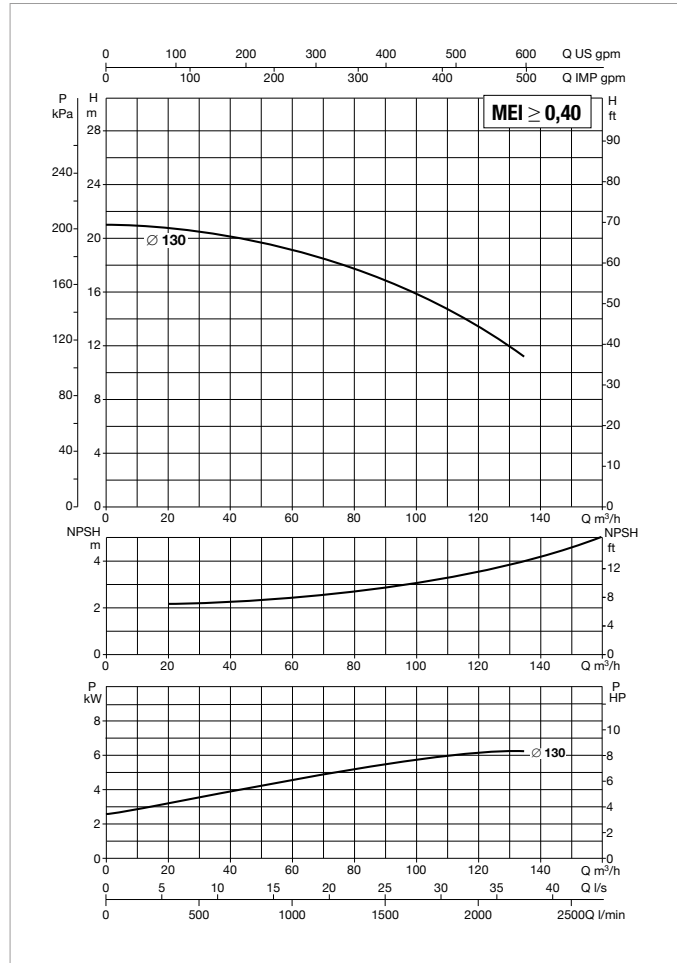
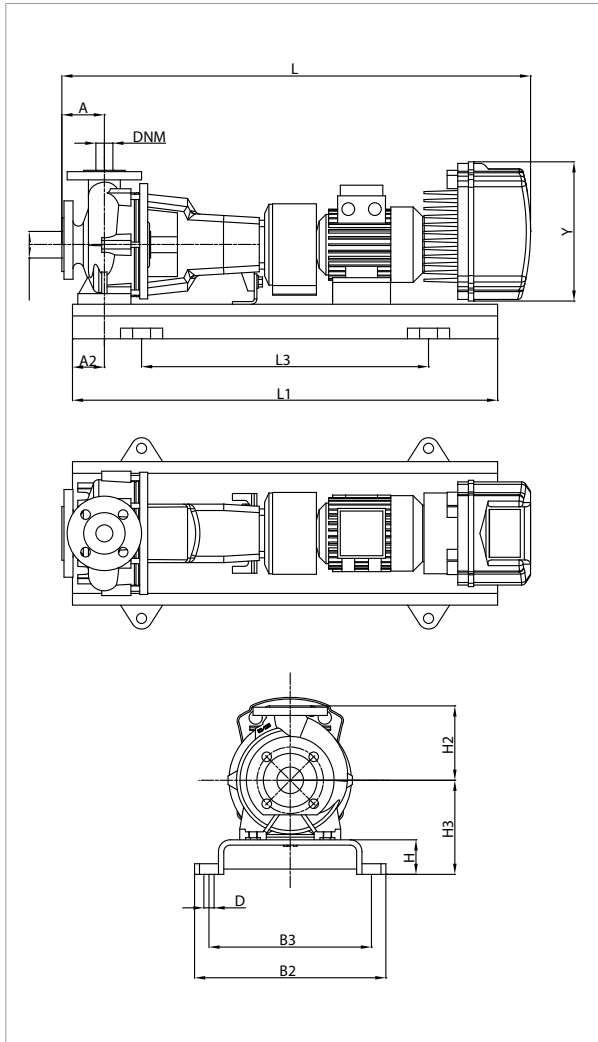

See hydraulic efficiency details on page 241.

The performance curves are based on kinematic viscosity values = 1 mm²/s and density equal to 1000 kg/m³. Curve tolerance according to ISO 9906.

MODEL	MCE MODEL	POWER INPUT 50 Hz	P2 NOMINAL		In A
			kW	HP	
KDNE 65-125/130/A/BAQE/1/7,5/2 T MCE110/C-P	MCE110/C - MCE110/P	3 x 400 ~V	7,5	10	17,6

MODEL	A	A2	H2	H	H3	L1	L3	B2	B3	D	Y	FLANGE DIMENSIONS (mm)		STANDARD COUPLING		SPACER COUPLING	
												DNA	DNM	L	WEIGHT kg	L	WEIGHT kg
												KDNE 65-125/130/A/BAQE/1/7,5/2 T MCE110/C-P	100	60	180	80	240

KDNE 65-125 - 2 POLES - STANDARDISED CENTRIFUGAL ELECTRIC PUMPS WITH INVERTER FOR CIRCULATION SYSTEMS



Pumped liquid temperature range: from -10 °C to +140 °C (MCE/C) - Maximum ambient temperature: +40 °C

= 2900 1/min

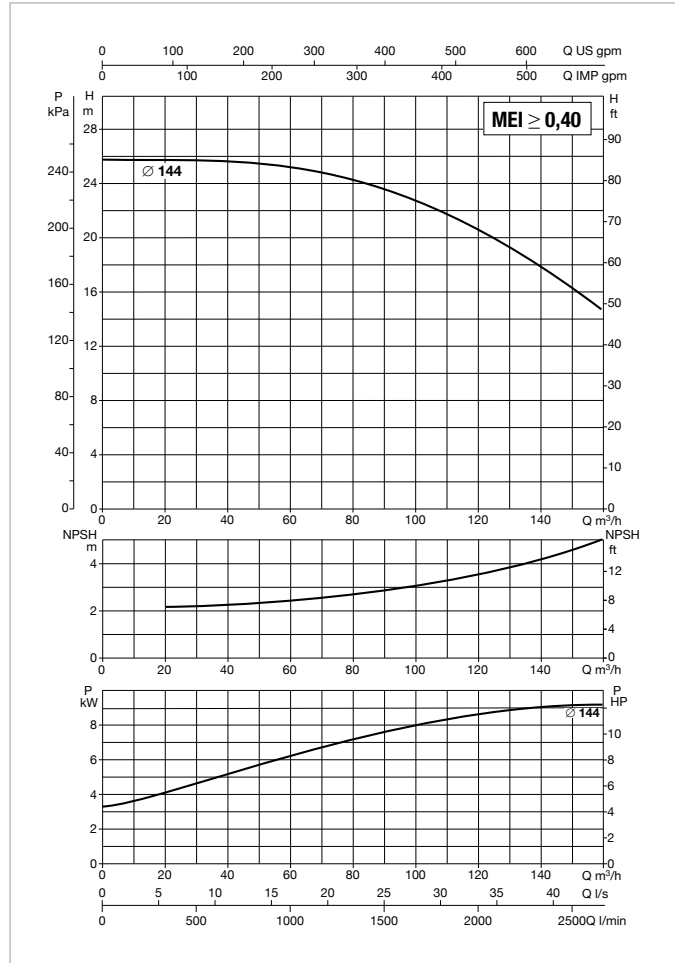
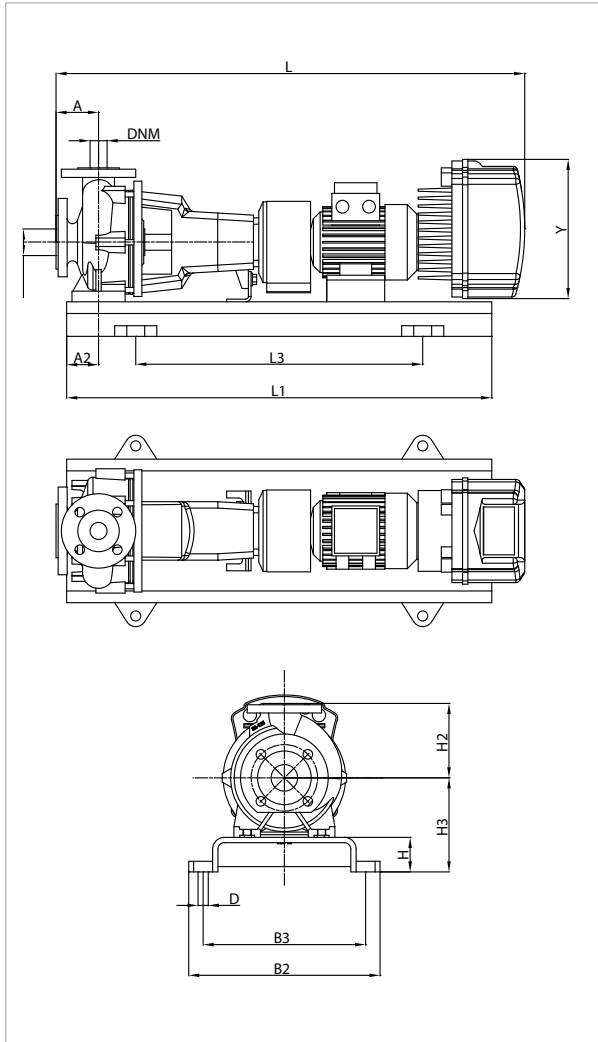

See hydraulic efficiency details on page 241.

The performance curves are based on kinematic viscosity values = 1 mm²/s and density equal to 1000 kg/m³. Curve tolerance according to ISO 9906.

MODEL	MCE MODEL	POWER INPUT 50 Hz	P2 NOMINAL		In A
			kW	HP	
KDNE 65-125/144/A/BAQE/1/11/2 T MCE110/C	MCE110/C	3 x 400 ~V	11	15	25,5

MODEL	A	A2	H2	H	H3	L1	L3	B2	B3	D	Y	FLANGE DIMENSIONS (mm)		STANDARD COUPLING		SPACER COUPLING	
												DNA	DNM	L	WEIGHT kg	L	WEIGHT kg
												KDNE 65-125/144/A/BAQE/1/11/2 T MCE110/C	100	60	180	80	240

KDNE 65-125 - 2 POLES - STANDARDISED CENTRIFUGAL ELECTRIC PUMPS WITH INVERTER FOR PRESSURISATION SYSTEMS



Pumped liquid temperature range: from -10 °C to +80 °C (MCE/P) - Maximum ambient temperature: +40 °C

= 2900 1/min

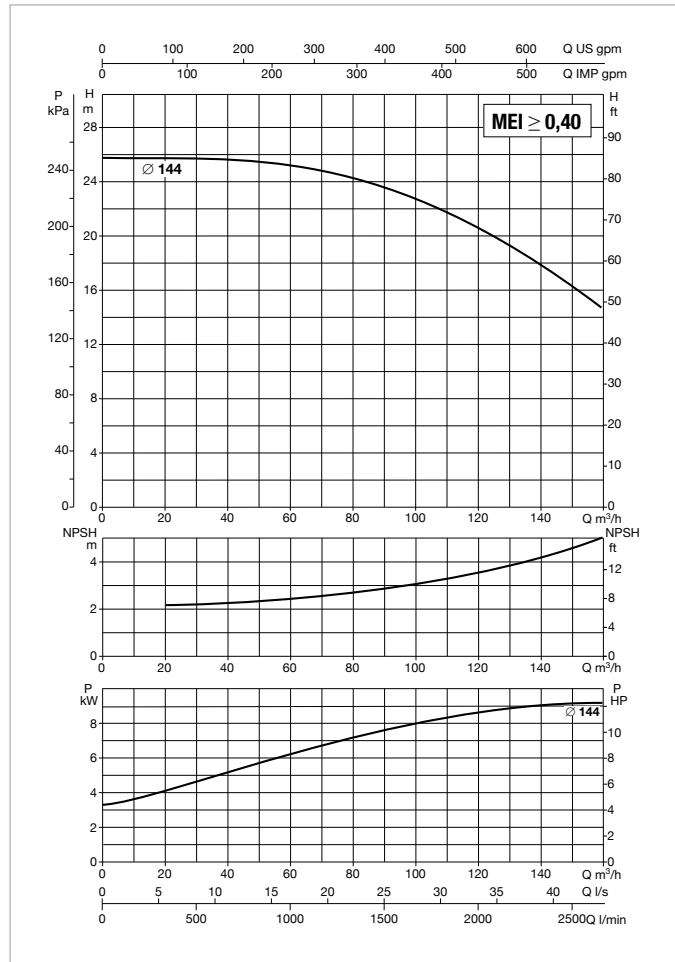
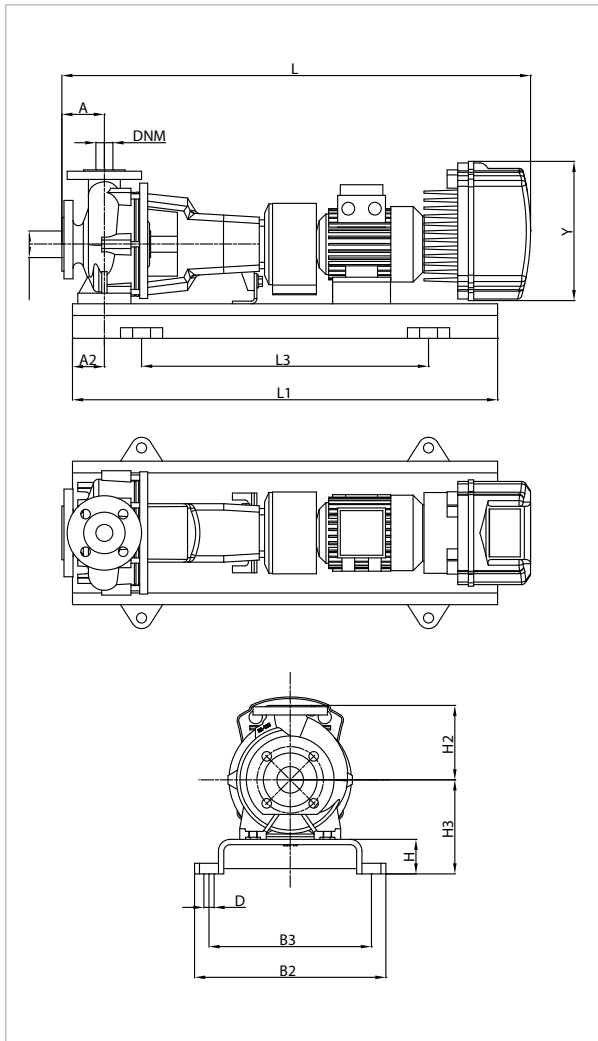

See hydraulic efficiency details on page 241.

The performance curves are based on kinematic viscosity values = 1 mm²/s and density equal to 1000 kg/m³. Curve tolerance according to ISO 9906.

MODEL	MCE MODEL	POWER INPUT 50 Hz	P2 NOMINAL		In A
			kW	HP	
KDNE 65-125/144/A/BAQE/1/11/2 MCE150/P	MCE150/P	3 x 400 ~V	11	15	25,5

MODEL	A	A2	H2	H	H3	L1	L3	B2	B3	D	Y	FLANGE DIMENSIONS (mm)		STANDARD COUPLING		SPACER COUPLING	
												DNA	DNM	L	WEIGHT kg	L	WEIGHT kg
												KDNE 65-125/144/A/BAQE/1/11/2 MCE150/P	100	60	180	80	240

KDNE 65-160 - 2 POLES - STANDARDISED CENTRIFUGAL ELECTRIC PUMPS WITH INVERTER FOR CIRCULATION OR PRESSURISATION SYSTEMS



Pumped liquid temperature range: from -10 °C to +140 °C (MCE/C) - from -10 °C to +80 °C (MCE/P) - Maximum ambient temperature: +40 °C = 2900 1/min

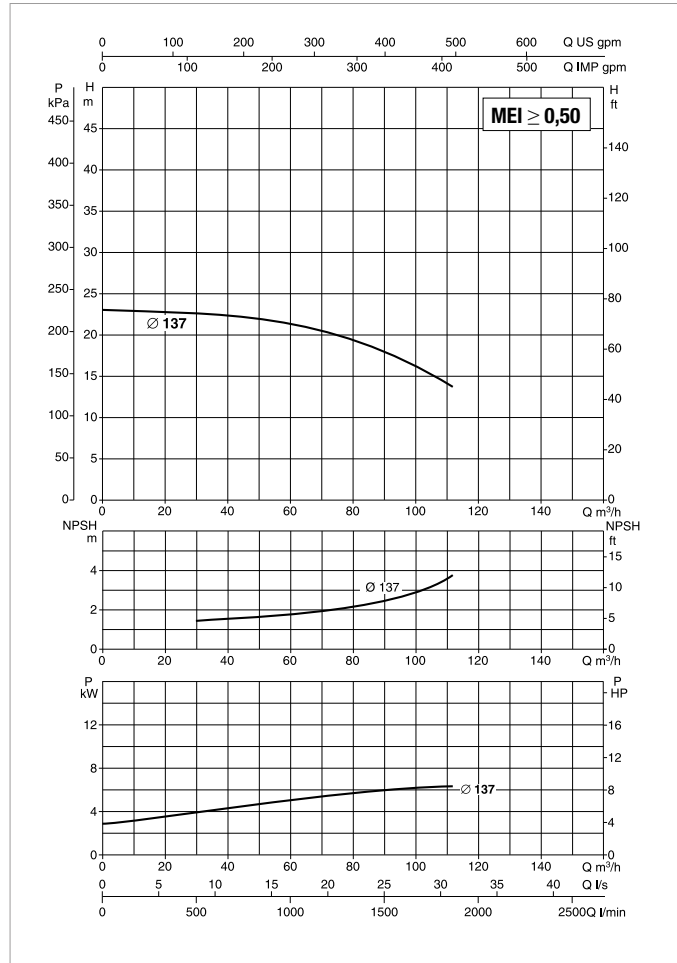
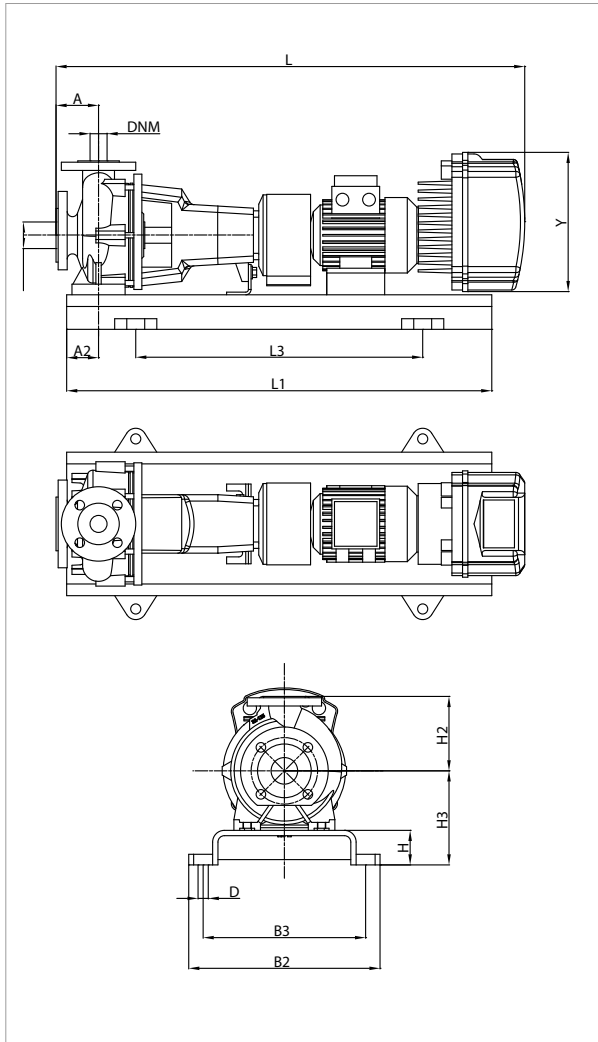

See hydraulic efficiency details on page 241.

The performance curves are based on kinematic viscosity values = 1 mm²/s and density equal to 1000 kg/m³. Curve tolerance according to ISO 9906.

MODEL	MCE MODEL	POWER INPUT 50 Hz	P2 NOMINAL		In A
			kW	HP	
KDNE 65-160/137/A/BAQE/1/7,5/2 T MCE110/C-P	MCE110/C - MCE110/P	3 x 400 ~V	7,5	10	17,6

MODEL	A	A2	H2	H	H3	L1	L3	B2	B3	D	Y	FLANGE DIMENSIONS (mm)		STANDARD COUPLING		SPACER COUPLING	
												DNA	DNM	L	WEIGHT kg	L	WEIGHT kg
												KDNE 65-160/137/A/BAQE/1/7,5/2 T MCE110/C-P	100	60	200	80	240

KDNE 65-160 - 2 POLES - STANDARDISED CENTRIFUGAL ELECTRIC PUMPS WITH INVERTER FOR CIRCULATION SYSTEMS



Pumped liquid temperature range: from -10 °C to +140 °C (MCE/C) - Maximum ambient temperature: +40 °C

= 2900 1/min

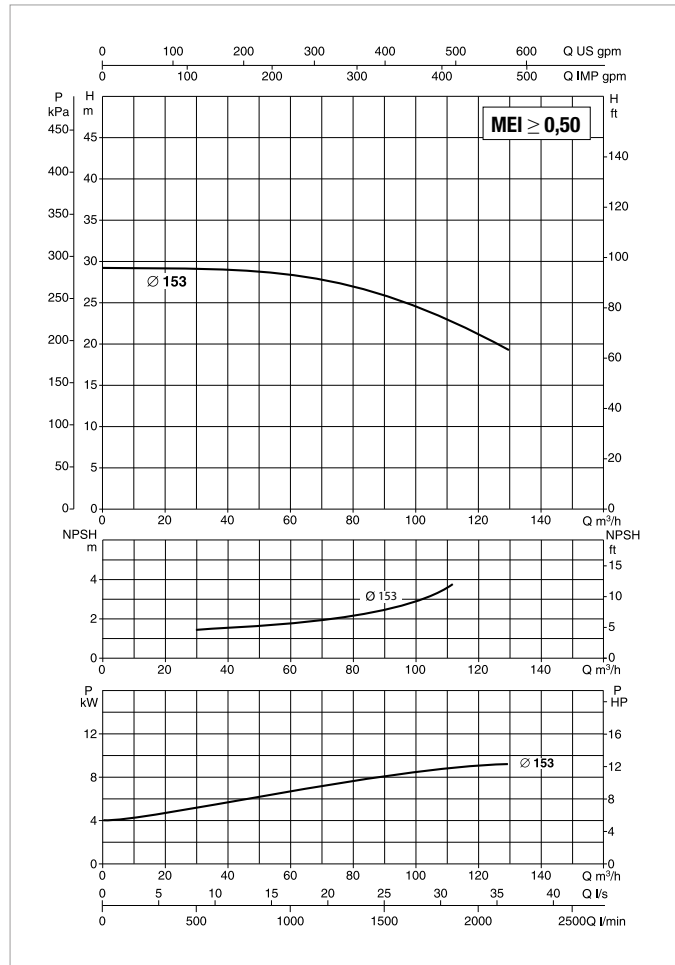
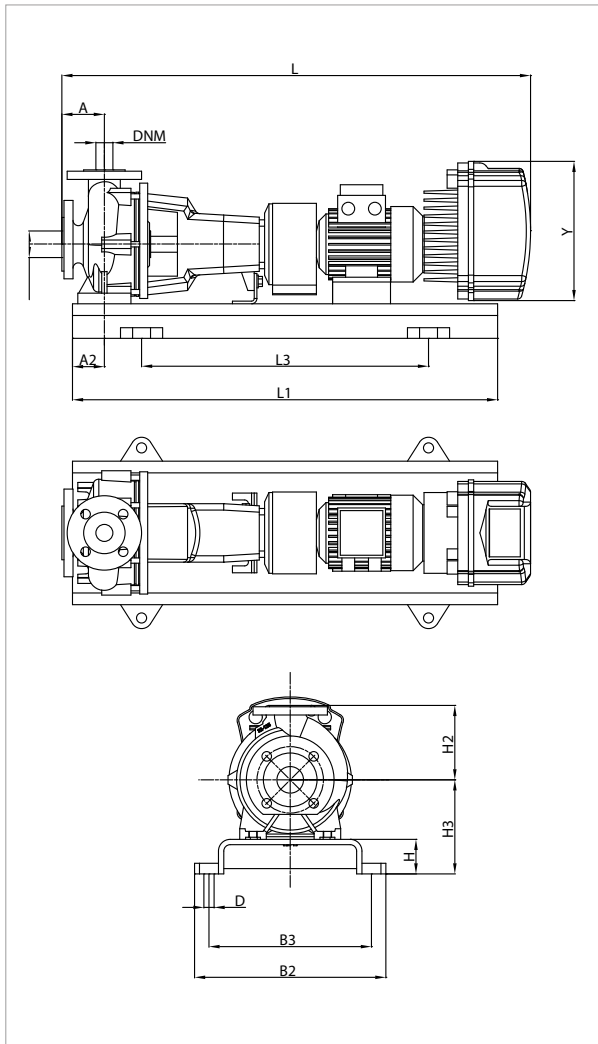

See hydraulic efficiency details on page 241.

The performance curves are based on kinematic viscosity values = 1 mm²/s and density equal to 1000 kg/m³. Curve tolerance according to ISO 9906.

MODEL	MCE MODEL	POWER INPUT 50 Hz	P2 NOMINAL		In A
			kW	HP	
KDNE 65-160/153/A/BAQE/1/11/2 T MCE110/C	MCE110/C	3 x 400 ~V	11	15	25,5

MODEL	A	A2	H2	H	H3	L1	L3	B2	B3	D	Y	FLANGE DIMENSIONS (mm)		STANDARD COUPLING		SPACER COUPLING	
												DNA	DNM	L	WEIGHT kg	L	WEIGHT kg
												KDNE 65-160/153/A/BAQE/1/11/2 T MCE110/C	100	60	200	80	240

KDNE 65-160 - 2 POLES - STANDARDISED CENTRIFUGAL ELECTRIC PUMPS WITH INVERTER FOR PRESSURISATION SYSTEMS



Pumped liquid temperature range: from -10 °C to +80 °C (MCE/P) - Maximum ambient temperature: +40 °C

= 2900 1/min

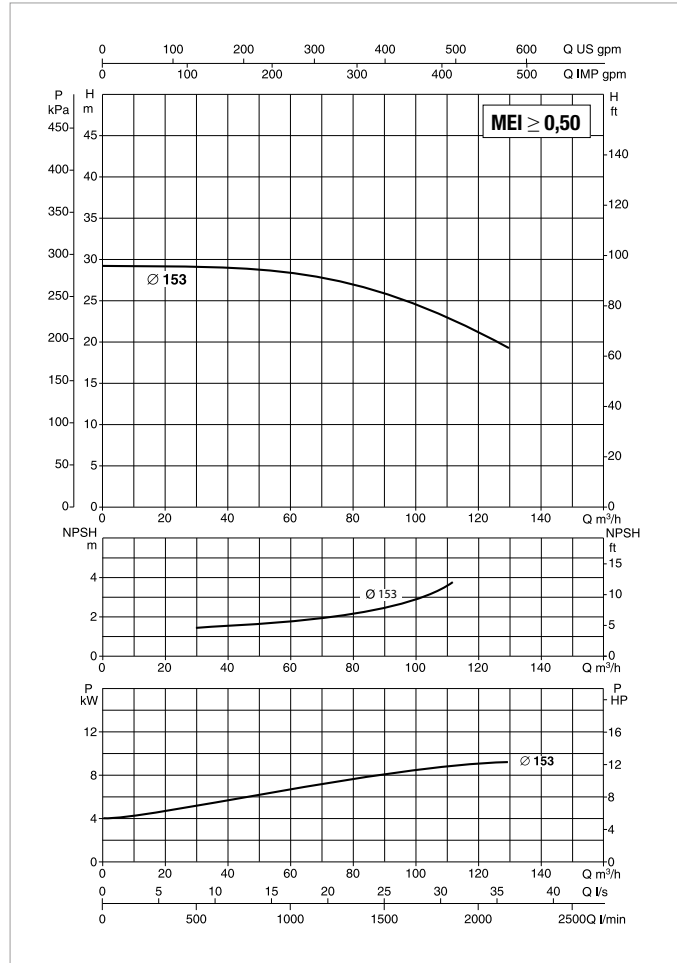
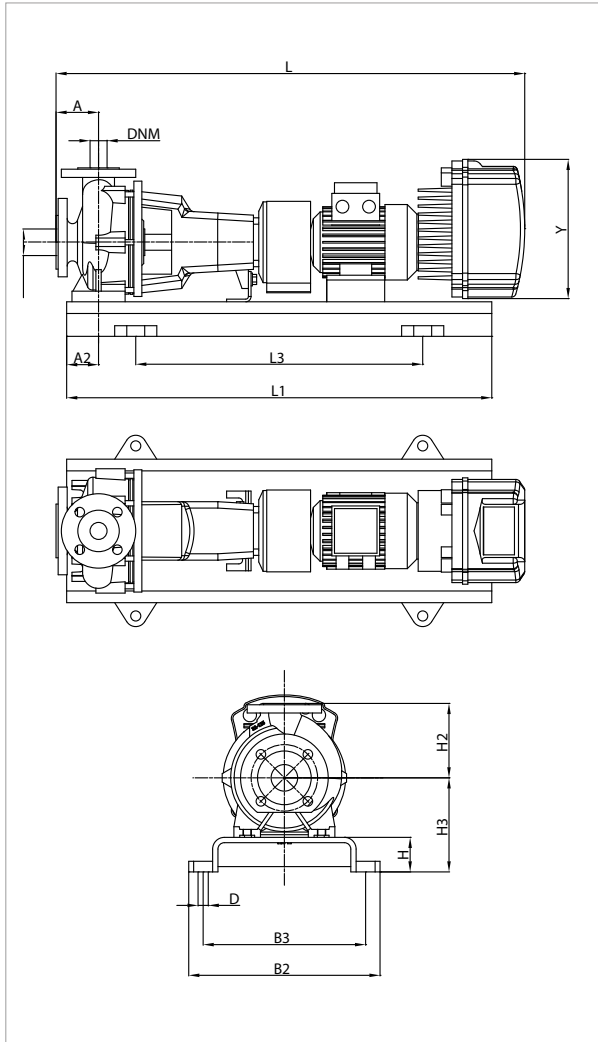

See hydraulic efficiency details on page 241.

The performance curves are based on kinematic viscosity values = 1 mm²/s and density equal to 1000 kg/m³. Curve tolerance according to ISO 9906.

MODEL	MCE MODEL	POWER INPUT 50 Hz	P2 NOMINAL		In A
			kW	HP	
KDNE 65-160/153/A/BAQE/1/11/2 MCE150/P	MCE150/P	3 x 400 ~V	11	15	25,5

MODEL	A	A2	H2	H	H3	L1	L3	B2	B3	D	Y	FLANGE DIMENSIONS (mm)		STANDARD COUPLING		SPACER COUPLING	
												DNA	DNM	L	WEIGHT kg	L	WEIGHT kg
KDNE 65-160/153/A/BAQE/1/11/2 MCE150/P	100	60	200	80	240	1120	740	490	440	24	426	80	65	1339	196	1439	201

KDNE 65-160 - 2 POLES - STANDARDISED CENTRIFUGAL ELECTRIC PUMPS WITH INVERTER FOR CIRCULATION OR PRESSURISATION SYSTEMS

MCE-C

MCE-P

Pumped liquid temperature range: from -10 °C to +140 °C (MCE/C) - from -10 °C to +80 °C (MCE/P) - Maximum ambient temperature: +40 °C
= 2900 1/min

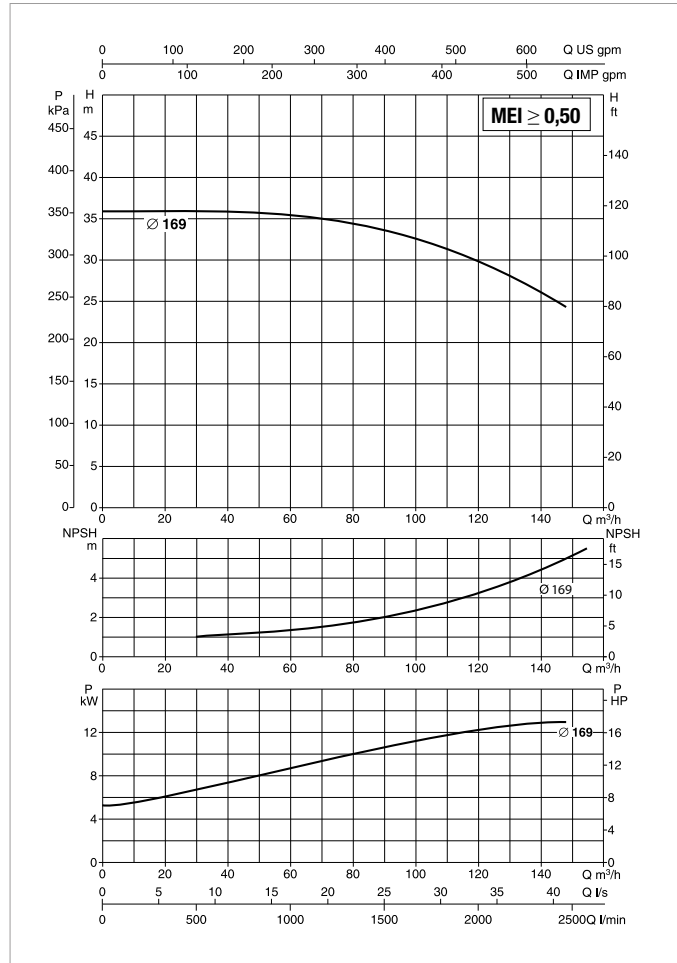
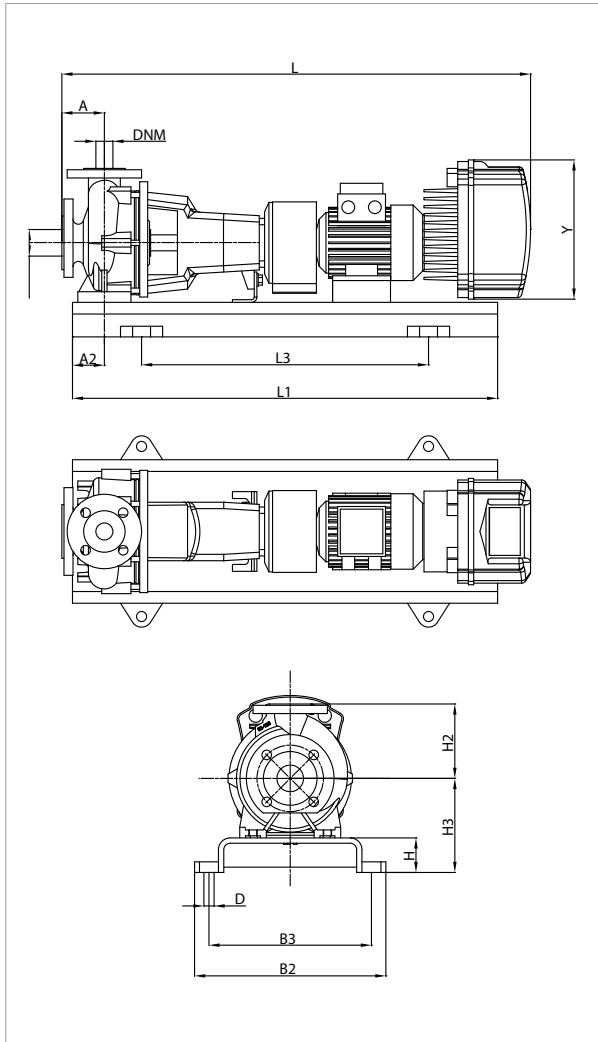

See hydraulic efficiency details on page 241.

The performance curves are based on kinematic viscosity values = 1 mm²/s and density equal to 1000 kg/m³. Curve tolerance according to ISO 9906.

MODEL	MCE MODEL	POWER INPUT 50 Hz	P2 NOMINAL		In A
			kW	HP	
KDNE 65-160/169/A/BAQE/1/15/2 T MCE150/C-P	MCE150/C - MCE150/P	3 x 400 ~V	15	20	34,0

MODEL	A	A2	H2	H	H3	L1	L3	B2	B3	D	Y	FLANGE DIMENSIONS (mm)		STANDARD COUPLING		SPACER COUPLING	
												DNA	DNM	L	WEIGHT kg	L	WEIGHT kg
												KDNE 65-160/169/A/BAQE/1/15/2 T MCE150/C-P	100	60	200	80	240

KDNE 65-200 - 2 POLES - STANDARDISED CENTRIFUGAL ELECTRIC PUMPS WITH INVERTER FOR CIRCULATION OR PRESSURISATION SYSTEMS

MCE-C

MCE-P

Pumped liquid temperature range: from -10 °C to +140 °C (MCE/C) - from -10 °C to +80 °C (MCE/P) - Maximum ambient temperature: +40 °C = 2900 l/min

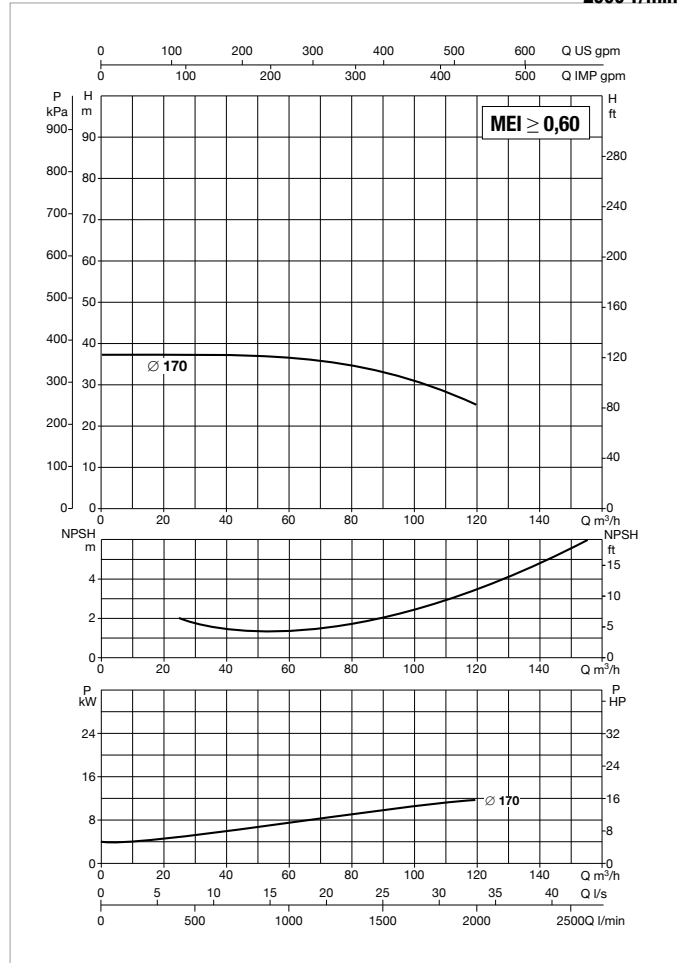
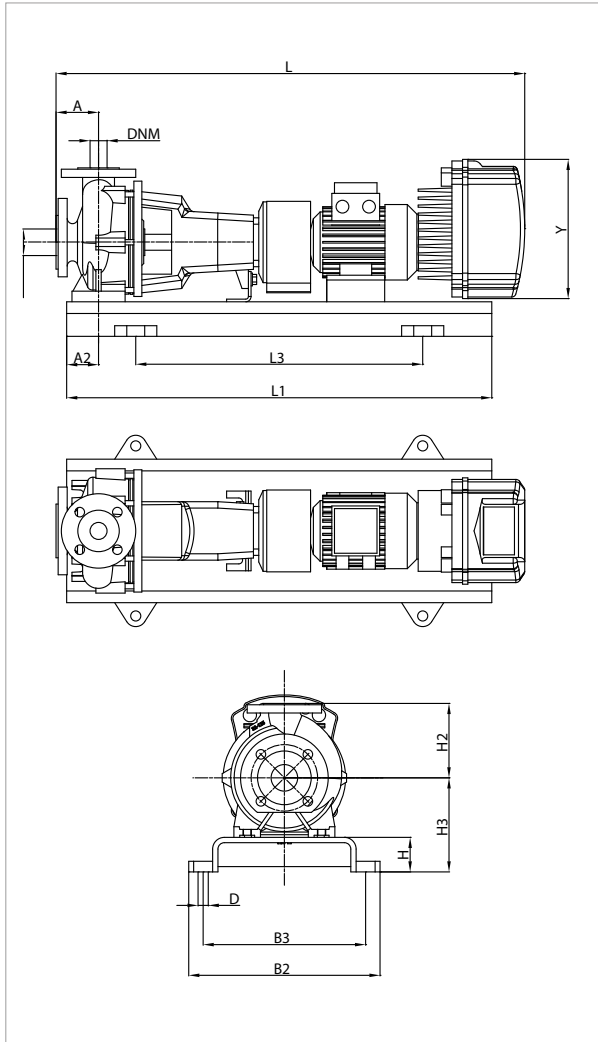

See hydraulic efficiency details on page 241.

The performance curves are based on kinematic viscosity values = 1 mm²/s and density equal to 1000 kg/m³. Curve tolerance according to ISO 9906.

MODEL	MCE MODEL	POWER INPUT 50 Hz	P2 NOMINAL		In A
			kW	HP	
KDNE 65-200/170/A/BAQE/1/15/2 T MCE150/C-P	MCE150/C - MCE150/P	3 x 400 ~V	15	20	34,0

MODEL	A	A2	H2	H	H3	L1	L3	B2	B3	D	Y	FLANGE DIMENSIONS (mm)		STANDARD COUPLING		SPACER COUPLING	
												DNA	DNM	L	WEIGHT kg	L	WEIGHT kg
												KDNE 65-200/170/A/BAQE/1/15/2 T MCE150/C-P	100	75	225	80	260

KDNE 80-160 - 2 POLES - STANDARDISED CENTRIFUGAL ELECTRIC PUMPS WITH INVERTER FOR CIRCULATION OR PRESSURISATION SYSTEMS

MCE-C

MCE-P

Pumped liquid temperature range: from -10 °C to +140 °C (MCE/C) - from -10 °C to +80 °C (MCE/P) - Maximum ambient temperature: +40 °C
= 2900 1/min

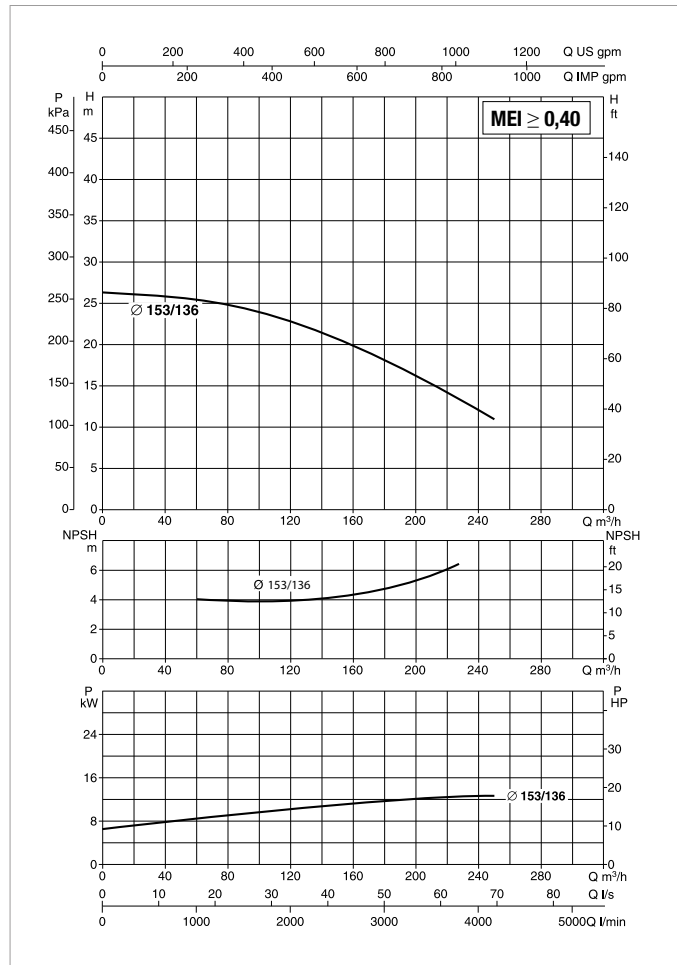
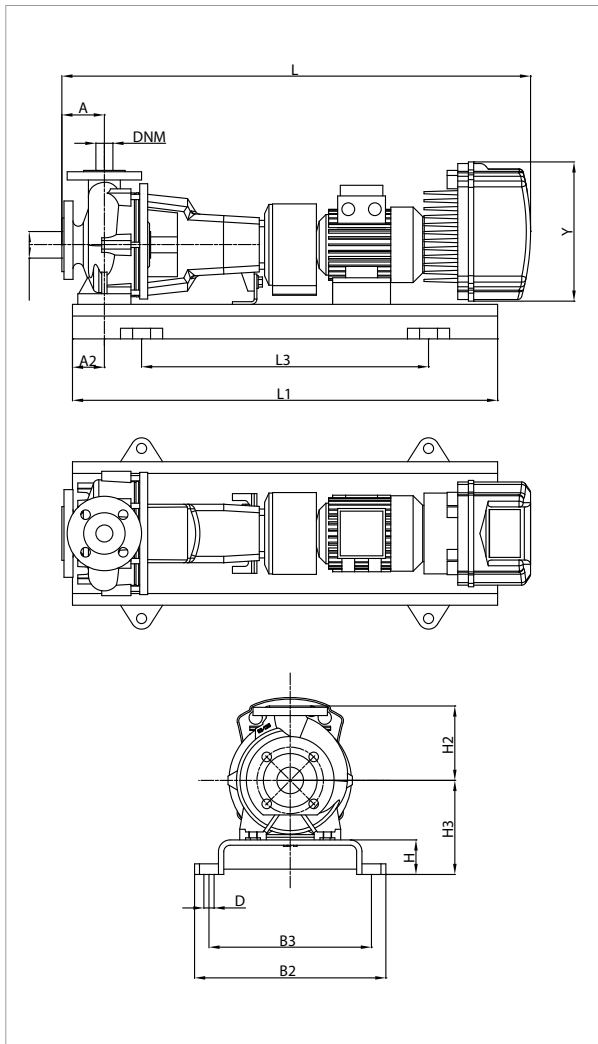

See hydraulic efficiency details on page 241.

The performance curves are based on kinematic viscosity values = 1 mm²/s and density equal to 1000 kg/m³. Curve tolerance according to ISO 9906.

MODEL	MCE MODEL	POWER INPUT 50 Hz	P2 NOMINAL		In A
			kW	HP	
KDNE 80-160/153-136/A/BAQE/1/15/2 T MCE150/C-P	MCE150/C - MCE150/P	3 x 400 ~V	15	20	34,0

MODEL	A	A2	H2	H	H3	L1	L3	B2	B3	D	Y	FLANGE DIMENSIONS (mm)		STANDARD COUPLING		SPACER COUPLING	
												DNA	DNM	L	WEIGHT kg	L	WEIGHT kg
												KDNE 80-160/153-136/A/BAQE/1/15/2 T MCE150/C-P	100	75	225	80	260

VERTICAL AXIS MULTISTAGE CENTRIFUGAL PUMPS WITH MCE/P INVERTER**TECHNICAL DATA****Operating range:**

from 1 to 12 m³/h with head up to 110 metres.

Pumped liquid: clean, free of solids and abrasives, non-viscous, non-crystallised and chemically neutral, with properties similar to water.

Liquid temperature range:

from 0 °C to +35 °C for domestic use

(EN 60335-2-41 safety standards).

from 0 °C to +40 °C for other uses.

Maximum ambient temperature: +40 °C.

Maximum operating pressure: 12 bar (1200 kPa).

Installation: fixed, vertical position.

APPLICATIONS

Vertical multistage centrifugal pump suitable for medium to large user water systems. Recommended for pressurisation units, boiler supply, hot water and cooling water circulation, fire fighting and washing systems, drinking water supply and filling of pressure vessels, sprinkler and watering systems and water purification systems.

ADVANTAGES OF USE

Operating pressure stability – **Excellent energy saving** (up to 60 %) – Reduced hammering effects – Reduced space requirements – Less maintenance – Reduced pump wear – Less power factor correction required – Less water consumption – Integrated protections.

CONSTRUCTION FEATURES OF THE PUMP

Technopolymer delivery and suction bodies with IN-LINE suction and delivery ports with threaded metal insert.

Impellers, diffuser bodies and diffusers in technopolymer, fully rust-proof.

AISI 304 stainless steel pump liner, adjustment rings and seal disc. Carbon/ceramic mechanical seal, fitted on the AISI 303 stainless-steel drive shaft extension.

CONSTRUCTION FEATURES OF THE MOTOR

Shaft with rotor running on permanently lubricated ball bearings, oversized to ensure low noise and durability.

Construction according to CEI 2-3.

Controlled by MCE inverter.

Protection class: IP 55

Insulation class: F.

Standard single-phase voltage: 1x230 V / 50-60 Hz

Special version on request: three-phase 3x400 V / 50 Hz, or three-phase 3x460 V / 60 Hz

Standard three-phase voltage: 3x400 V / 50 Hz

Special version on request: 3x460 V / 60 Hz

MCE/P INVERTER



CONSTRUCTION FEATURES OF THE ELECTRONICS: MCE/P INVERTER

The inverter continuously adjusts the rotation speed of the electric pump, keeping the pressure constant, even when the flow rate varies. The other electric pumps, also with variable speed, are activated in cascade after the first one has reached maximum speed. Through modulation, they compensate the pressure fluctuations of the system.

For every operating cycle, it is possible to switch the restart to a different pump, therefore ensuring even use of all electric pumps.

It is possible to set operation times for each individual pump, switching to another pump after such set times.

The "SP" pressure can be adjusted by the user using the "+" and "-" keys found on the MCE/P (as a rule, all the pumps are set to the same pressure value). With the new MCE/P, it is sufficient to set the data on one of the devices, and it will be automatically propagated to the other pumps of the system.

MODES OF OPERATION



PERFORMANCE CURVES WITHOUT INVERTER

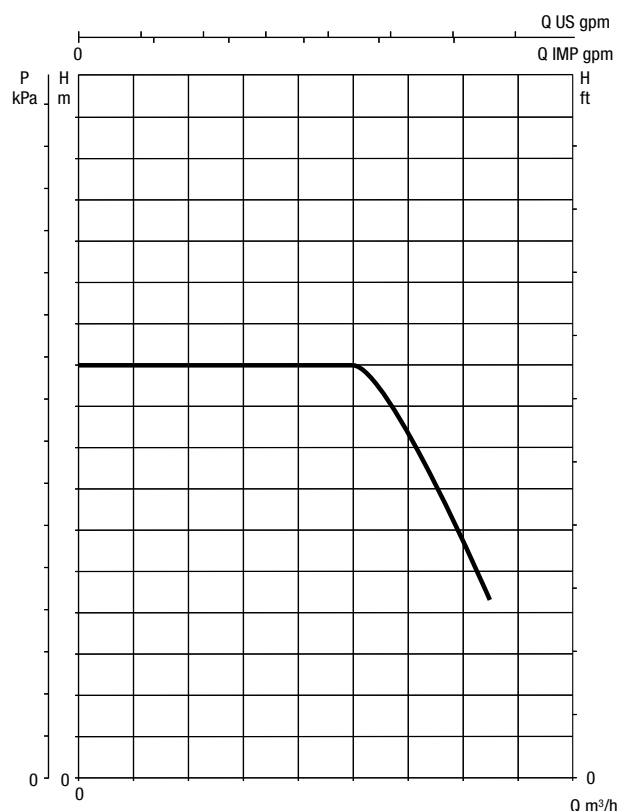

PERFORMANCE CURVES WITH INVERTER

The inverter is capable of maintaining a constant pressure even when the flow rate varies.

The operating pressure can be adjusted by the user.

A good pressure set-point is between 1/3 and 2/3 of the maximum head of the electric pump. In this way, high efficiency of the pump is maintained, together with maximum saving.

In addition, the MCE/P does not block the pump if the pressure is not reached, but the flow is present. This prevents service interruptions in case of high flows.

For more information refer to the technical appendix.

MATERIALS

N.	PARTS*	MATERIALS
1	PUMP BODY	TECHNOPOLYMER A
4	IMPELLER	TECHNOPOLYMER B
6	DIFFUSER	TECHNOPOLYMER B
7	SHAFT WITH ROTOR	AISI 303 STAINLESS STEEL X10 CrNi S 1089 UNI 6900/71
16	MECHANICAL SEAL	SILICON CARBIDE/SILICON
28	OR RING	EPDM RUBBER
36	SEAL HOLDING DISC	AISI 304 STAINLESS STEEL X5 CrNi 1810 UNI 6900/71
57a	INTERMEDIATE STAGE	TECHNOPOLYMER B
69	LINER	AISI 304 STAINLESS STEEL X5 CrNi 1810 UNI 6900/71
98	DIFFUSER BODY	TECHNOPOLYMER B
271	CENTERING BUSHING	BRONZE B14
304	CONVEYOR	TECHNOPOLYMER B
8	DNM (standard for KVCE only)	

* In contact with the liquid.

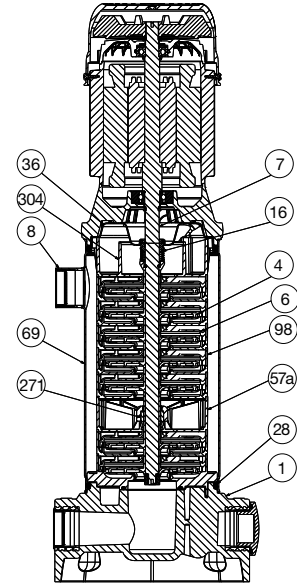
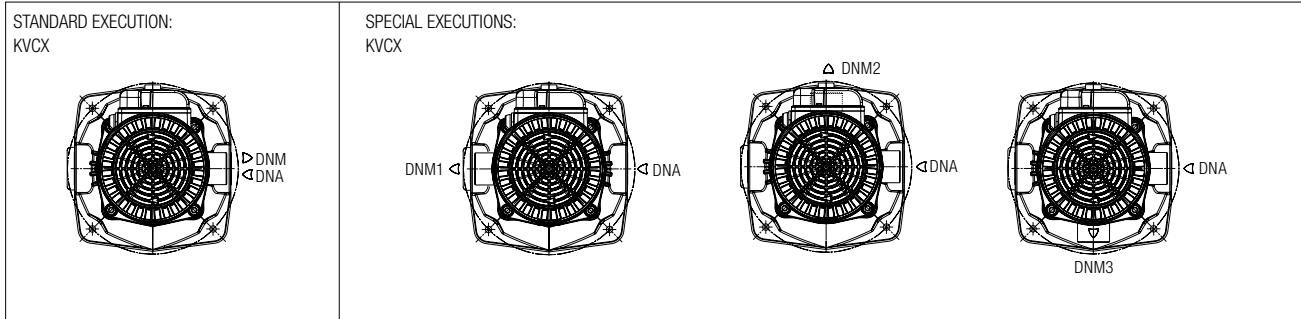
**KVCE SUCTION AND DELIVERY PORT ORIENTATION**

SELECTION TABLE - KVCE 30

MODEL	Q=m ³ /h	0	0,6	1,2	1,8	2,4	3	3,3
	Q=l/min	0	10	20	30	40	50	55
KVCE 35-30 M MCE11/P	H (m)	45,6	43,2	39,1	34,1	28,2	20,2	15,6
KVCE 45-30 M MCE11/P		56,6	53,5	48,4	42,0	34,6	24,5	19,0
KVCE 50-30 M MCE11/P		69,8	66,2	59,9	52,2	43,1	30,9	23,9
KVCE 60-30 M MCE11/P		82,0	77,0	70,0	61,0	49,5	35,5	27,5
KVCE 70-30 M MCE11/P		95,0	90,0	81,5	71,0	58,7	42,0	32,5

SELECTION TABLE - KVCE 50

MODEL	Q=m ³ /h	0	0,6	1,2	1,8	2,4	3	3,3	3,9	4,8
	Q=l/min	0	10	20	30	40	50	55	65	80
KVCE 30-50 M MCE11/P	H (m)	41,1	40,3	39,0	37,3	34,7	31,6	29,7	25,3	17,1
KVCE 40-50 M MCE11/P		54,9	53,7	52,0	49,7	46,3	42,1	39,6	33,7	22,9
KVCE 55-50 M MCE11/P		68,6	67,1	65,0	62,1	57,9	52,7	49,5	42,1	28,6
KVCE 65-50 M MCE15/P		82,3	80,6	78,0	74,6	69,4	63,2	59,4	50,6	34,3
KVCE 75-50 M MCE15/P		96,0	94,0	91,0	87,0	81,0	73,8	69,3	59,0	40,0

SELECTION TABLE - KVCE 80

MODEL	Q=m ³ /h	0	0,6	1,2	1,8	2,4	3	3,3	3,9	4,8	5,4	6	7,2
	Q=l/min	0	10	20	30	40	50	55	65	80	90	100	120
KVCE 30-80 M MCE11/P	H (m)	46,6	45,8	44,6	43,4	41,8	39,5	38,0	35,2	29,8	25,5	21,0	11,0
KVCE 40-80 M MCE11/P		58,8	57,9	56,5	55,0	53,1	50,3	48,5	45,0	38,4	33,1	27,6	15,1
KVCE 45-80 M MCE15/P		71,3	70,2	68,7	66,9	64,7	61,4	59,4	55,3	47,5	41,4	34,9	19,9
KVCE 55-80 M MCE15/P		84,0	82,8	81,2	79,2	76,6	72,9	70,7	66,0	57,1	50,3	42,8	25,5
KVCE 65-80 M MCE22/P		97,0	95,7	94,0	91,8	88,9	84,7	82,5	77,2	67,3	59,9	51,5	32,0

SELECTION TABLE - KVCE 120

MODEL	Q=m ³ /h	0	0,6	1,2	1,8	2,4	3	3,3	3,9	4,8	5,4	6	7,2	8,4	9,6	10,8	12
	Q=l/min	0	10	20	30	40	50	55	65	80	90	100	120	140	160	180	200
KVCE 35-120 M MCE15/P	H (m)	46,2	46,1	45,7	45,3	44,8	44,0	43,7	42,7	40,9	39,3	37,4	33,7	29,4	24,2	18,0	11,0
KVCE 45-120 M MCE22/P		62,4	62,0	61,4	60,8	60,1	59,1	58,6	57,5	55,3	53,4	51,4	46,2	40,6	34,0	26,3	17,0
KVCE 60-120 T MCE30/P		78,0	77,5	76,7	75,9	75,1	73,9	73,3	71,5	68,3	65,9	63,2	58,0	51,0	43,4	35,0	24,5
KVCE 70-120 T MCE30/P		95,0	94,3	93,4	92,5	91,4	89,8	88,9	86,8	83,2	80,5	77,9	71,7	63,9	54,7	44,0	31,0
KVCE 85-120 T MCE30/P		112,7	111,6	110,3	109,0	107,6	105,7	104,5	101,9	97,5	94,1	89,9	81,6	72,1	61,2	48,9	34,0

KVCE 30 - VERTICAL AXIS MULTISTAGE CENTRIFUGAL PUMPS WITH MCE/P INVERTER FOR PRESSURISATION SYSTEMS

Pumped liquid temperature range: from 0 °C to +35 °C for domestic use - from 0 °C to +40 °C for the other uses

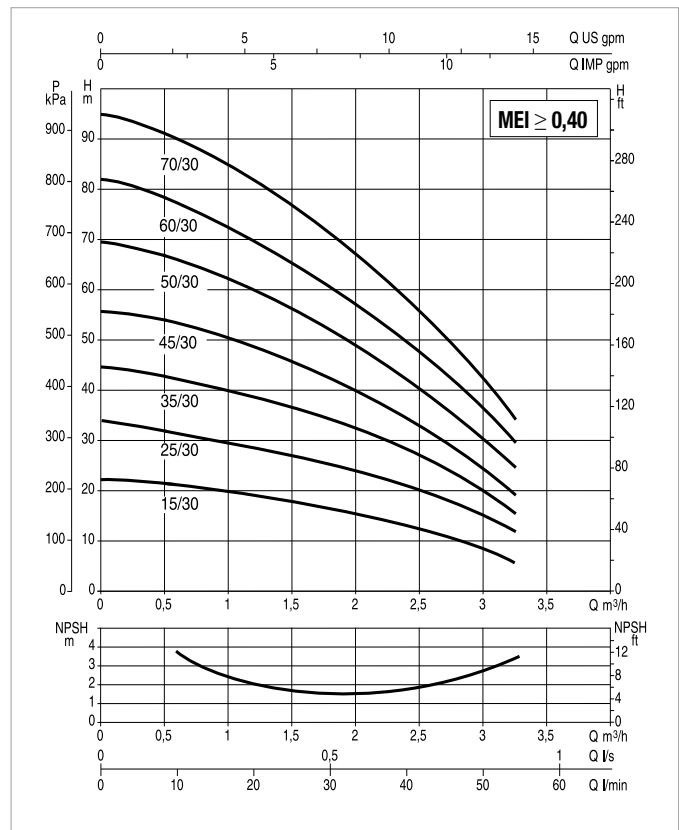
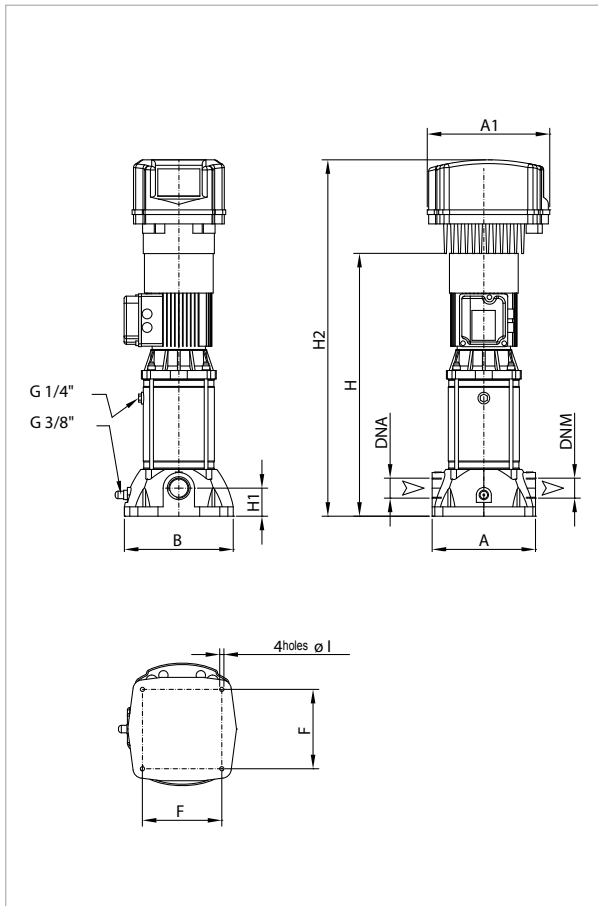

See hydraulic efficiency details on page 241.

The performance curves are based on kinematic viscosity values = 1 mm²/s and density equal to 1000 kg/m³. Curve tolerance according to ISO 9906.

MODEL	ELECTRICAL DATA					
	N. IMPELLERS	POWER INPUT 50 Hz	P2 NOMINAL		In A	r.p.m.
			kW	HP		
KVCE 35-30 M MCE11/P	4	1 x 230 V	0,45	0,6	6,63	2822
KVCE 45-30 M MCE11/P	5	1 x 230 V	0,55	0,75	7,71	2788
KVCE 50-30 M MCE11/P	6	1 x 230 V	0,75	1,0	8,36	2858
KVCE 60-30 M MCE11/P	7	1 x 230 V	0,8	1,1	9,19	2842
KVCE 70-30 M MCE11/P	8	1 x 230 V	1,0	1,36	10,2	2850

MODEL	A	B	F	H	H1	H2	ØI	DNA GAS	DNM GAS	PACKING DIMENSIONS			VOLUME (m ³)	WEIGHT kg
										L/A	L/B	H		
KVCE 35-30 M MCE11/P	221	235	170	562	60	762	9	1"¼	1"¼	300	360	856	0,092	19,6
KVCE 45-30 M MCE11/P	221	235	170	562	60	762	9	1"¼	1"¼	300	360	856	0,092	19,6
KVCE 50-30 M MCE11/P	221	235	170	655	60	855	9	1"¼	1"¼	300	360	935	0,101	20,9
KVCE 60-30 M MCE11/P	221	235	170	655	60	855	9	1"¼	1"¼	300	360	935	0,101	20,9
KVCE 70-30 M MCE11/P	221	235	170	682	60	882	9	1"¼	1"¼	300	360	976	0,105	22,7

KVCE 50 - VERTICAL AXIS MULTISTAGE CENTRIFUGAL PUMPS WITH MCE/P INVERTER FOR PRESSURISATION SYSTEMS

Pumped liquid temperature range: from 0 °C to +35 °C for domestic use - from 0 °C to +40 °C for the other uses

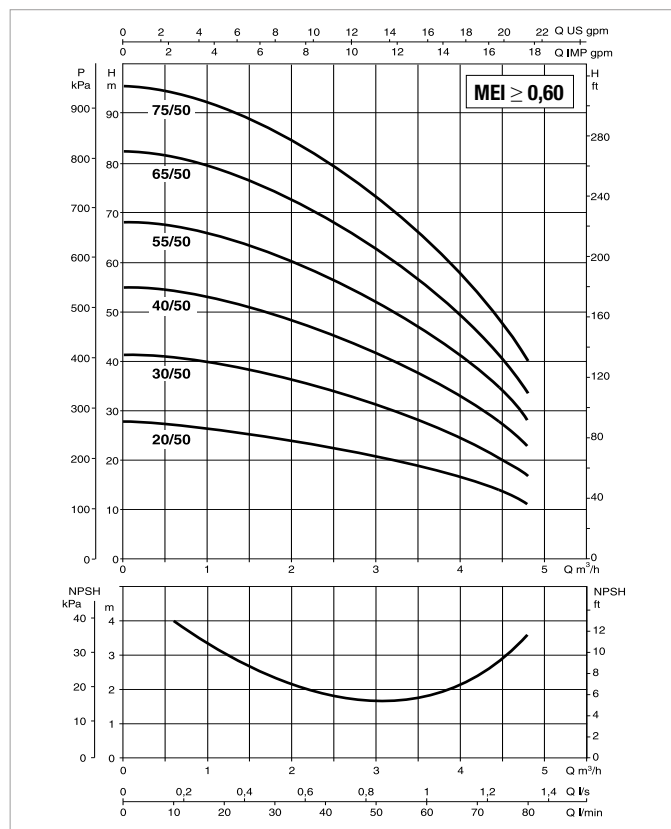
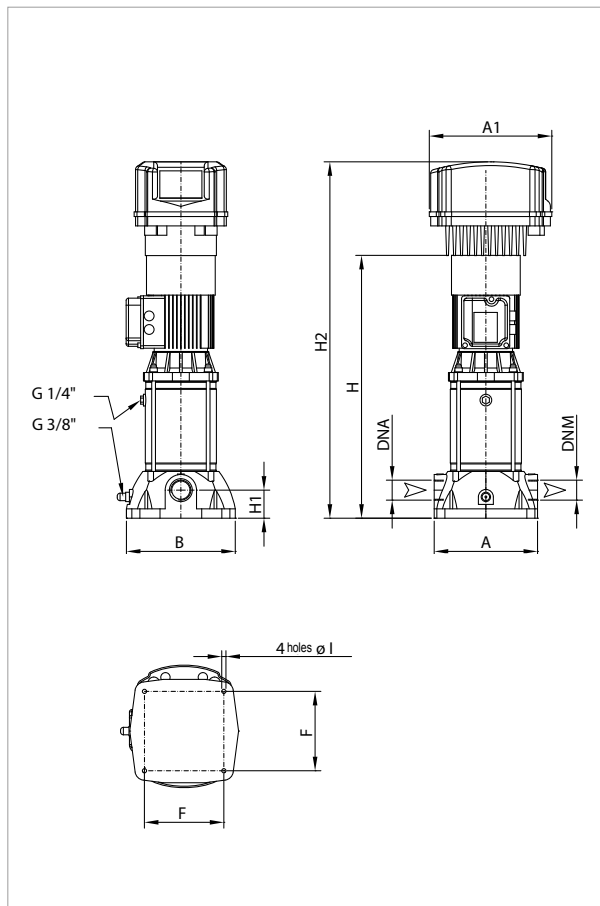

See hydraulic efficiency details on page 241.
The performance curves are based on kinematic viscosity values = 1 mm²/s and density equal to 1000 kg/m³. Curve tolerance according to ISO 9906.

MODEL	ELECTRICAL DATA					
	N. IMPELLERS	POWER INPUT 50 Hz	P2 NOMINAL		In A	r.p.m.
			kW	HP		
KVCE 30-50 M MCE11/P	3	1 x 230 V	0,55	0,75	8,51	2714
KVCE 40-50 M MCE11/P	4	1 x 230 V	0,8	1,1	10,2	2816
KVCE 55-50 M MCE11/P	5	1 x 230 V	1,0	1,4	12	2795
KVCE 65-50 M MCE15/P	6	1 x 230 V	1,1	1,5	14,6	2870
KVCE 75-50 M MCE15/P	7	1 x 230 V	1,5	2,0	16,6	2847

MODEL	A	B	F	H	H1	H2	ØI	DNA GAS	DNM GAS	PACKING DIMENSIONS			VOLUME (m ³)	WEIGHT kg
										L/A	L/B	H		
KVCE 30-50 M MCE11/P	221	235	170	506	60	706	9	1"¼	1"¼	300	360	800	0,086	19,1
KVCE 40-50 M MCE11/P	221	235	170	562	60	762	9	1"¼	1"¼	300	360	856	0,092	22,4
KVCE 55-50 M MCE11/P	221	235	170	562	60	762	9	1"¼	1"¼	300	360	856	0,092	22,4
KVCE 65-50 M MCE15/P	221	235	170	655	60	855	9	1"¼	1"¼	300	360	935	0,101	26,4
KVCE 75-50 M MCE15/P	221	235	170	655	60	855	9	1"¼	1"¼	300	360	935	0,101	26,4

KVCE 80 - VERTICAL AXIS MULTISTAGE CENTRIFUGAL PUMPS WITH MCE/P INVERTER FOR PRESSURISATION SYSTEMS

Pumped liquid temperature range: from 0 °C to +35 °C for domestic use - from 0 °C to +40 °C for the other uses

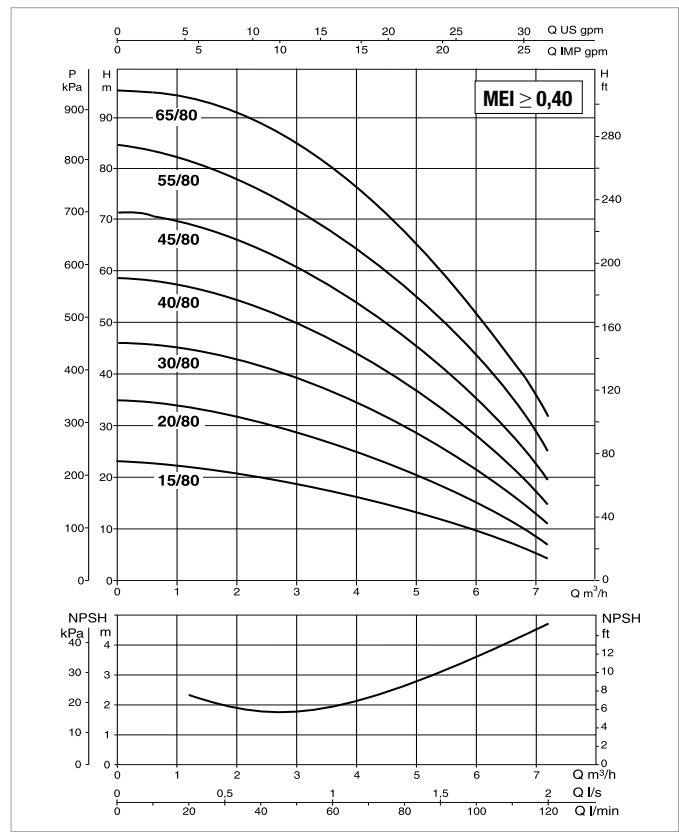
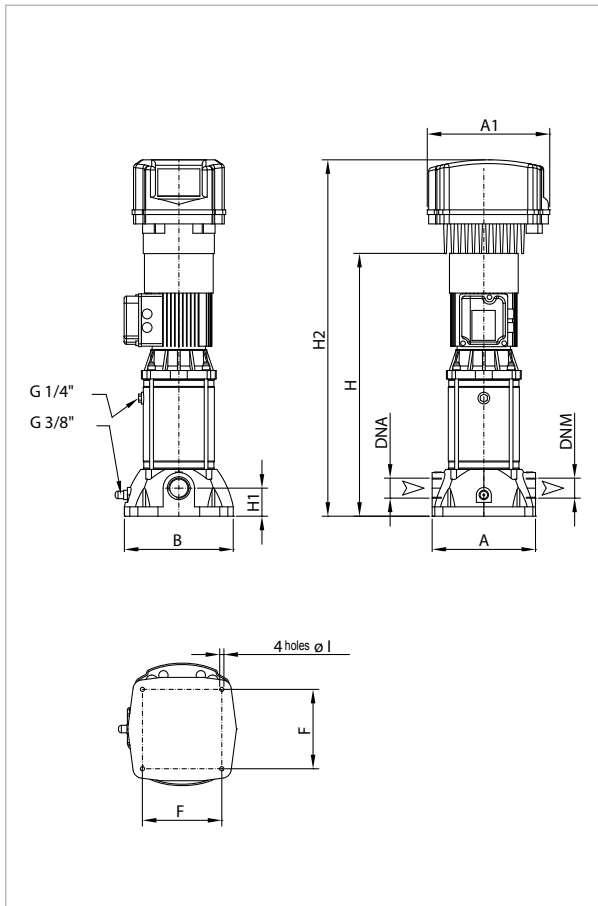

See hydraulic efficiency details on page 241.

The performance curves are based on kinematic viscosity values = 1 mm²/s and density equal to 1000 kg/m³. Curve tolerance according to ISO 9906.

MODEL	ELECTRICAL DATA					
	N. IMPELLERS	POWER INPUT 50 Hz	P2 NOMINAL		In A	r.p.m.
			KW	HP		
KVCE 30-80 M MCE11/P	4	1 x 230 V	0,8	1,1	9,99	2827
KVCE 40-80 M MCE11/P	5	1 x 230 V	1,0	1,36	11,7	2805
KVCE 45-80 M MCE15/P	6	1 x 230 V	1,1	1,5	14,2	2880
KVCE 55-80 M MCE15/P	7	1 x 230 V	1,5	2,0	16	2851
KVCE 65-80 M MCE22/P	8	1 x 230 V	2,2	3,0	18	2852

MODEL	A	B	F	H	H1	H2	ØI	DNA GAS	DNM GAS	PACKING DIMENSIONS			VOLUME (m ³)	WEIGHT kg
										L/A	L/B	H		
KVCE 30-80 M MCE11/P	221	235	170	562	60	762	9	1"¼	1"¼	300	360	856	0,092	22,4
KVCE 40-80 M MCE11/P	221	235	170	562	60	762	9	1"¼	1"¼	300	360	856	0,092	22,4
KVCE 45-80 M MCE15/P	221	235	170	655	60	855	9	1"¼	1"¼	300	360	935	0,101	26,4
KVCE 55-80 M MCE15/P	221	235	170	655	60	855	9	1"¼	1"¼	300	360	935	0,101	26,4
KVCE 65-80 M MCE22/P	221	235	170	680	60	880	9	1"¼	1"¼	300	360	960	0,104	27,4

KVCE 120 - VERTICAL AXIS MULTISTAGE CENTRIFUGAL PUMPS WITH MCE/P INVERTER FOR PRESSURISATION SYSTEMS

Pumped liquid temperature range: from 0 °C to +35 °C for domestic use - from 0 °C to +40 °C for the other uses

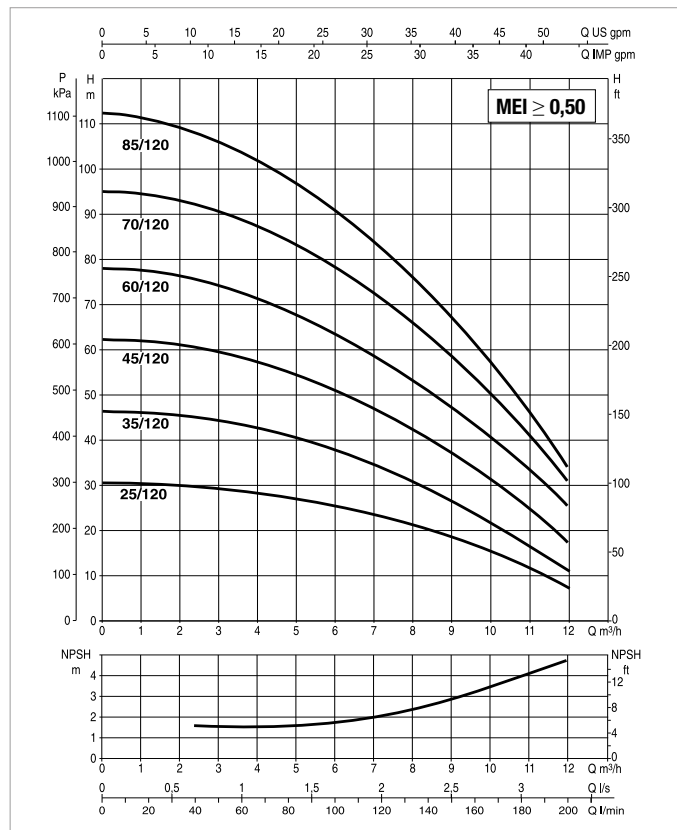
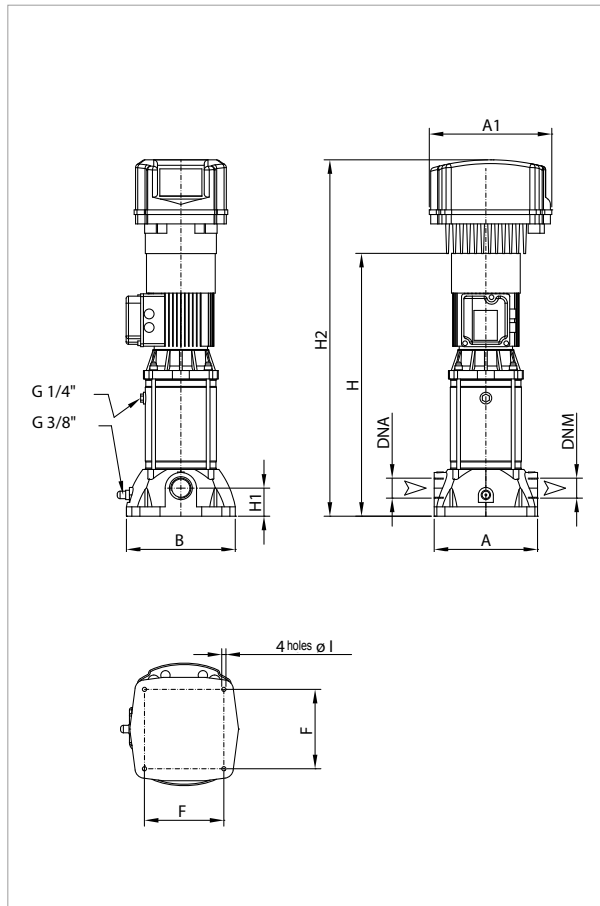

See hydraulic efficiency details on page 241.

The performance curves are based on kinematic viscosity values = 1 mm²/s and density equal to 1000 kg/m³. Curve tolerance according to ISO 9906.

MODEL	N. IMPELLERS	POWER INPUT 50 Hz	P2 NOMINAL		In A	r.p.m.
			kW	HP		
KVCE 35-120 M MCE15/P	3	1 x 230 V	1,1	1,5	16	2857
KVCE 45-120 M MCE22/P	4	1 x 230 V	1,84	2,5	19,5	2835
KVCE 60-120 T MCE30/P	5	3 x 400 V	2,2	3,0	6,91	2765
KVCE 70-120 T MCE30/P	6	3 x 400 V	2,2	3,0	8,26	2794
KVCE 85-120 T MCE30/P	7	3 x 400 V	2,2	3,0	9,18	2755

MODEL	A	B	F	H	H1	H2	ØI	DNA GAS	DNM GAS	PACKING DIMENSIONS			VOLUME (m³)	WEIGHT kg
										L/A	L/B	H		
KVCE 35-120 M MCE15/P	221	235	170	505	60	705	9	1 1/4"	1 1/4"	300	360	785	0,085	23,8
KVCE 45-120 M MCE22/P	221	235	170	635	60	835	9	1 1/4"	1 1/4"	300	360	915	0,099	29,0
KVCE 60-120 T MCE30/P	221	235	170	635	60	835	9	1 1/4"	1 1/4"	300	360	915	0,099	27,1
KVCE 70-120 T MCE30/P	221	235	170	730	60	930	9	1 1/4"	1 1/4"	300	360	1010	0,109	30,8
KVCE 85-120 T MCE30/P	221	235	170	730	60	930	9	1 1/4"	1 1/4"	300	360	1010	0,109	30,8

KVE 3-6-10

VERTICAL AXIS MULTISTAGE CENTRIFUGAL PUMPS WITH MCE/P INVERTER



TECHNICAL DATA

Operating range:

from 1,8 to 13,5 m³/h, with head up to 158 metres.

Liquid temperature range:

from 0 °C to 35 °C for domestic use,
from -15 °C to 80 °C for other uses.

Pumped liquid: clean, free of solids and abrasives, non-viscous, non-aggressive, non-crystallised and chemically neutral.

Maximum ambient temperature: + 40 °C.

Maximum operating pressure: 18 bar (1800 kPa).

Standard voltage:

single-phase 1x230 V / 50/60 Hz.

three-phase 3x400 V / 50 Hz.

Protection class: IP 55

Insulation class: F.

Installation: fixed, vertical position.

APPLICATIONS

Vertical multistage centrifugal pump suitable for medium to large user water systems. Recommended for pressurisation units, boiler supply, hot water and cooling water circulation, fire fighting and washing systems, drinking water supply and filling of pressure vessels, sprinkler and watering systems and water purification systems.

ADVANTAGES OF USE

Operating pressure stability – **Excellent energy savings** (up to 60 %) – Reduced hammering effects – Reduced space requirements – Less maintenance – Reduced pump wear – Less power factor correction required – Less water consumption – Integrated protections.

CONSTRUCTION FEATURES OF THE PUMP

Cast iron delivery and suction bodies treated against corrosion. Impellers, diffuser bodies and diffusers in technopolymer. AISI 304 stainless steel pump liner and adjustment rings. Pump shaft in AISI 416 stainless steel. AISI 316 stainless steel sliding bushing.

Bronze sliding bushing guide, self-lubricated using the pumped liquid itself. Carbon/ceramic mechanical seal. Rigid coupling motor shaft to pump shaft connection. Threaded counter-flanges supplied as standard.

CONSTRUCTION FEATURES OF THE MOTOR

Shaft with rotor running on permanently lubricated ball bearings, oversized to ensure low noise and durability. Construction according to CEI 2-3. Controlled by MCE inverter. Insulation class: F. Standard single-phase voltage: 1x230 V / 50-60 Hz. Special version on request: three-phase 3x400 V / 50 Hz or three-phase 3x460 V / 60 Hz. Standard three-phase voltage: 3x400 V / 50 Hz. Special version on request: 3x460 V / 60 Hz.

MATERIALS

N.	PARTS*	MATERIALS
4	IMPELLER	TECHNOPOLYMER B
6	DIFFUSER	TECHNOPOLYMER B
7A	PUMP SHAFT	AISI 416 STAINLESS STEEL X12 CrS 13 UNI 6900/71
16	MECHANICAL SEAL	CARBON / CERAMIC
28	OR RING	EPDM RUBBER
69	LINER	AISI 304 STAINLESS STEEL X5 CrNi 1810 UNI 6900/71
95	OR RING	EPDM RUBBER
96	SUCTION BODY	CAST IRON 200 UNI ISO 185
97	DELIVERY BODY	CAST IRON 200 UNI ISO 185
98	DIFFUSER BODY	TECHNOPOLYMER B

* In contact with the liquid.

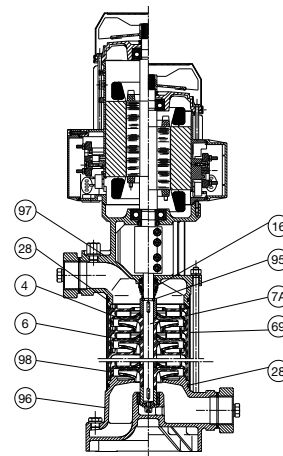

ORIENTATION OF THE SUCTION AND DELIVERY CONNECTORS:

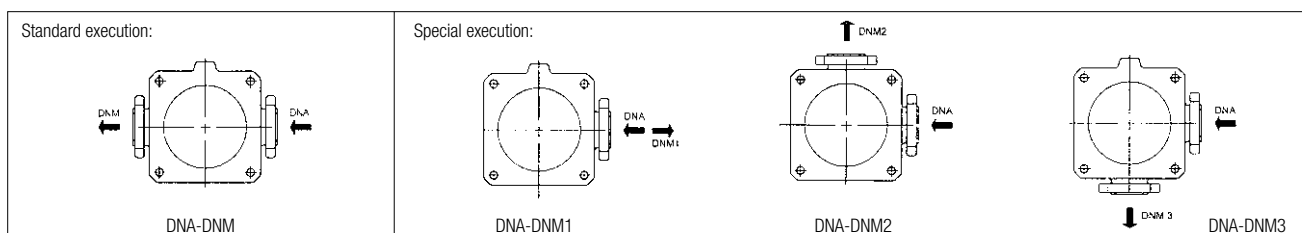

MCE/P INVERTER



CONSTRUCTION FEATURES OF THE ELECTRONICS: MCE/P INVERTER

The inverter continuously adjusts the rotation speed of the electric pump, keeping the pressure constant, even when the flow rate varies. The other electric pumps, also with variable speed, are activated in cascade after the first one has reached maximum speed. Through modulation, they compensate the pressure fluctuations of the system.

For every operating cycle, it is possible to switch the restart to a different pump, therefore ensuring even use of all electric pumps.

It is possible to set operation times for each individual pump, switching to another pump after such set times.

The "SP" pressure can be adjusted by the user using the "+" and "-" keys found on the MCE/P (as a rule, all the pumps are set to the same pressure value). With the new MCE/P, it is sufficient to set the data on one of the devices, and it will be automatically propagated to the other pumps of the system.

MODES OF OPERATION

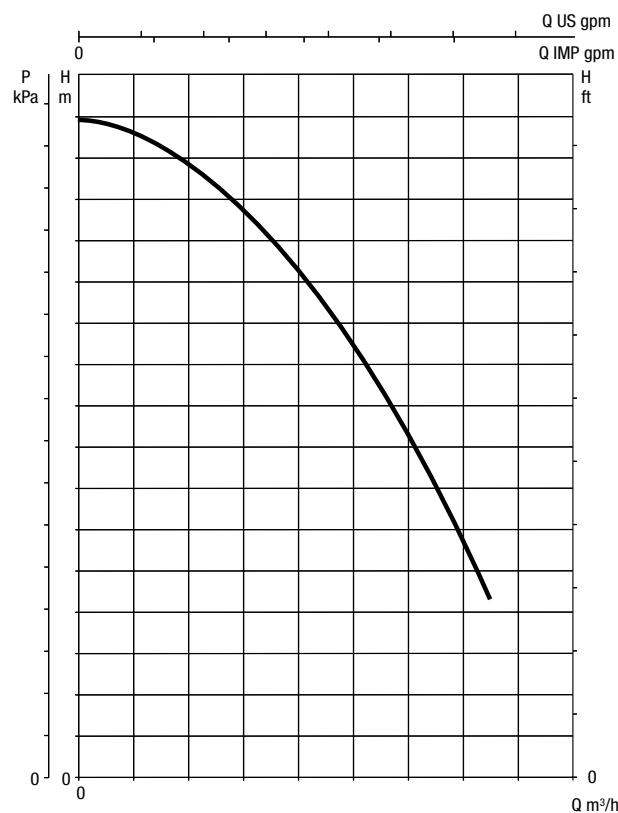

PERFORMANCE CURVES WITHOUT INVERTER

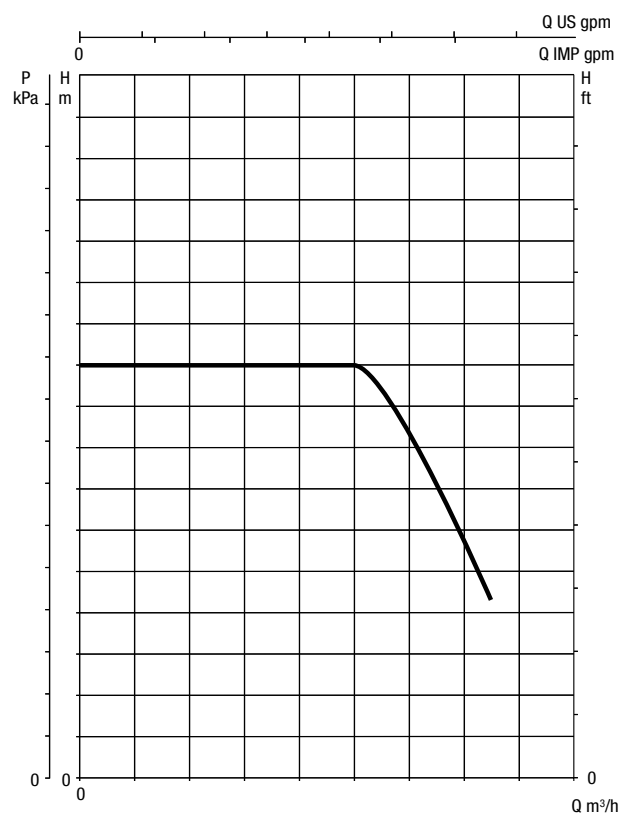

PERFORMANCE CURVES WITH INVERTER

The inverter is capable of maintaining a constant pressure even when the flow rate varies.

The operating pressure can be adjusted by the user.

A good pressure set-point is between 1/3 and 2/3 of the maximum head of the electric pump. In this way, high efficiency of the pump is maintained, together with maximum saving.

In addition, the MCE/P does not block the pump if the pressure is not reached, but the flow is present. This prevents service interruptions in case of high flows.

For more information refer to the technical appendix.

KVE 3-6-10**VERTICAL AXIS MULTISTAGE CENTRIFUGAL PUMPS WITH MCE/P INVERTER****SELECTION TABLE - KVE 3**

MODEL	P2 NOMINAL		Q=m ³ /h	0	1,8	3,6	5,4	7,2
	kW	HP	Q=l/min	0	30	60	90	120
KVE 3/10 M MCE15/P	1,1	1,5	H (m)	88	77	63,5	45,7	21
KVE 3/12 M MCE15/P	1,5	2		105,6	92,4	76,2	54,8	25,2
KVE 3/15 M MCE22/P	1,85	2,5		132	115,5	95,3	68,6	31,5
KVE 3/18 T MCE30/P	2,2	3		158,4	138,6	114,3	82,3	37,8

SELECTION TABLE - KVE 6

MODEL	P2 NOMINAL		Q=m ³ /h	0	1,8	3,6	5,4	7,2	8,4	10,2	12
	kW	HP	Q=l/min	0	30	60	90	120	140	170	200
KVE 6/7 M MCE11/P	1,1	1,5	H (m)	62,3	57,8	51,5	42,5	29,5	18,6		
KVE 6/9 M MCE15/P	1,5	2		80,1	74,3	66,2	54,6	38	23,9	16,4	12,0
KVE 6/11 M MCE15/P	1,84	2,5		97,9	90,8	81	66,8	46,4	29,2	24,2	18,0
KVE 6/15 T MCE30/P	2,2	3		133,5	123,8	110,4	91,1	63,3	39,8	34,0	26,3

SELECTION TABLE - KVE 10

MODEL	P2 NOMINAL		Q=m ³ /h	0	1,8	3,6	5,4	7,2	8,4	10,2	12	13,8
	kW	HP	Q=l/min	0	30	60	90	120	140	170	200	230
KVE 10/4 M MCE11/P	1,1	1,5	H (m)	38,2	37,4	36,2	34,4	32	29,7	25,5	20	12,6
KVE 10/5 M MCE15/P	1,5	2		47,8	46,8	45,2	43	40	37,2	31,9	25	15,8
KVE 10/6 M MCE22/P	1,84	2,5		57,3	56,1	54,2	51,6	48	44,6	38,2	30	18,9
KVE 10/8 T MCE30/P	2,2	3		76,4	74,8	72,3	68,8	64	59,4	51	40	25,2

KVE 3 - VERTICAL AXIS MULTISTAGE CENTRIFUGAL PUMPS WITH MCE/P INVERTER FOR PRESSURISATION SYSTEMS

Pumped liquid temperature range: from 0 °C to +35 °C for domestic use - from -15 °C to +80 °C for the other uses.

Maximum ambient temperature: +40 °C

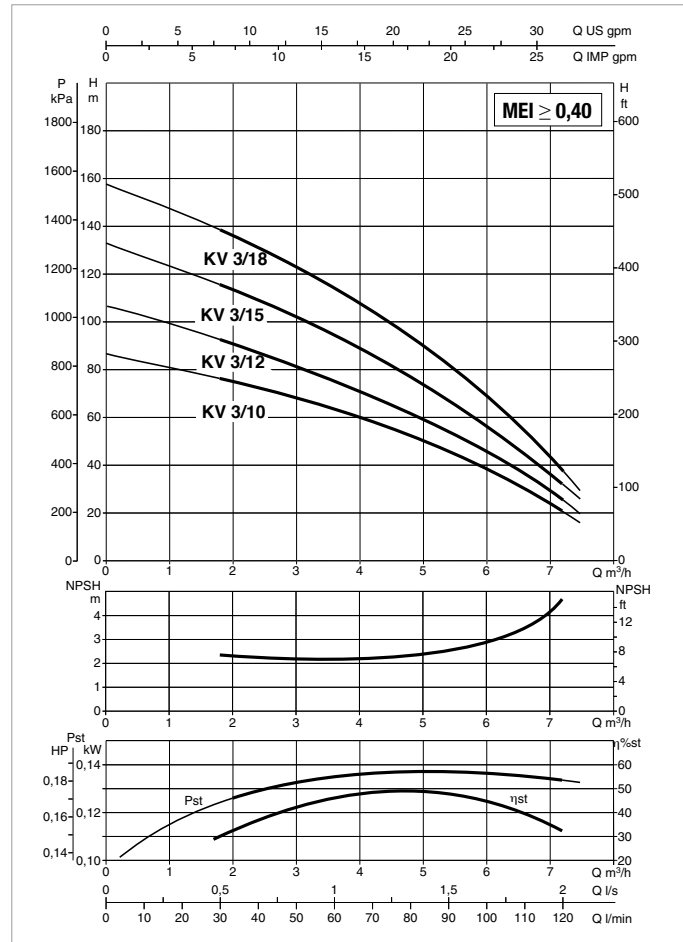
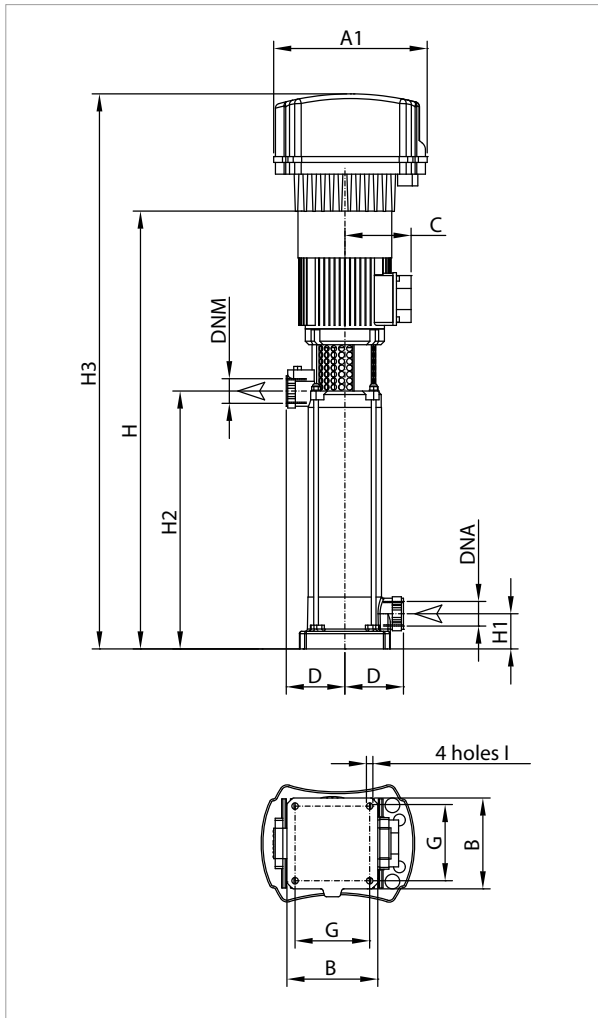

See hydraulic efficiency details on page 241.

The performance curves are based on kinematic viscosity values = 1 mm²/s and density equal to 1000 kg/m³. Curve tolerance according to ISO 9906.

MODEL	POWER INPUT 50 Hz	P2 NOMINAL		In A	r.p.m.
		kW	HP		
KVE 3/10 M MCE15/P	1 x 230 V	1,1	1,5	13,5	2890
KVE 3/12 M MCE15/P	1 x 230 V	1,5	2	15,4	2851
KVE 3/15 M MCE22/P	1 x 230 V	1,85	2,5	18,2	2844
KVE 3/18 T MCE30/P	3 x 400 V	2,2	3	7,06	2854

MODEL	A1	B	C	D	G	I	H	H1	H2	H3	DNA GAS	DNM GAS	PACKING DIMENSIONS			VOLUME m³	WEIGHT kg
													L/A	L/B	H		
KVE 3/10 M MCE15/P	262	155	140	100	127	11	779	60	472	979	1,¼"	1¼"	1350	255	310	0,107	30,7
KVE 3/12 M MCE15/P	262	155	160	100	127	11	843	60	536	1043	1,¼"	1¼"	1350	255	310	0,107	32,4
KVE 3/15 M MCE22/P	262	155	160	100	127	11	1013	60	632	1213	1,¼"	1¼"	1350	255	310	0,107	36,3
KVE 3/18 T MCE30/P	262	155	160	100	127	11	1109	60	728	1304	1,¼"	1¼"	1350	255	310	0,107	40,2

KVE 6 - VERTICAL AXIS MULTISTAGE CENTRIFUGAL PUMPS WITH MCE/P INVERTER FOR PRESSURIZATION SYSTEMS

Pumped liquid temperature range: from 0 °C to +35 °C for domestic use - from -15 °C to +80 °C for the other uses.
 Maximum ambient temperature: +40 °C

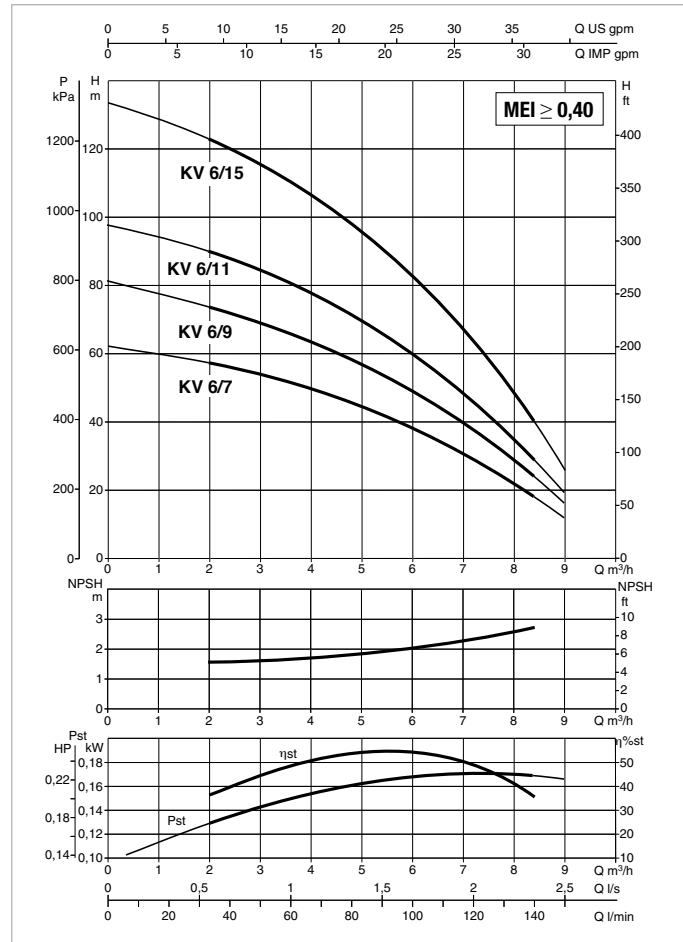
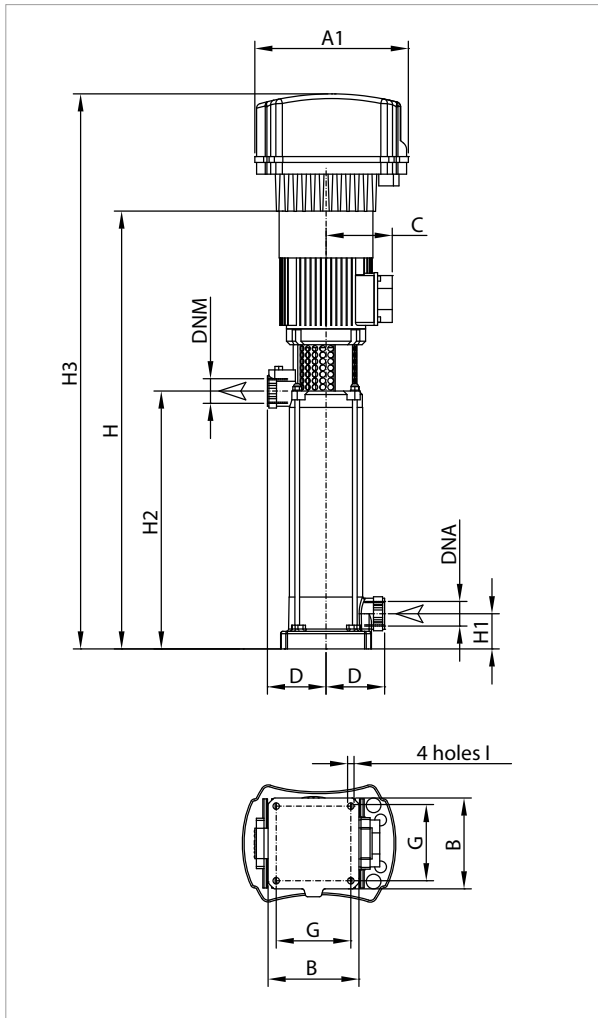

See hydraulic efficiency details on page 241.

The performance curves are based on kinematic viscosity values = 1 mm²/s and density equal to 1000 kg/m³. Curve tolerance according to ISO 9906.

MODEL	POWER INPUT 50 Hz	P2 NOMINAL		In A	r.p.m.
		kW	HP		
KVE 6/7 M MCE11/P	1 x 230 V	1,1	1,5	12,7	2890
KVE 6/9 M MCE15/P	1 x 230 V	1,5	2	15,5	2856
KVE 6/11 M MCE15/P	1 x 230 V	1,84	2,5	17,8	2825
KVE 6/15 T MCE30/P	3 x 400 V	2,2	3	7,41	2832

MODEL	A1	B	C	D	G	I	H	H1	H2	H3	DNA GAS	DNM GAS	PACKING DIMENSIONS			VOLUME m³	WEIGHT kg
													L/A	L/B	H		
KVE 6/7 M MCE11/P	262	155	140	100	127	11	683	60	376	883	1,¼"	1¼"	1350	255	310	0,107	29,6
KVE 6/9 M MCE15/P	262	155	160	100	127	11	747	60	440	947	1,¼"	1¼"	1350	255	310	0,107	31,2
KVE 6/11 M MCE15/P	262	155	160	100	127	11	885	60	504	1085	1,¼"	1¼"	1350	255	310	0,107	32,1
KVE 6/15 T MCE30/P	262	155	160	100	127	11	1013	60	632	1213	1,¼"	1¼"	1350	255	310	0,107	38,9

KVE 10 - VERTICAL AXIS MULTISTAGE CENTRIFUGAL PUMPS WITH MCE/P INVERTER FOR PRESSURISATION SYSTEMS

Pumped liquid temperature range: from 0 °C to +35 °C for domestic use - from -15 °C to +80 °C for the other uses.

Maximum ambient temperature: +40 °C

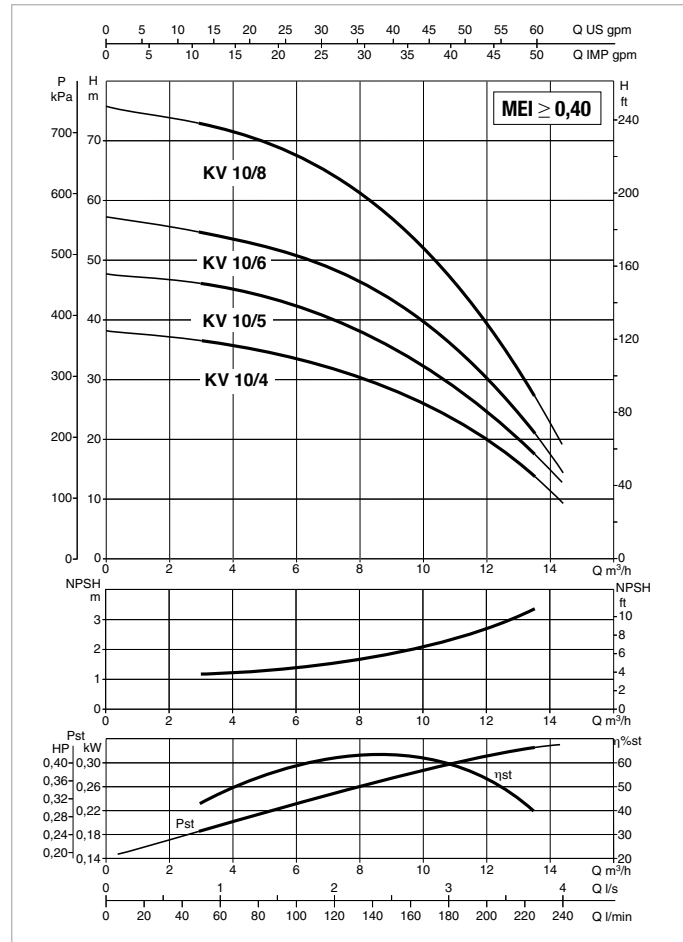
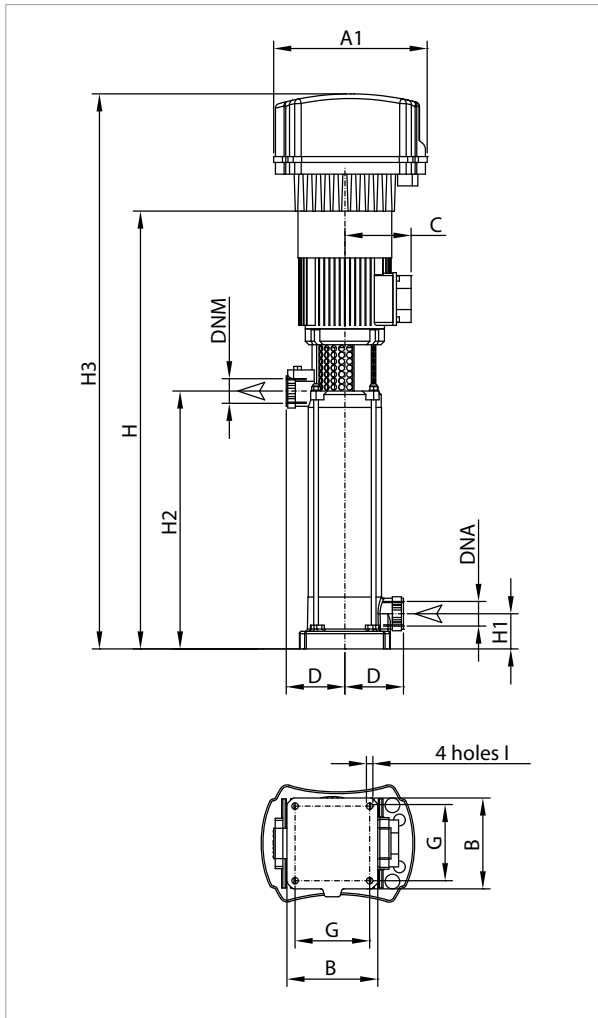

See hydraulic efficiency details on page 241.

The performance curves are based on kinematic viscosity values = 1 mm²/s and density equal to 1000 kg/m³. Curve tolerance according to ISO 9906.

MODEL	POWER INPUT 50 Hz	P2 NOMINAL		In A	r.p.m.
		kW	HP		
KVE 10/4 M MCE11/P	1 x 230 V	1,1	1,5	16,3	2853
KVE 10/5 M MCE15/P	1 x 230 V	1,5	2	17,3	2827
KVE 10/6 M MCE22/P	1 x 230 V	1,84	2,5	20,2	2813
KVE 10/8 T MCE30/P	3 x 400 V	2,2	3	8,01	2810

MODEL	A1	B	C	D	G	I	H	H1	H2	H3	DNA GAS	DNM GAS	PACKING DIMENSIONS			VOLUME m³	WEIGHT kg
													L/A	L/B	H		
KVE 10/4 M MCE11/P	262	155	140	100	127	11	587	60	280	787	1,¼"	1,¼"	1350	255	310	0,107	27,5
KVE 10/5 M MCE15/P	262	155	160	100	127	11	619	60	312	819	1,¼"	1,¼"	1350	255	310	0,107	29
KVE 10/6 M MCE22/P	262	155	160	100	127	11	725	60	344	925	1,¼"	1,¼"	1350	255	310	0,107	32,3
KVE 10/8 T MCE30/P	262	155	160	100	127	11	789	60	408	989	1,¼"	1,¼"	1350	255	310	0,107	34,5

NKVE 10-15-20-32-45-65-95

VERTICAL AXIS MULTISTAGE CENTRIFUGAL PUMPS WITH MCE/P INVERTER



TECHNICAL DATA

Operating range:

from 4 to 118 m³/h with head up to 231 metres.

Pumped liquid: clean, free of solids and abrasives, non-viscous, non-crystallised and chemically neutral, with properties similar to water.

Pumped liquid temperature range: from -15 °C to +80 °C.

Maximum ambient temperature: +40 °C.

Maximum operating pressure:

25 bar (2500kPa) NKV 10-15-20-65-95

32 bar (3200kPa) NKV 32-45

Installation: fixed, vertical position.

Special executions on request:

60 Hz version.

Version entirely in stainless steel.

APPLICATIONS

Vertical multistage centrifugal pump suitable for medium to large user water systems. Recommended for pressurisation units, boiler supply, hot water and cooling water circulation, fire fighting and washing systems, drinking water supply and filling of pressure vessels, sprinkler and watering systems and water purification systems.

ADVANTAGES OF USE

Operating pressure stability – **Excellent energy savings** (up to 60 %) – Reduced hammering effects – Reduced space requirements – Less maintenance – Reduced pump wear – Less power factor correction required – Less water consumption – Integrated protections.

CONSTRUCTION FEATURES OF THE PUMP

NKV 10-15-20

All the parts in contact with the liquid are rust-proof.

Microcast AISI 304 stainless steel internal pump body, ULTEM diffusers, AISI 431 pump shaft, microcast steel impellers, AISI 304 liner.

Cast iron external pump body treated with cathoporesis paint coating, cast iron support. Maintenance-free "cartridge" silicon/silicon mechanical seal, removable without removing the motor starting from 5,5 kW. Rigid motor-pump coupling.

NKV 32-45-65-95

AISI 304 stainless steel impellers, diffusers and liner, to ensure durability and high performance. AISI 431 stainless steel pump shaft. Cast iron pump body and seal disc, treated with cathoporesis paint coating. Carbon stage body bushing, to ensure durability in case of dry operation. Oversized ball bearings, fitted on the motor support to ensure duration and eliminate axial adjustments. PTFE floating adjustment ring, WRAS approved, for constant performance. Silicon carbide/graphite mechanical seal, removable without removing the motor starting from 5,5 kW. Rigid motor-pump coupling. Special version fully made of stainless steel available on request.

CONSTRUCTION FEATURES OF THE MOTOR

Shaft with rotor running on permanently lubricated ball bearings, oversized to ensure low noise and durability.

Construction according to CEI 2-3.

Controlled by MCE inverter.

Protection class: IP 55

Insulation class: F.

Standard single-phase voltage: 1x230 V / 50-60 Hz

Special version on request: three-phase 3x400 V / 50 Hz, or three-phase 3x460 V / 60 Hz

Standard three-phase voltage: 3x400 V / 50 Hz

Special version on request: 3x460 V / 60 Hz

NKVE 10-15-20-32-45-65-95

VERTICAL AXIS MULTISTAGE CENTRIFUGAL PUMPS WITH MCE/P INVERTER

MCE/P INVERTER



CONSTRUCTION FEATURES OF THE ELECTRONICS: MCE/P INVERTER

The inverter continuously adjusts the rotation speed of the electric pump, keeping the pressure constant, even when the flow rate varies. The other electric pumps, also with variable speed, are activated in cascade after the first one has reached maximum speed. Through modulation, they compensate the pressure fluctuations of the system.

For every operating cycle, it is possible to switch the restart to a different pump, therefore ensuring even use of all electric pumps.

It is possible to set operation times for each individual pump, switching to another pump after such set times.

The "SP" pressure can be adjusted by the user using the "+" and "-" keys found on the MCE/P (as a rule, all the pumps are set to the same pressure value). With the new MCE/P, it is sufficient to set the data on one of the devices, and it will be automatically propagated to the other pumps of the system.

MODES OF OPERATION

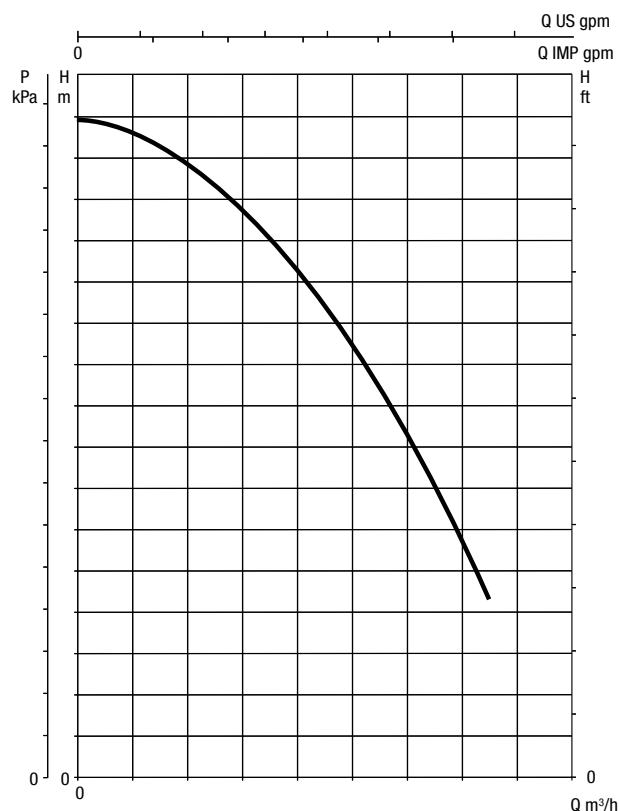

PERFORMANCE CURVES WITHOUT INVERTER

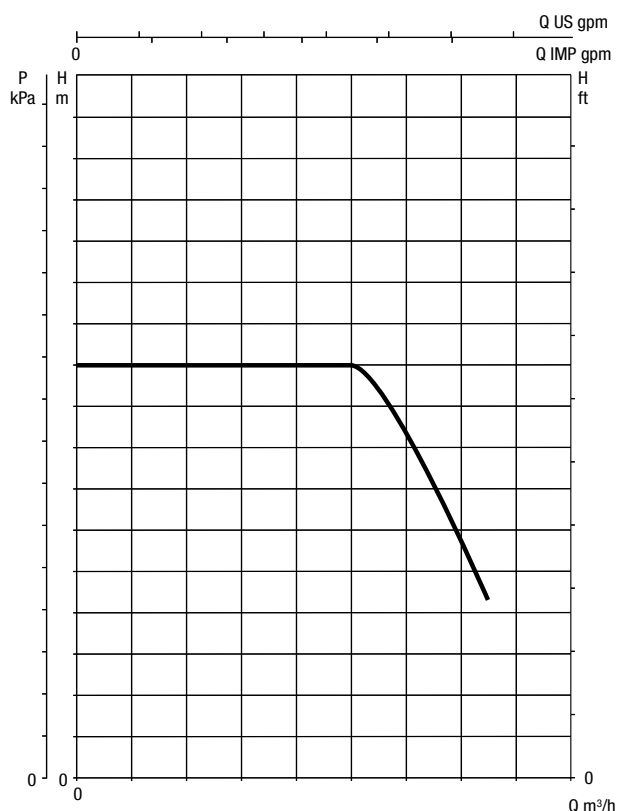

PERFORMANCE CURVES WITH INVERTER

The inverter is capable of maintaining a constant pressure even when the flow rate varies.

The operating pressure can be adjusted by the user.

A good pressure set-point is between 1/3 and 2/3 of the maximum head of the electric pump. In this way, high efficiency of the pump is maintained, together with maximum saving.

In addition, the MCE/P does not block the pump if the pressure is not reached, but the flow is present. This prevents service interruptions in case of high flows.

For more information refer to the technical appendix.

NKVE 10-15-20-32-45-65-95

VERTICAL AXIS MULTISTAGE CENTRIFUGAL PUMPS WITH MCE/P INVERTER

MATERIALS NKV 10-15-20

N.	PARTS	MATERIALS *
1	EXTERNAL PUMP BODY	CATAPHORESIS TREATED CAST IRON
	INTERNAL PUMP BODY*	AISI 304 STAINLESS STEEL
3	SUPPORT	CATAPHORESIS TREATED CAST IRON
4	IMPELLER*	AISI 304 STAINLESS STEEL
6	DIFFUSER*	"ULTEM" TECHNOPOLYMER
7A	PUMP SHAFT*	AISI 431 STAINLESS STEEL
16	MECHANICAL SEAL*	SIC/GRAPHITE/EPDM CARTRIDGE
69	OUTER LINER	AISI 304 STAINLESS STEEL

* In contact with the liquid

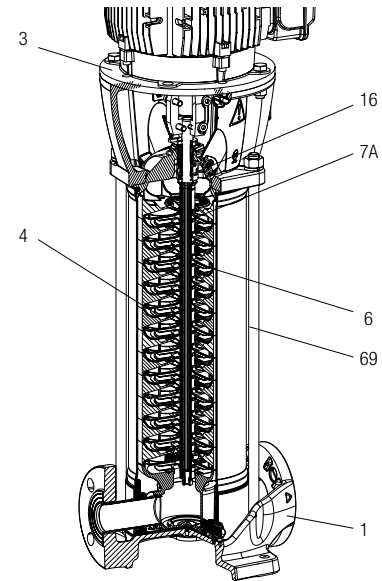

MATERIALS NKV 32-45-65-95

N.	PARTS	MATERIALS *
1	PUMP BODY	CATAPHORESIS TREATED CAST IRON
3	FLANGE	CATAPHORESIS TREATED CAST IRON
4	IMPELLER	AISI 304 STAINLESS STEEL
6	PUMP BODY AND DIFFUSER	AISI 304 STAINLESS STEEL
7A	PUMP SHAFT	AISI 431 STAINLESS STEEL
16	MECHANICAL SEAL	SIC, GRAPHITE, EPDM
26	DISCHARGE CAP	AISI 304 STAINLESS STEEL
28	O-RING	EPDM
36	SEAL RING	AISI 316 STAINLESS STEEL
37	FILLING CAP	AISI 304 STAINLESS STEEL
60	INTERMEDIATE BEARING BUSHING	GRAPHITE
69	OUTER LINER	AISI 304 STAINLESS STEEL
191	FLOATING ADJUSTMENT RING	PTFE
270	GUIDE BUSHING	TUNGSTEN CARBIDE

* In contact with the liquid

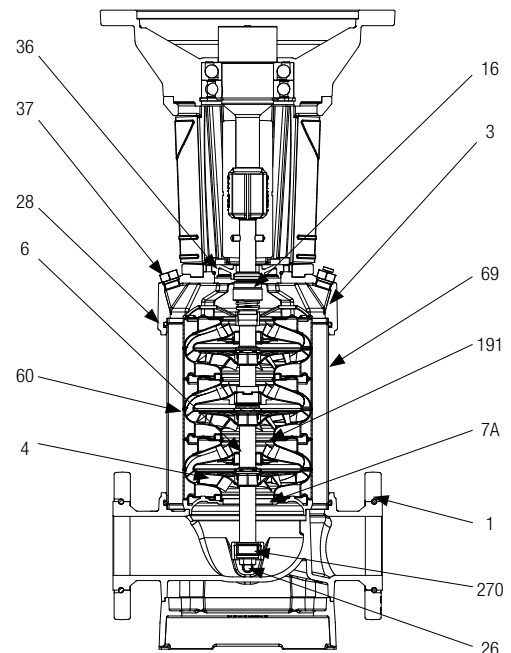

NKVE 10-15-20-32-45-65-95

VERTICAL AXIS MULTISTAGE CENTRIFUGAL PUMPS WITH MCE/P INVERTER

SELECTION TABLE - NKVE 10

MODEL	Q=m ³ /h	0	4	8	10	12
	Q=l/min	0	66	132	167	200
NKVE 10/2 M MCE11/P	H (m)	20,2	20	18,3	15,8	12,5
NKVE 10/3 M MCE11/P		30,3	31	27,5	23,6	18,8
NKVE 10/4 M MCE11/P		40,4	41	36,7	31,5	25,1
NKVE 10/5 M MCE15/P		50,5	51	45,8	39,4	31,3
NKVE 10/6 M MCE15/P		60,5	61	55,0	47,3	37,6
NKVE 10/7 T MCE30/P		70,6	72	64,2	55,1	43,8
NKVE 10/8 T MCE30/P		80,7	82	73,3	63,0	50,1
NKVE 10/9 T MCE30/P		90,8	92	82,5	70,9	56,4
NKVE 10/10 T MCE30/P		100,9	102	91,7	78,8	62,6
NKVE 10/12 T MCE55/P		121,1	123	110,0	94,5	75,2
NKVE 10/14 T MCE55/P		141,3	143	128,3	110,3	87,7
NKVE 10/16 T MCE55/P		161,5	164	146,7	126,0	100,2
NKVE 10/18 T MCE55/P		181,6	184	165,0	141,8	112,7
NKVE 10/20 T MCE55/P		201,8	205	183,3	157,5	125,3
NKVE 10/22 T MCE110/P		222	225	202	173,3	137,8

SELECTION TABLE - NKVE 15

MODEL	Q=m ³ /h	0	4	8	10	12	14	16	18	20	22	24
	Q=l/min	0	66	132	167	200	233	264	300	334	367	400
NKVE 15/2 M MCE15/P	H (m)	27,2	26,7	26	26,1	25,5	24,5	23,2	21,6	19,8	17,4	14,6
NKVE 15/3 T MCE30/P		40,8	40,0	40	39,1	38,3	36,8	34,8	32,5	29,7	26,1	21,9
NKVE 15/4 T MCE30/P		54,4	53,4	53	52,1	51,0	49,0	46,4	43,3	39,6	34,8	29,2
NKVE 15/5 T MCE55/P		68,0	66,7	66	65,2	63,8	61,3	58,1	54,1	49,5	43,5	36,5
NKVE 15/6 T MCE55/P		81,6	80,1	79	78,2	76,5	73,6	69,7	64,9	59,4	52,2	43,8
NKVE 15/7 T MCE55/P		95,2	93,4	92	91,2	89,3	85,8	81,3	75,8	69,3	60,9	51,1
NKVE 15/8 T MCE55/P		108,8	106,8	106	104,3	102,0	98,1	92,9	86,6	79,2	69,6	58,4
NKVE 15/9 T MCE55/P		122,4	120,1	119	117,3	114,8	110,3	104,5	97,4	89,1	78,4	65,7
NKVE 15/10 T MCE110/P		136,0	133,5	132	130,4	127,5	122,6	116,1	108,2	99,0	87,1	73,0
NKVE 15/12 T MCE110/P		163,2	160,2	158	156,4	153,0	147,1	139,3	129,9	118,8	104,5	87,6
NKVE 15/14 T MCE110/P		190,4	186,9	185	182,5	178,5	171,6	162,6	151,5	138,6	121,9	102,2
NKVE 15/16 T MCE110/P		217,6	213,6	211	208,6	204,0	196,1	185,8	173,2	158,4	139,3	116,8
NKVE 15/17 T MCE150/P		231,2	226,9	225	221,6	216,7	208,4	197,4	184	168,3	148	124,1

NKVE 10-15-20-32-45-65-95

VERTICAL AXIS MULTISTAGE CENTRIFUGAL PUMPS WITH MCE/P INVERTER

SELECTION TABLE - NKVE 20

MODEL	Q=m ³ /h	0	4	8	10	12	14	16	18	20	22	24	26	29
	Q=l/min	0	66	132	167	200	233	264	300	334	367	400	433	483
NKVE 20/2 M MCE15/P	H (m)	29,3	28,8	28,8	28,6	28	27,6	26,9	25,9	24,6	22,9	21,2	19,1	15,8
NKVE 20/3 T MCE30/P		43,9	43,2	43,1	42,9	42	41,5	40,4	38,8	36,9	34,4	31,8	28,7	23,6
NKVE 20/4 T MCE55/P		58,6	57,6	57,5	57,2	56	55,3	53,8	51,8	49,2	45,9	42,4	38,2	31,5
NKVE 20/5 T MCE55/P		73,2	71,9	71,9	71,5	71	69,1	67,3	64,7	61,5	57,4	52,9	47,8	39,4
NKVE 20/6 T MCE55/P		87,9	86,3	86,3	85,8	85	82,9	80,7	77,7	73,8	68,8	63,5	57,4	47,3
NKVE 20/7 T MCE55/P		102,5	100,7	100,6	100,1	99	96,8	94,2	90,6	86,1	80,3	74,1	66,9	55,2
NKVE 20/8 T MCE110/P		117,2	115,1	115,0	114,4	113	110,6	107,6	103,6	98,4	91,8	84,7	76,5	63,1
NKVE 20/9 T MCE110/P		131,8	129,5	129,4	128,8	127	124,4	121,1	116,5	110,8	103,2	95,3	86,0	70,9
NKVE 20/10 T MCE110/P		146,5	143,9	143,8	143,1	141	138,2	134,5	129,5	123,1	114,7	105,9	95,6	78,8
NKVE 20/12 T MCE110/P		175,8	172,7	172,5	171,7	169	165,9	161,4	155,4	147,7	137,6	127,1	114,7	94,6
NKVE 20/14 T MCE150/P		205,1	201,4	201,3	200,3	198	193,5	188,3	181,3	172,3	160,6	148,2	133,8	110,4

SELECTION TABLE - NKVE 32

MODEL	Q=m ³ /h	0	15	18	22	25	30	35	40	45
	Q=l/min	0	250	300	367	417	500	583	667	750
NKVE 32/2 T MCE 55/P	H (m)	48,5	43,5	42,5	41	39,5	36,5	33,5	29	23,5
NKVE 32/3-2 T MCE 55/P		60	54,5	53	50,5	48	44	38	31,5	23,5
NKVE 32/3 T MCE 110/P		73	65	63,5	61	59	55	50	43,5	35,5
NKVE 32/4 T MCE 110/P		98	88	86	83	80,5	75	69	60	49,5
NKVE 32/5-2 T MCE 110/P		109,5	99,5	97	93	89,5	83	74	63	49,5
NKVE 32/5 T MCE 150/P		122,5	109,5	107	103,5	100	93,5	85,5	75	61,5
NKVE 32/6 T MCE 150/P		146,5	131	128	123,5	119,5	111,5	102	89	73
NKVE 32/7-2 T MCE 150/P		158	142,5	139	133,5	128,5	119	107	91,5	72,5

SELECTION TABLE - NKVE 45

MODEL	Q=m ³ /h	0	15	18	22	25	30	35	40	45	54	60	65	70
	Q=l/min	0	250	300	367	417	500	583	667	750	900	1000	1083	1166
NKVE 45/2-2 T MCE 55/P	H (m)	38,5	37,5	37	36,5	35,5	34,5	33	31	28,5	23	18,5	14,5	10
NKVE 45/2 T MCE 110/P		48,5	47,5	47	46	45,5	44	43	41,5	39	34	30,5	26,5	23
NKVE 45/3 T MCE 110/P		73,5	72	71	70	69	67	65,5	63	60	52,5	47	41	34
NKVE 45/4 T MCE 150/P		97,5	96	94,5	93	91,5	89	86,5	84	79,5	69,5	62	54,5	45

NKVE 10-15-20-32-45-65-95

VERTICAL AXIS MULTISTAGE CENTRIFUGAL PUMPS WITH MCE/P INVERTER

SELECTION TABLE - NKVE 65

MODEL	Q=m ³ /h	0	30	36	42	45	54	60	72	78	85
	Q=l/min	0	500	600	700	750	900	1000	1200	1300	1417
NKVE 65/2-2 T MCE 110/P	H (m)	39	37,5	36,5	35,5	35	33	31	25	22	17,5
NKVE 65/2 T MCE 110/P		56,5	51	49,5	48,5	48	46	45	41	38,5	34,5
NKVE 65/3-2 T MCE 150/P		67,5	63,5	62	60,5	59,5	56,5	54	46,5	42	35,5

SELECTION TABLE - NKVE 95

MODEL	Q=m ³ /h	0	45	54	60	72	78	85	96	108	118
	Q=l/min	0	750	900	1000	1200	1300	1417	1600	1800	1967
NKVE 95/2-2 T MCE 110/P	H (m)	44,5	43	42	41	38,5	36,5	34	28,5	21,5	15
NKVE 95/2 T MCE 150/P		62	55,5	53	51,5	49	47,5	45	41	35	28,5

NKVE 10 - VERTICAL AXIS MULTISTAGE CENTRIFUGAL PUMPS WITH MCE/P INVERTER FOR PRESSURISATION SYSTEMS

Pumped liquid temperature range: from 15 °C to +80 °C - Maximum ambient temperature: +40 °C - Max flow rate: 13 m³/h

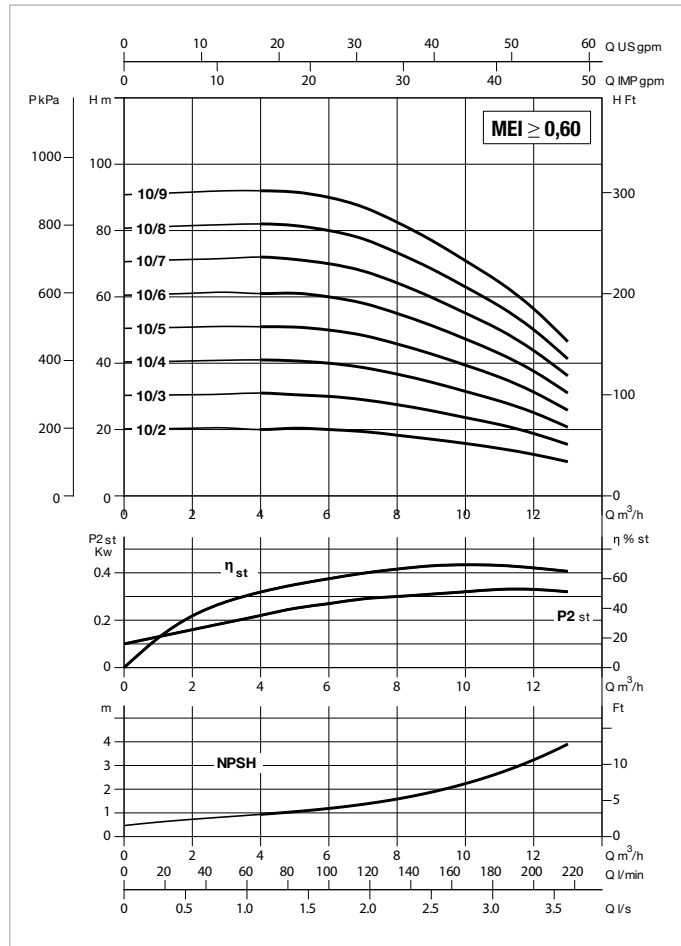
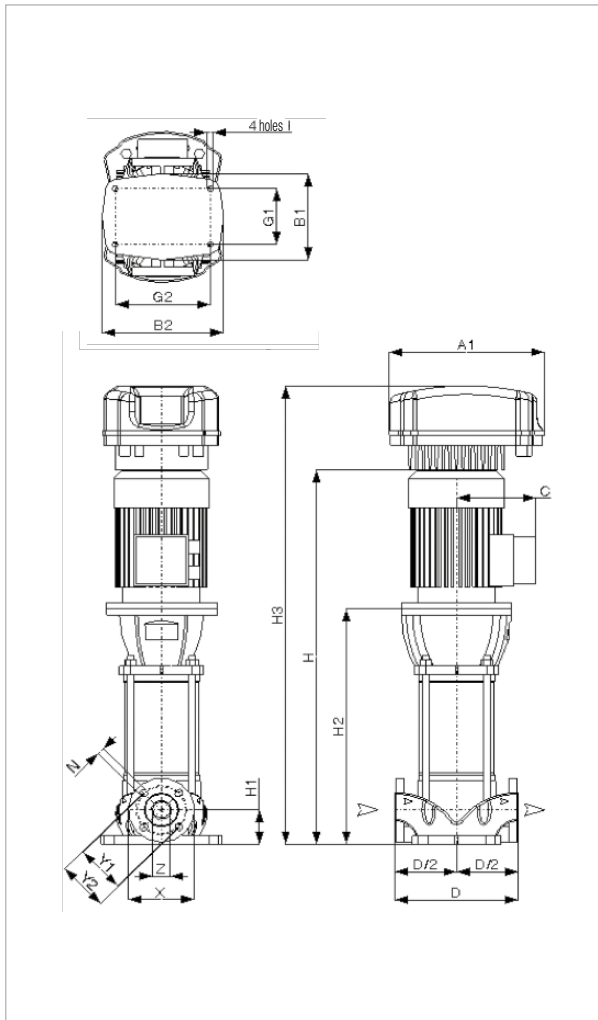

See hydraulic efficiency details on page 241.

The performance curves are based on kinematic viscosity values = 1 mm²/s and density equal to 1000 kg/m³. Curve tolerance according to ISO 9906.

MODEL	POWER INPUT 50 Hz	P2 NOMINAL		In A	r.p.m.
		kW	HP		
NKVE 10/2 M MCE11/P	1 x 230 V ~	0,8	1	7,17	2896
NKVE 10/3 M MCE11/P	1 x 230 V ~	1,1	2	9,92	2888
NKVE 10/4 M MCE11/P	1 x 230 V ~	1,5	2	12,74	2904
NKVE 10/5 M MCE15/P	1 x 230 V ~	2,2	3	15,30	2911
NKVE 10/6 M MCE15/P	1 x 230 V ~	2,2	3	17,51	2890
NKVE 10/7 T MCE30/P	3 x 400 V ~	3,0	4	6,06	2922
NKVE 10/8 T MCE30/P	3 x 400 V ~	3,0	4	6,54	2906
NKVE 10/9 T MCE30/P	3 x 400 V ~	3,0	4	7,13	2886

MODEL	A1	B1	B2	G1	G2	ØI	C	D	D/2	H	H1	H2	H3	DNA=DNM (DN40)					PACKING DIMENSIONS			VOL. m ³	WEIGHT kg
														X	Y1	Y2	Z	N	L/A	L/B	H		
NKVE 10/2 M MCE11/P	262	201	274	130	215	13,5	140	280	140	623,2	80	368,2	823,2	150	110	115	40	17,5	800	400	400	0,128	47,8
NKVE 10/3 M MCE11/P	262	201	274	130	215	13,5	140	280	140	656,2	80	401,2	856,2	150	110	115	40	17,5	960	400	370	0,142	49,3
NKVE 10/4 M MCE11/P	262	201	274	130	215	13,5	160	280	140	704,2	80	434,2	904,2	150	110	115	40	17,5	960	400	370	0,142	54,2
NKVE 10/5 M MCE15/P	262	201	274	130	215	13,5	160	280	140	762,2	80	467,2	962,2	150	110	115	40	17,5	1150	500	400	0,230	59,0
NKVE 10/6 M MCE15/P	262	201	274	130	215	13,5	160	280	140	795,2	80	500,2	995,2	150	110	115	40	17,5	1150	500	400	0,230	59,9
NKVE 10/7 T MCE30/P	352	201	274	130	215	13,5	180	280	140	875,2	80	550,2	1075,2	150	110	115	40	17,5	1150	500	400	0,230	73,3
NKVE 10/8 T MCE30/P	352	201	274	130	215	13,5	180	280	140	908,2	80	583,2	1108,2	150	110	115	40	17,5	1150	500	400	0,230	74,2
NKVE 10/9 T MCE30/P	352	201	274	130	215	13,5	180	280	140	941,2	80	616,2	1141,2	150	110	115	40	17,5	1360	500	530	0,360	75,1

NKVE 10 - VERTICAL AXIS MULTISTAGE CENTRIFUGAL PUMPS WITH MCE/P INVERTER FOR PRESSURISATION SYSTEMS

Pumped liquid temperature range: from 15 °C to +80 °C - Maximum ambient temperature: +40 °C - Max flow rate: 13 m³/h

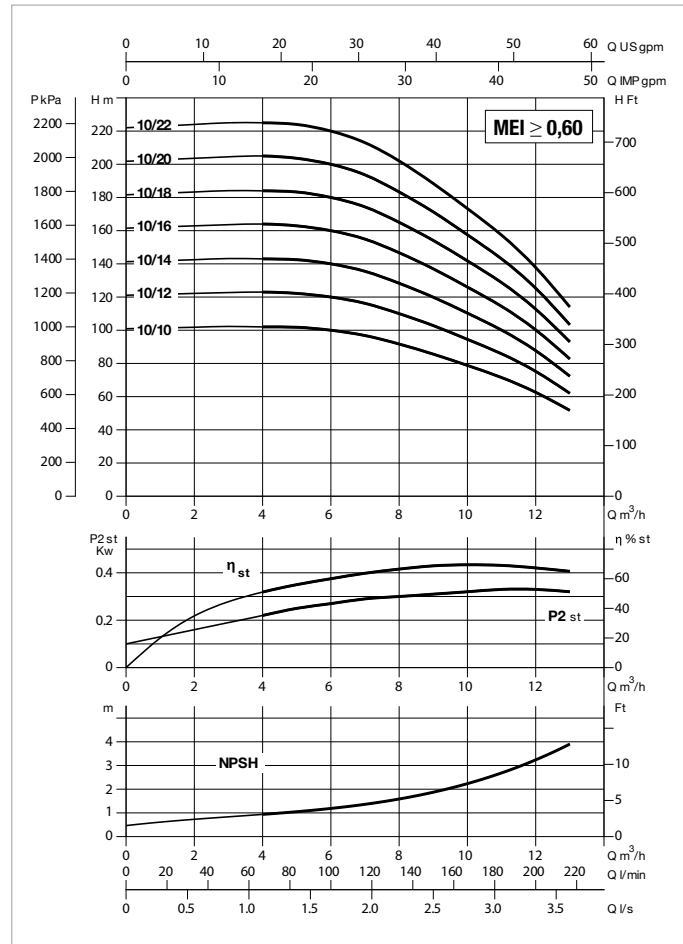
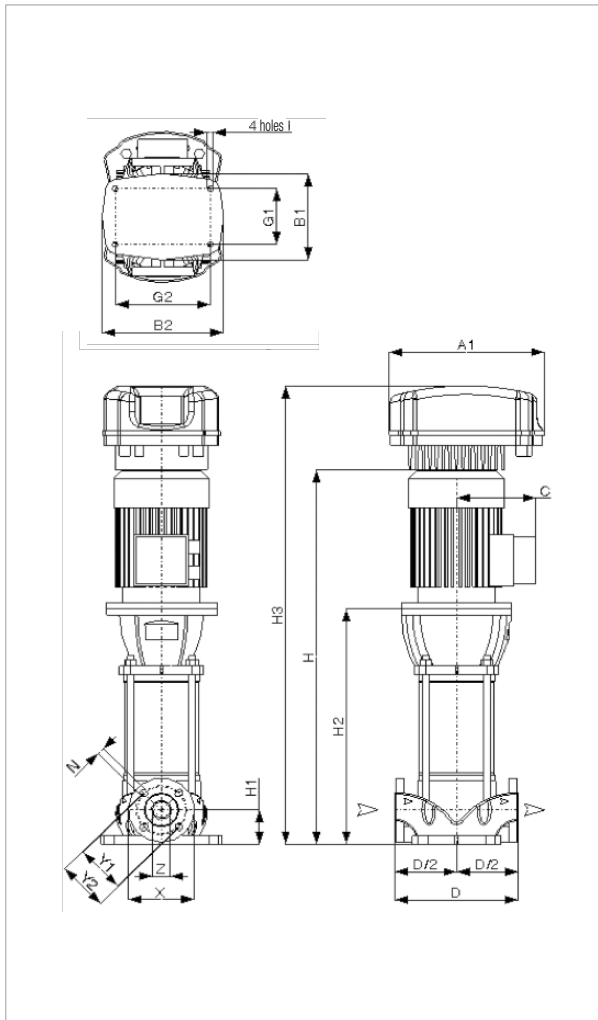

See hydraulic efficiency details on page 241.

The performance curves are based on kinematic viscosity values = 1 mm²/s and density equal to 1000 kg/m³. Curve tolerance according to ISO 9906.

MODEL	POWER INPUT 50 Hz	P2 NOMINAL		In A	r.p.m.
		kW	HP		
NKVE 10/10 T MCE30/P	3 x 400 V ~	4,0	6	8,66	2929
NKVE 10/12 T MCE55/P	3 x 400 V ~	4,0	6	10,08	2911
NKVE 10/14 T MCE55/P	3 x 400 V ~	5,5	8	11,78	2923
NKVE 10/16 T MCE55/P	3 x 400 V ~	5,5	8	13,17	2909
NKVE 10/18 T MCE55/P	3 x 400 V ~	7,5	10	14,72	2922
NKVE 10/20 T MCE55/P	3 x 400 V ~	7,5	10	16,05	2912
NKVE 10/22 T MCE110/P	3 x 400 V ~	7,5	10	17,29	2902

MODEL	A1	B1	B2	G1	G2	ØI	C	D	D/2	H	H1	H2	H3	DNA=DNM (DN40)					PACKING DIMEN- SIONS			VOL. m ³	WEIGHT kg
														X	Y1	Y2	Z	N	L/A	L/B	H		
NKVE 10/10 T MCE30/P	352	201	274	130	215	13,5	190	280	140	989,2	80	649,2	1189,2	150	110	115	40	17,5	1360	500	530	0,360	84,9
NKVE 10/12 T MCE55/P	352	201	274	130	215	13,5	190	280	140	1055,2	80	715,2	1255,2	150	110	115	40	17,5	1360	500	530	0,360	86,5
NKVE 10/14 T MCE55/P	352	201	274	130	215	13,5	210	280	140	1250,6	80	860,6	1450,6	150	110	115	40	17,5	1650	500	580	0,479	115,1
NKVE 10/16 T MCE55/P	352	201	274	130	215	13,5	210	280	140	1316,6	80	926,6	1516,6	150	110	115	40	17,5	1650	500	580	0,479	116,8
NKVE 10/18 T MCE55/P	352	201	274	130	215	13,5	210	280	140	1382,6	80	992,6	1632,6	150	110	115	40	17,5	1850	500	580	0,537	129,6
NKVE 10/20 T MCE55/P	352	201	274	130	215	13,5	210	280	140	1448,6	80	1058,6	1698,6	150	110	115	40	17,5	1850	500	580	0,537	131,2
NKVE 10/22 T MCE110/P	425	201	341	130	215	13,5	210	280	140	1514,6	80	1124,6	1764,6	150	110	115	40	17,5	1850	500	580	0,537	132,9

NKVE 15 - VERTICAL AXIS MULTISTAGE CENTRIFUGAL PUMPS WITH MCE/P INVERTER FOR PRESSURISATION SYSTEMS

Pumped liquid temperature range: from 15 °C to +80 °C - Maximum ambient temperature: +40 °C - Max flow rate: 24 m³/h

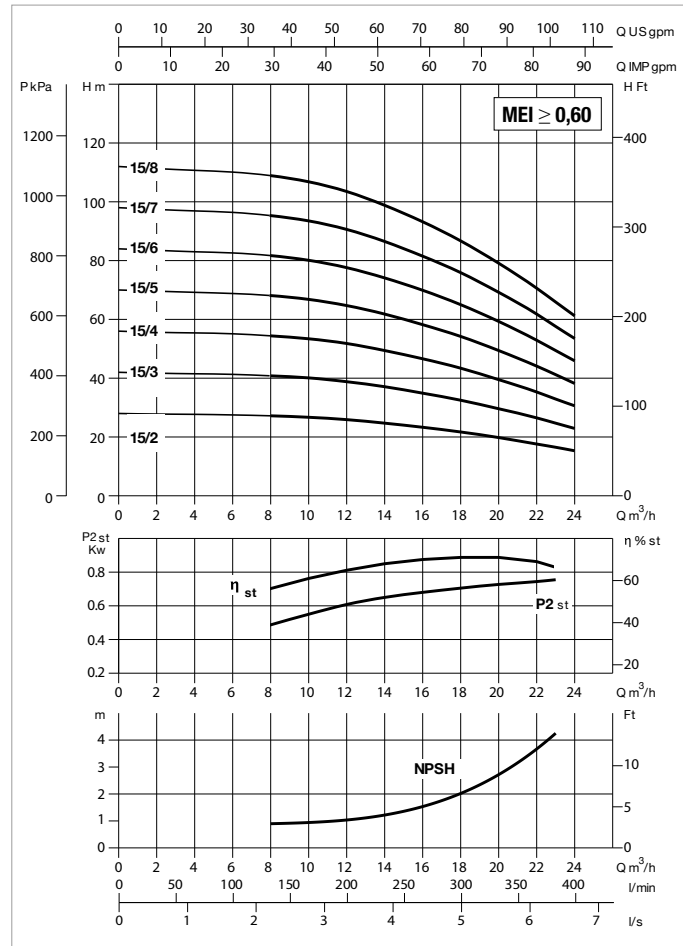
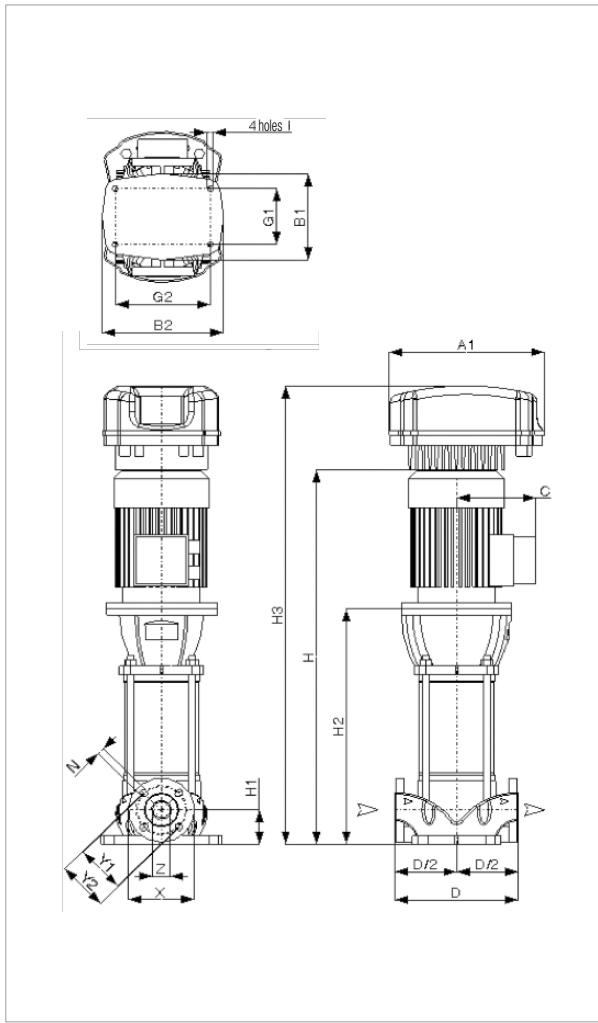

See hydraulic efficiency details on page 241.

The performance curves are based on kinematic viscosity values = 1 mm²/s and density equal to 1000 kg/m³. Curve tolerance according to ISO 9906.

MODEL	POWER INPUT 50 Hz	P2 NOMINAL		In A	r.p.m.
		kW	HP		
NKVE 15/2 M MCE15/P	1 x 230 V ~	2,2	3	14,49	2919
NKVE 15/3 T MCE30/P	3 x 400 V ~	3,0	4	6,06	2922
NKVE 15/4 T MCE30/P	3 x 400 V ~	4,0	6	7,95	2938
NKVE 15/5 T MCE55/P	3 x 400 V ~	4,0	6	9,77	2915
NKVE 15/6 T MCE55/P	3 x 400 V ~	5,5	8	10,97	2932
NKVE 15/7 T MCE55/P	3 x 400 V ~	5,5	8	12,84	2912
NKVE 15/8 T MCE55/P	3 x 400 V ~	7,5	10	14,74	2922

MODEL	A1	B1	B2	G1	G2	ØI	C	D	D/2	H	H1	H2	H3	DNA=DNM (DN40)					PACKING DIMEN-SIONS			VOL. m ³	WEIGHT kg
														X	Y1	Y2	Z	N	L/A	L/B	H		
NKVE 15/2 M MCE15/P	262	201	274	130	215	13,5	160	300	150	717,9	90	422,9	917,9	165	125	-	67	18	960	400	370	0,142	59,1
NKVE 15/3 T MCE30/P	352	201	274	130	215	13,5	180	300	150	814,4	90	489,4	1014,4	165	125	-	67	18	1150	500	400	0,230	72,5
NKVE 15/4 T MCE30/P	352	201	274	130	215	13,5	190	300	150	878,9	90	538,9	1078,9	165	125	-	67	18	1150	500	400	0,230	82,7
NKVE 15/5 T MCE55/P	352	201	274	130	215	13,5	190	300	150	928,4	90	588,4	1128,4	165	125	-	67	18	1360	500	530	0,360	84,0
NKVE 15/6 T MCE55/P	352	201	274	130	215	13,5	210	300	150	1107,3	90	717,3	1307,3	165	125	-	67	18	1360	500	530	0,360	112,2
NKVE 15/7 T MCE55/P	352	201	274	130	215	13,5	210	300	150	1156,8	90	766,8	1356,8	165	125	-	67	18	1650	500	580	0,479	113,4
NKVE 15/8 T MCE55/P	352	201	274	130	215	13,5	210	300	150	1206,3	90	816,3	1456,3	165	125	-	67	18	1650	500	580	0,479	125,7

NKVE 15 - VERTICAL AXIS MULTISTAGE CENTRIFUGAL PUMPS WITH MCE/P INVERTER FOR PRESSURISATION SYSTEMS

Pumped liquid temperature range: from 15 °C to +80 °C - Maximum ambient temperature: +40 °C - Max flow rate: 24 m³/h

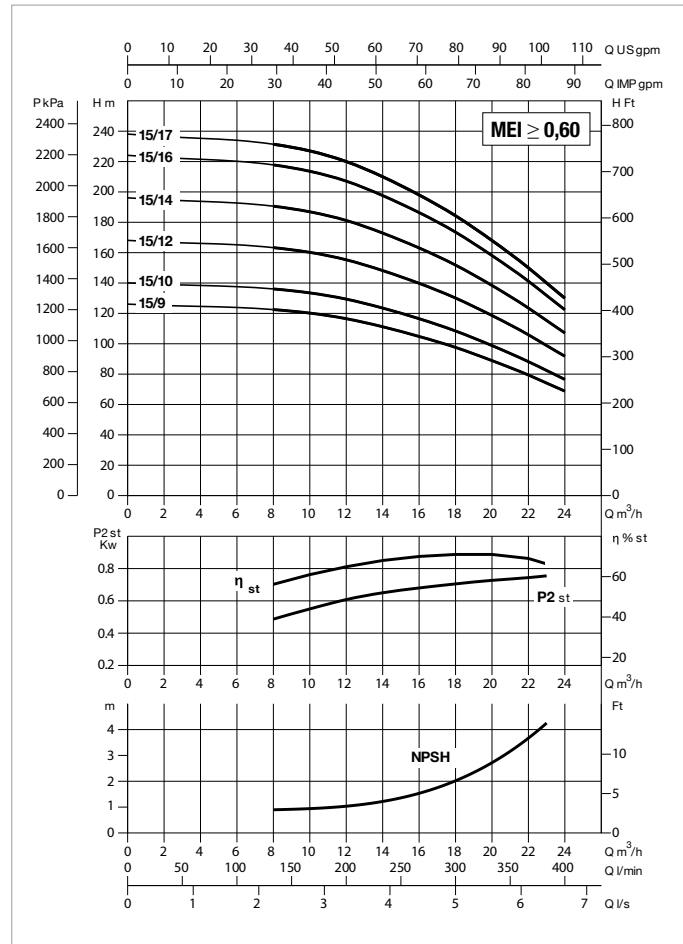
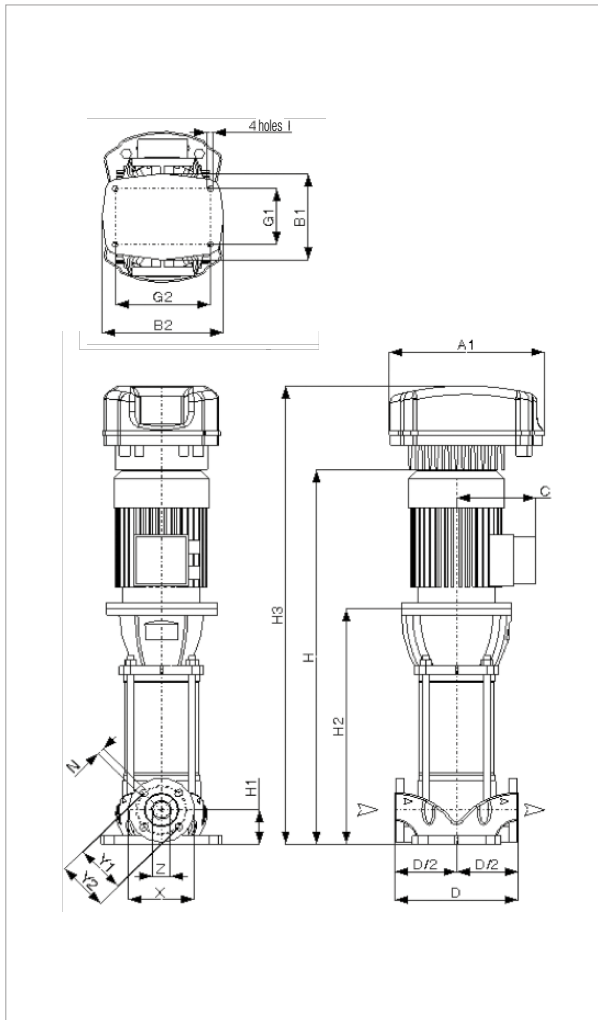

See hydraulic efficiency details on page 241.

The performance curves are based on kinematic viscosity values = 1 mm²/s and density equal to 1000 kg/m³. Curve tolerance according to ISO 9906.

MODEL	POWER INPUT 50 Hz	P2 NOMINAL		ln A	r.p.m.
		kW	HP		
NKVE 15/9 T MCE55/P	3 x 400 V ~	7,5	10	16,30	2910
NKVE 15/10 T MCE110/P	3 x 400 V ~	11,0	15	18,82	2952
NKVE 15/12 T MCE110/P	3 x 400 V ~	11,0	15	21,94	2941
NKVE 15/14 T MCE110/P	3 x 400 V ~	11,0	15	25,04	2931
NKVE 15/16 T MCE110/P	3 x 400 V ~	15,0	20	29,13	2953
NKVE 15/17 T MCE150/P	3 x 400 V ~	15,0	20	30,54	2949

MODEL	A1	B1	B2	G1	G2	Ø1	C	D	D/2	H	H1	H2	H3	DNA=DNM (DN40)					PACKING DIMEN- SIONS			VOL. m ³	WEIGHT kg
														X	Y1	Y2	Z	N	L/A	L/B	H		
NKVE 15/9 T MCE55/P	352	201	274	130	215	13,5	210	300	150	1255,8	90	865,8	1505,8	165	125	-	67	18	1650	500	580	0,479	127,0
NKVE 15/10 T MCE110/P	425	201	341	130	215	13,5	248	300	150	1449,5	90	944,5	1699,5	165	125	-	67	18	1850	500	580	0,537	183,2
NKVE 15/12 T MCE110/P	425	201	341	130	215	13,5	248	300	150	1548,5	90	1043,5	1798,5	165	125	-	67	18	1850	500	580	0,537	185,7
NKVE 15/14 T MCE110/P	425	201	341	130	215	13,5	248	300	150	1647,5	90	1142,5	1897,5	165	125	-	67	18	2050	500	580	0,595	188,2
NKVE 15/16 T MCE110/P	425	201	341	130	215	13,5	248	300	150	1746,5	90	1241,5	1996,5	165	125	-	67	18	2050	500	580	0,595	198,7
NKVE 15/17 T MCE150/P	425	201	341	130	215	13,5	248	300	150	1796	90	1291	2046	165	125	-	67	18	2050	500	580	0,595	199,9

NKVE 20 - VERTICAL AXIS MULTISTAGE CENTRIFUGAL PUMPS WITH MCE/P INVERTER FOR PRESSURIZATION SYSTEMS

Pumped liquid temperature range: from 15 °C to +80 °C - Maximum ambient temperature: +40 °C - Max flow rate: 29 m³/h

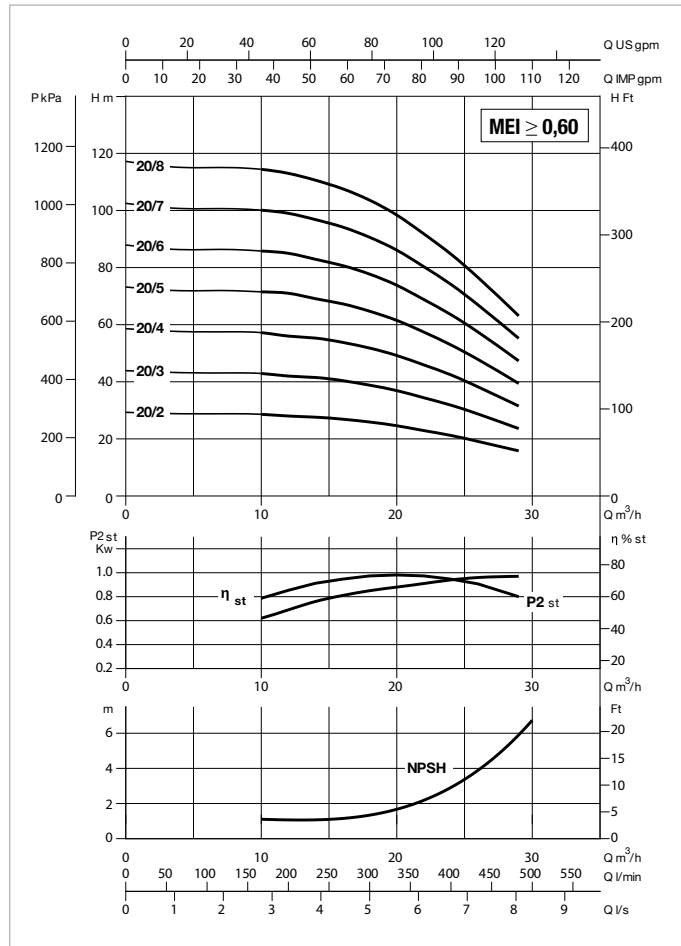
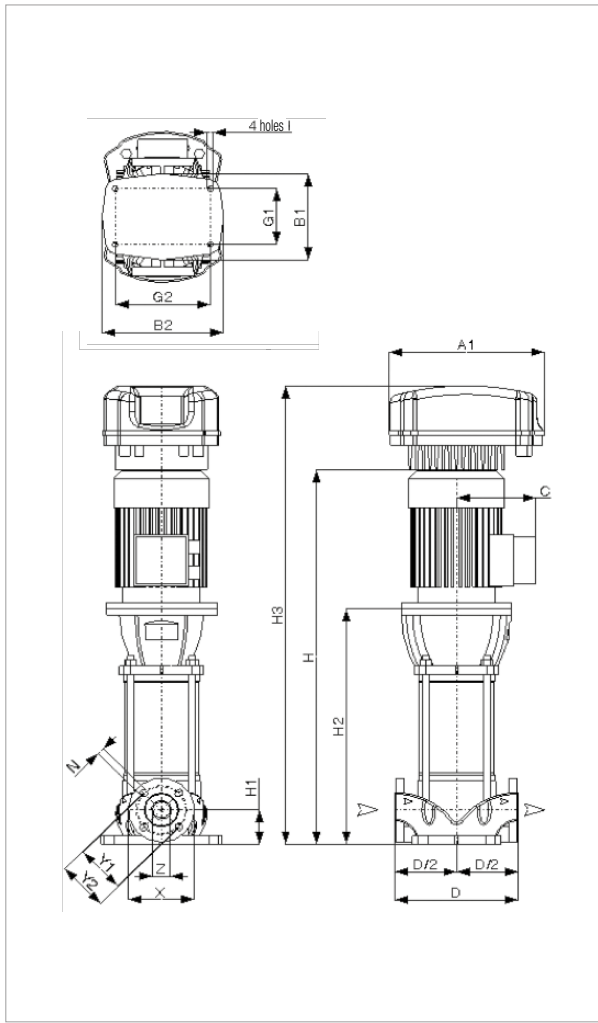

See hydraulic efficiency details on page 241.

The performance curves are based on kinematic viscosity values = 1 mm²/s and density equal to 1000 kg/m³. Curve tolerance according to ISO 9906.

MODEL	POWER INPUT 50 Hz	P2 NOMINAL		In A	r.p.m.
		kW	HP		
NKVE 20/2 M MCE15/P	1 x 230 V ~	2,2	3	17,58	2889
NKVE 20/3 T MCE30/P	3 x 400 V ~	4,0	6	7,81	2940
NKVE 20/4 T MCE55/P	3 x 400 V ~	5,5	8	10,26	2939
NKVE 20/5 T MCE55/P	3 x 400 V ~	5,5	8	11,68	2924
NKVE 20/6 T MCE55/P	3 x 400 V ~	7,5	10	14,38	2925
NKVE 20/7 T MCE55/P	3 x 400 V ~	7,5	10	16,07	2911
NKVE 20/8 T MCE110/P	3 x 400 V ~	11,0	15	19,13	2951

MODEL	A1	B1	B2	G1	G2	ØI	C	D	D/2	H	H1	H2	H3	DNA=DNM (DN40)					PACKING DIMEN- SIONS			VOL. m ³	WEIGHT kg
														X	Y1	Y2	Z	N	L/A	L/B	H		
NKVE 20/2 M MCE15/P	262	201	274	130	215	13,5	160	300	150	717,9	90	422,9	917,9	165	125	-	67	18	960	400	370	0,142	49,4
NKVE 20/3 T MCE30/P	352	201	274	130	215	13,5	190	300	150	829,4	90	489,4	1029,4	165	125	-	67	18	1150	500	400	0,230	67,8
NKVE 20/4 T MCE55/P	352	201	274	130	215	13,5	210	300	150	1008,3	90	618,3	1208,3	165	125	-	67	18	1360	500	530	0,360	81,8
NKVE 20/5 T MCE55/P	352	201	274	130	215	13,5	210	300	150	1057,8	90	667,8	1257,8	165	125	-	67	18	1360	500	530	0,360	83,8
NKVE 20/6 T MCE55/P	352	201	274	130	215	13,5	210	300	150	1107,3	90	717,3	1357,3	165	125	-	67	18	1650	500	580	0,479	95,9
NKVE 20/7 T MCE55/P	352	201	274	130	215	13,5	210	300	150	1156,8	90	766,8	1406,8	165	125	-	67	18	1650	500	580	0,479	96,9
NKVE 20/8 T MCE110/P	425	201	341	130	215	13,5	248	300	150	1350,5	90	845,5	1600,5	165	125	-	67	18	1650	500	580	0,479	128,9

NKVE 20 - VERTICAL AXIS MULTISTAGE CENTRIFUGAL PUMPS WITH MCE/P INVERTER FOR PRESSURISATION SYSTEMS

Pumped liquid temperature range: from 15 °C to +80 °C - Maximum ambient temperature: +40 °C - Max flow rate: 29 m³/h

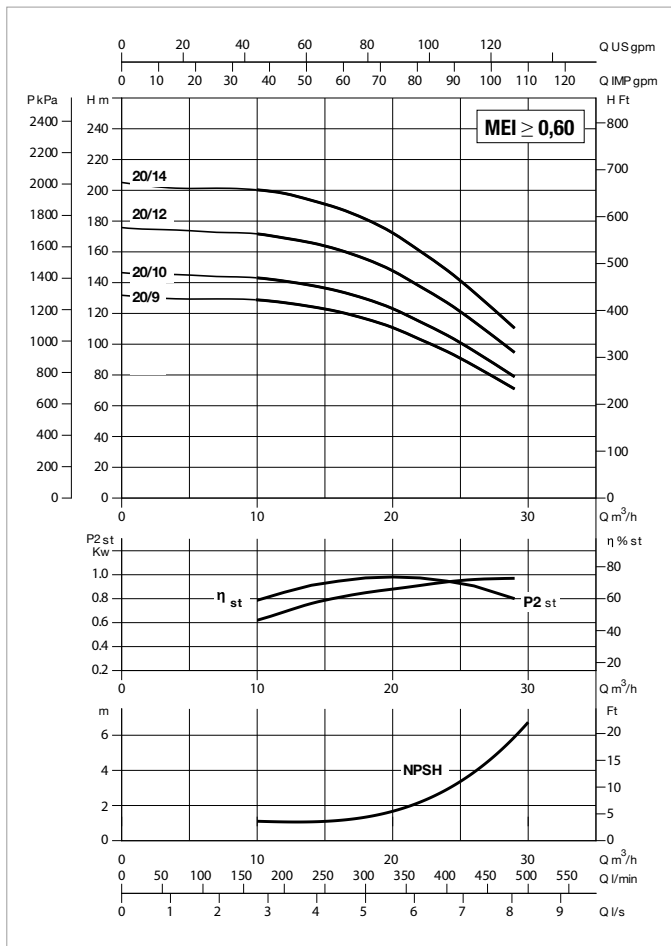
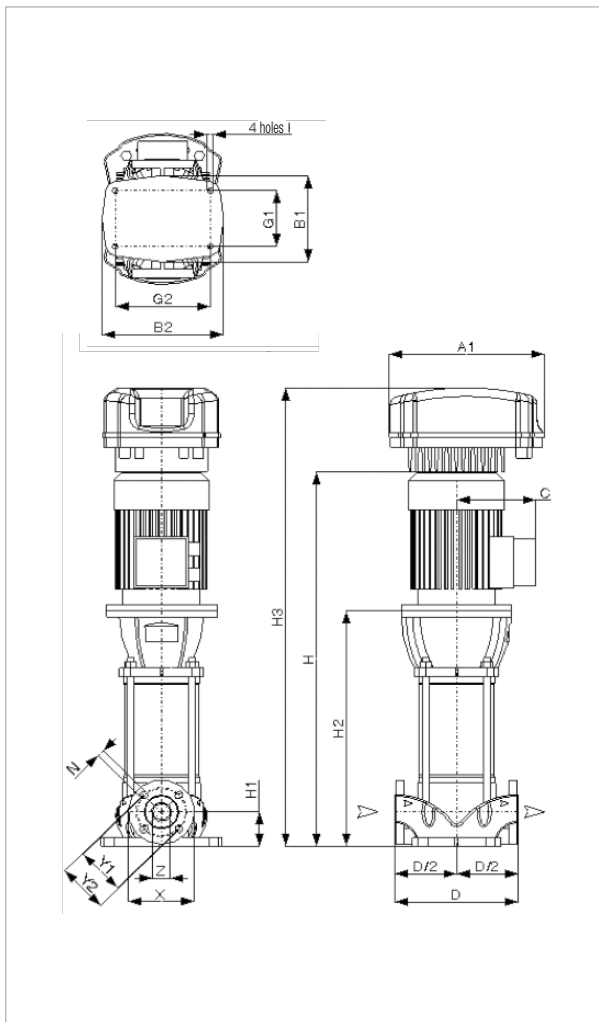

See hydraulic efficiency details on page 241.

The performance curves are based on kinematic viscosity values = 1 mm²/s and density equal to 1000 kg/m³. Curve tolerance according to ISO 9906.

MODEL	POWER INPUT 50 Hz	P2 NOMINAL		In A	r.p.m.
		kW	HP		
NKVE 20/9 T MCE110/P	3 x 400 V ~	11,0	15	20,74	2945
NKVE 20/10 T MCE110/P	3 x 400 V ~	11,0	15	23,26	2937
NKVE 20/12 T MCE110/P	3 x 400 V ~	15,0	20	27,87	2956
NKVE 20/14 T MCE150/P	3 x 400 V ~	15,0	20	31,97	2945

MODEL	A1	B1	B2	G1	G2	Ø1	C	D	D/2	H	H1	H2	H3	DNA=DNM (DN40)					PACKING DIMEN- SIONS			VOL. m ³	WEIGHT kg
														X	Y1	Y2	Z	N	L/A	L/B	H		
NKVE 20/9 T MCE110/P	425	201	341	130	215	13,5	248	300	150	1400	90	895	1650	165	125	-	67	18	1850	500	580	0,537	129,9
NKVE 20/10 T MCE110/P	425	201	341	130	215	13,5	248	300	150	1449,5	90	944,5	1699,5	165	125	-	67	18	1850	500	580	0,537	140,9
NKVE 20/12 T MCE110/P	425	201	341	130	215	13,5	248	300	150	1548,5	90	1043,5	1798,5	165	125	-	67	18	1850	500	580	0,537	153,9
NKVE 20/14 T MCE150/P	425	201	341	130	215	13,5	248	300	150	1647,5	90	1142,5	1897,5	165	125	-	67	18	2050	500	580	0,595	155,9

NKVE 32 - VERTICAL AXIS MULTISTAGE CENTRIFUGAL PUMPS WITH MCE/P INVERTER FOR PRESSURISATION SYSTEMS

Pumped liquid temperature range: from 15 °C to +80 °C - Maximum ambient temperature: +40 °C - Max flow rate: 46 m³/h

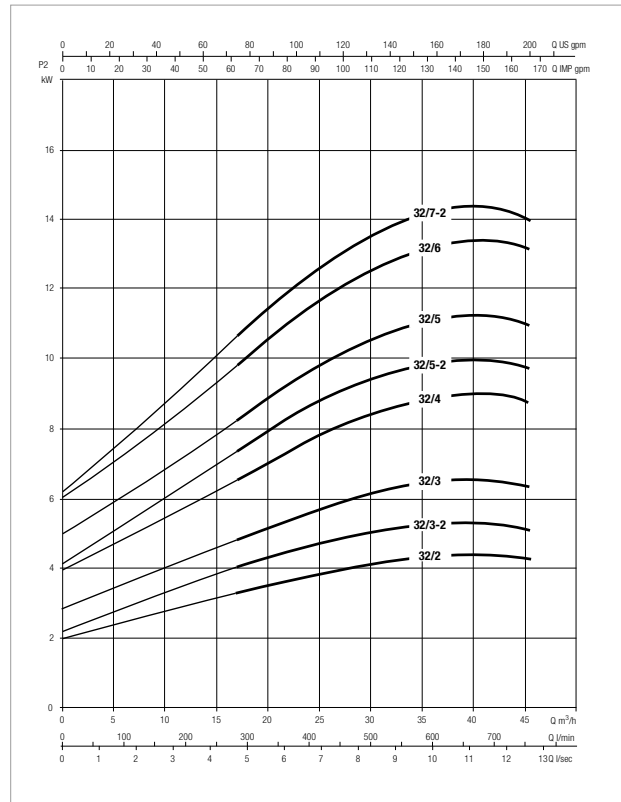
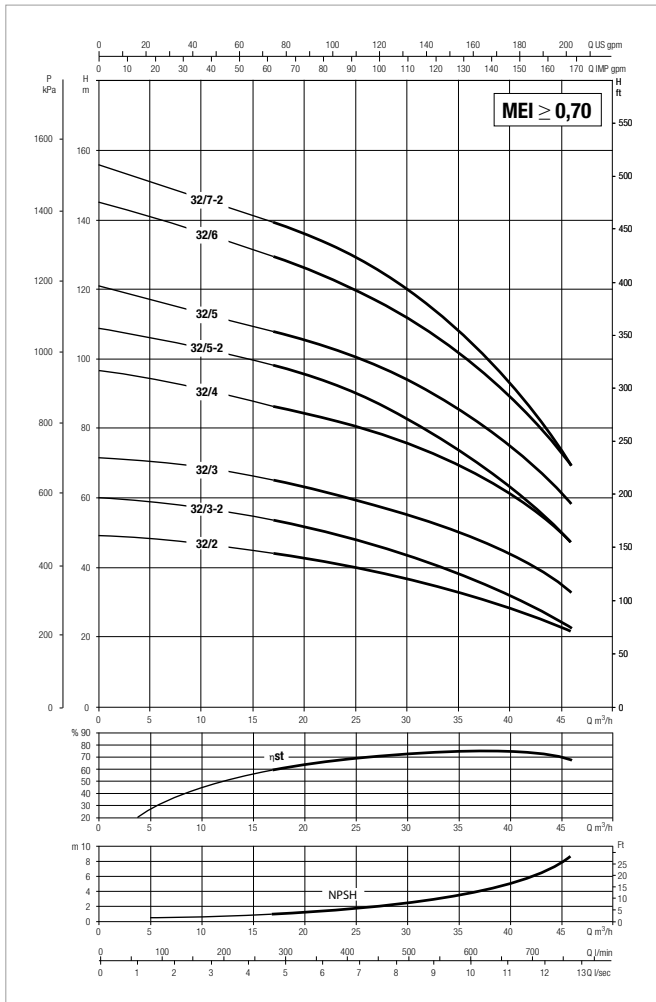

See hydraulic efficiency details on page 241.

The performance curves are based on kinematic viscosity values = 1 mm²/s and density equal to 1000 kg/m³. Curve tolerance according to ISO 9906.

MODEL	POWER INPUT 50 Hz	P2 NOMINAL		In A	r.p.m.
		kW	HP		
NKVE 32/2 T MCE 55/P	3 x 400 V ~	5,5	7,5	13,1	2889
NKVE 32/3-2 T MCE 55/P	3 x 400 V ~	5,5	7,5	13,1	2940
NKVE 32/3 T MCE 110/P	3 x 400 V ~	7,5	10	17,6	2939
NKVE 32/4 T MCE 110/P	3 x 400 V ~	11	15	25,5	2924
NKVE 32/5-2 T MCE 110/P	3 x 400 V ~	11	15	25,5	2925
NKVE 32/5 T MCE 150/P	3 x 400 V ~	15	20	34	2911
NKVE 32/6 T MCE 150/P	3 x 400 V ~	15	20	34	2951
NKVE 32/7-2 T MCE 150/P	3 x 400 V ~	15	20	34	2945

NKVE 32 - VERTICAL AXIS MULTISTAGE CENTRIFUGAL PUMPS WITH MCE/P INVERTER FOR PRESSURISATION SYSTEMS

Pumped liquid temperature range: from 15 °C to +80 °C - Maximum ambient temperature: +40 °C - Max flow rate: 46 m³/h

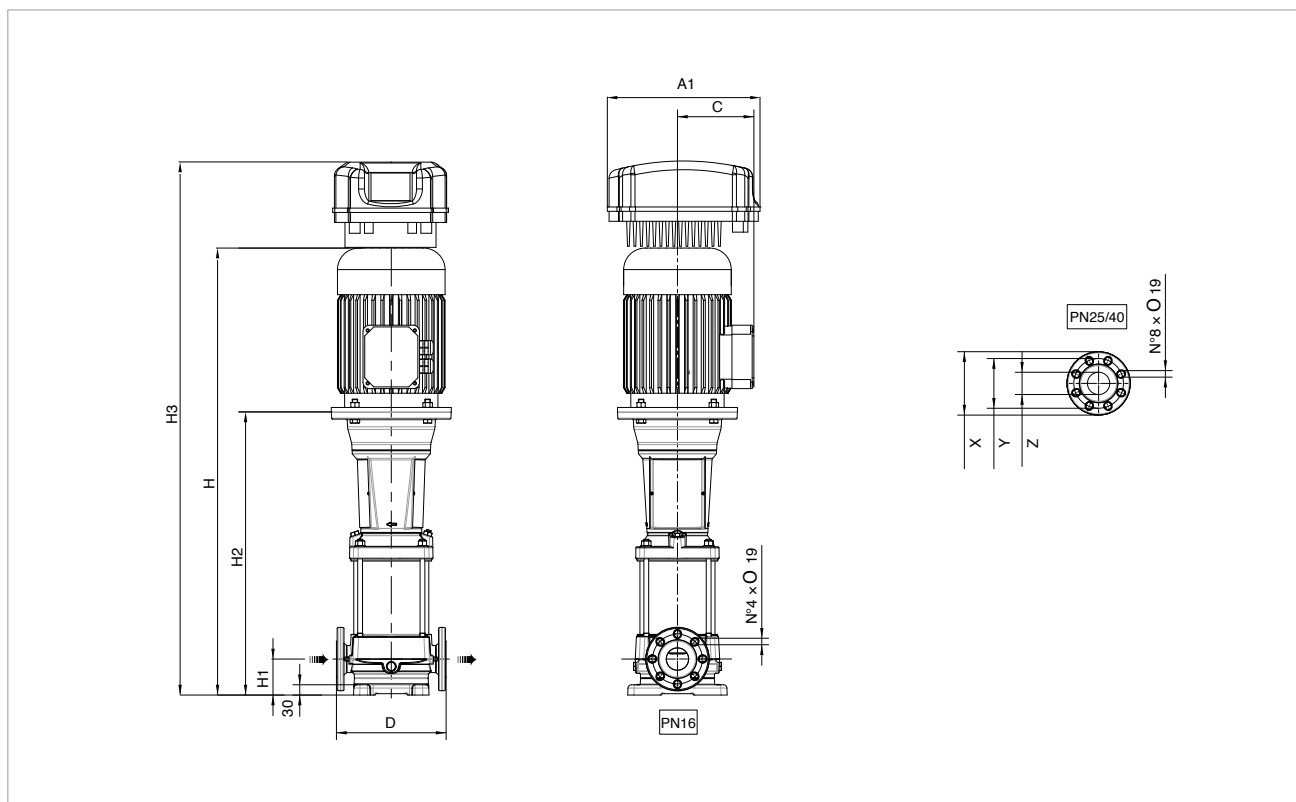

MODEL	N. OF STAGES	A1	C	D	H	H1	H2	H3	DNA = DNM (DN 65)			PACKING DIMENSIONS			VOL. m ³	WEIGHT kg
									X	Y	Z	L/A	L/B	H		
NKVE 32/2 T MCE 55/P	2	352	161	320	1115	105	724	1311	185	145	65	1820	500	630	0,58	148
NKVE 32/3-2 T MCE 55/P	3	352	161	320	1196	105	806	1392	185	145	65	1820	500	630	0,58	152
NKVE 32/3 T MCE 110/P	3	425	161	320	1196	105	806	1440	185	145	65	1820	500	630	0,58	163
NKVE 32/4 T MCE 110/P	4	425	198	320	1413	105	908	1657	185	145	65	1820	500	630	0,58	218
NKVE 32/5-2 T MCE 110/P	5	425	198	320	1495	105	990	1739	185	145	65	1820	500	630	0,58	222
NKVE 32/5 T MCE 150/P	5	425	198	320	1495	105	990	1739	185	145	65	1820	500	630	0,58	236
NKVE 32/6 T MCE 150/P	6	425	198	320	1577	105	1072	1821	185	145	65	2520	500	750	0,95	240
NKVE 32/7-2 T MCE 150/P	7	425	198	320	1659	105	1154	1903	185	145	65	2520	500	750	0,95	244

NKVE 45 - VERTICAL AXIS MULTISTAGE CENTRIFUGAL PUMPS WITH MCE/P INVERTER FOR PRESSURISATION SYSTEMS

Pumped liquid temperature range: from 15 °C to +80 °C - Maximum ambient temperature: +40 °C - Max flow rate: 70 m³/h

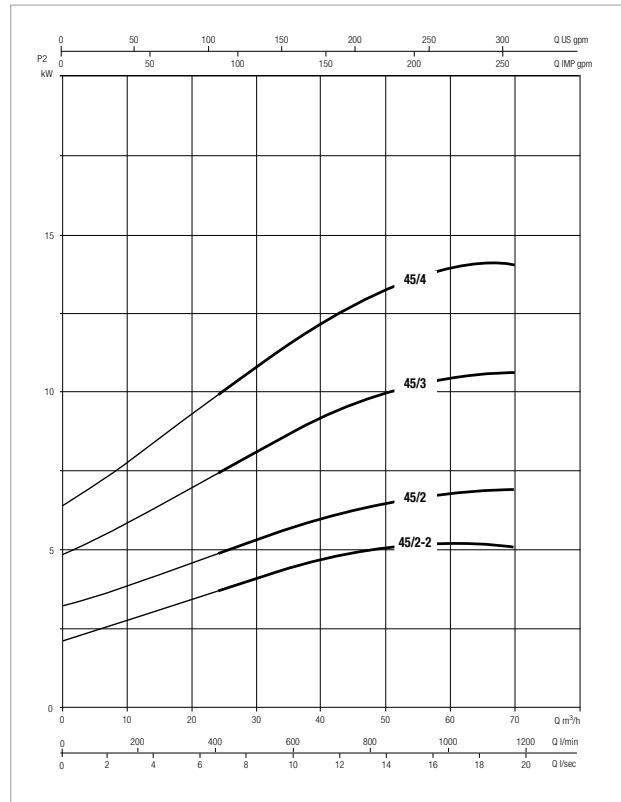
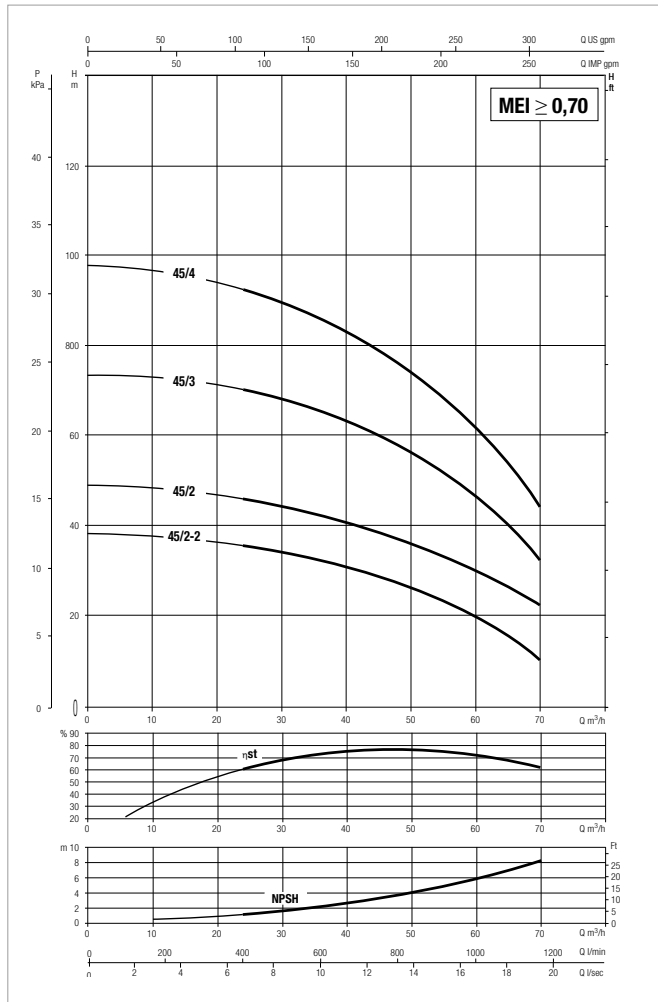

See hydraulic efficiency details on page 241.

The performance curves are based on kinematic viscosity values = 1 mm²/s and density equal to 1000 kg/m³. Curve tolerance according to ISO 9906.

MODEL	POWER INPUT 50 Hz	P2 NOMINAL		I _n A	r.p.m.
		kW	HP		
NKVE 45/2-2 T MCE 55/P	3 x 400 V ~	5,5	7,5	13,1	2980
NKVE 45/2 T MCE 110/P	3 x 400 V ~	7,5	10	17,6	2980
NKVE 45/3 T MCE 110/P	3 x 400 V ~	11	15	25,5	2980
NKVE 45/4 T MCE 150/P	3 x 400 V ~	15	20	34	2980

NKVE 45 - VERTICAL AXIS MULTISTAGE CENTRIFUGAL PUMPS WITH MCE/P INVERTER FOR PRESSURISATION SYSTEMS

Pumped liquid temperature range: from 15 °C to +80 °C - Maximum ambient temperature: +40 °C - Max flow rate: 70 m³/h

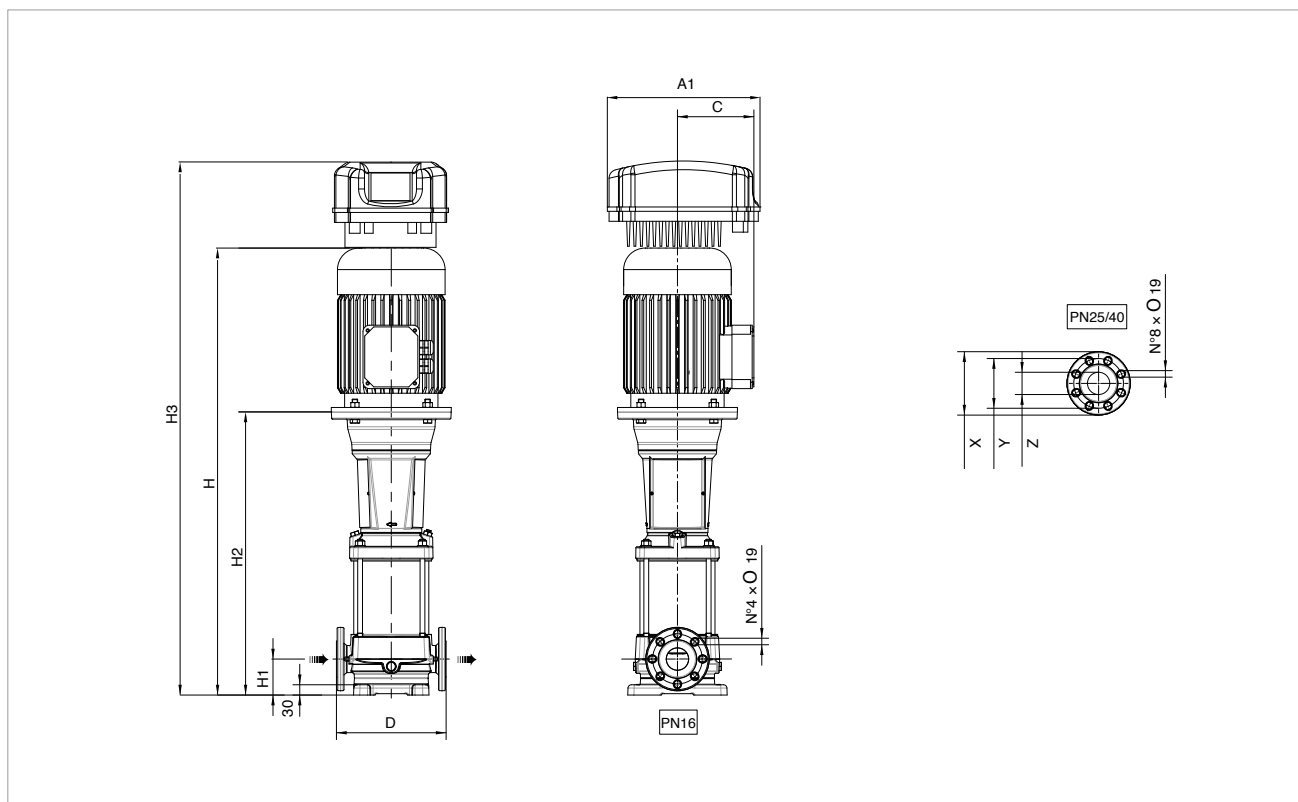

MODEL	N. OF STAGES	A1	C	D	H	H1	H2	H3	DNA = DNM (DN 65)			PACKING DIMENSIONS			VOL. m ³	WEIGHT kg
									X	Y	Z	L/A	L/B	H		
NKVE 45/2-2 T MCE 55/P	2	352	161	365	1149	140	759	1345	200	160	80	1820	500	630	0,58	154
NKVE 45/2 T MCE 110/P	2	425	161	365	1149	140	759	1393	200	160	80	1820	500	630	0,58	165
NKVE 45/3 T MCE 110/P	3	425	198	365	1366	140	861	1610	200	160	80	1820	500	630	0,58	220
NKVE 45/4 T MCE 150/P	4	425	198	365	1448	140	943	1692	200	160	80	1820	500	630	0,58	238

NKVE 65 - VERTICAL AXIS MULTISTAGE CENTRIFUGAL PUMPS WITH MCE/P INVERTER FOR PRESSURISATION SYSTEMS

Pumped liquid temperature range: from 15 °C to +80 °C - Maximum ambient temperature: +40 °C - Max flow rate: 88 m³/h

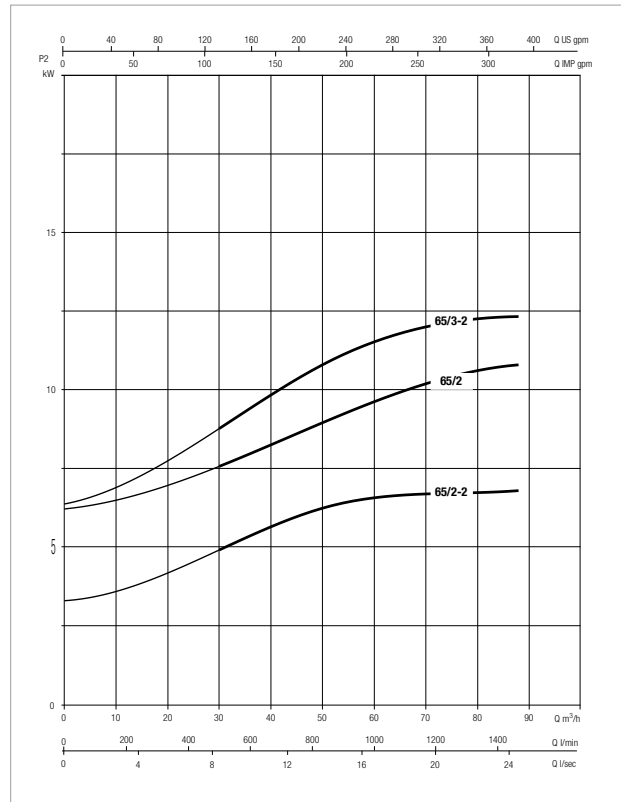
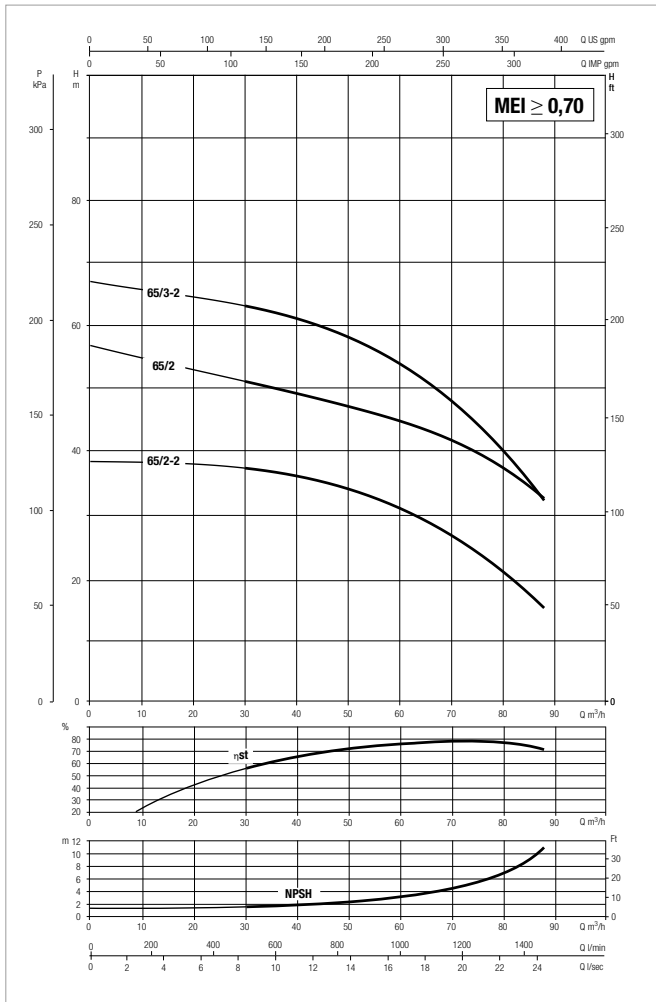

See hydraulic efficiency details on page 241.

The performance curves are based on kinematic viscosity values = 1 mm²/s and density equal to 1000 kg/m³. Curve tolerance according to ISO 9906.

MODEL	POWER INPUT 50 Hz	P2 NOMINAL		In A	r.p.m.
		kW	HP		
NKVE 65/2-2 T MCE 110/P	3 x 400 V ~	7,5	10	17,6	2900
NKVE 65/2 T MCE 110/P	3 x 400 V ~	11	15	25,5	2930
NKVE 65/3-2 T MCE 150/P	3 x 400 V ~	15	20	34	2940

NKVE 65 - VERTICAL AXIS MULTISTAGE CENTRIFUGAL PUMPS WITH MCE/P INVERTER FOR PRESSURISATION SYSTEMS

Pumped liquid temperature range: from 15 °C to +80 °C - Maximum ambient temperature: +40 °C - Max flow rate: 88 m³/h

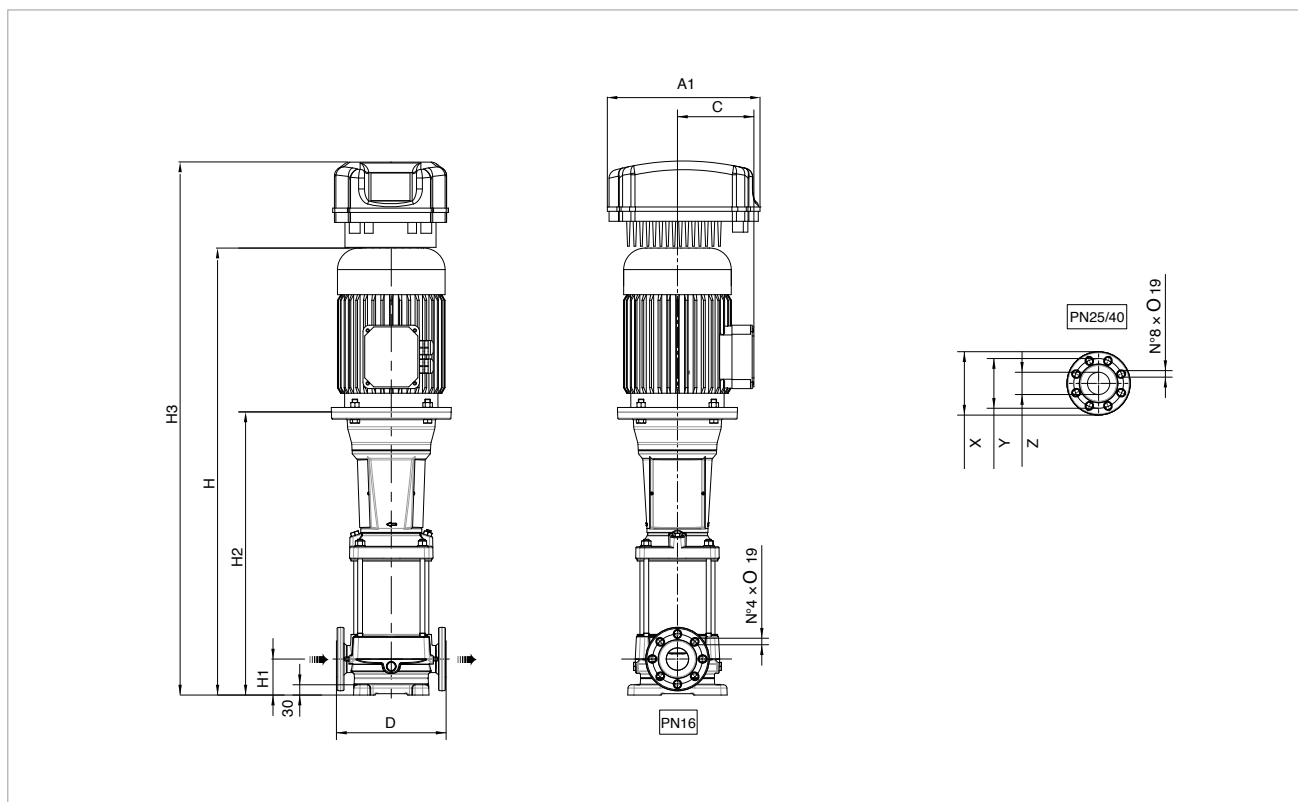

MODEL	N. OF STAGES	A1	C	D	H	H1	H2	H3	DNA = DNM (DN 100)			PACKING DIMENSIONS			VOL. m ³	WEIGHT kg
									X	Y	Z	L/A	L/B	H		
NKVE 65/2-2 T MCE 110/P	2	425	161	365	1266,2	140	829,2	1484,2	230	180	100	1820	500	630	0,58	169,5
NKVE 65/2 T MCE 110/P	2	425	198	365	1354,2	140	849,2	1619,2	230	180	100	1820	500	630	0,58	220,5
NKVE 65/3-2 T MCE 150/P	3	425	198	365	1446,3	140	941,3	1711,3	230	180	100	1820	500	630	0,58	239

NKVE 95 - VERTICAL AXIS MULTISTAGE CENTRIFUGAL PUMPS WITH MCE/P INVERTER FOR PRESSURISATION SYSTEMS

Pumped liquid temperature range: from 15 °C to +80 °C - Maximum ambient temperature: +40 °C - Max flow rate: 118 m³/h

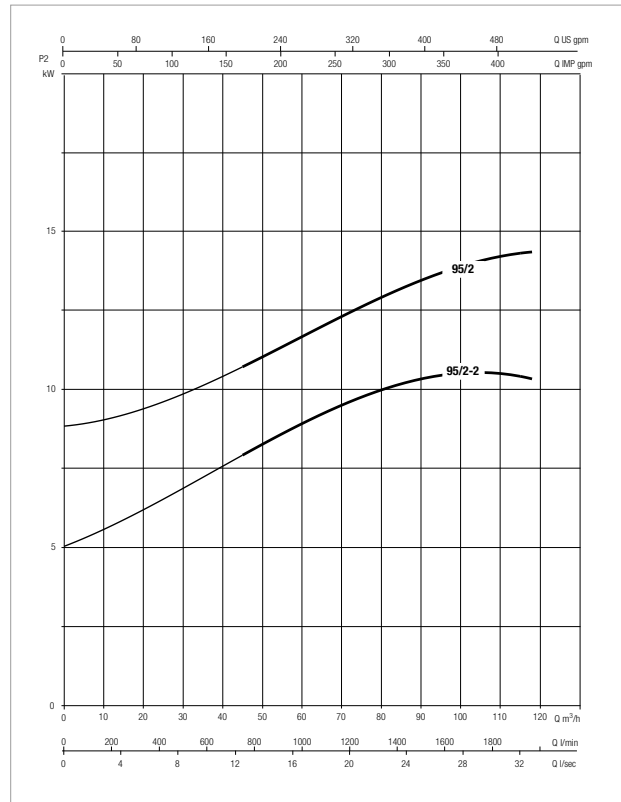
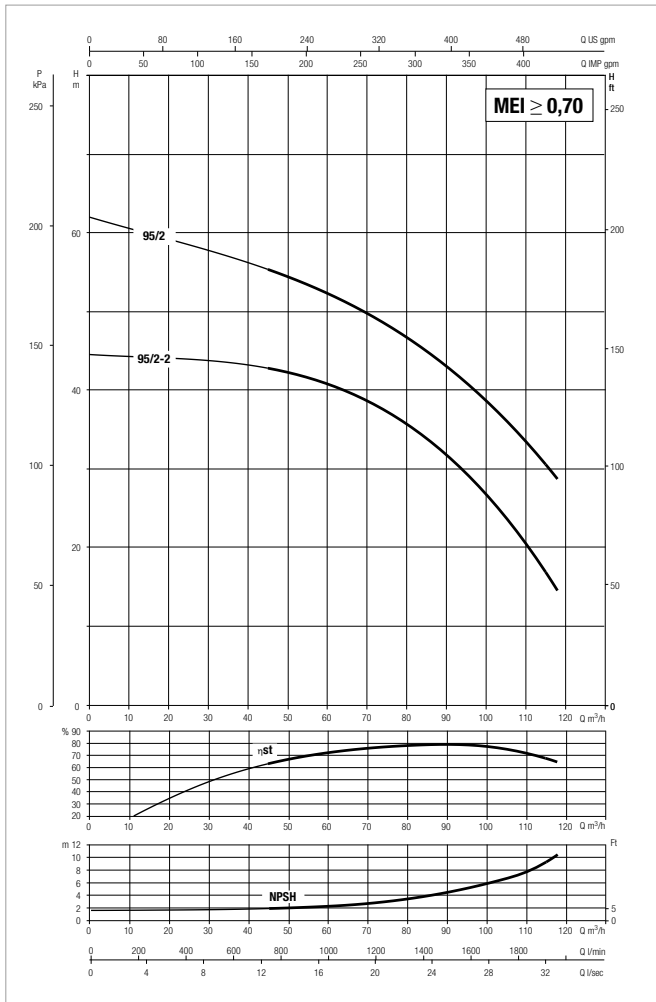

See hydraulic efficiency details on page 241.

The performance curves are based on kinematic viscosity values = 1 mm²/s and density equal to 1000 kg/m³. Curve tolerance according to ISO 9906.

MODEL	POWER INPUT 50 Hz	P2 NOMINAL		I _n A	r.p.m.
		kW	HP		
NKV 95/2-2 T	3 x 400 V ~	11	15	25,5	2930
NKV 95/2 T	3 x 400 V ~	15	20	34	2940

NKVE 95 - VERTICAL AXIS MULTISTAGE CENTRIFUGAL PUMPS WITH MCE/P INVERTER FOR PRESSURISATION SYSTEMS

Pumped liquid temperature range: from 15 °C to +80 °C - Maximum ambient temperature: +40 °C - Max flow rate: 118 m³/h

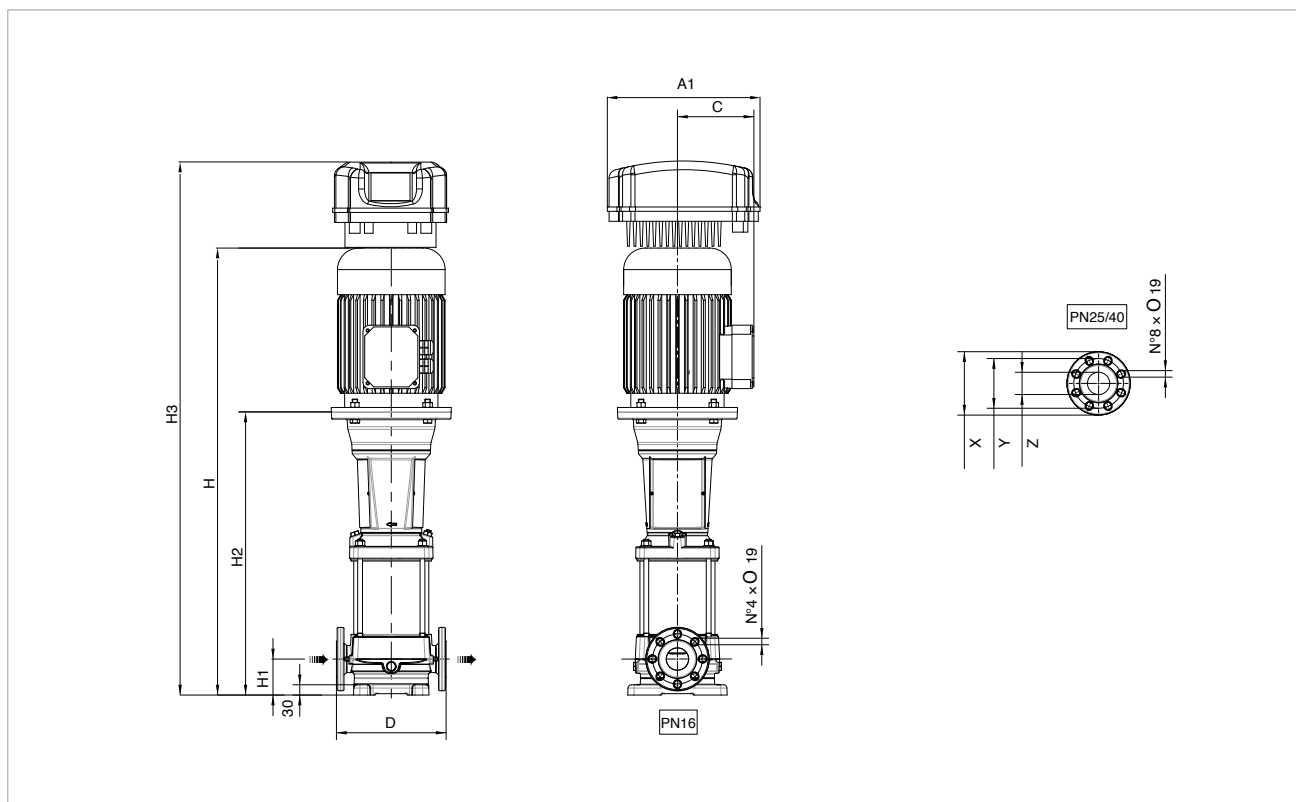

MODEL	N. OF STAGES	A1	C	D	H	H1	H2	H3	DNA = DNM (DN 100)			PACKING DIMENSIONS			VOL. m ³	WEIGHT kg
									X	Y	Z	L/A	L/B	H		
NKV 95/2-2 T	2	425	198	380	1354,2	140	849,2	1619,2	230	180	100	1820	500	630	0,58	221
NKV 95/2 T	3	425	198	380	1354,2	140	849,2	1619,2	230	180	100	1820	500	630	0,58	235

HYDRAULIC EFFICIENCY

EU 547/2012 REGULATION - MEI

GENERAL INFORMATION

The MEI index (Minimum Efficiency Index) was issued with the objective of defining a performance threshold value applicable to all the water pumps found on the market. The MEI index takes into account the size of the pump, its specific speed, and its speed of rotation.

The regulation applies to centrifugal pumps used for pumping clean waters included in the following categories:

- Axial suction pumps with support (ESOB)
- Horizontal monobloc axial suction pumps (ESCC)
- In-line monobloc axial suction pumps (ESCCI)
- Multistage vertical pumps (MS-V)
- Multistage submerged pumps (MSS)

MEI is a dimensionless indicator for hydraulic performance, and a measure of the quality of the sizing of the pump in relation to the performance.

The higher the MEI value, the better is the sizing of the pump in relation to the performance, and the lower is the annual energy consumption due to the use of the pump. In theory, the upper limit of the MEI values is open, and only depends on physical and technological limitations.

The minimum efficiency index (MEI) is based on the maximum diameter of the impeller. Multistage vertical water pumps must be tested in the 3-stage version.

The value of reference for the more efficient water pumps is $MEI \geq 0,70$.

The efficiency of a pump with turned impeller is generally lower to that of a pump with full impeller diameter. The turning of the impeller adapts the pump to a fixed point of operation, resulting in lower energy consumption.

The operation of this water pump with variable operating points can be more efficient and economical if controlled, for example, by means of a variable speed motor adapting the operation of the pump to the system.

The information on the efficiency of reference can be found at the address: www.dabpumps.com. In alternative contact your local sales representatives.

The $MEI=0,7$ and $MEI=0,4$ efficiency charts for the different types of pumps can be found at the website: www.europump.org/efficiencycharts

PUMP MODEL	IMPELLER	MEI
KE 55/200 T	Full	$\geq 0,70$
KE 36/200 T	Turned	
KE 40/200 T	Turned	
KE 50/400 T	Full	$\geq 0,50$
KE 40/400 T	Turned	
KE 50/800 T	Full	$\geq 0,60$
KE 30/800 T	Turned	
KE 40/800 T	Turned	
KE 35/1200 T	Full	$\geq 0,60$
KE 25/1200 T	Turned	

HYDRAULIC EFFICIENCY

EU 547/2012 REGULATION - MEI

PUMP MODEL	IMPELLER	MEI
NKM-GE 32-125.1/140 T 0,25	Full	≥ 0,40
NKP-GE 32-125.1/140 T 2,2	Full	≥ 0,40
NKP-GE 32-125.1/115 T 1,1	Turned	
NKP-GE 32-125.1/125 T 1,5	Turned	
NKM-GE 32-160.1/169 T 0,37	Full	
NKP-GE 32-160.1/177	Full	≥ 0,40
NKP-GE 32-160.1/155 T 2,2	Turned	
NKP-GE 32-160.1/166 T 3	Turned	
NKM-GE 32-200.1/200 T 0,55	Full	≥ 0,40
NKP-GE 32-200.1/205 T 5,5	Full	≥ 0,40
NKP-GE 32-200.1/188 T 4	Turned	
NKM-GE 32-125/142 T 0,37	Full	≥ 0,40
NKP-GE 32-125/142 T 3	Full	≥ 0,40
NKP-GE 32-125/110 T 1,1	Turned	
NKP-GE 32-125/120 T 1,5	Turned	
NKP-GE 32-125/130 T 2,2	Turned	
NKM-GE 32-160/169 T 0,55	Full	≥ 0,40
NKP-GE 32-160/177 T 5,5	Full	≥ 0,40
NKP-GE 32-160/151 T 3	Turned	
NKP-GE 32-160/163 T 4	Turned	
NKM-GE 32-200/219 T 1,1	Full	≥ 0,60
NKP-GE 32-200/210 T 7,5	Full	≥ 0,50
NKP-GE 32-200/190 T 5,5	Turned	
NKM-GE 40-125/142 T 0,55	Full	≥ 0,40
NKP-GE 40-125/139 1 A T 4	Full	≥ 0,40
NKP-GE 40-125/107 7 A T 1.5	Turned	
NKP-GE 40-125/120 5 A T 2.2	Turned	
NKP-GE 40-125/130 3 A T 3	Turned	
NKM-GE 40-160/166 T 0,75	Full	≥ 0,40
NKP-GE 40-160/172 T 7,5	Full	≥ 0,50
NKP-GE 40-160/158 T 5,5	Turned	
NKM-GE 40-200/219 T 1,5	Full	≥ 0,60
NKP-GE 40-200/210 T 11	Full	≥ 0,40
NKM-GE 40-250/260 T 3	Full	≥ 0,60
NKM-GE 40-250/245 T 2,2	Turned	
NKP-GE 40-250/230 T 15	Turned	≥ 0,50
NKM-GE 50-125/141 T 0,75	Full	≥ 0,40

PUMP MODEL	IMPELLER	MEI
NKP-GE 50-125/144 T 7,5	Full	≥ 0,40
NKP-GE 50-125/115 T 3	Turned	
NKP-GE 50-125/125 T 4	Turned	
NKP-GE 50-125/135 T 5,5	Turned	
NKM-GE 50-160/177 T 1,5	Full	≥ 0,60
NKP-GE 50-160/169 T 11	Full	≥ 0,40
NKP-GE 50-160/153 T 7,5	Turned	
NKM-GE 50-200/219 T 3	Full	≥ 0,60
NKP-GE 50-200/200 T 15	Turned	≥ 0,50
NKM-GE 50-250/263 T 4	Full	≥ 0,60
NKM-GE 65-125/144 T 1,1	Full	≥ 0,40
NKP-GE 65-125/137 T 7,5	Full	≥ 0,40
NKP-GE 65-125/127 T 5,5	Turned	
NKM-GE 65-160/177 T 2,2	Full	≥ 0,60
NKM-GE 65-160/153 T 1,1	Turned	
NKP-GE 65-160/173 T 15	Full	≥ 0,50
NKP-GE 65-160/157 T 11	Turned	
NKM-GE 65-200/210 T 3	Turned	≥ 0,60
NKP-GE 65-200/219 T 30	Full	≥ 0,70
NKM-GE 65-250/263 T 5,5	Full	≥ 0,50
NKM-GE 65-315/309 T 11	Full	≥ 0,40
NKM-GE 65-315/279 T 7,5	Turned	
NKM-GE 80-160/177 T 3	Full	≥ 0,40
NKM-GE 80-160/163 T 2,2	Turned	
NKP-GE 80-160/147-127 T 11	Turned	≥ 0,40
NKP-GE 80-160/153 T 15	Turned	≥ 0,40
NKM-GE 80-200/222 T 5,5	Full	≥ 0,40
NKM-GE 80-250/270 T 11	Full	≥ 0,40
NKM-GE 80-250/240 T 7,5	Turned	
NKM-GE 80-315/305 T 15	Turned	≥ 0,50
NKM-GE 100-200/214 T 7,5	Full	≥ 0,40
NKM-GE 100-200/200 T 5,5	Turned	
NKM-GE 100-250/270 T 15	Full	≥ 0,40
NKM-GE 100-250/250 T 11	Turned	
NKM-GE 125-250/243 T 15	Turned	≥ 0,40
NKM-GE 150-200/218 T 11	-	not applicable

HYDRAULIC EFFICIENCY

HYDRAULIC EFFICIENCY

EU 547/2012 REGULATION - MEI

PUMP MODEL	IMPELLER	MEI
KDNE 32-125.1/140 4P	Full	≥ 0,40
KDNE 32-125.1/140 2P	Full	≥ 0,40
KDNE 32-125.1/110 2P	Turned	
KDNE 32-125.1/130 2P	Turned	
KDNE 32-160.1/177 4P	Full	≥ 0,40
KDNE 32-160.1/177 2P	Full	≥ 0,40
KDNE 32-160.1/137 2P	Turned	
KDNE 32-160.1/145 2P	Turned	
KDNE 32-160.1/153 2P	Turned	
KDNE 32-200.1/207 4P	Full	≥ 0,50
KDNE 32-200.1/207 2P	Full	≥ 0,40
KDNE 32-200.1/170 2P	Turned	
KDNE 32-200.1/190 2P	Turned	
KDNE 32-125/142 4P	Full	≥ 0,50
KDNE 32-125/142 2P	Full	≥ 0,40
KDNE 32-125/125 2P	Turned	
KDNE 32-125/130 2P	Turned	
KDNE 32-160/177 4P	Full	≥ 0,40
KDNE 32-160/177 2P	Full	≥ 0,40
KDNE 32-160/145 2P	Turned	
KDNE 32-160/161 2P	Turned	
KDNE 32-200/219 4P	Full	≥ 0,60
KDNE 32-200/200 4P	Turned	
KDNE 32-200/219 2P	Full	≥ 0,60
KDNE 32-200/180 2P	Turned	
KDNE 32-200/200 2P	Turned	
KDNE 32-200/210 2P	Turned	
KDNE 40-125/142 4P	Full	≥ 0,40
KDNE 40-125/142 2P	Full	≥ 0,40
KDNE 40-125/120 2P	Turned	
KDNE 40-160/177 4P	Full	≥ 0,40
KDNE 40-160/161 4P	Turned	≥ 0,50
KDNE 40-160/177 2P	Full	
KDNE 40-160/145 2P	Turned	
KDNE 40-160/161 2P	Turned	≥ 0,60
KDNE 40-200/219 4P	Full	
KDNE 40-200/180 4P	Turned	
KDNE 40-200/200 4P	Turned	
KDNE 40-200/219 2P	Full	≥ 0,50
KDNE 40-200/180 2P	Turned	
KDNE 40-200/200 2P	Turned	

PUMP MODEL	IMPELLER	MEI
KDNE 40-250/260 4P	Full	≥ 0,40
KDNE 40-250/230 4P	Turned	
KDNE 40-250/240 4P	Turned	
KDNE 40-250/250 4P	Turned	
KDNE 40-250/220 2P	Turned	≥ 0,40
KDNE 50-125/144 4P	Full	≥ 0,40
KDNE 50-125/139 4P	Turned	
KDNE 50-125/144 2P	Full	≥ 0,40
KDNE 50-125/125 2P	Turned	
KDNE 50-125/139 2P	Turned	
KDNE 50-160/177 4P	Full	≥ 0,60
KDNE 50-160/137 4P	Turned	
KDNE 50-160/153 4P	Turned	
KDNE 50-160/169 4P	Turned	
KDNE 50-160/177 2P	Full	≥ 0,50
KDNE 50-160/145 2P	Turned	
KDNE 50-160/161 2P	Turned	
KDNE 50-200/219 4P	Full	≥ 0,60
KDNE 50-200/170 4P	Turned	
KDNE 50-200/190 4P	Turned	
KDNE 50-200/210 4P	Turned	
KDNE 50-200/180 2P	Turned	≥ 0,40
KDNE 50-200/190 2P	Turned	
KDNE 50-250/263 4P	Full	≥ 0,60
KDNE 50-250/220 4P	Turned	
KDNE 65-125/144 4P	Full	≥ 0,40
KDNE 65-125/130 4P	Turned	
KDNE 65-125/144 2P	Full	≥ 0,40
KDNE 65-125/120 2P	Turned	
KDNE 65-125/130 2P	Turned	
KDNE 65-160/177 4P	Full	≥ 0,60
KDNE 65-160/137 4P	Turned	
KDNE 65-160/153 4P	Turned	
KDNE 65-160/169 4P	Turned	

HYDRAULIC EFFICIENCY

EU 547/2012 REGULATION - MEI

PUMP MODEL	IMPELLER	MEI
KDNE 65-160/137 2P	Turned	≥ 0,50
KDNE 65-160/153 2P	Turned	
KDNE 65-160/169 2P	Turned	
KDNE 65-200/219 4P	Full	≥ 0,60
KDNE 65-200/180 4P	Turned	
KDNE 65-200/190 4P	Turned	
KDNE 65-200/170 2P	Turned	≥ 0,60
KDNE 65-250/263 4P	Full	≥ 0,50
KDNE 65-250/240 4P	Turned	
KDNE 65-315/320 4P	Full	≥ 0,50
KDNE 65-315/260 4P	Turned	
KDNE 65-315/290 4P	Turned	
KDNE 80-160/177 4P	Full	≥ 0,50
KDNE 80-160/153 4P	Turned	
KDNE 80-160/161 4P	Turned	
KDNE 80-160/153-136 2P	Turned	≥ 0,40
KDNE 80-200/222 4P	Full	≥ 0,50
KDNE 80-200/170 4P	Turned	
KDNE 80-200/200 4P	Turned	
KDNE 80-250/270 4P	Full	≥ 0,40
KDNE 80-250/230 4P	Turned	
KDNE 80-250/260 4P	Turned	
KDNE 80-315/290 4P	Turned	≥ 0,40
KDNE 100-200/219 4P	Full	≥ 0,40
KDNE 100-200/180 4P	Turned	
KDNE 100-200/200 4P	Turned	
KDNE 100-250/240 4P	Turned	≥ 0,40
KDNE 100-250/260 4P	Turned	
KDNE 100-315/275 4P	Turned	≥ 0,40
KDNE 125-250/230 4P	Turned	≥ 0,40
KDNE 150-200/218-182 4P	Turned	not applicable
KDNE 150-200/224 4P	Turned	

HYDRAULIC EFFICIENCY

EU 547/2012 REGULATION - MEI

PUMP MODEL	NUMBER OF STAGES	MEI	η_{PL}	η_{BEP}	η_{OL}
KVCE 35/30 M	4	$\geq 0,40$	35,95	38,50	37,99
KVCE 45/30 M	5		34,29	36,35	36,08
KVCE 50/30 M	6		29,03	30,86	30,56
KVCE 60/30 M	7		28,82	30,95	30,56
KVCE 70/30 M	8		35,16	37,89	37,32
KVCE 30/50 M	3	$\geq 0,60$	40,75	43,10	42,76
KVCE 40/50 M	4		40,73	43,34	42,91
KVCE 55/50 M	5		38,90	41,70	41,20
KVCE 65/50 M	6		37,53	39,21	38,75
KVCE 75/50 M	7		36,39	38,91	38,35
KVCE 30/80 M	4	$\geq 0,40$	44,06	46,30	45,84
KVCE 40/80 M	5		43,43	46,97	46,80
KVCE 45/80 M	6		41,91	43,96	43,57
KVCE 55/80 M	7		41,05	43,00	42,63
KVCE 35/120 M	3	$\geq 0,50$	49,31	51,00	50,76
KVCE 45/120 M	4		47,59	49,50	48,96
KVCE 60/120 T	5		47,81	49,44	48,97
KVCE 70/120 T	6		47,58	49,00	48,61
KVCE 85/120 T	7		49,23	50,84	50,20

PUMP MODEL	NUMBER OF STAGES	MEI	η_{PL}	η_{BEP}	η_{OL}
KVE 3/10 M	10	$\geq 0,40$	47,83	52,40	51,69
KVE 3/12 M	12		49,22	53,67	52,94
KVE 3/15 M	15		46,57	50,40	49,75
KVE 3/18 T	18		48,11	41,91	51,17
KVE 6/7 M	7	$\geq 0,40$	50,28	54,00	53,47
KVE 6/9 M	9		50,52	55,10	54,34
KVE 6/11 M	11		49,10	52,67	52,16
KVE 6/15 T	15		51,09	55,20	54,44
KVE 10/4 M	4	$\geq 0,40$	53,89	55,88	55,60
KVE 10/5 M	5		54,72	57,27	56,81
KVE 10/6 M	6		57,77	60,20	59,48
KVE 10/8 T	8		57,41	60,77	60,59

HYDRAULIC EFFICIENCY

EU 547/2012 REGULATION - MEI

PUMP MODEL	NUMBER OF STAGES	MEI	η PL	η BEP	η OL
NKVE 10/3	3	$\geq 0,60$	63,39	66,41	65,77
NKVE 10/2	2		64,88	67,70	67,39
NKVE 10/4	4		63,30	65,89	65,29
NKVE 10/5	5		65,48	69,58	68,81
NKVE 10/6	6		66,55	68,40	67,76
NKVE 10/7	7		66,11	68,52	67,86
NKVE 10/8	8		64,66	67,13	66,08
NKVE 10/9	9		66,77	68,94	68,26
NKVE 10/10	10		66,44	69,13	68,43
NKVE 10/12	12		65,97	68,88	67,71
NKVE 10/14	14		63,80	66,29	65,51
NKVE 10/16	16		62,88	65,32	64,69
NKVE 10/18	18		64,39	66,91	66,19
NKVE 10/20	20		64,45	66,82	66,19
NKVE 10/22	22	65,23	67,61	66,72	

PUMP MODEL	NUMBER OF STAGES	MEI	η PL	η BEP	η OL
NKVE 15/3	3	$\geq 0,60$	68,74	72,03	71,26
NKVE 15/2	2		67,43	71,35	70,68
NKVE 15/4	4		70,15	72,54	71,91
NKVE 15/5	5		70,40	74,23	73,48
NKVE 15/6	6		70,19	73,29	72,46
NKVE 15/7	7		69,81	73,65	72,91
NKVE 15/8	8		68,06	71,49	70,86
NKVE 15/9	9		69,77	73,07	72,30
NKVE 15/10	10		66,95	70,35	69,67
NKVE 15/12	12		70,09	74,28	73,55
NKVE 15/14	14		69,44	72,75	72,00
NKVE 15/16	16		70,90	74,76	74,01
NKVE 15/17	17		70,55	74,26	73,35

HYDRAULIC EFFICIENCY

EU 547/2012 REGULATION - MEI

PUMP MODEL	NUMBER OF STAGES	MEI	η PL	η BEP	η OL
NKVE 20/3	3	$\geq 0,60$	70,47	71,40	70,59
NKVE 20/2	2		67,45	73,36	72,50
NKVE 20/4	4		66,24	69,74	69,33
NKVE 20/5	5		72,31	74,50	73,90
NKVE 20/6	6		70,37	73,40	72,90
NKVE 20/7	7		70,13	74,04	73,38
NKVE 20/8	8		69,63	72,06	71,60
NKVE 20/9	9		71,68	74,41	73,68
NKVE 20/10	10		70,44	73,42	72,96
NKVE 20/12	12		71,47	74,11	73,45
NKVE 20/14	14		71,33	75,51	74,86

PUMP MODEL	NUMBER OF STAGES	MEI	η PL	η BEP	η OL
NKVE 32/3	3	$\geq 0,70$	70,08	74,12	73,16
NKVE 32/2	2		70,08	74,12	73,16
NKVE 32/3-2	3		67,38	71,10	70,20
NKVE 32/4	4		70,08	74,12	73,16
NKVE 32/5-2	5		68,40	72,20	71,44
NKVE 32/5	5		70,08	74,12	73,16
NKVE 32/6	6		70,08	74,12	73,16
NKVE 32/7-2	7		68,82	72,70	72,04

PUMP MODEL	NUMBER OF STAGES	MEI	η PL	η BEP	η OL
NKVE 45/3	3	$\geq 0,70$	73,47	76,37	75,25
NKVE 45/2-2	2		69,13	71,65	70,46
NKVE 45/2	2		73,47	76,37	75,25
NKVE 45/4	4		73,47	76,37	75,25

PUMP MODEL	NUMBER OF STAGES	MEI	η PL	η BEP	η OL
NKVE 65/2-2	2	$\geq 0,70$	70,92	77,97	77,08
NKVE 65/2	2		73,71	78,96	77,11
NKVE 65/3-2	3		72,27	77,22	76,17

PUMP MODEL	NUMBER OF STAGES	MEI	η PL	η BEP	η OL
NKVE 95/2-2	2	$\geq 0,70$	72,37	78,87	77,79
NKVE 95/2	2		74,38	79,43	77,94

ACCESSORIES

ACCESSORIES

CENTRIFUGAL ELECTRONIC PUMPS

COUNTER-FLANGE KIT	MODEL	COUNTER-FLANGES AND GASKETS	THREADED	MATERIAL	PN	NKM-GE - NKP-GE	KDNE
 <p>DN 32</p>	DN 32	1 x DN 32 + 1 x DN 50	Threaded	STEEL	16	•	•
	DN 40	1 x DN 40 + 1 x DN 65	Threaded	STEEL	16	•	•
	DN 50	1 x DN 50 + 1 x DN 65	Threaded	STEEL	16	•	•
	DN 65	1 x DN 65 + 1 x DN 80	Threaded	STEEL	16	•	•
	DN 32	1 x DN 32 + 1 x DN 50	To be welded	STEEL	16	•	•
	DN 40	1 x DN 40 + 1 x DN 65	To be welded	STEEL	16	•	•
	DN 50	1 x DN 50 + 1 x DN 65	To be welded	STEEL	16	•	•
	DN 50/1	1 x DN 50 + 1 x DN 80	To be welded	STEEL	16		•
	DN 65	1 x DN 65 + 1 x DN 80	To be welded	STEEL	16	•	•
	DN 65/1	1 x DN 65 + 1 x DN 100	To be welded	STEEL	16		•
	DN 80	1 x DN 80 + 1 x DN 100	To be welded	STEEL	16	•	•
	DN 80/1	1 x DN 80 + 1 x DN 125	To be welded	STEEL	16		•
	DN 100	1 x DN 100 + 1 x DN 125	To be welded	STEEL	16	•	•
	DN 125	1 x DN 125 + 1 x DN 150	To be welded	STEEL	16	•	•
	DN 150	1 x DN 150 + 1 x DN 200	To be welded	STEEL	16 (10 x DN 200)	•	•
	DN 200	1 x DN 200 + 1 x DN 250	To be welded	STEEL	16 (10 x DN 200)		•
	DN 250/1	1 x DN 250 + 1 x DN 300	To be welded	STEEL	16		•
DN 300	1 x DN 300 + 1 x DN 350	To be welded	STEEL	16		•	
DN 350	1 x DN 350 + 1 x DN 400	To be welded	STEEL	16		•	

The kit includes the suction and delivery counter-flanges with gaskets, screws and bolts required for the size of the relevant pump.

ACCESSORIES - VERTICAL CENTRIFUGAL ELECTRONIC PUMPS

COUNTER-FLANGE KIT	MODEL	COUNTER-FLANGES AND GASKETS	THREADED	MATERIAL	PN	NKVE 10-15-20	NKVE 32 - 45	NKVE 65- 95
 <p>DN 40</p>	DN 40	2 x DN 40	Threaded	STEEL	40	•		
	DN 50	2 x DN 50	Threaded	STEEL	40	•		
	DN 65	2 x DN 65	Threaded	STEEL	40		•	
	DN 80	2 x DN 80	Threaded	STEEL	40		•	•
	DN 100	2 x DN 100	Threaded	STEEL	25			•

PORTS	MODEL	KVCE
	MT 1" ¼ PORTS	•

Ports must be ordered separately, one for the suction, and one for the delivery

ACCESSORIES

CENTRIFUGAL ELECTRONIC PUMPS

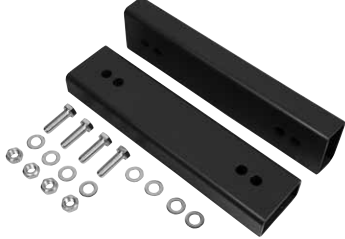
SPACER KIT	MODEL	FOR PUMP TYPE	P2 kW	DIMENSIONS A x B x H mm	NKM-GE 4 POLI	NKP-GE 2 POLI
 <p>KIT SPESSORI nr 5</p>	KIT SPESSORI nr 1	NKM-GE 65-315/309/11/4	11	90 x 335 x 65	•	
	KIT SPESSORI nr 5	NKM-GE 80-250/270/11/4	11	80 x 290 x 40	•	
	KIT SPESSORI nr 2	NKM-GE 80-315/305/15/4	15	90 x 335 x 90	•	
	KIT SPESSORI nr 3	NKM-GE 80-315/320/18.5/4	18,5	100 x 320 x 70	•	
		NKM-GE 80-315/334/22/4	22			
	KIT SPESSORI nr 1	NKM-GE 100-250/250/11/4	11	90 x 335 x 65	•	
		NKM-GE 100-250/270/15/4	15			
	KIT SPESSORI nr 3	NKM-GE 100-315/300/18.5/4	18,5	100 x 320 x 70	•	
		NKM-GE 100-315/316/22/4	22			
	KIT SPESSORI nr 2	NKM-GE 125-250/243/15/4	15	90 x 335 x 90	•	
	KIT SPESSORI nr 3	NKM-GE 125-250/256/18.5/4	18,5	100 x 320 x 70	•	
		NKM-GE 125-250/266/22/4	22			
	KIT SPESSORI nr 4	NKM-GE 150-200/218/11/4	11	80 x 290 x 120	•	
	KIT SPESSORI nr 6	NKP-GE 32-125/142/3/2	3	50 x 100 x 20		•
		NKP-GE 32-160/177/5.5/2	5,5			
		NKP-GE 40-125/130/3/2	3			
		NKP-GE 40-125/139/4/2	4			
		NKP-GE 40-160/158/5.5/2	5,5			
		NKP-GE 40-160/172/7.5/2	7,5			
	KIT SPESSORI nr 7	NKP-GE 40-200/210/11/2	11	70 x 332 x 20		•
		NKP-GE 40-250/230/15/2	15			
		NKP-GE 40-250/245/18.5/2	18,5			
	KIT SPESSORI nr 6	NKP-GE 50-125/135/5.5/2	5,5	50 x 100 x 20		•
		NKP-GE 50-125/144/7.5/2	7,5			
	KIT SPESSORI nr 7	NKP-GE 50-160/169/11/2	11	70 x 332 x 20		•
		NKP-GE 50-200/200/15/2	15			
		NKP-GE 50-200/210/18.5/2	18,5			
		NKP-GE 65-160/157/11/2	11			
NKP-GE 65-160/173/15/2		15				
NKP-GE 65-200/190/18.5/2		18,5				
NKP-GE 80-160/147-127/11/2		11				
NKP-GE 80-160/153/15/2		15				
NKP-GE 80-160/163/18.5/2		18,5				
KIT SPESSORI nr 8	NKP-GE 80-200/190/30/2	30	70 x 125 x 20		•	

Available on request, separately from the pump. Used to place the pump in the horizontal position during installation, to compensate for the different pump / motor axis heights.

The kits include two spacers with sizes A (width), B (length), and H (height) as shown in the table.

Spacers with H size exceeding 20 mm are supplied with screws, nuts, and washers to secure the pump/motor to the spacer.

TECHNICAL APPENDIX

GENERAL INFORMATION

FUNDAMENTAL TERMS USED IN PUMPS

The following is a list of fundamental terms used in pumps and an explanation of their meanings. Their knowledge is necessary in order to discuss hydraulic pumps. All measurements are given in Technical units. Reference should be made to the chart for their international and Anglo-Saxon equivalents.

HEAD

Head means height, difference in level, gradient. For example if a pump has a flow of Q litres per second and a head of 30 metres, it means that it is capable of raising Q litres of liquid by 30 metres every second (therefore achieving a 30 metre gradient). For each given pump, the head is determined by its construction, such as the external diameter of the impeller and the speed of rotation, but it is not affected by the pumped liquid. This means that the pump as such can raise by 30 metres Q litres per second of water, petrol, mercury, etc.; the only difference in the three cases will be the power of the motor required.

SPECIFIC WEIGHT OF A LIQUID OR FLUID

The specific weight of a liquid or fluid is the weight per unit volume of the liquid/fluid. Specific weight is usually measured in kg/dm³ or kg/l, remembering that 1 dm³ equals 1 litre.

PRESSURE

Pressure means weight per unit of area (e.g. kg/cm²), and it should not be confused with head. In the case of liquids, the pressure that the liquid exerts on a surface is given by the product of the head (or height) of the liquid, multiplied by its specific weight. For this reason, the column of several km of air on the earth's surface produces at sea level a pressure of about 1kg/cm² (equal to approx. 1 atmosphere). If the same column were of water rather than air, the pressure would be some 700 to 800 times greater, due to the fact that water has a specific weight approximately 700-800 times greater than that of air.

Bearing in mind that a column of water 10 m high is equivalent to approx. 1 kg/cm², if we placed a manometer on the delivery of the pump, the following pressure increases would be measured:

- a) with petrol (specific weight 0,7 kg/dm³) = $0,7 \times 0,001 \times 30 \times 100 = 2,1 \text{ kg/cm}^2$
- b) with water (specific weight 1,0 kg/dm³) = $0,1 \times 0,001 \times 30 \times 100 = 3,0 \text{ kg/cm}^2$
- c) with mercury (specific weight 13,6 kg/dm³) = $13,6 \times 0,001 \times 30 \times 100 = 40,8 \text{ kg/cm}^2$

FLOW

Flow means the quantity of liquid or fluid that passes through a point, such as the delivery outlet of a pump, or a cross section of a pipe, in the set unit of time.

This can be measured in litres per minute (l/min), litres per second (l/s), cubic metres per hour (m³/h) etc.

It should be noted that there is a perfect analogy between the flow of water through a pipe and the flow of electricity through a wire. It is sufficient to remember that hydraulic head is equivalent to electrical potential or voltage, and hydraulic flow is equivalent to electric current or amperes in electrotechnics. Even their behaviour is the same. Just as a thin wire restricts the flow of electricity more than one with a larger section, in the same way, a pipe of a smaller diameter offers a greater resistance to the flow of a liquid than one of a larger one. Just as the passage of electric current through the wire to a cable needs a voltage difference, in the same way, the flow of a liquid or fluid through a pipe needs a certain head.

There will never be a movement of liquid between two points of a perfectly horizontal pipe, and with the liquid at the same head in both points. This is due to the fact that, in the same way as the cable exerts a certain resistance to the passage of the electric current (electric resistance), the pipe also exerts a certain resistance to the passage of the fluid, the extent of which depends on the quality of the pipe (material, shape, presence of scale) and its section, and therefore the speed at which the fluid runs through the pipe. This resistance is called head loss.

HEAD LOSS

Head loss is that part of the head, possessed by the liquid, which is lost when passing through a pipe, a valve, a filter, etc. This loss cannot be recovered, as it is lost due to friction. Going back to the analogy between electrical and hydraulic phenomena, just as the losses in a cable increase in proportion with the current, so head losses are proportionally greater as the speed of the liquid increases. This means that the more the flow is restricted by scaled pipes, clogged filters, partially closed valves etc. the greater the head loss will be.

PUMP

A pump is a machine used to give a certain head to a liquid that passes through it. The head can be used to raise the liquid to a higher level, or to make it flow inside a pipe, or even in the open air, so that it covers a certain distance. The characteristics of a pump are:

- a) **Flow** (the quantity of liquid that is moved through the pump in a unit of time)
- b) **Head** (that is the height at which the pump is capable lifting the flow)

Based on the existing relationship between the flow and the head, it is possible to have:

- a) Pumps with small flow and large head (piston pumps, rotary pumps, small centrifugal pumps).
- b) Pumps with medium flow and medium head (centrifugal pumps in general).
- c) Pumps with large flow and small head (helico-centrifugal pumps, propeller pumps).

TECHNICAL APPENDIX

CENTRIFUGAL ELECTRONIC PUMPS

Centrifugal pumps, helico-centrifugal pumps and propeller pumps have a rotary motion and their speed is universally measured in revolutions per minute (rpm). With these machines operating at a given speed, for each given value of flow, there is only one value of head. This means that in order to increase or decrease the performance of these types of pumps, the operating speed must be varied accordingly. Basically, the liquid passing through the pump is supplied with energy that is related to the head and the speed of the liquid itself. This energy supplied within the unit of time is known as delivered power.

DELIVERED POWER

The delivered power is the power delivered by the pump to the liquid. The value of this delivered power depends on three factors: flow, head, and specific weight of the pumped liquid. The higher these three factors, the higher is the power delivered by the pump. For example, a pump delivering petrol does less work than when delivering sulphuric acid, because the specific weights of the two liquids are different.

In order to pump a liquid, a pump must be driven by a motor. In the vast majority of cases, this is either an electric, or an internal combustion motor. Electric motors use electric power, while internal combustion motors (engines) use oil or oil derivative fuels. The power that the pump needs in order to operate is called absorbed power.

DELIVERED POWER CALCULATION

Delivered power is normally expressed in kW or HP, indicating with:

Q = the flow

H = the head in metres of the column of liquid (m.c.l.)

γ = the specific weight of the liquid

The delivered power (P3) is calculated using one of the following equations:

$$P_3 = \frac{\gamma \text{ (kg/dm}^3\text{)} \times Q \text{ (l/s)} \times H \text{ (m.c.l.)}}{75} \text{ in HP}$$

$$P_3 = \frac{\gamma \text{ (kg/dm}^3\text{)} \times Q \text{ (m}^3\text{/h)} \times H \text{ (m.c.l.)}}{270} \text{ in HP}$$

$$P_3 = \frac{\gamma \text{ (kg/dm}^3\text{)} \times Q \text{ (l/s)} \times H \text{ (m.c.l.)}}{102} \text{ in kW}$$

$$P_3 = \frac{\gamma \text{ (kg/dm}^3\text{)} \times Q \text{ (l/min)} \times H \text{ (m.c.l.)}}{4500} \text{ in HP}$$

$$P_3 = \frac{\gamma \text{ (kg/dm}^3\text{)} \times Q \text{ (m}^3\text{/h)} \times H \text{ (m.c.l.)}}{367} \text{ in kW}$$

$$P_3 = \frac{\gamma \text{ (kg/dm}^3\text{)} \times Q \text{ (l/min)} \times H \text{ (m.c.l.)}}{6120} \text{ in kW}$$

ABSORBED POWER

Absorbed power is the power that the pump absorbs from the motor, to give to the liquid the delivered power discussed above.

Not all the absorbed power becomes delivered power, as some power is lost through friction, and even more within the pump itself, due to hydraulic losses. It is therefore clear that the delivered power is always less than the absorbed power, and the relation between the two is a number always lower than 1. This number is known as the efficiency.

YIELD

The efficiency is obtained by dividing the delivered power by the absorbed power, and is normally expressed as a percentage. For example, an efficiency of 75 % of a pump indicates that only 75 % of the absorbed power is converted into delivered power, with the remaining 25 % being lost due to friction. Therefore, the higher the efficiency of a pump, the smaller the portion of absorbed power being lost. If one then considers that the cost of energy relates to the absorbed power, it immediately becomes apparent just how important efficiency is. If we compare two pumps with the same 1 HP delivered power, but with an efficiency of 50 % for the first, and 60 % for the second, we can assume that the first one will need 2 HP to supply 1, while the second will only need 1,67 HP to achieve the same result. This means that the efficiency of a pump expresses, better than any other parameter, the quality of the pump and the related savings in terms of operating costs.

CALCULATION OF POWER OUTPUTS

P1: is the power absorbed by the motor in kW (generally indicated by the wattmeter).

P2: the power delivered by the motor in kW. This is measured at the brake (it basically is the power absorbed by the pump).

P3: the power delivered by the pump in kW.

$$\text{Power output of the motor } \eta = \frac{P_2}{P_1}$$

$$\text{Power output of the motor } \eta = \frac{P_3}{P_2}$$

$$\text{Power output of the motor } \eta = \frac{P_3}{P_1}$$

THE HEAD OF A PUMP AND ITS MEASUREMENT

The head of a pump is always the differential head, or that given by the pump itself. This is generally expressed in metres. In order to ascertain the head of a surface pump, during its operation it is necessary to measure the value of the head both at the suction and at the delivery of the pump itself, making sure that the readings are taken at the same level, which is called the reference plane. Two cases are possible, depending on installation:

1) the value of the head at the suction is negative (i.e. below zero shown on the manometer): in this case, the level of the liquid collected is lower than the level of the suction inlet.

2) the value of the head at the suction is positive (i.e. above zero shown on the manometer) in this case, the level of the liquid collected is higher than the level of the suction inlet (flooded suction).

In the first case the head of the pump is given by the sum of the two readings, while in the second it is given by subtracting the value of the head at the suction inlet from the value at the delivery outlet.

Finally, it is necessary to make sure that the readings at the suction and the delivery have been taken from apertures of the same diameter, so that they are not distorted by a difference in the speed of the liquid at the point of measurement. Any correction is made by calculating the dynamic head, or that part of the head linked with the speed of the liquid, which means that part of the head that the liquid possesses at the measuring section, due to the fact that it is moving. The dynamic head H_d , expressed in metres, is calculated using the following formula:

$$H_d = \frac{v^2}{2g}$$

where: v = speed of the fluid at the measuring point, given in m/s

g = acceleration of gravity (9,81), expressed in m/s²

$2g = 2 \times 9,81 = 19,62 \text{ m/s}^2$

The correction of the head is given by the difference between the dynamic head at the delivery, and the dynamic head at the suction. It is therefore clear that if the readings upstream and downstream the pump have been taken on pipes of the same diameter, and therefore with the liquid flowing at the same speed, the correction is zero.

In order to ascertain the head of a submerged impeller pump, it is sufficient, during operation, to measure the head at the delivery port. In this case, the head of the pump is given by adding the value read to the dynamic head (always at the delivery port), and to the difference of level between the free surface of the liquid collected and the manometer.

VARIATION IN PUMP HEAD IN RELATION TO SPEED VARIATION

The performance of a pump is directly connected to its speed in rpm (n). Providing that there is no cavitation, the law of similarity may be used, which is expressed as follows:

$$Q_x = Q \times \frac{n_x}{n}$$

$$H_x = H \times \left(\frac{n_x}{n}\right)^2$$

$$P_{2-x} = P_2 \times \left(\frac{n_x}{n}\right)^3$$

For example, when doubling the number of revolutions (n_x) one obtains:

Q_x = the value of the flow doubles

H_x = the value of the head is 4 times higher

P_{2-x} = the value of the absorbed power is 8 times higher

$Q - H - P_2$ are the values at speed n

$Q_x - H_x - P_{2-x}$ are the values at speed n_x .

PRACTICAL NOTES ON NPSH

NPSH stands for Net Positive Suction Head.

The physical meaning of this expression is the absolute pressure that must exist at the suction port of the pump in order to pump the liquid without causing cavitation.

This can occur when the absolute pressure falls to values likely to allow the formation of vapour bubbles within the fluid, causing the pump to work with reduced head.

Therefore, NPSH can also be seen as the pressure required to compensate load losses in the path between the suction port and the point with the lowest pressure of the impeller.

All this demonstrates the importance of checking that the pump is not producing cavitation, as in addition to creating high noise similar to metal hammering, cavitation will also quickly damage the impeller.

A special formula associates the NPSH value required by the pump with the conditions of the system and with the type of liquid, allowing to calculate the minimum pressure required at the suction, and consequently to determine the position in which to locate the pump in relation to the free surface of the liquid to be pumped.

The general NPSH formula is:

$$NPSH = Z1 + \left(\frac{p1+pb-pv}{\gamma} \times 10 \right) - Hr$$

$$Z1 = NPSH - \left(\frac{p1+pb-pv}{\gamma} \times 10 \right) + Hr$$

where:

Z1 = the difference in level (in m) between the axis of the pump and the free surface of the liquid to be pumped.

p1 = the possible pressure (in kg/cm²) on the surface of the liquid in the tank from which it is collected. If the liquid is collected from an open tank and the surface of the liquid is in contact with the atmosphere, p1 will be equal to 0.

pb = atmospheric pressure (in kg/cm²) at the site of installation.

pv = the vapour tension (in kg/cm²) of the liquid at pumping temperature.

γ = the specific weight (in kg/dm²) of the liquid at pumping temperature.

10 = conversion factor of the units of measure used.

Hr = head loss (in m) in the suction pipework.

To give a practical example, the diagram below is of a system (see the Figure) for a centrifugal pump, for which a flow rate Q of 235 l/min is required, under four different conditions.

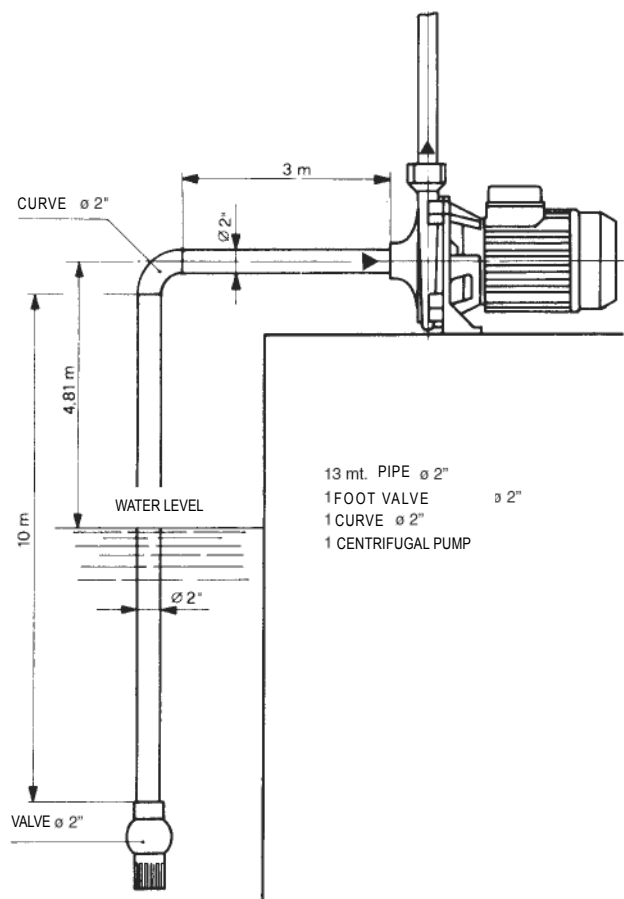

CALCULATION OF THE HEAD LOSS AT THE SUCTION (Hr)

Flow rate : $Q = 235 \text{ l/min} = 0,00392 \text{ m}^3/\text{s}$

Cross section area of the pipe : $S = 19,6 \text{ cm}^2 = 0,00196 \text{ m}^2$

Velocity of the water in the pipe : $V = Q/S = \frac{0,00392}{0,00196} = 2 \text{ m/s}$

The head losses (see table 1 & 2) are:

- 2" foot valve = 0,610 m

- Curve (assume $\frac{d}{R} = 1$) = 0,058 m

- Suction piping (10 m + 3 m) = 1,370 m

- Total loss at the suction = 2,040 m

Let's now consider the four different conditions, notwithstanding the Hr head losses, and assuming an NPSH for the pump equal to 3,25 m, at the flow rate being considered. The atmospheric pressure p_b can be read from the diagram, the vapour tension p_v and the specific weight can be found on table 3.

1st case: system at sea level and water at 20 °C.

$$3,25 = Z_1 + \left(\frac{1,033 - 0,0238}{0,9982} \times 10 \right) - 2,04$$

$$Z_1 = 3,25 - \left(\frac{1,033 - 0,0238}{0,9982} \times 10 \right) + 2,04 = - 4,82$$

Which means that the pump, for the flow rate being considered, can collect water at 20° from a maximum depth of 4,82 m. It must be noted that a for flow rate greater than 235 l/min, when increasing the value of the NPSH of the pump and the head loss at the suction, the maximum suction depth will be less 4,82m. The opposite happens for flow rates lower than 235 l/min. From this, it follows that in order to bring the pump back to regular operation, it is often sufficient to partially close the delivery valve and reduce the flow rate.

2nd case: system at sea level and water at 60 °C.

$$3,25 = Z_1 + \left(\frac{1,033 - 0,2031}{0,9831} \times 10 \right) - 2,04$$

$$Z_1 = 3,25 - \left(\frac{1,033 - 0,2031}{0,9831} \times 10 \right) + 2,04 = - 3,15$$

Which means that the pump, for the flow rate being considered, can collect water at 60° from a maximum depth of 3,15 m.

3rd case: system at sea level and water at 90 °C.

$$3,25 = Z_1 + \left(\frac{1,033 - 0,7149}{0,9653} \times 10 \right) - 2,04$$

$$Z_1 = 3,25 - \left(\frac{1,033 - 0,7149}{0,9653} \times 10 \right) + 2,04 = - 1,99$$

Which means that the free surface of the water at 90 °C for the flow rate considered must be 1,99 metres higher than the axis of the pump.

4th case: system at 1500 m above sea level and water at 50 °C.

$$3,25 = Z_1 + \left(\frac{0,860 - 0,1258}{0,9880} \times 10 \right) - 2,04$$

$$Z_1 = 3,25 - \left(\frac{0,860 - 0,1258}{0,9880} \times 10 \right) + 2,04 = - 2,14$$

Which means that the pump, for the flow rate being considered, in a system at 1500 metres above sea level can collect water at 50 °C from a maximum depth of 2,14 metres.

Note: it's always wise to include a safety margin (0,5m for cold water) to allow for errors and unforeseen variations in the estimated values. Such a margin is even more important with liquids near boiling point, as small temperature changes can produce large differences in operating conditions. For example, in case 3, if the temperature of the water were at any time to reach 95°C, instead of 90 °C, the necessary pump suction pressure would no longer be 1,99 metres, but would increase from 1,99 metres to 3,51 metres.

NOTES ON THE MOTORS OF ELECTRIC PUMPS

INDEX OF SYMBOLS USED	
P_1	: POWER ABSORBED BY THE MOTOR IN KW.
P_2	: POWER DELIVERED BY THE MOTOR IN KW OR HP.
$V \sim$	= AC POWER INPUT VOLTAGE AT THE MAINS.
Hz	= FREQUENCY IN CYCLES PER SECOND OF THE POWER INPUT VOLTAGE.
I	= CURRENT ABSORBED BY THE MOTOR IN AMPERES.
$\cos\varphi$	= POWER FACTOR.
$n^{1/min}$	= SPEED OF ROTATION IN RPM.
η	= OUTPUT POWER (RELATION BETWEEN DEVELOPED POWER AND ABSORBED POWER P_2/P_1).
p	= NUMBER OF POLES OF THE MOTOR.
Cn	= NOMINAL TORQUE OF THE MOTOR.

NO-LOAD SPEED OF ROTATION

The no-load speed of single-phase and three-phase electric induction motors is given by the formula:

$$n^{1/min} = \frac{120 \times \text{Hz}}{p}$$

No-load speed of rotation $n^{1/min}$

FREQUENCY Hz	2 POLES	4 POLES
50	3000	1500
60	3600	1800

The full-load speed is 2 to 7 % lower than the no-load speed (2 to 7 % sliding).

CURRENT ABSORBED

Single-phase: $I = \frac{1000 \times P_2 \text{ (kW)}}{V \times \cos\varphi \times \eta}$ or: $I = \frac{736 \times P_2 \text{ (HP)}}{V \times \cos\varphi \times \eta}$

Three-phase: $I = \frac{1000 \times P_2 \text{ (kW)}}{1.73 \times V \times \cos\varphi \times \eta}$ or: $I = \frac{736 \times P_2 \text{ (HP)}}{1.73 \times V \times \cos\varphi \times \eta}$

ABSORBED POWER

Single-phase: $P_1 \text{ (kW)} = \frac{V \times I \times \cos\varphi}{1000}$

Three-phase: $P_1 \text{ (kW)} = \frac{1.73 \times V \times I \times \cos\varphi}{1000}$

POWER DELIVERED AT THE MOTOR AXIS

Single-phase: $P_2 \text{ (kW)} = \frac{V \times I \times \cos\varphi \times \eta}{1000}$ or: $P_2 \text{ (HP)} = \frac{V \times I \times \cos\varphi \times \eta}{736}$

Three-phase: $P_2 \text{ (kW)} = \frac{1.73 \times V \times I \times \cos\varphi \times \eta}{1000}$ or: $P_2 \text{ (HP)} = \frac{1.73 \times V \times I \times \cos\varphi \times \eta}{736}$

YIELD

$$\eta = \frac{P_2 \text{ (kW)}}{P_1 \text{ (kW)}}$$

POWER FACTOR

$$\text{Single-phase: } \cos\varphi = \frac{P_2 (\text{kW}) \times 1000}{V \times I \times \eta}$$

$$\text{or: } \cos\varphi = \frac{P_1 (\text{kW}) \times 1000}{V \times I}$$

$$\text{Three-phase: } \cos\varphi = \frac{P_2 (\text{kW}) \times 1000}{1,73 \times V \times I \times \eta}$$

$$\text{or: } \cos\varphi = \frac{P_1 (\text{kW}) \times 1000}{1,73 \times V \times I}$$

TORQUE FACTOR

$$C_n = \frac{P_2 (\text{kW}) \times 1000}{1.027 \times n^{1/\text{min}}} \text{ in kgm}$$

$$C_n = \frac{P_2 (\text{HP}) \times 736}{1.027 \times n^{1/\text{min}}} \text{ in kgm}$$

$$C_n = \frac{702 \times \text{HP}}{n^{1/\text{min}}} \text{ in decaNewtonmetres}$$

RELATIONSHIP BETWEEN KW AND HP

$$1 \text{ HP} = 0,736 \text{ kW}$$

$$1 \text{ kW} = 1,36 \text{ HP}$$

$$\frac{\text{HP}}{1.36} = \text{kW}$$

$$\text{kW} \times 1,36 = \text{HP}$$

STARTING CURRENT (ISP)

The starting current (at switch on) of a motor is 4 to 8 times greater than the nominal current, depending on the power of the motor.

$$I_{sp} = I_n \times 4 \div 8$$

DETAILS ON CAPACITORS

The approximate current absorbed by a capacitor is:

$$I = \frac{6,28 \times F \times C \times V}{1.000.000}$$

Where:

I = current in Amps absorbed by the capacitor.

F = frequency in Hz of the applied voltage.

C = capacity of capacitor μF .

V = applied voltage.

Example:

The current absorbed by a 14 μF capacitor connected to a 220 Volt - 50 Hz power input is:

$$I = \frac{6,28 \times 50 \times 14 \times 220}{1.000.000} = 0,96 \text{ Amperes}$$

The approximate capacity of a capacitor is determined by:

$$C = \frac{I}{6,28 \times F \times V} \times 1.000.000$$

Example:

The capacity of a capacitor that absorbs 1,4 Amperes connected to a 220 Volt - 50 Hz power input is:

$$C = \frac{1,4}{6,28 \times 50 \times 220} \times 1.000.000 = 20,2 \mu\text{F}$$

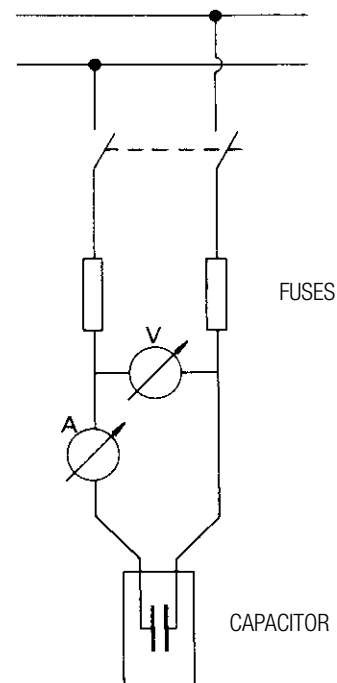

STAR-DELTA START-UP

The normally delta Δ connected motor is connected to the network using a star type connection. The current and the starting torque are both reduced to 1/3 of the value they would be if delta Δ connected.

PROTECTION

It is recommended that motors are connected to the power input network using appropriate three-fuse thermal magnetic circuit breakers, or in any case circuit breakers complying with current local regulations.

TECHNICAL APPENDIX

CENTRIFUGAL ELECTRONIC PUMPS

HEAD LOSS

In centimetres of column water for each metre of straight pipe

V	Q h	PIPE DIAMETER IN mm.																	
		20	25	30	40	50	65	80	100	125	150	175	200	250	300	350	400	450	500
0,5	Q	9,4	14,7	21,2	37,7	59,0	115	151	235	369	530	723	940	1480	2120	2880	3770	4780	5890
	h	2,4	1,9	1,5	1,0	0,8	0,56	0,46	0,36	0,28	0,23	0,19	0,16	0,13	0,105	0,089	0,076	0,067	0,06
0,6	Q	11,3	17,7	25,4	45,3	70,7	138	181	282	442	636	887	1130	1770	2540	3460	4520	5730	7060
	h	3,3	2,6	2,1	1,5	1,12	0,78	0,65	0,5	0,39	0,32	0,27	0,23	0,18	0,15	0,12	0,11	0,096	0,086
0,7	Q	13,2	20,6	29,7	52,9	82,5	161	211	329	516	742	1010	1315	2070	2960	4040	5270	6690	8250
	h	4,4	3,4	2,7	1,9	1,5	1,0	0,86	0,67	0,52	0,43	0,36	0,31	0,24	0,2	0,17	0,15	0,13	0,12
0,8	Q	15,05	23,6	33,9	60,4	94,5	184	241	377	590	848	1155	1505	2360	3390	4620	6030	7650	9420
	h	5,6	4,3	3,4	2,5	1,9	1,3	1,1	0,86	0,67	0,55	0,46	0,4	0,31	0,26	0,22	0,19	0,17	0,15
0,9	Q	16,95	26,5	38,2	68,0	106,0	207	272	423	664	955	1300	1695	2660	3810	5200	6780	8600	10600
	h	6,9	5,3	4,3	3,0	2,4	1,7	1,4	1,1	0,84	0,69	0,58	0,5	0,39	0,32	0,27	0,24	0,21	0,19
1,0	Q	18,8	29,5	42,4	75,5	117,7	230	302	471	737	1060	1445	1880	2950	4230	5770	7530	9550	11770
	h	8,3	6,4	5,1	3,7	2,9	2,1	1,7	1,3	1,0	0,84	0,71	0,61	0,48	0,4	0,34	0,29	0,26	0,23
1,1	Q	20,7	32,4	46,6	83,0	129,5	252	332	518	81	1165	1585	2070	3250	4650	6350	8290	10500	12950
	h	9,9	7,6	6,2	4,4	3,4	2,4	2,0	1,6	1,2	1,0	0,85	0,74	0,58	0,48	0,4	0,35	0,31	0,28
1,2	Q	22,6	35,4	50,9	90,6	141,0	276	362	565	885	1272	1730	2260	3550	5080	6930	9040	11450	14140
	h	11,7	9,0	7,2	5,2	4,0	2,9	2,4	1,9	1,5	1,2	1,0	0,87	0,69	0,56	0,48	0,42	0,37	0,32
1,3	Q	24,5	38,3	55,0	98,0	153,0	299	392	612	960	1378	1875	2450	3840	5500	7500	9800	12400	15320
	h	13,5	10,4	8,4	6,0	4,7	3,3	2,8	2,2	1,71	1,4	1,15	1,0	0,8	0,66	0,56	0,49	0,43	0,38
1,4	Q	26,35	41,3	59,3	105,5	165,0	302	422	660	1032	1473	2020	2635	4140	5920	8090	10530	13370	16500
	h	15,4	11,9	9,6	6,9	5,4	3,8	3,2	2,5	2,0	1,6	1,3	1,17	0,92	0,76	0,64	0,56	0,5	0,44
1,5	Q	28,25	44,2	63,6	113,0	176,5	345	452	707	1106	1590	2165	2825	4430	6350	8660	11300	14320	17680
	h	17,4	13,5	10,9	7,8	6,1	4,4	3,6	2,8	2,25	1,82	1,5	1,34	1,05	0,87	0,74	0,64	0,57	0,51
1,6	Q	30,1	47,1	67,8	121,0	188,5	368	483	753	1180	1695	2310	3010	4730	6770	9240	12055	5015270	18850
	h	19,6	15,3	12,4	8,9	6,9	4,9	4,1	3,2	2,55	2,05	1,7	1,53	1,18	0,99	0,84	0,72	0,64	0,58
1,7	Q	32,0	50,1	72,0	128,0	200,0	392	513	800	1253	1802	2455	3200	5020	7190	9820	12800	16230	20030
	h	21,9	17,2	13,9	10,0	7,8	5,4	4,6	3,6	2,85	2,3	1,95	1,7	1,33	1,11	0,94	0,81	0,73	0,65
1,8	Q	33,9	53,0	76,3	136,0	212,0	415	543	848	1327	1905	2600	3390	5320	7610	10380	13550	17200	21200
	h	24,2	19,1	15,4	11,1	8,7	6,0	5,1	4,0	3,15	2,6	2,2	1,9	1,48	1,24	1,05	0,91	0,81	0,73
1,9	Q	35,8	56,0	80,5	143,5	224,0	438	573	895	1400	2015	2740	3580	5610	8040	10960	14300	18150	22400
	h	26,8	21,0	17,0	12,3	9,6	6,8	5,6	4,4	3,45	2,85	2,45	2,1	1,64	1,38	1,17	1,01	0,9	0,81
2,0	Q	37,7	59,0	84,8	151,0	235,5	461	603	943	1475	2120	2885	3765	5910	8460	11540	15060	19100	23570
	h	29,6	23,0	18,6	13,4	10,5	7,5	6,2	4,9	3,8	3,17	2,7	2,33	1	1,52	1,3	1,12	0,99	0,89
2,1	Q	39,5	62,0	89,0	158,5	247,5	484	633	990	1548	225	3030	3955	6200	8890	12100	15810	20050	24750
	h	32,2	25,1	20,4	14,8	11,5	8,2	6,8	5,4	4,2	3,5	2,95	2,55	2,0	1,68	1,43	1,22	1,08	0,98
2,2	Q	41,5	64,9	93,2	176,0	259,0	507	663	1036	1620	2330	3175	4145	6500	9300	12700	16570	21000	25930
	h	35,0	27,3	22,3	16,2	12,5	9,1	7,4	5,9	4,6	3,85	3,25	2,8	2,2	1,85	1,56	1,34	1,18	1,08
2,3	Q	43,3	67,9	97,5	173,5	271,0	530	694	1082	1695	2440	3320	4330	6800	9730	13270	17310	21950	27100
	h	38,0	29,7	24,2	17,7	13,6	9,8	8,1	6,4	5,0	4,15	3,5	3,05	2,4	2,03	1,7	1,46	1,28	1,18
2,4	Q	45,2	70,8	101,5	181,0	282,5	553	724	1130	1770	2545	3460	4520	7090	10140	13850	18090	22900	28300
	h	42,1	32,1	26,2	19,1	14,7	10,6	8,8	6,9	5,45	4,55	3,8	3,3	2,62	2,21	1,85	1,58	1,38	1,28
2,5	Q	47,1	73,7	105,8	189,0	294,5	576	755	1178	1843	2650	3610	4710	7390	10570	14420	18820	23880	29450
	h	45,0	34,7	28,3	20,5	16,0	11,4	9,6	7,5	5,9	4,9	4,1	3,58	2,84	2,4	2,0	1,7	1,5	1,4
2,6	Q	49,0	76,6	110,0	196,0	306,0	599	785	1225	1915	2755	3755	4900	7680	11000	15000	19590	24820	30630
	h	48,3	37,3	30,4	22,2	17,2	12,3	10,4	8,1	6,35	5,25	4,4	3,85	3,07	2,59	2,17	1,84	1,62	1,51
2,7	Q	50,9	79,6	114,3	204,0	318,0	622	815	1271	1990	2860	3900	5090	7980	111410	15590	20340	25800	31820
	h	51,7	40,0	32,5	23,8	18,5	13,2	11,2	8,7	6,85	5,65	4,75	4,15	3,3	2,78	2,34	1,98	1,74	1,62
2,8	Q	52,7	82,6	118,5	211,5	330,0	645	845	1320	2060	2970	4040	5280	8270	11830	16160	21090	26730	33000
	h	55,2	42,5	34,8	25,5	19,9	14,0	12,0	9,3	7,35	6,05	5,10	4,45	3,56	2,98	2,51	2,13	1,88	1,74
2,9	Q	54,6	85,5	123,0	219,0	342,0	668	875	1365	2140	3075	4190	5460	8560	12250	16730	21480	27700	34200
	h	58,7	45,1	37,1	27,1	21,3	15,2	12,8	10,0	7,85	6,45	5,5	4,75	3,82	3,18	2,7	2,3	2,03	1,87
3,0	Q	56,5	88,5	127,0	226,5	354,0	691	905	1414	2210	3180	4330	5650	8850	12690	17310	22600	28650	35350
	h	62,9	47,9	39,6	28,8	22,6	16,3	13,6	10,7	8,4	6,9	5,9	5,1	4,1	3,4	2,9	2,5	2,2	2,0

HEAD LOSS

in cm of column of water in bends, gate valves, and foot valves

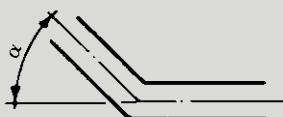
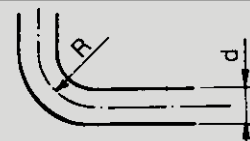
VELOCITY OF WATER IN m/s	SHARP EDGED BENDS					NORMAL BENDS					GATE VALVE	FOOT VALVE	NON-RETURN VALVE	HEAD LOSS ON EXIT FROM DELIVERY PIPES V ² :2G
														
	$\alpha = 30^\circ$	$\alpha = 40^\circ$	$\alpha = 60^\circ$	$\alpha = 80^\circ$	$\alpha = 90^\circ$	$\frac{d}{R} = 0,4$	$\frac{d}{R} = 0,6$	$\frac{d}{R} = 0,8$	$\frac{d}{R} = 1$	$\frac{d}{R} = 1,5$				
0,10	0,03	0,04	0,05	0,07	0,08	0,07	0,08	0,01	0,0155	0,027	0,03	30	30	0,05
0,15	0,06	0,73	0,1	0,14	0,17	0,016	0,019	0,024	0,033	0,06	0,033	31	31	0,12
0,2	0,11	0,13	0,18	0,26	0,31	0,028	0,033	0,04	0,059	0,11	0,058	31	31	0,21
0,25	0,17	0,21	0,28	0,4	0,48	0,044	0,052	0,063	0,091	0,17	0,09	31	31	0,32
0,3	0,25	0,3	0,41	0,6	0,7	0,063	0,074	0,09	0,13	0,25	0,13	31	31	0,46
0,35	0,33	0,4	0,54	0,8	0,93	0,085	0,10	0,12	0,18	0,33	0,18	31	31	0,62
0,4	0,43	0,52	0,71	1,0	1,2	0,11	0,13	0,16	0,23	0,43	0,23	32	31	0,82
0,5	0,67	0,81	1,1	1,6	1,9	0,18	0,21	0,26	0,37	0,67	0,37	33	32	1,27
0,6	0,97	1,2	1,6	2,3	2,8	0,25	0,29	0,36	0,52	0,97	0,52	34	32	1,84
0,7	1,35	1,65	2,2	3,2	3,9	0,34	0,40	0,48	0,70	1,35	0,7	35	32	2,5
0,8	1,7	2,1	2,8	4,0	4,8	0,45	0,53	0,64	0,93	1,7	0,95	36	33	3,3
0,9	2,2	2,7	6	5,2	6,2	0,57	0,67	0,82	1,18	2,2	1,2	37	34	4,2
1,0	2,7	3,3	4,5	6,4	7,6	0,7	0,82	1,0	1,45	2,7	1,45	38	35	5,1
1,5	6,0	7,3	10,0	14,0	17,0	1,6	1,9	2,3	3,3	6,0	3,3	47	40	11,5
2,0	11,0	14,0	18,0	26,0	31,0	2,8	3,3	4,0	5,8	11,0	5,8	61	48	20,4
2,5	17,0	21,0	28,0	40,0	48,0	4,4	5,2	6,3	9,1	17,0	9,1	78	58	32,0
3,0	25,0	30,0	41,0	60,0	70,0	6,3	7,4	9,0	13,0	25,0	13,0	100	71	46,0
3,5	33,0	40,0	55,0	78,0	93,0	8,5	10,0	12,0	18,0	33,0	18,0	123	85	62,0
4,0	43,0	52,0	70,0	100,0	120,0	11,0	13,0	16,0	23,0	42,0	23,0	150	100	82,0
4,5	55,0	67,0	90,0	130,0	160,0	14,0	21,0	26,0	37,0	55,0	37,0	190	120	103,0
5,0	67,0	82,0	110,0	160,0	190,0	18,0	29,0	36,0	52,0	67,0	52,0	220	140	127,0

Q = flow rate in l/min

v = velocity of water in metres per second

d = diameter of pipes in metres

h = head loss in cm of water column for each metre of pipework, calculated according to the Lang formula:

$$h = \lambda \times \frac{100}{d} \times \frac{v^2}{2g} \quad \lambda = 0,02 + \frac{0,0018}{\sqrt{v \times d}}$$

The only loss in bends is that due to the contraction of the liquid stream when changing direction (the development of the curves must therefore be included in the length of the pipework); the head loss for gate valves has been determined through technical tests.

The head loss for gate valves and normal bends is equal to that of 5 m of straight pipework, while that of non-return valves is equal to 15 m.

The values given are for pipes with a completely smooth internal surface. In case of rough or scaled pipes, allowances must be made accordingly.

TECHNICAL APPENDIX

CENTRIFUGAL ELECTRONIC PUMPS

VAPOUR TENSION AND SPECIFIC WEIGHT OF WATER AS A FUNCTION OF TEMPERATURE

t °C	pv kg/cm ²	γ kg/dm ³	t °C	pv kg/cm ²	γ kg/dm ³	t °C	pv kg/cm ²	γ kg/dm ³	t °C	pv kg/cm ²	γ kg/dm ³
00	0,0062	0,9998	41	0,793	0,9917	82	0,5234	0,9705	170	008,076	0,8973
01	0,0067	0,9999	42	0,836	0,9913	83	0,5447	0,9698	175	009,101	0,8920
02	0,0072	0,9999	43	0,881	0,9909	84	0,5667	0,9693	180	010,225	0,8869
03	0,0077	1,0000	44	0,928	0,9905	85	0,5897	0,9687	185	011,456	0,8814
04	0,0083	1,0000	45	0,977	0,9900	86	0,6129	0,9680	190	012,800	0,8760
05	0,0089	1,0000	46	0,1028	0,9898	87	0,6372	0,9673	195	014,265	0,8703
06	0,0095	0,9999	47	0,1082	0,9883	88	0,6623	0,9667	200	015,857	0,8646
07	0,0102	0,9999	48	0,1138	0,9889	89	0,6882	0,9659	205	017,858	0,8587
08	0,0109	0,9998	49	0,1197	0,9885	90	0,7149	0,9653	210	019,456	0,8528
09	0,0117	0,9997	50	0,1258	0,9880	91	0,7425	0,9646	215	021,477	0,8465
10	0,0125	0,9996	51	0,1322	0,9876	92	0,7710	0,9640	220	023,659	0,8403
11	0,0134	0,9995	52	0,1388	0,9871	93	0,8004	0,9632	225	026,007	0,8339
12	0,0143	0,9994	53	0,1457	0,9866	94	0,8307	0,9625	230	028,531	0,8272
13	0,0153	0,9993	54	0,1530	0,9861	95	0,8619	0,9619	235	031,239	0,8206
14	0,0163	0,9992	55	0,1605	0,9857	96	0,8942	0,9611	240	034,140	0,8136
15	0,0174	0,9990	56	0,1683	0,9852	97	0,9271	0,9604	245	037,244	0,8064
16	0,0185	0,9989	57	0,1765	0,9847	98	0,9616	0,9596	250	040,560	0,7992
17	0,0197	0,9987	58	0,1850	0,9842	99	0,9969	0,9590	255	044,100	0,7918
18	0,0210	0,9985	59	0,1939	0,9836	100	1,0032	0,9583	260	047,870	0,7840
19	0,0224	0,9984	60	0,2031	0,9831	102	1,1092	0,9568	265	051,880	0,7759
20	0,0238	0,9982	61	0,2127	0,9826	104	1,1898	0,9554	270	056,140	0,7678
21	0,0253	0,9979	62	0,2227	0,9821	106	1,2751	0,9540	275	060,660	0,7593
22	0,0269	0,9977	63	0,2330	0,9816	108	1,6354	0,9525	280	065,460	0,7506
23	0,0286	0,9974	64	0,2438	0,9810	110	1,4609	0,9510	285	070,540	0,7416
24	0,0304	0,9972	65	0,2550	0,9804	112	1,5618	0,9495	290	075,920	0,7323
25	0,0323	0,9970	66	0,2666	0,9800	114	1,6684	0,9479	286	081,600	0,7227
26	0,0343	0,9966	67	0,2787	0,9794	116	1,7809	0,9464	300	087,610	0,7214
27	0,0363	0,9964	68	0,2912	0,9788	118	1,8995	0,9448	305	093,950	0,7017
28	0,0385	0,9961	69	0,3042	0,9782	120	2,0245	0,9431	310	100,640	0,6906
29	0,0408	0,9957	70	0,3177	0,9777	122	2,1561	0,9414	315	107,690	0,6793
30	0,0432	0,9955	71	0,3317	0,9771	124	2,2947	0,9398	320	115,130	0,6671
31	0,0458	0,9952	72	0,3463	0,9765	126	2,4404	0,9381	325	122,950	0,6540
32	0,0485	0,9949	73	0,3613	0,9759	128	2,5935	0,9365	330	131,180	0,6402
33	0,0513	0,9946	74	0,3869	0,9754	130	2,7544	0,9348	335	139,850	0,6257
34	0,0542	0,9942	75	0,3931	0,9748	135	3,1920	0,9305	340	148,960	0,6093
35	0,0573	0,9939	76	0,4098	0,9742	140	3,6850	0,9260	345	157,540	0,5910
36	0,0606	0,9934	77	0,4274	0,9737	145	4,2370	0,9216	350	168,630	0,5724
37	0,0640	0,9932	78	0,4451	0,9730	150	4,8540	0,9169	355	179,240	0,5512
38	0,0675	0,9928	79	0,4637	0,9724	155	5,5400	0,9121	360	190,420	0,5243
39	0,0713	0,9925	80	0,4829	0,9718	160	6,3020	0,9073	365	202,210	0,4926
40	0,0752	0,9921	81	0,5028	0,9712	165	7,1460	0,9023	370	214,680	0,4484

ATMOSPHERIC PRESSURE AT VARIOUS HEIGHTS

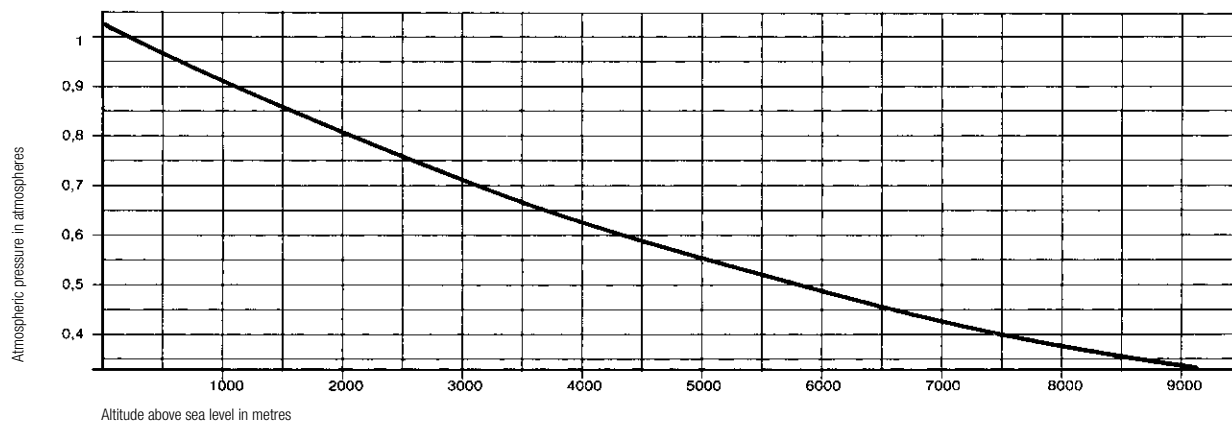

TECHNICAL APPENDIX

CENTRIFUGAL ELECTRONIC PUMPS

FLOW RATE OF WATER FROM NOZZLES AND FIRE HOSES IN l/s AS A FUNCTION OF THE PRESSURE MEASURED UPSTREAM THE NOZZLE, IN METRES OF COLUMN OF WATER.

Ø NOZZLE IN mm	PRESSURE in m.c.w.												
	4	6	8	10	12	14	16	18	20	22	24	26	28
1	0,0068	0,0083	0,0096	0,0107	0,0118	0,0127	0,0136	0,0144	0,0152	0,0159	0,0167	0,0174	0,018
2	0,273	0,0334	0,0386	0,0432	0,0473	0,0511	0,0546	0,0579	0,0611	0,064	0,0668	0,696	0,0722
3	0,614	0,0751	0,0868	0,097	0,1063	0,1148	0,1228	0,13	0,137	0,144	0,15	0,156	0,162
4	0,109	0,133	0,154	0,175	0,189	0,204	0,218	0,231	0,244	0,255	0,267	0,278	0,288
5	1,171	0,209	0,242	0,271	0,296	0,32	0,342	0,363	0,383	0,401	0,419	0,4336	0,453
6	0,246	0,301	0,348	0,389	0,426	0,455	0,492	0,522	0,55	0,577	0,603	0,627	0,652
7	0,334	0,408	0,472	0,527	0,578	0,625	0,667	0,708	0,747	0,783	0,817	0,851	0,883
8	0,436	0,534	0,616	0,689	0,755	0,815	0,871	0,925	0,975	1,022	1,067	1,11	1,152
9	0,553	0,677	0,782	0,875	0,958	1,035	1,107	1,172	1,236	1,297	1,355	1,41	1,461
10	0,684	0,836	0,966	1,08	1,183	1,27	1,368	1,448	1,523	1,6	1,672	1,742	1,808
11	0,83	1,017	1,173	1,313	1,439	1,555	1,66	1,76	1,855	1,99	2,03	2,117	2,196
12	0,982	1,2	1,387	1,55	1,7	1,87	1,964	2,08	2,19	2,3	2,4	2,5	2,59
13	1,154	1,412	1,63	1,825	2,0	2,16	2,31	2,45	2,58	2,7	2,83	2,94	3,05
14	1,337	1,635	1,89	2,113	2,313	2,5	2,67	2,834	2,99	3,135	3,27	3,41	2,538
15	1,535	1,88	2,17	2,417	2,66	2,87	3,07	3,25	3,43	3,6	3,76	3,91	4,06
16	1,742	2,132	2,464	2,757	3,02	3,26	3,486	3,7	3,9	4,08	4,27	4,45	4,62
17	1,97	2,413	2,787	3,119	3,417	3,686	3,947	4,18	4,41	4,62	4,83	58,025	5,21
18	2,21	2,703	3,125	3,499	3,83	4,13	4,42	4,68	4,94	5,18	5,42	5,64	5,85
20	2,73	3,34	3,86	4,32	4,73	5,11	5,46	5,78	6,11	6,4	6,78	6,96	7,23
22	3,298	4,04	4,66	5,22	5,72	6,17	6,75	7,0	7,48	7,74	8,07	8,4	8,8
25	4,265	5,22	6,02	6,74	7,38	7,87	8,52	9,04	9,53	9,99	10,42	10,85	11,25
26	4,6	5,64	6,5	7,27	7,97	8,61	9,2	9,76	10,28	10,69	11,27	11,71	12,16
28	5,36	6,56	7,56	8,46	9,28	10,2	10,7	11,36	11,9	12,55	13,12	13,64	14,09
32	6,97	8,55	9,85	11,02	12,08	13,05	13,93	14,8	15,6	16,7	17,2	17,79	18,44
35	8,358	10,23	11,8	13,2	14,45	15,6	16,7	17,7	18,68	19,59	20,43	21,26	22,09
45	13,8	16,9	19,5	21,82	23,9	25,84	27,6	29,3	30,9	32,39	33,8	35,2	26,5
55	20,3	25,2	28,5	32,6	35,7	38,6	41,2	44,0	46,1	48,3	50,5	52,6	54,5
65	28,5	34,8	40,2	45,0	49,3	53,4	56,9	60,5	63,6	66,6	69,7	72,6	75,4
75	38,3	46,9	54,2	60,6	66,4	71,7	76,6	81,4	85,6	90,0	93,9	97,7	101,4
85	49,4	60,5	69,7	77,0	85,5	92,4	98,7	104,7	110,3	115,7	121,0	125,0	130,5
95	61,5	75,4	87,0	97,4	106,5	115,2	123,0	130,5	137,6	143,3	150,8	157,0	162,8

Ø NOZZLE IN mm	PRESSURE in m.c.w.												
	4	6	8	10	12	14	16	18	20	22	24	26	28
1	0,0068	0,0083	0,0096	0,0107	0,0118	0,0127	0,0136	0,0144	0,0152	0,0159	0,0167	0,0174	0,018
2	0,273	0,0334	0,0386	0,0432	0,0473	0,0511	0,0546	0,0579	0,0611	0,064	0,0668	0,696	0,0722
3	0,614	0,0751	0,0868	0,097	0,1063	0,1148	0,1228	0,13	0,137	0,144	0,15	0,156	0,162
4	0,109	0,133	0,154	0,175	0,189	0,204	0,218	0,231	0,244	0,255	0,267	0,278	0,288
5	1,171	0,209	0,242	0,271	0,296	0,32	0,342	0,363	0,383	0,401	0,419	0,4336	0,453
6	0,246	0,301	0,348	0,389	0,426	0,455	0,492	0,522	0,55	0,577	0,603	0,627	0,652
7	0,334	0,408	0,472	0,527	0,578	0,625	0,667	0,708	0,747	0,783	0,817	0,851	0,883
8	0,436	0,534	0,616	0,689	0,755	0,815	0,871	0,925	0,975	1,022	1,067	1,11	1,152
9	0,553	0,677	0,782	0,875	0,958	1,035	1,107	1,172	1,236	1,297	1,355	1,41	1,461
10	0,684	0,836	0,966	1,08	1,183	1,27	1,368	1,448	1,523	1,6	1,672	1,742	1,808
11	0,83	1,017	1,173	1,313	1,439	1,555	1,66	1,76	1,855	1,99	2,03	2,117	2,196
12	0,982	1,2	1,387	1,55	1,7	1,87	1,964	2,08	2,19	2,3	2,4	2,5	2,59
13	1,154	1,412	1,63	1,825	2,0	2,16	2,31	2,45	2,58	2,7	2,83	2,94	3,05
14	1,337	1,635	1,89	2,113	2,313	2,5	2,67	2,834	2,99	3,135	3,27	3,41	2,538
15	1,535	1,88	2,17	2,417	2,66	2,87	3,07	3,25	3,43	3,6	3,76	3,91	4,06
16	1,742	2,132	2,464	2,757	3,02	3,26	3,486	3,7	3,9	4,08	4,27	4,45	4,62
17	1,97	2,413	2,787	3,119	3,417	3,686	3,947	4,18	4,41	4,62	4,83	58,025	5,21
18	2,21	2,703	3,125	3,499	3,83	4,13	4,42	4,68	4,94	5,18	5,42	5,64	5,85
20	2,73	3,34	3,86	4,32	4,73	5,11	5,46	5,78	6,11	6,4	6,78	6,96	7,23
22	3,298	4,04	4,66	5,22	5,72	6,17	6,75	7,0	7,48	7,74	8,07	8,4	8,8
25	4,265	5,22	6,02	6,74	7,38	7,87	8,52	9,04	9,53	9,99	10,42	10,85	11,25
26	4,6	5,64	6,5	7,27	7,97	8,61	9,2	9,76	10,28	10,69	11,27	11,71	12,16
28	5,36	6,56	7,56	8,46	9,28	10,2	10,7	11,36	11,9	12,55	13,12	13,64	14,09
32	6,97	8,55	9,85	11,02	12,08	13,05	13,93	14,8	15,6	16,7	17,2	17,79	18,44
35	8,358	10,23	11,8	13,2	14,45	15,6	16,7	17,7	18,68	19,59	20,43	21,26	22,09
45	13,8	16,9	19,5	21,82	23,9	25,84	27,6	29,3	30,9	32,39	33,8	35,2	26,5
55	20,3	25,2	28,5	32,6	35,7	38,6	41,2	44,0	46,1	48,3	50,5	52,6	54,5
65	28,5	34,8	40,2	45,0	49,3	53,4	56,9	60,5	63,6	66,6	69,7	72,6	75,4
75	38,3	46,9	54,2	60,6	66,4	71,7	76,6	81,4	85,6	90,0	93,9	97,7	101,4
85	49,4	60,5	69,7	77,0	85,5	92,4	98,7	104,7	110,3	115,7	121,0	125,0	130,5
95	61,5	75,4	87,0	97,4	106,5	115,2	123,0	130,5	137,6	143,3	150,8	157,0	162,8

TECHNICAL APPENDIX

CENTRIFUGAL ELECTRONIC PUMPS

CONVERSION TABLE FOR UNITS OF MEASURE

CHARACTERISTIC	SYSTEM UNIT OF MEASURE	UNIT OF MEASURE	SYMBOL	CONVERSIONS		
				SYSTEM	INTERNATIONAL SYSTEM (SI)	IMPERIAL SYSTEM
LENGTH	Technical and International	metre decimetre centimetre millimetre	m dm cm mm	1 dm = 0,1 m 1 cm = 0,01 m 1 mm = 0,001 m		1 m = 3,28 ft 1 dm = 3,937 in 1 cm = 0,3937 in
	Imperial	inch foot yard	1", in 1", ft yd	1" = 25,4 mm 1" ft = 0,3048 m 1 yd = 0,9144 m		1 ft = 12" 1 yd = 3 ft = 26"
AREA	Technical and International	metres squared centimetres squared millimetres squared	m ² cm ² mm ²	1 cm ² = 0,0001 m ² 1 mm ² = 0,01 cm ²		1 m ² = 1,196 sq.yd 1 m ² = 10,764 sq.ft 1 cm ² = 0,155 sq.in
	Imperial	square inch square foot square yard	sq.in sq.ft sq.yd	1 sq.in = 6,45 cm ² 1 sq.ft = 0,0929 m ² 1 sq.yd = 0,836 m ²		1 sq.ft = 144 sq.in 1 sq.yd = 1,296 sq.in 1 sq.yd = 9 sq.ft
VOLUME	Technical and International	metre cubed decimetre cubed centimetre cubed litre cubed	m ³ cm ³ mm ³ l	1 m ³ = 1,000 dm ³ 1 cm ³ = 0,001 m = 1.000 cm ³ 1 mm ³ = 0,001 dm ³ 1 l = dm ³		1 dm ³ = 0,22 Imp.gal 1 dm ³ = 0,264 US.gal 1 dm ³ = 61,0 cu.in
	Imperial	cubic inch cubic feet Imperial gallons U.S. gallons	cu.in cu.ft Imp.gal USA.gal	1 cu.in = 16,39 cm ³ 1 cu.ft = 28,34 m ³ 1 Imp.gal = 4,546 m ³ 1 US.gal = 3,785 dm ³		1 Imp.gal = 1,201 US.gal 1 US.gal = 0,833 Imp.gal
TEMPERATURE	Technical and International	degrees Centigrade degrees Kelvin	°C °K	°C = °K - 273 °K = °C + 273		°C = 5/9 x (°F - 32) °K = 5/9 x (°F - 32) + 273
	Imperial	degrees Fahrenheit	°F	°F = 9/5 x °C + 32		-
		freezing point of water at atmospheric pressure: boiling point of water at atmospheric pressure:		0 °C = 273 °K = 032 °F 100 °C = 373 °K = 212 °F		
WEIGHT and FORCE	Technical	kilogram	kg	-	1 kg = 9,81 N	1 kg = 2,203 lb
	International	Newton	N	1 N = 0,102 kg	-	1 N = 0,22546 lb
	Imperial	pound	lb	1 lb = 0,454 kg	1 lb = 4,452 N	-
SPECIFIC WEIGHT	Technical	kilogram per decimetre cubed	kg/dm ³	-	1 kg/dm ³ = 9,807 N/dm ³	1 kg/dm ³ = 62,46 lb/cu.ft
	International	Newton per decimetre cubed	N/dm ³	1 N/dm ³ = 0,102 kg/dm ³	-	1 N/dm ³ = 6,36 lb/cu.ft
	Imperial	pound per cubic foot	lb/dm ³	1 lb/cu.ft = 0,01600 kg/dm ³	1 lb/cu.ft = 0,160 N/dm ³	-
PRESSURE	Technical	atmospheres	kg/cm ²	-	1 kg/cm ² = 98,067 kPa 1 kg/cm ² = 0,9807 bar	1 kg/cm ² = 14,22 psi
	International	Pascal kiloPascal bar	Pa kPa bar	1 kPa = 0,0102 kg/cm ² 1 bar = 1,02 kg/cm ²	1 kPa = 1.000 Pa 1 bar = 100.000 Pa	1 kPa = 0,145 psi 1 bar = 14,50 psi
	Imperial	pounds per square inch	psi	1 psi = 0,0703 kg/cm ²	1 psi = 0,06895 bar 1 psi = 6,894 kPa	-
FLOW	Technical	litres per minute litres per second metres cubed per hour	l/min l/s m ³ /h	1 l/min = 0,0167 l/s 1 l/s = 3,6 m ³ /h 1 m ³ /h = 16,667 l/min	1 l/s = 0,001 m ³ /s	1 l/min = 0,22 imp.g.p.m. 1 l/min = 0,264 US.g.p.m. 1 m ³ /h = 3,666 imp.g.p.m. 1 m ³ /h = 4,403 US.g.p.m.
	International	metres cubed per second	m ³ /s	1 m ³ /s = 1.000 l/s 1 m ³ /s = 3.600 m ³ /h	-	1 m ³ /s = 13,198 imp.g.p.m. 1 m ³ /s = 15,852 US.g.p.m.
	Imperial	imperial gallons per minute U.S. gallons per minute	Imp.g.p.m. US.g.p.m.	1 Imp.g.p.m. = 4,546 l/min 1 Imp.g.p.m. = 0,273 m ³ /h 1 US.g.p.m. = 3,785 l/min 1 US.g.p.m. = 0,227 m ³ /h	-	1 Imp.g.p.m. = 1,201 US.g.p.m. 1 US.g.p.m. = 0,833 Imp.g.p.m.
TORQUE TORCENTE	Technical	kilogram metre	kgm	-	1 kgm = 9,807 Nm	1 kgm = 7,233 ft.lb
	International	Newton metre	Nm	1 Nm = 0,102 kgm	-	1 Nm = 0,7376 ft.lb
	Imperial	foot pound	ft.lb	1 ft.lb = 0,138 kgm	1 ft.lb = 1,358 Nm	-
WORK and ENERGY	Technical	kilogram metre vapour-horsepower hour	kgm CVh		1 kgm = 9,807 J 1 CVh = 0,736 kWh	1 kgm = 7,233 ft.lb 1 Nm = 0,986 HP.hr.
	International	Joule kiloWatt hour	J kWhq	1 J = 0,102 kgm kWh = 1,36 CVh	-	1 Nm = 0,7376 ft.lb 1 Nm = 0,7376 ft.lb
	Imperial	foot pound Horsepower hour	ft.lb HP.hr.	1 ft.lb = 0,138 kgm 1 HP.hr. = 1,014 CVh	1 ft.lb = 0,358 Nm 1 HP.hr. = 0,746 kWh	-
POWER	Technical	Horse power	HP	1 HP = 0,736 kW	1 HP = 736 W	-
	International	Watt kiloWatt	W kW	1 W = 0,00136 Hp 1 kW = 1,36 Hp	1 kW = 1.000 W	-
KINETIC VISCOSITY	Technical	stokes centistokes	1 St 1 cSt	1 St = 1 cm ² /s 1 cSt = 0,01 St	1 St = 0,0001 m ² /s	1 St = 0,00107 ft ² /s
	International	m ² /s	m ² /s	1 m ² /s = 10.000 St	1 m ² /s = 10.000 cm ² /s	1 m ² /s = 10,764 ft ² /s
	Imperial	square foot per second	ft ² /s	1 ft ² /s = 929 St	1 ft ² /s = 0,0929 m ² /s	-

TECHNICAL APPENDIX

CENTRIFUGAL ELECTRONIC PUMPS

TABLE OF EQUIVALENT STANDARDS FOR MATERIALS

MATERIAL	UNI		DIN		ISO	AISI	ASTM
STEEL	X 30Cr13	UNI 6900/71	X 30Cr13	DIN 17440	-	AISI 420B	-
	X 12CrS13	UNI 6900/71	X 12CrS13	DIN 17440	-	AISI 416	-
	X 20Cr13	UNI 6900/71	X 20Cr13	DIN 17440	-	AISI 420A	S 42000 A 276
	X 10CrNiS1809	UNI 6900/71	X 10CrNiS1809	DIN 17440	XIII-17 ISO 683/XIII	AISI 303	S 30300 A 276
	X 5CrNi 1810	UNI 6900/71	X 5CrNi 1810	DIN 17440	XIII-11 ISO 683/XIII	AISI 304	S 30400 A 276
	X 10CrS17	UNI 6900/71	X 10CrS17	DIN 17440	XIII-84 ISO 683/XIII	AISI 430F	-
CAST IRON	G 20	UNI ISO 185	GG 20	DIN 1691	Grade 20 ISO R 185	-	Class 25 A 48
	G 25	UNI ISO 185	GG 25	DIN 1691	Grade 20 ISO R 185	-	Class 35 A 48
BRASS	G CuZn38Al 1Fe 1Mni	UNI 6138/68	-	-	-	-	B 30 C 86550
	P CuZn40 Pb2	UNI 5705	P CuZn40 Pb2	DIN 17660	-	-	C 37740
BRONZE	G CuSn12	UNI 7013/72	G CuSn12	DIN 17006	CuSn 12 ISO 1338	-	B 205 C 90700

CHART FOR THE SELECTION OF THE POWER INPUT CABLE IN RELATION TO LENGTH

Voltage 1 x 230 V ~ direct start
3 % voltage drop
Ambient temperature 30 °C

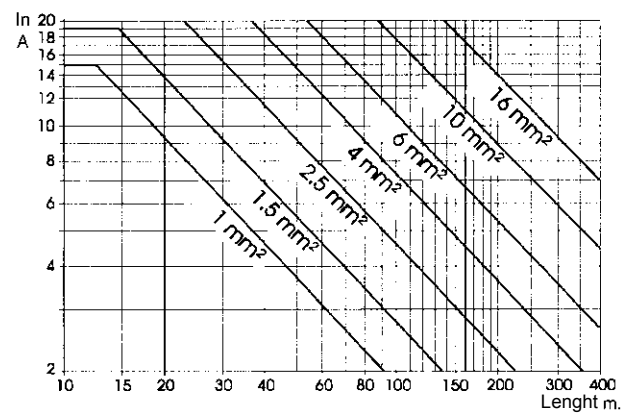

Voltage 3 x 400 V ~ direct start
3 % voltage drop
Ambient temperature 30 °C

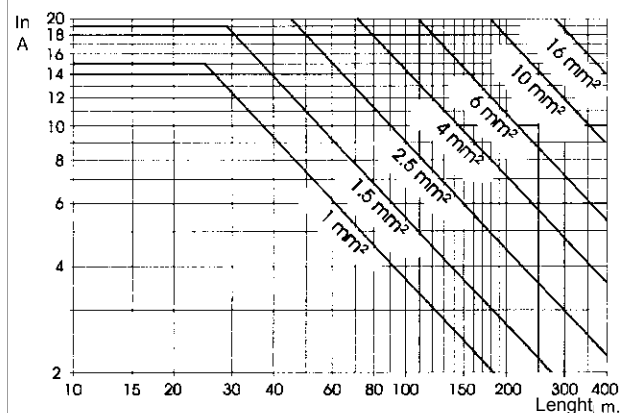

EXPLANATION OF PUMP DATA PLATES

N.	SERIAL NUMBER	-
Q	FLOW	m³/h
H	HEAD	m
H max	MAXIMUM HEAD	m
H min	MINIMUM HEAD	m
-	REVOLUTIONS PER MINUTE	1/min
-	ABSORBED POWER	kWass
-	NOMINAL DEVELOPED POWER	HP
-	VOLTAGE	V ~
-	FREQUENCY	Hz
-	CURRENT	A
-	PROTECTION CLASS (IEC)	IP
I.C.L.	INSULATION CLASS	µF Vc
-	CAPACITY AND VOLTAGE OF CAPACITOR	µF Vc
▽m	MAXIMUM IMMERSION	m
LWA	NOISE LEVEL	dB

DAB					
WATER TECHNOLOGY					
DAB PUMPS S.p.A. Via Marco Polo, 14 35035 Mestrino (PD) - Italy					
N.		TF S1			
Q	m³/h	H	m		HP
Hmax	m	Hmin	m	I.C.L. F	kW ass.
1/min	IP	Hz	µF	V~	MADE IN ITALY

TECHNICAL APPENDIX

CENTRIFUGAL ELECTRONIC PUMPS

WIRING DIAGRAMS FOR ELECTRIC MOTORS

SINGLE-PHASE

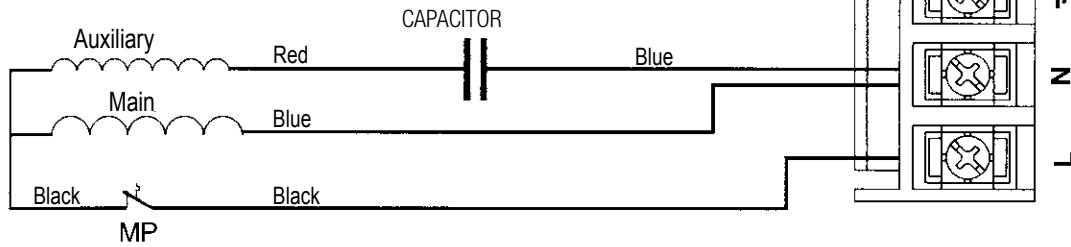

Overload protection inside the winding - MEC 63-71 M

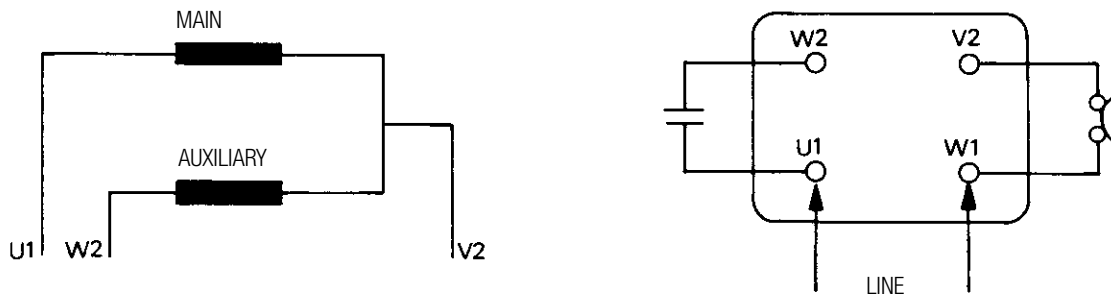

Overload protection inside the terminal board - MEC 80 M

THREE-PHASE

3 ~ 230/400 V

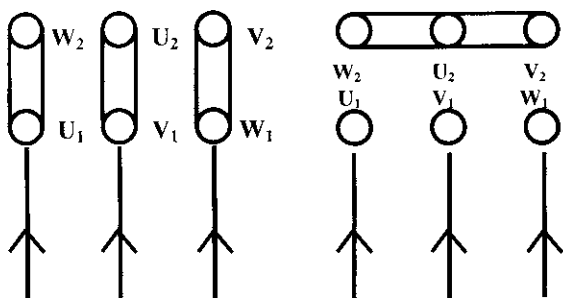

Power input line
230 V

400 V

TRIANGLE connection

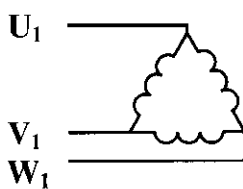

STAR connection

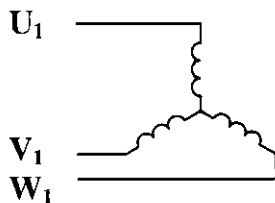

3 ~ 400 Δ V

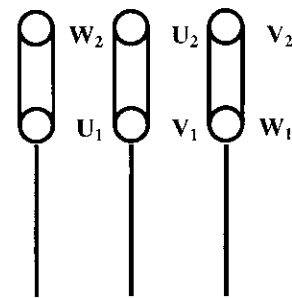

Power input line

DELTA connection

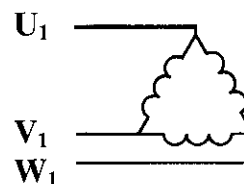

Clockwise rotation when viewed from the fan end

4 - Electric connections for inputs and outputs

The MCE/C has 2 digital inputs, one analogue input and 2 digital outputs, in order to make it possible to obtain some interface solutions with more complex systems.

4.1 - Digital Inputs

On the base of the 18-pole terminal board is the indication of the digital inputs:

- 11 - V+
- 15 - I2
- 16 - I1/I2
- 17 - I1
- 18 - GND

The switching on of the inputs is possible both in direct and in alternate current. Below are the electric characteristics of the inputs.

Electrical characteristics of the inputs		
	DC inputs [V]	AC inputs [Vrms]
Minimum switch-on voltage [V]	8	6
Maximum switch-off voltage [V]	2	1,5
Maximum permitted voltage [V]	36	36
Current absorbed at 12 V [mA]	3,3	3,3
Max cable section accepted [mm ²]	2,13	
<i>Note: the inputs can be driven with any polarity (positive or negative in relation to their own mass return)</i>		

* to check the availability of the function on specific models contact our customer service.

The example proposed refers to a connection with clean contact, using the internal voltage for driving the input.

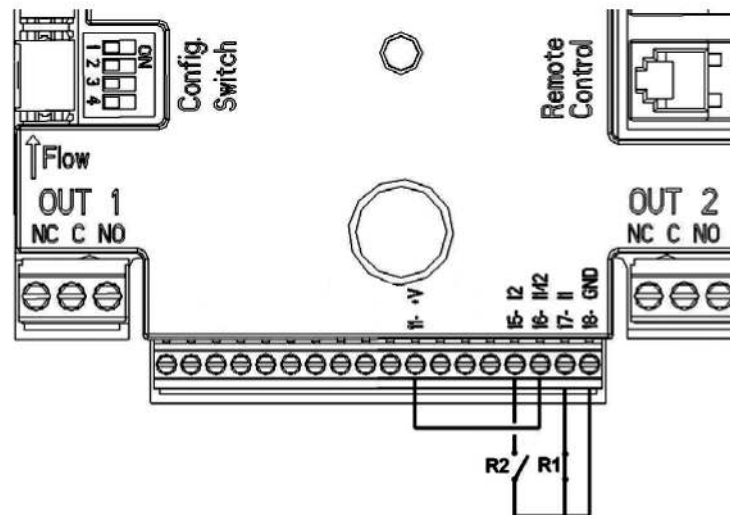

Digital Input Connection Example

If a voltage is available, rather than a contact, this can also be used to drive the inputs: simply do not use the +V and GND terminals, and connect the voltage source to the desired input, complying with the characteristics described above.

Functions associated to the digital inputs	
I1	Start/Stop: If input 1 is activated from the control panel, it will be possible to remotely control the switching on and off of the pump.
I2	Economy: If input 2 is activated from the control panel, it will be possible to remotely activate the set-point reduction function.

R1	R2	System Status
Open	Open	Pump stopped OFF
Open	Close	Pump stopped OFF
Open	Open	Pump in operation with AUTO set-point set by the user
Open	Close	Pump in operation with reduced ECONOMY set-point

4.2 - Outputs:

The connections of the outputs listed below are for the two 3-pole terminal boards indicated with **OUT1** and **OUT2**, under which the type of contact relating to the connection terminal is also indicated (**NC** = Normally Closed, **C** = Common, **NO** = Normally Open).

Characteristics of the output contacts	
Type of contact	NO, NC, COM
Max sustainable voltage [V]	250
Max sustainable current [A]	5 If resistive load 2,5 If inductive load
Max cable section accepted [mm ²]	3,80

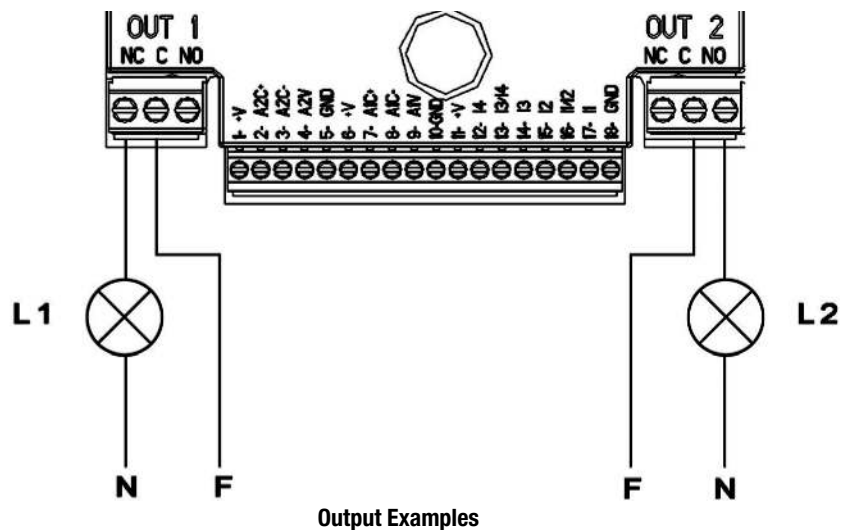

In the example shown, light L1 comes on when the system includes an alarm, and goes off when no faults are detected, while light L2 comes on when the pump is in operation, and goes off when the pump is stopped.

Functions associated to the outputs	
OUT1	Presence/absence of system alarms
OUT2	Pump in operation/Pump stopped

4.3 - Analogue input for driving the Constant Curve Mode with External Analogue Signal

On the base of the 18-pole terminal board is the indication of the 0-10 V analogue input:

- A1V (terminal 9): Positive pole
- GND (terminal 10): Negative pole

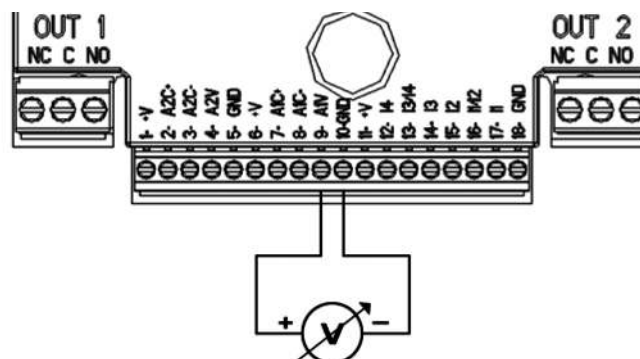

Analogue Input Connection Example

The function associated to the 0-10 V analogue input is the **adjustment of the rotation speed of the pump in proportion to the 0-10 V power input voltage itself.**

5 - Twin function

It is possible to create pumping groups with a maximum of 2 pumps. In order to do this, it is necessary to hydraulically connect the pumps on the same delivery and suction manifolds. For twin circulators, this operation is of course not necessary.

It is also necessary to connect the 2 MCE/C inverters using the appropriate interconnection cable, connected to both inverters, using one of the 2 connectors marked with **Link**.

For correct operation of the twin system, it is necessary that all the input terminal board external connections are in parallel between the 2 MCE/C, complying with the numerations of the individual terminals (e.g. terminal 17 of the MCE-22/C-1 with terminal 17 of MCE-22/C-2, and so on).

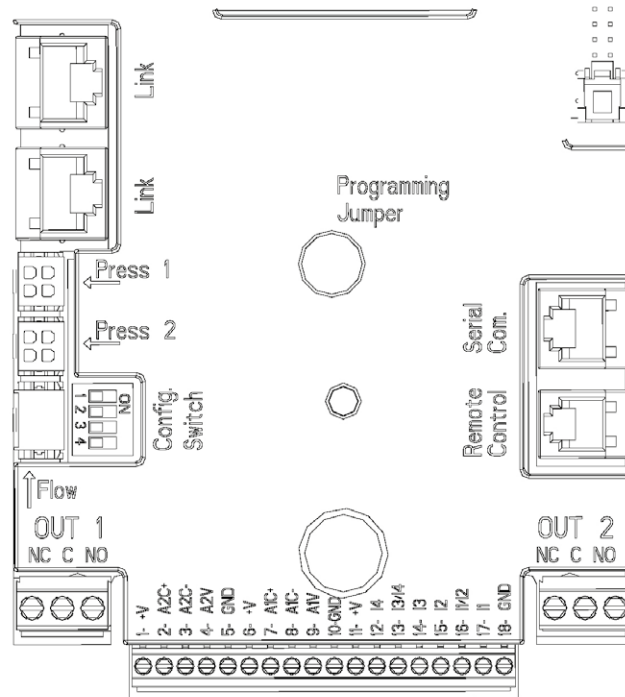

5.1 - Software set-up

When using a twin system, using page 7.0 of the menu it is possible to set one of the 3 available twin operating modes:

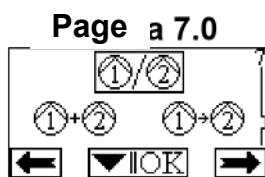

Alternate every 24 hours: The 2 inverters alternate in performing the adjustment functions at intervals of 24 hours of operation. If one becomes faulty, the other one takes over the adjustment operations.



Simultaneous: The 2 inverters both work at the same time, and at the same speed. This mode is useful when a flow rate that cannot be delivered by one single pump is required.



Main/Backup: The adjustment is always performed by the same inverter (Main); the other one (Backup) only intervenes when the Main one becomes faulty.

If the twin communication cable is connected, the systems are automatically configured as individual, working in a full independent way from each other.

6 - Single-phase electric connection diagram (up to MCE-22/C)

6.1 - Connection to the power input line

The connection between the single-phase power input line and the MCE-22/C must be completed using a 3-wire cable (phase + neutral + ground). The input terminals are marked with LINE LN and an arrow entering the terminals; see Figure 1

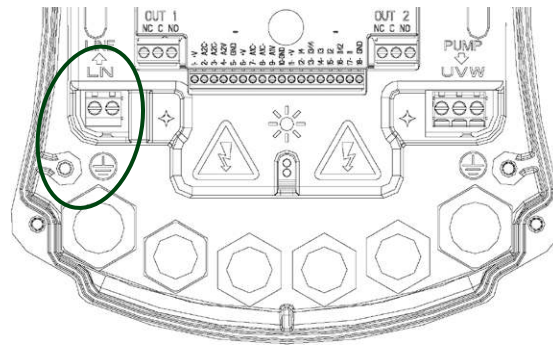

Figure 1: Electric Connections

The minimum section of the input and output cables must be such to ensure correct tightening of the cable glands, while the maximum section accepted by the terminals is 4 mm²

The current at the electric pump is generally specified in the motor data plates.

The maximum power input current at the MCE-22/C can be estimated in general as double in relation to the maximum current absorbed by the pump. Although the MCE-22/C is already fitted with internal protections, it is recommended that a protection thermal magnetic circuit breaker of appropriate size is also installed.

6.2 - Three-phase electric connection diagram (MCE-30/C and MCE-55/C)

6.3 - Connection to the power input line

The connection between the three-phase power input line and the MCE-30/C and MCE-55/C must be completed using a 4-wire cable (3 phases + ground). The input terminals are marked with LINE RST and an arrow entering the terminals; see Figure 2

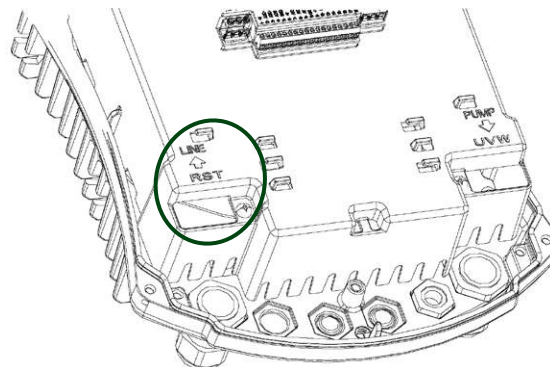

Figure 2: Electric Connections

The maximum section accepted by the input and output terminals is 6 mm².

The external diameter of the input and output cables accepted by the cable glands for appropriate tightening goes from 11 mm² minimum, to 17 mm² maximum.

The current at the electric pump is generally specified in the motor data plates.

The MCE-55/C power input current can be generally assessed (with a safety margin) as 1/8 more than the current absorbed by the pump. Although the MCE-55/C is already fitted with internal protections, it is recommended that a protection thermal magnetic circuit breaker of appropriate size is also installed.

6.4 - Three-phase electric connection diagram (MCE-110/C and MCE150/C)

6.5 - Connection to the power input line

The connection between the three-phase power input line and the MCE-110/C and MCE-150/C must be completed using a 4-wire cable (3 phases + ground). The input terminals are marked with LINE RST and an arrow entering the terminals; see Figure 3

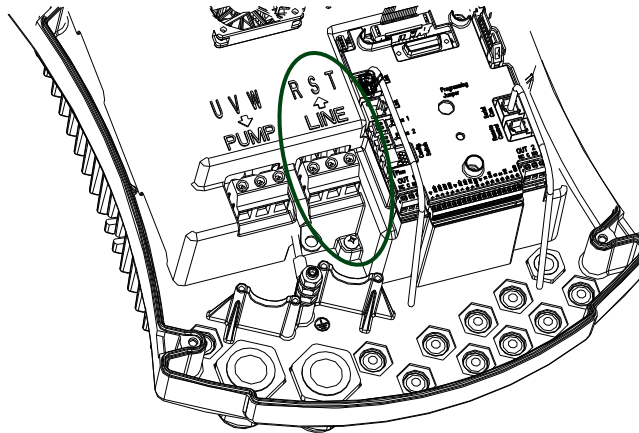
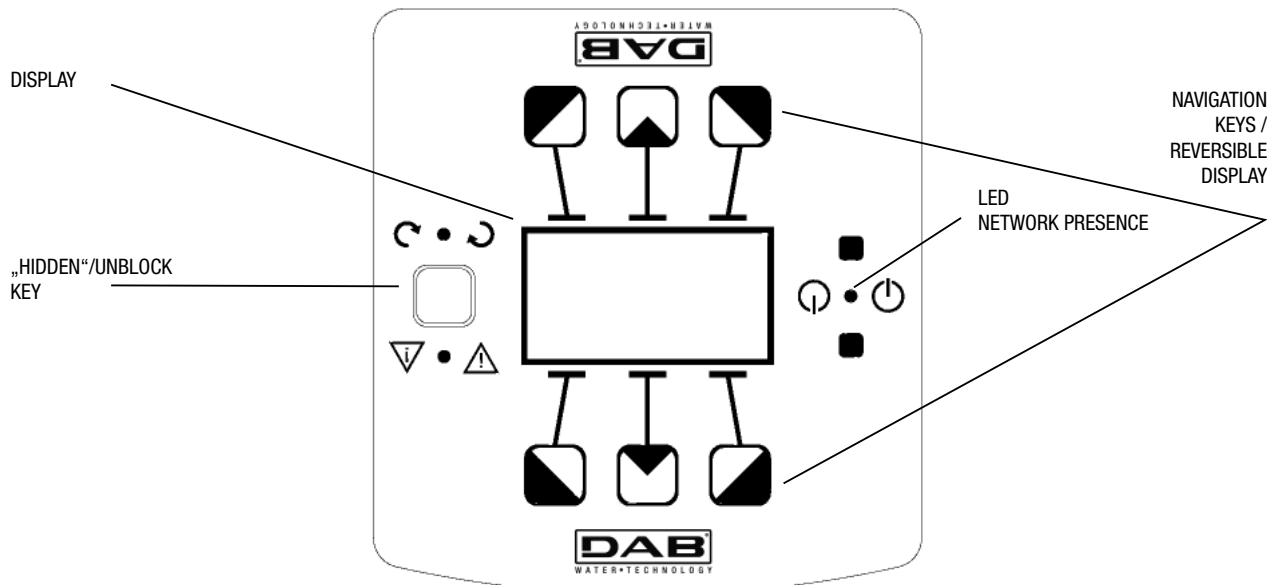

Figure 3: Electric Connections

The minimum section of the input and output cables is 6 mm² to ensure correct tightening of the cable glands, while the maximum section accepted by the terminals is 16 mm².

The MCE-110/C and MCE-150/C power input current can be generally assessed (with a safety margin) as 1/8 more than the current absorbed by the pump. Although the MCE-110/C and MCE-150/C are already fitted with internal protections, it is recommended that a protection thermal magnetic circuit breaker of appropriate size is also installed.

7 - Description of the control panel



8 - MCE/C MENU CONFIGURATIONS

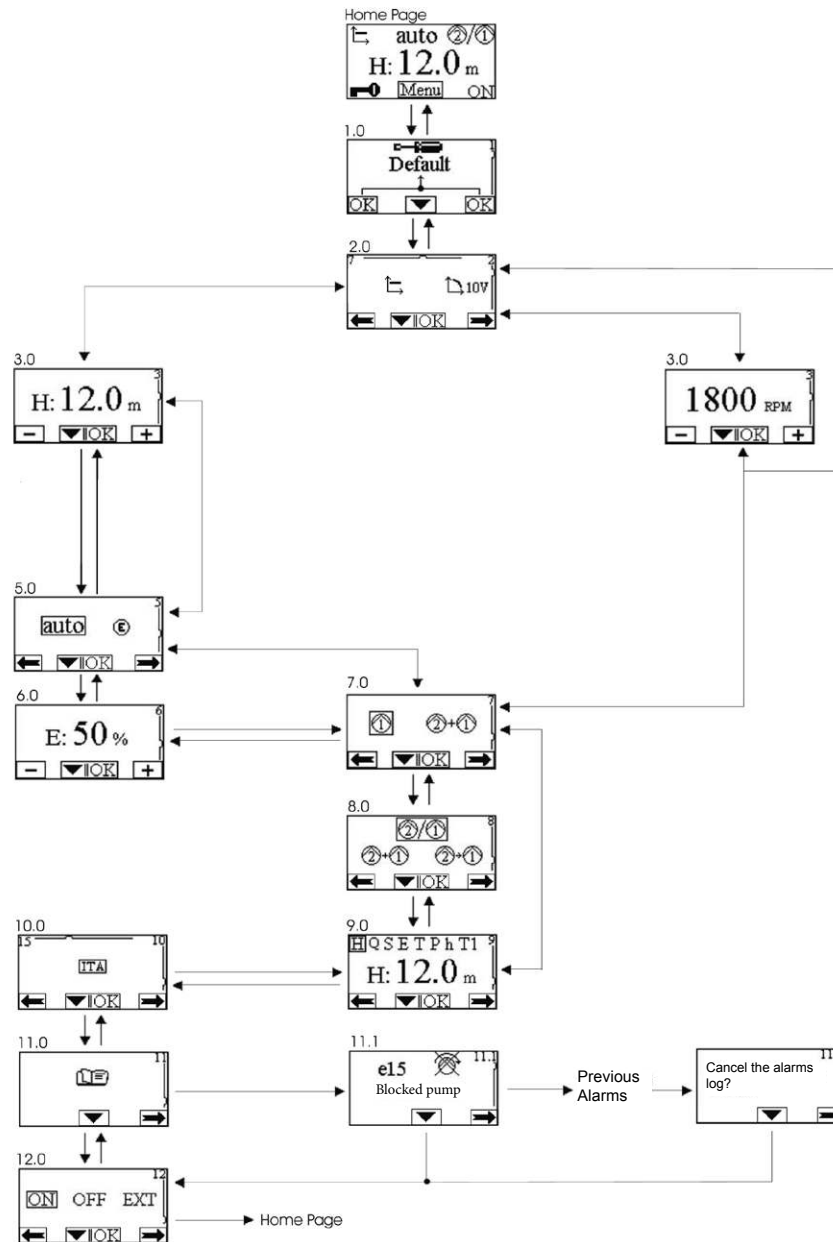

The settings are completed by passing from one page to the next in the configuration menu of the circulator.







DESCRIPTION OF DISPLAYED MEASUREMENTS

Symbol	Description
H S E P h	Parameter display
H	Head in metres
S	Speed in revolutions/minute (rpm)
E	0-10 V analogue input
P	Power in kW
h	Hours of operation

TYPES OF REGULATIONS

Symbol	Description
	Δp -c regulation (constant pressure)
	Servomotor regulation with speed set on the display.
	Servomotor regulation with speed set by remote 0-10 V signal

CIRCULATOR STATUS

Symbol	Description
	Single circulator or circulator no. 1
	Circulator no. 2
	Alternate twin circulators
	Main/backup twin circulators (switch every 24 hours)
	Simultaneous twin circulators
ON	Circulator on
OFF	Circulator off
EXT	Circulator controlled by remote signal (ref. terminals 1-2)











OPERATING MODE

Symbol	Description
auto	Auto mode
	Economy mode

9 - Factory settings

Parameter	Value
Mode of regulation	Parameter display
Hs (Differential Pressure Set-point)	50 % of the maximum pump head (see the sensitive inverter parameters set by the factory)
Fs (Frequency Set-point)	90 % of the nominal frequency of the pump
Operating modes	auto
Set-point reduction percentage	50 %
Twin operating modes	 = Alternate every 24 hours
Pump start command	EXT (from remote signal on input I1)

10 - Types of alarms and resolution)

Alarm Code	Alarm Symbol	Alarm Description
e0 - e16; e21		Internal Error
e17 - e19		Short Circuit
e20		Voltage Error
e22 - e30		Voltage Error
e31		Protocol Error
e32 - e35		Overtemperature
e37		Low voltage
e38		High voltage
e39 - e40		Current overload
e43; e44; e45; e54		Pressure Sensor
e46		Pump Disconnected

ERROR AND RESET CONDITIONS

Error condition		
Display indication	Description	Reset
E0 - E16	Internal error	<ul style="list-style-type: none"> - Remove voltage to the MCE - Wait 5 minutes and then reconnect the MCE. - If the error persists, replace the MCE.
E37	Low network voltage (LP)	<p>Remove voltage to the MCE</p> <ul style="list-style-type: none"> - Wait 5 minutes and then reconnect the MCE. - Check that the network voltage is correct. If necessary reset it to the plate details.
E38	High network voltage (HP)	<ul style="list-style-type: none"> - Remove voltage to the MCE - Wait 5 minutes and then reconnect the MCE. - Check that the network voltage is correct. If necessary reset it to the plate details.
E32-E35	Critical overheating of electronic parts	<ul style="list-style-type: none"> - Remove voltage to the MCE - After waiting 5 minutes, remove the MCE from the pump and clean the cover of the motor. - Clean the dissipator.
E43-E45; E54	No sensor signal	<ul style="list-style-type: none"> - Check the connection of the sensor. - Replace the sensor, if faulty.
E39-E40	Current overload protection	<ul style="list-style-type: none"> - Check that the circulator is turning freely. - Check that the antifreeze added does not exceed the maximum amount of 30 %.
E21-E30	Voltage Error	<ul style="list-style-type: none"> - Remove voltage to the MCE. - Wait 5 minutes and then reconnect the MCE. - Check that the network voltage is correct. If necessary reset it to the plate details.
E31	Twin communication not found	<ul style="list-style-type: none"> - Check that the communication cable is not damaged. - Check that both circulators can be powered.

ENERGY SAVING

Reducing, even for just one minute, the rotation speed of a motor, can bring significant energy savings, as the power consumed by an electric motor is proportional to the cube of the number of revolutions.

For example, a pump connected to the power network working at approximately 2950 rpm, if set to operate at 40 Hz, will turn at a speed approximately 20 % lower (approximately 2360 rpm). This will give a 40 % saving on the absorbed power. The reduction in rotation speed of the motor consistently increases the life of the pump, due to the less stress it is subjected to.

Variation in pump performance in relation to speed variation

The number of "n" pump revolutions has a significant impact on the performance of the pump itself.

The variation of the flow is proportional to the variation in the number of revolutions.

The pressure variation follows a quadratic law in relation to the variation of the number of revolutions.

The power follows a cubic law in relation to the variation of the number of revolutions.

A small variation in the number of revolutions translates into an important variation of the power, with corresponding energy savings.

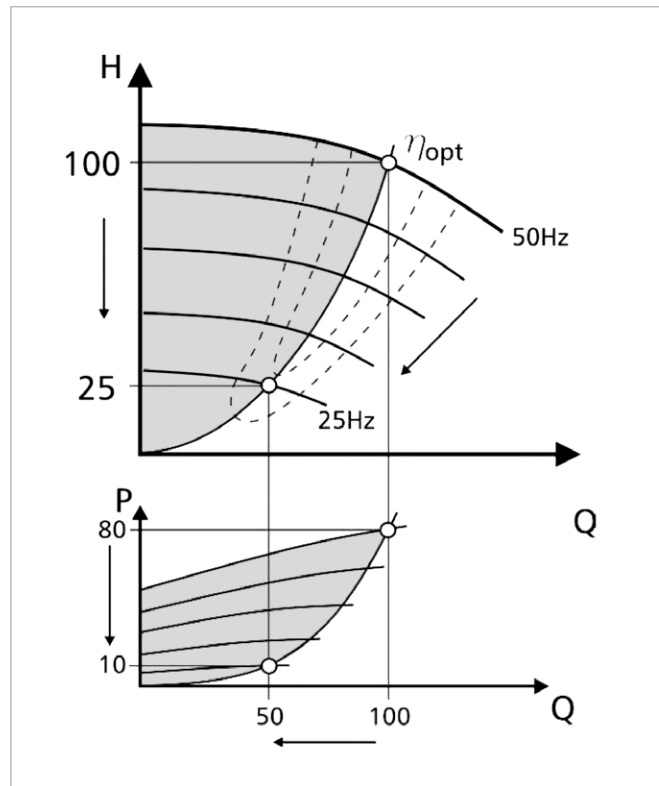

PERFORMANCE CURVES WITHOUT INVERTER

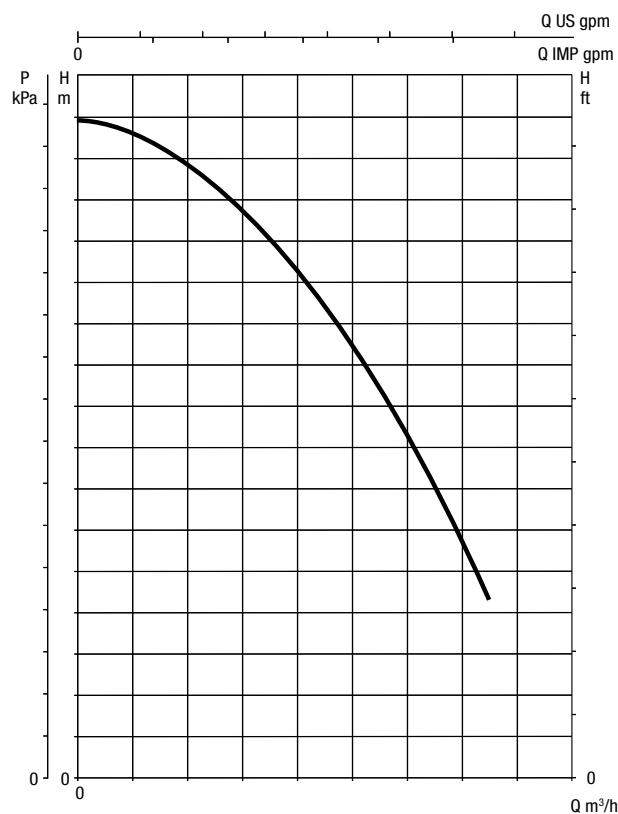

PERFORMANCE CURVES WITH INVERTER

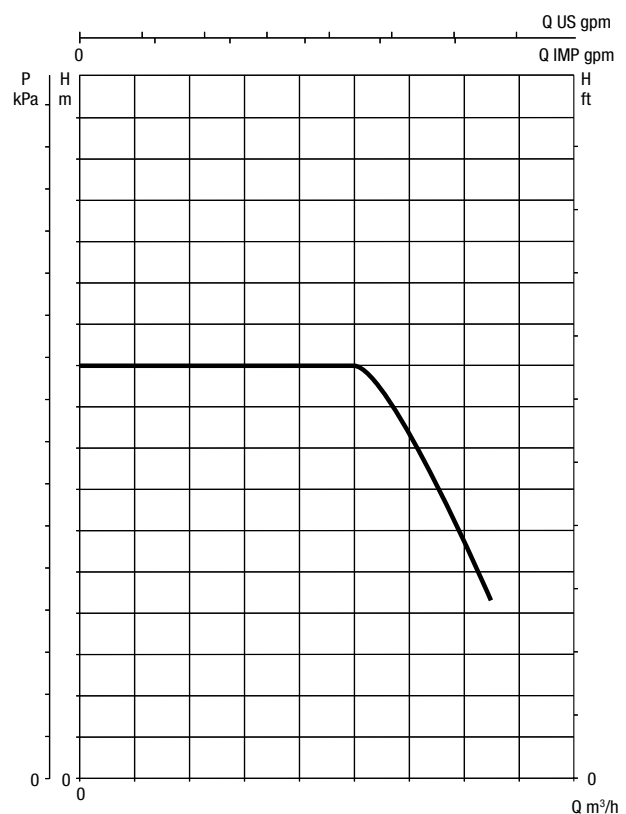

MAIN FUNCTIONS DISPLAYED ON THE MCE/P

Pump operating frequency (Hz)
 Instantaneous pressure (bar)
 Pump status (SB = idle, GO = operation)
 Pump priority identification [1],[2],[3]...

POSSIBLE INPUT-OUTPUT ELECTRIC CONNECTIONS

MCE/P systems have 4 inputs and 2 outputs (by individual MCE/P), in order to make it possible to obtain certain interface solutions with more complex installations, and remotely control some status conditions (block/operation).

By correctly connecting the digital inputs, it is possible to obtain several functions,
 block due to lack of water with settable time
 second set-point
 pump stop remote signal

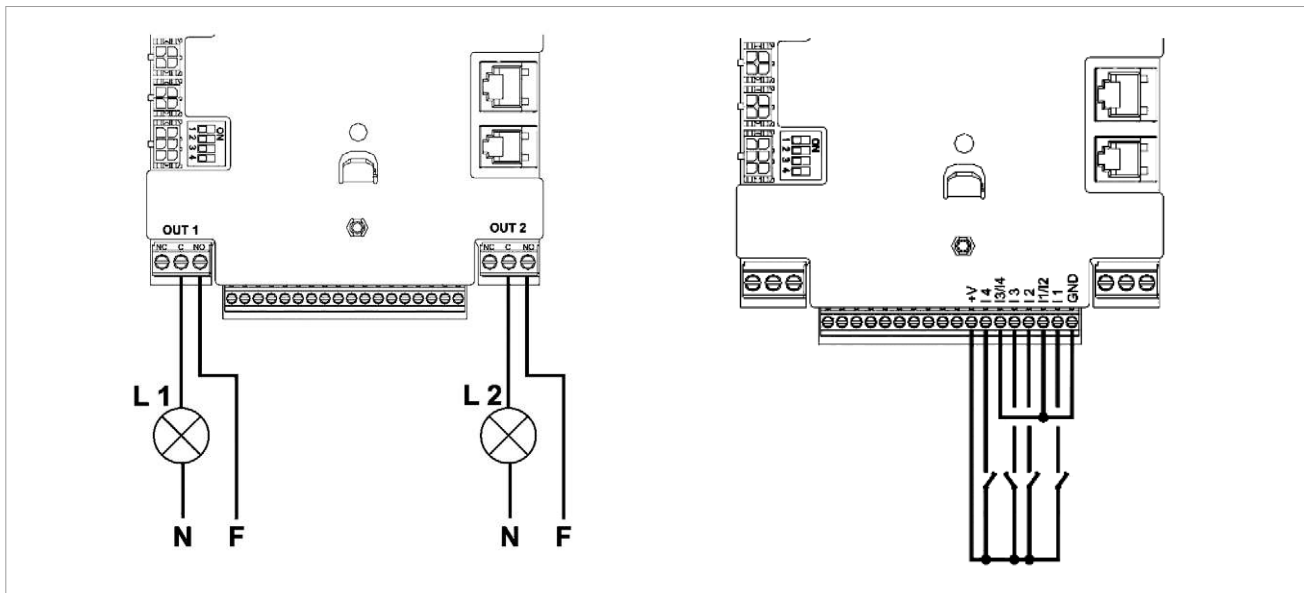

CHARACTERISTICS OF THE OPTOCOUPLED INPUT CONTACTS

The connections of the inputs listed below refer to the J5 18-pole terminal board, numbered starting from pin 1 on the left. On base terminal board is the indication of the inputs.

- I 1: Pin 16 and 17
- I 2: Pin 15 and 16
- I 3: Pin 13 and 14
- I 4: Pin 12 and 13

The switching on of the inputs is possible both in direct and in alternate current.







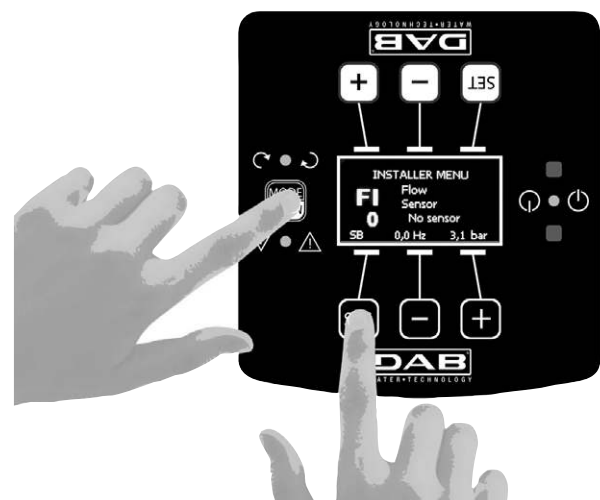













KEYPAD AND DISPLAY

USER INTERFACE

	The MODE key is used to jump to the next item of the same menu. An extended pressure of at least 1 second is used to go back to the previous item of the same menu.
	The SET key is used to exit the current menu.
	Decrease the current parameter (if it can be modified).
	Increase the current parameter (if it can be modified).



DIRECT ACCESS WITH COMBINATION OF KEYS

MENU NAME	DIRECT ACCESS KEYS	KEY PRESSURE TIME
User		Upon release of the button
Monitor	 	2 Sec
Set-point	 	2 Sec
Manual	  	5 Sec
Installer	  	5 Sec
Technical support	  	5 Sec
Factory value reset	 	2 seconds after switching the unit on
Reset	   	2 Sec

STATUS AND ERROR MESSAGE IN THE MAIN PAGE

ERROR AND STATUS CONDITIONS DISPLAYED ON THE FIRST PAGE	
IDENTIFIER	DESCRIPTION
GO	Electric pump on
SB	Electric pump idle (off)
BL	Block due to lack of water
LP	Block due to low power input voltage
HP	Block due to high internal power input voltage
EC	Block due to wrong setting of the nominal current
OC	Block due to electric pump motor current overload
OF	Block due to current overload in the output stages
SC	Block due to short circuit in the output phases
OT	Block due to overheating of the power stages
OB	Block due to overheating of the printed circuit
BP	Block due to pressure sensor fault
NC	Pump disconnected
F1	Float function Status / Alarm
F3	System disabling function Status / Alarm
F4	Low pressure signal function Status / Alarm
P1	Operating status with auxiliary pressure 1
P2	Operating status with auxiliary pressure 2
P3	Operating status with auxiliary pressure 3
P4	Operating status with auxiliary pressure 4
Com. icon with number	Operating status in multi inverter communication with the indicated address
Com. icon. With E	Multi inverter system communication error status
E1...E16	Internal error 0...16
EE	Writing and reading on Eeprom of the factory settings
Low voltage WARN	No power input voltage detected warning

TECHNICAL APPENDIX

MCE/P INVERTER

STRUCTURE OF THE MENUS

COMPACT MENU (VISIBLE)			EXPANDED MENU (DIRECT ACCESS OR PASSWORD)			
Main Menu	User Menu (mode)	Monitor Menu (set-minus)	Set-point Menu (mode-set)	Manual Menu (set-plus-minus)	Installer Menu (mode-set-minus)	Tech. Supp. Menu (mode-set-plus)
MAIN (Main Page)	FR Rotation frequency	VF -	SP Set-point pressure	FP Manual mode frequency	RC Nominal current	TB Block time for lack of water
Menu Selection	VP Pressure	TE Dissipator temperature	P1 Auxiliary pressure 1	VP Pressure	RT Rotation direction	T1 Off time after low pressure
	C1 Pump phase current	BT Card temperature	P2 Auxiliary pressure 2	C1 Pump phase current	FN Nominal frequency	T2 Off delay
	PO Power delivered to the pump	FF Log Fault & Warning	P3 Auxiliary pressure 3	PO Power delivered to the pump	OD (*) Type of system	GP Proportional gain
	SM System monitor	CT Contrast	P4 Auxiliary pressure 4	RT Rotation direction	RP Pressure decrease for restart	GI Integral gain
	VE Information HW and SW	LA Language		VF Flow display	AD Address	FS Maximum frequency
		HO Hours of operation			PR Pressure Sensor	FL Minimum frequency
					MS Measurement system	NA Active inverters
					FZ Zero flow frequency	NC Maximum simultaneous inverters
					FT Minimum flow threshold	IC Inverter config
					SO Dry run factor minimum threshold	ET Max exchange time
					MP Dry run minimum pressure	AE Antifreeze
						I1 In put 1 function
						I2 In put 2 function
						I3 In put 3 function
						I4 In put 4 function
						O1 Output 1 function
						O2 Output 2 function
						RF Fault and warning reset

(*) with or without expansion vessels

SET-POINT CONFIGURATION

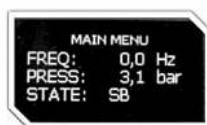

Starting from the main Menu, press MODE and SET at the same time, until the SP (set-point) parameter appears. Use the "+" and "-" keys to set the desired operating point, confirm using "SET" and return to the main menu.

Note: Main parameters set at DAB Pumps.

TROUBLESHOOTING

Fault	Possible causes	Solutions
The display shows EC	Current (RC) of the pump not set.	Set the RC parameter (see par. 6.5.1).
The display shows BL	<ol style="list-style-type: none"> 1) No water. 2) Pump not primed. 3) Flow sensor disconnected. 4) Set-point too high for the pump. 5) Inverted rotation direction. 6) Wrong pump current settings RC (*). 7) Maximum frequency too low (*). 8) Wrong SO parameter. 9) Wrong minimum pressure MP parameter. 	<ol style="list-style-type: none"> 1-2) Prime the pump and check that there is no air in the piping. Check that the suction and any filters installed are not obstructed. Check that the pump pipes at the inverter are not broken, or suffering heavy leaks. 3) Check the connections towards the flow sensor. 4) Decrease the set-point, or use a pump suitable for system needs. 5) Check the rotation direction (see par. 6.5.2). 6) Set the correct pump current RC (*) (see par. 6.5.1). 7) If possible increase the FS, or lower RC (*) (see par. 6.6.6). 8) Set the correct SO value (see par. 6.5.14). 9) Set the correct MP value (see par. 6.5.15).
The display shows BPx	<ol style="list-style-type: none"> 1) Flow sensor disconnected. 2) Pressure sensor faulty. 	<ol style="list-style-type: none"> 1) Check the connection of the pressure sensor cable. BP1 refers to the sensor connected to Press 1, BP2 to that connected to Press 2, BP3 to that connected to J5. 2) Replace the pressure sensor.
The display shows OF	<ol style="list-style-type: none"> 1) Excessive absorption. 2) Pump blocked. 3) Pump using a lot of current at start-up. 	<ol style="list-style-type: none"> 1) Check the type of connection, star or triangle. Check that the motor does not absorb a higher current than the maximum current that can be delivered by the inverter. Check that all the phases of the motor are connected. 2) Check that the impeller or the motor are not blocked or impaired by foreign bodies. Check the connection of the motor phases. 3) Decrease the AC acceleration parameter (see par. 6.6.11).
The display shows OC	<ol style="list-style-type: none"> 1) Wrong pump current set (RC). 2) Excessive absorption. 3) Pump blocked. 4) Inverted rotation direction. 	<ol style="list-style-type: none"> 1) Set RC with the current in relation to the type of connection, star or triangle, shown on the motor plate (see par. 6.5.1). 2) Check that all the phases of the motor are connected. 3) Check that the impeller or the motor are not blocked or impaired by foreign bodies. 4) Check the rotation direction (see par. 6.5.2).
The display shows LP	<ol style="list-style-type: none"> 1) Low power input voltage. 2) Excessive voltage drop on the line. 	<ol style="list-style-type: none"> 1) Check that the line voltage is correct. 2) Check the section of the power input cables (see par. 2.2.1).
Regulation pressure higher than SP.	FL set too high.	Decrease the minimum operating frequency FL (if the electric pump allows it).
The display shows SC	Short circuit between the phases.	Check that the motor is working correctly and the motor connections.
The pump does not stop.	<ol style="list-style-type: none"> 1) Minimum flow threshold FT set too low. 2) Minimum off frequency FZ set too low (*). 3) Short observation time (*). 4) Unstable pressure regulation (*). 5) Incompatible use (*). 	<ol style="list-style-type: none"> 1) Set a higher FT. 2) Set a higher FZ. 3) Wait for the self-learning procedure to complete (*), or perform a quick learning procedure (see par. 6.5.9.1.1). 4) Correct GI and GP(*) (see par. 6.6.4 and 6.6.5). 5) Check that the system meets the conditions of use without flow sensor (*) (see par. 6.5.9.1). If deemed appropriate, perform a MODE SET + - reset to recalculate the conditions without flow sensor.
Unwanted pump stops	<ol style="list-style-type: none"> 1) Short observation time (*). 2) Minimum frequency FL set too high (*). 3) Minimum off frequency FZ set too high (*). 	<ol style="list-style-type: none"> 1) Wait for the self-learning procedure to complete (*), or perform a quick learning procedure (see par. 6.5.9.1.1). 2) If possible set a lower FL (*). 3) Set a lower FZ.
The multi inverter system does not start.	The RC current has not been set on one or more inverters.	Check the RC current settings on each inverter.
The display shows: Press + to propagate this configuration	One or more inverters have unaligned sensitive parameters.	Press + on the inverter for which you are certain that to have the most recent and correct parameter configuration.
On a multi inverter system parameters fail to propagate.	<ol style="list-style-type: none"> 1) Different passwords. 2) Configurations that cannot be propagated present. 	<ol style="list-style-type: none"> 1) Access all the inverters individually and set the same password on all of them, or remove the password. See section 6.6.16. 2) Change the configuration so that it can be propagated. Configurations with FI=0 and FZ=0 cannot be propagated. See section 4.2.2.2.

(*) The asterisk refers to uses without flow sensor.



DNA
DNA
PUMPS SELECTOR



On-line product selection



DAB PUMPS LTD.
Unit 4 and 5, Stortford Hall Industrial Park,
Dunmow Road,
Bishops Stortford,
Herts
CM23 5GZ - UK
salesuk@dwtgroup.com
Tel. +44 1279 652 776
Fax +44 1279 657 727



DAB PUMPS IBERICA S.L.
Avenida de Castilla nr.1 Local 14
28830 - San Fernando De Henares - Madrid
Spain
info.spain@dwtgroup.com
Tel. +34 91 6569545
Fax: +34 91 6569676



DAB PUMPS INC.
3226 Benchmark Drive
Ladson, SC 29456 - USA
info.usa@dwtgroup.com
Tel. 1-843-824-6332
Toll Free 1-866-896-4DAB (4322)
Fax 1-843-797-3366



DAB PUMPS B.V.
Brusselstraat 150
B-1702 Groot-Bijgaarden - Belgium
info.belgium@dwtgroup.com
Tel. +32 2 4668353
Fax +32 2 4669218



DAB PRODUCTION HUNGARY KFT.
H-8800
Nagykanizsa, Buda Ernő u.5
Hungary
Tel. +36 93501700



DWT SOUTH AFRICA
Podium at Menlyn,
3rd Floor, Unit 3001b, 43 Ingersol Road,
C/O Lois and Atterbury street,
Menlyn, Pretoria, 0181 - South-Africa
info.sa@dwtgroup.com
Tel. +27 12 361 3997
Fax +27 12 361 3137



DAB PUMPS B.V.
Albert Einsteinweg, 4
5151 DL Drunen - Nederland
info.netherlands@dwtgroup.com
Tel. +31 416 387280
Fax +31 416 387299



DAB PUMPS POLAND Sp. z o.o.
Mokotów Marynarska
ul. Postępu 15C
02-676 Warszawa - Poland
polska@dabpumps.com.pl
Tel. +48 223 816 085



DAB PUMPS CHINA
No.40 Kaifuo Road, Qingdao Economic & Technological
Development Zone
Qingdao City, Shandong Province - China
PC: 266500
info.china@dwtgroup.com
Tel. +8653286812030-6270
Fax +8653286812210



DAB UKRAINE Representative Office
Regus Horizon Park
4 M. Hrinchenka St, suit 147
03680 Kiev - Ukraine
Tel. +38 044 391 59 43



DAB PUMPEN DEUTSCHLAND GmbH
Tackweg 11
D - 47918 Tönisvorst - Germany
info.germany@dwtgroup.com
Tel. +49 2151 82136-0
Fax +49 2151 82136-36



OOO DAB PUMPS
Novgorodskaya str. 1, block G
office 308, 127247, Moscow - Russia
info.russia@dwtgroup.com
Tel. +7 495 122 0035
Fax +7 495 122 0036



DAB PUMPS DE MÉXICO, S.A. DE C.V.
Av Gral Álvaro Obregón 270, oficina 355
Hipódromo, Cuauhtémoc 06100
México, D.F.
Tel. +52 55 6719 0493