



APPLICATIONS

The MCE/P family represents the new frontier of Dab inverters. These inverters are intended for complex professional applications. They can pilot three-phase pumps up to 15 kW. They combine the simplicity of the MCE/P series with the strength and power of the inverter. They must be fitted on the pump, and must be equipped with pressure sensors, and as optional with flow sensors. The latter guarantees improved pressure control. These models also permit the assembly of pressurisation units.

The MCE/P family combines comfort and savings, includes all the protection features, and is easy to install and configure.

WHY SHOULD I CHOOSE A DAB INVERTER?

The MCE/P inverters have the characteristics of being air cooled. They are extremely strong on-pump inverters, with a metal body and suitable for demanding applications. In order to operate, they require a pressure sensor. A flow sensor can also be installed as optional. MCE/P inverters combine comfort, with ease of installation and maintenance.

MCE/P inverters ensure maximum comfort and increase the average life of the system, also providing significant energy savings.

ADVANTAGES

- Easy to install in existing systems.
- Constant pressure.
- Up to 60% reduction in energy consumption.
- Built-in protections.
- Suitable for all pumps, with the exception of submerged pumps.
- Strong.
- Possibility of sets with interchange of up to 8 pumps.
- IP 55 protection class.

MODEL	MAXIMUM PUMP MECHANICAL POWER (P2) KW	MAX MOTOR NOMINAL CURRENT A	MIN MOTOR NOMINAL CURRENT A	POWER INPUT 50 Hz	ELECTRIC PUMP POWER INPUT	MOTOR SIZES (MEC)
MCE/P 11	1,1	6,5	1,0	Single-phase 1x230	Three-phase 3x230	71 80
MCE/P 15	1,5	8,0	1,0	Single-phase 1x230	Three-phase 3x230	90
MCE/P 22	2,2	10,5	1,0	Single-phase 1x230	Three-phase 3x230	90 100
MCE/P 30	3	7,5	2,0	Three-phase 3x400	Three-phase 3x400	100
MCE/P 55	5,5	13,5	2,0	Three-phase 3x400	Three-phase 3x400	112 132
MCE/P 110	11,0	24	2,0	Three-phase 3x400	Three-phase 3x400	132 160
MCE/P 150	15,0	32	2,0	Three-phase 3x400	Three-phase 3x400	160

SIZES AND WEIGHTS

MCE/P 11 - 15 - 22

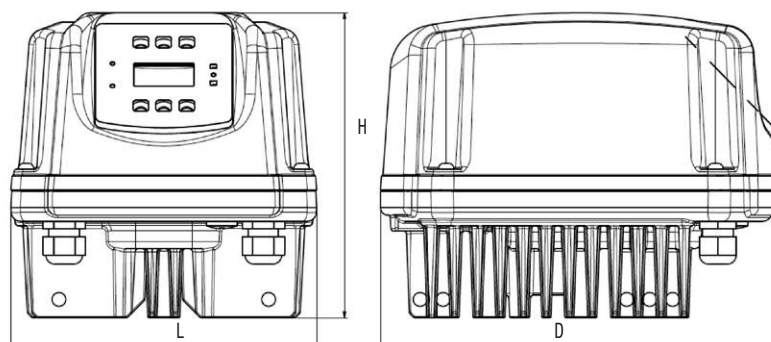

MCE/P 30 - 55

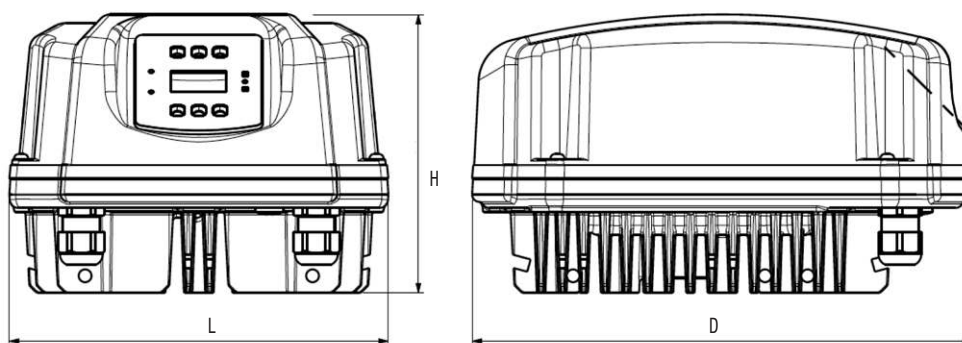

MCE/P 110 - 150

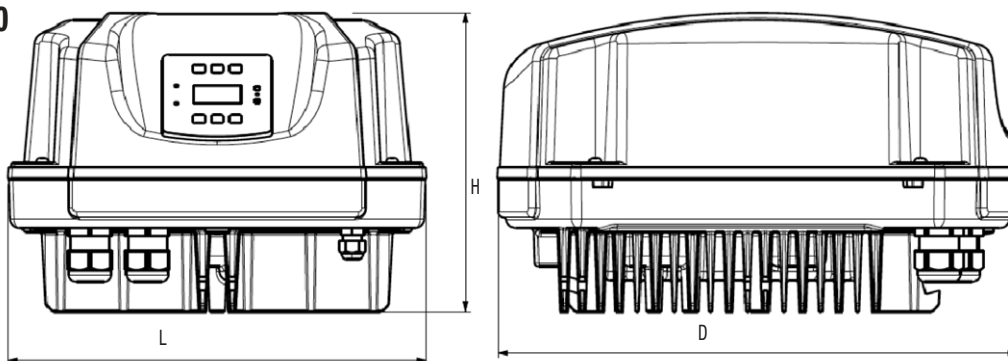

MODEL	L	H	D	PACKING DIMENSIONS			WEIGHT kg
				L/D	L/L	H	
MCE/P 11	200	199	262	265	235	215	5
MCE/P 15	200	199	262	265	235	215	5
MCE/P 22	200	199	262	265	235	215	5
MCE/P 30	267	196	352	360	280	200	7,6
MCE/P 55	267	196	352	360	280	200	7,6
MCE/P 110	343	244	425	435	345	265	12
MCE/P 150	343	244	425	435	345	265	12

NOTES ON THE MCE/P

The MCE/P family represents the new frontier of DAB inverters. MCE/P inverters are intended for complex professional applications. They can drive three phase electric pumps of up to 15 kW. They combine the simplicity of the MCE/P series with the strength and power of the inverter. They are installed on the pump itself, taking advantage of the motor cooling system. The MCE/P family combines comfort and savings, includes all the protection features, and is easy to install and configure.

ENERGY SAVING

Reducing, even for just one minute, the rotation speed of a motor, can bring significant energy savings, as the power consumed by an electric motor is proportional to the cube of the number of revolutions.

For example, a pump connected to the power network working at approximately 2950 rpm, if set to operate at 40 Hz, will turn at a speed approximately 20 % lower (approximately 2360 rpm). This will give a 40 % saving on the absorbed power. The reduction in rotation speed of the motor consistently increases the life of the pump, due to the less stress it is subjected to.

Variation in pump performance in relation to speed variation

The number of "n" pump revolutions has a significant impact on the performance of the pump itself.

- The variation of the flow is proportional to the variation in the number of revolutions.
- The pressure variation follows a quadratic law in relation to the variation of the number of revolutions.
- The power follows a cubic law in relation to the variation of the number of revolutions.
- A small variation in the number of revolutions translates into an important variation of the power, with corresponding energy savings.

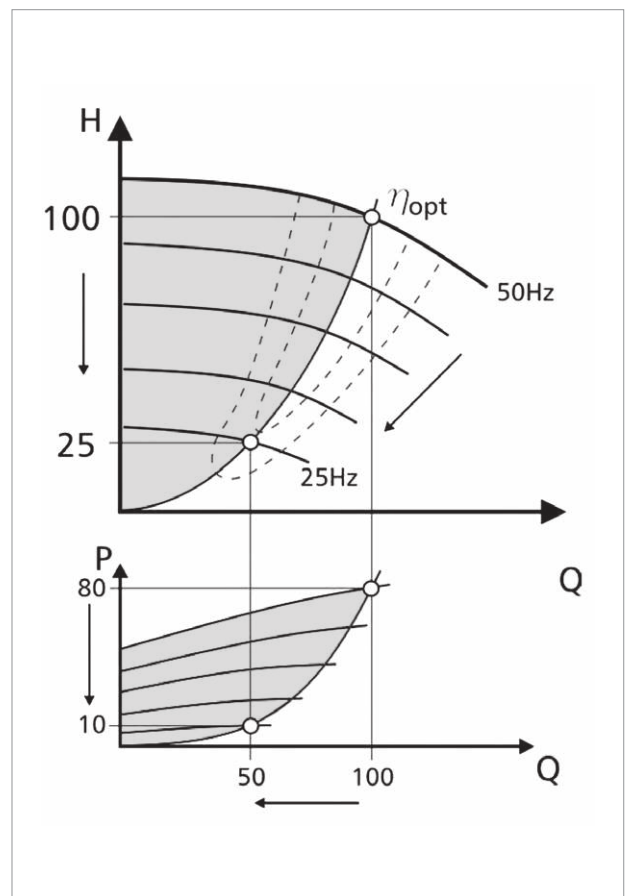

PERFORMANCE CURVES WITHOUT INVERTER



PERFORMANCE CURVES WITH INVERTER

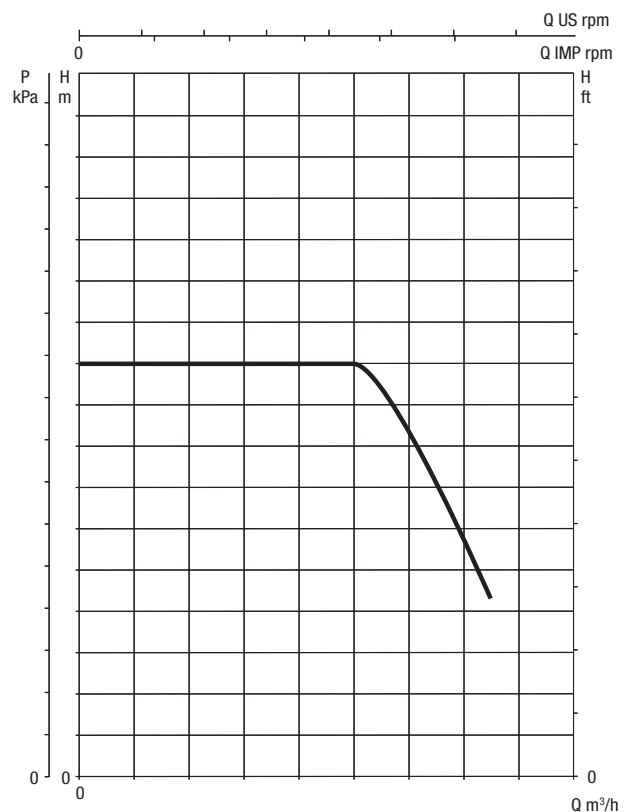

MOTOR CONNECTIONS

1 HYDRAULIC DIAGRAM

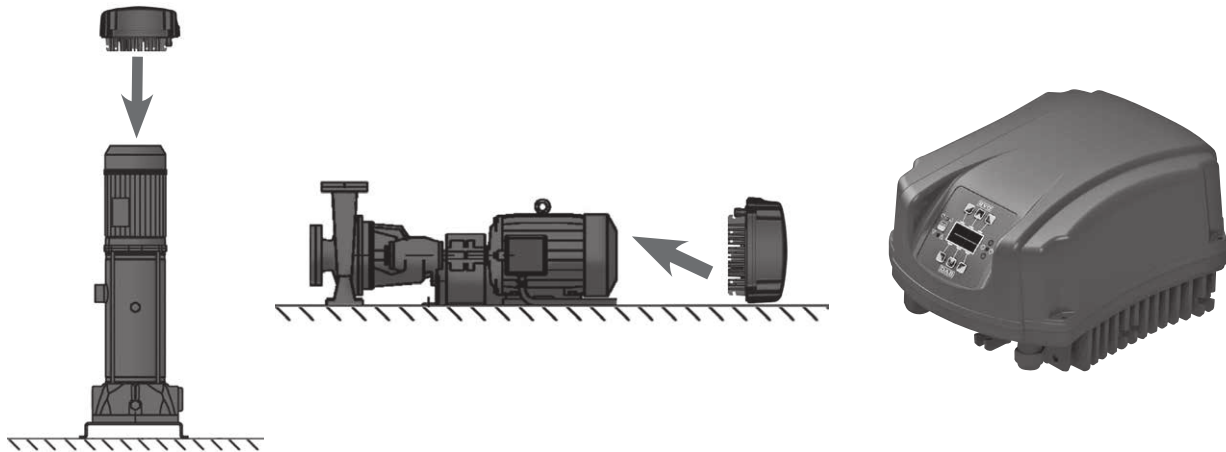

The MCE must be installed on the bottom of the motor.
 The inverter can operate both in the horizontal and the vertical position.
 2 different kits for assembly on the motor are available:

TIE RODS

They are attached to the MCE dissipator and the fan cover.

They require the fan cover to be well secured and capable of withstanding the weight of the inverter. This means that it must be fastened in position with bolts or screws.

FAN COVER KIT:

The fan cover kit must be used in all those cases when the fan cover is not well secure and sufficiently strong to withstand the weight of the inverter.

TWIN OPERATION

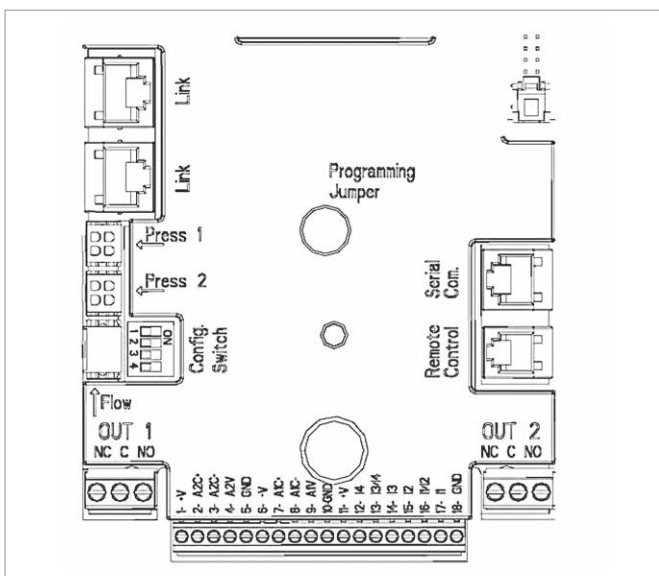

It is possible to create pumping groups with a maximum of 8 pumps. In order to do this, it is necessary to hydraulically connect the pumps on the same delivery and suction manifolds. For twin circulators, this operation is of course not necessary.

It is also necessary to connect the 2 MCE/P inverters using the appropriate interconnection cable, connected to both inverters, using one of the 2 connectors marked with Link.

For correct operation of the twin system, it is necessary that all the input terminal board external connections are connected in parallel between the 2 MCE/P, complying with the numerations of the individual terminals.