

GENIX

AUTOMATIC LIFTING STATIONS



GENIX



GENIX WL



TECHNICAL DATA

Liquid temperature range:

From 0° to +50°C.

Liquid pumped:

Sewage water containing fecal matter as regulated by EN 12050-3.

Third parts certifications: VDE-GS, LGA, VDE-EMC.

Tank capacity and delivery: approved for flush volumes of 6 and 9 liters as regulated by EN 12050-3.

International Protection grade: IP44.

APPLICATIONS

Its use is needful whenever the wastewater coming from the WC, the shower, the washbasin or the bidet cannot be expelled by gravity. GENIX models normally have a front WC connection. The difference in the GENIX WL is the side WC connection, specifically designed for WC wall-mounted installations or where there is no room enough behind the WC. In the model 130, beside the WC, three more lines can be connected, such as shower, washbasin, bidet or bathtub. The models offered stand out for silent running, even more improved in the Comfort version. The pump, powerful and reliable, and the grinding system, with blades in nickel plated stainless steel, make together a long lasting and basically daily maintenance-free product. Extremely easy the maintenance in case of clog or motor blocking, with the possibility to dismount the motor subassembly only operating on two screws, and with the unique discharge tap that will allow a clean, and free of problems, maintenance. In case of blockage, the motor unit can be accessed from the outside, with no need to remove the product. Extraordinary maintenance will be extremely easy, clean and without issues. The installation kit comes with easy-connect fittings adaptable to various pipe sections and including built-in non-return valves

Available, as accessories, an acoustic alarm anti-flooding and an adaptor pipe, to adapt the GENIX to a vast majority of existing installations.

CONSTRUCTIONAL CHARACTERISTICS

Tank in Barium 15% polypropylene. In the Comfort version, soundproof shield in Barium 70% polypropylene. Impeller in PPO 30% GF. Motor shaft in stainless steel. Grinding blades in nickel plated stainless steel.

MOTOR CONSTRUCTIONAL CHARACTERISTICS

Asynchronous motor in stainless steel.

Shaft and motor sleeve in stainless steel.

Thermal protection for overheating. Motor shaft wear resistant.

MATERIALS

N°	DESCRIPTION	MATERIALS	
1	TANK	PP 15% BARIUM	
2	SOUNDPROOF SHIELD	PP 70% BARIUM	
3	PIPE	EPDM	
4	GENIX COMFORT FLANGE GROUP V230-50Hz	MOTOR-SLEEVE	AISI 304
		MOTOR-SHAFT	AISI 416
		IMPELLER	PPO 30% FIBERGLASS
		GRINDING STATOR	AISI 304
		IMPELLER NUT	PPO 30% FIBERGLASS
		GRINDING ROTOR	AISI 420
		FLANGE	PP 30% FIBERGLASS
		PUMP BODY	PP 30% FIBERGLASS
		ALIGNING RING	PP 30% FIBERGLASS
		DIFFUSER	PP 30% FIBERGLASS
5	VALVE GROUP	NON RETURN VALVE BODY	PP 30 FIBERGLASS
		OVAL CLAPET VALVE	EPDM
		OR -3118 29.82 X 2.62	NBR
6	DELIVERY PIPE	PP 30 FIBERGLASS	

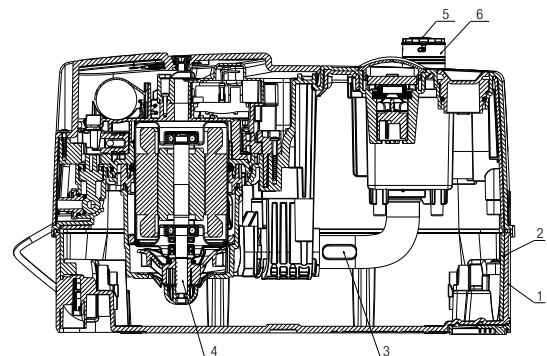

INSTALLATION INSTRUCTIONS

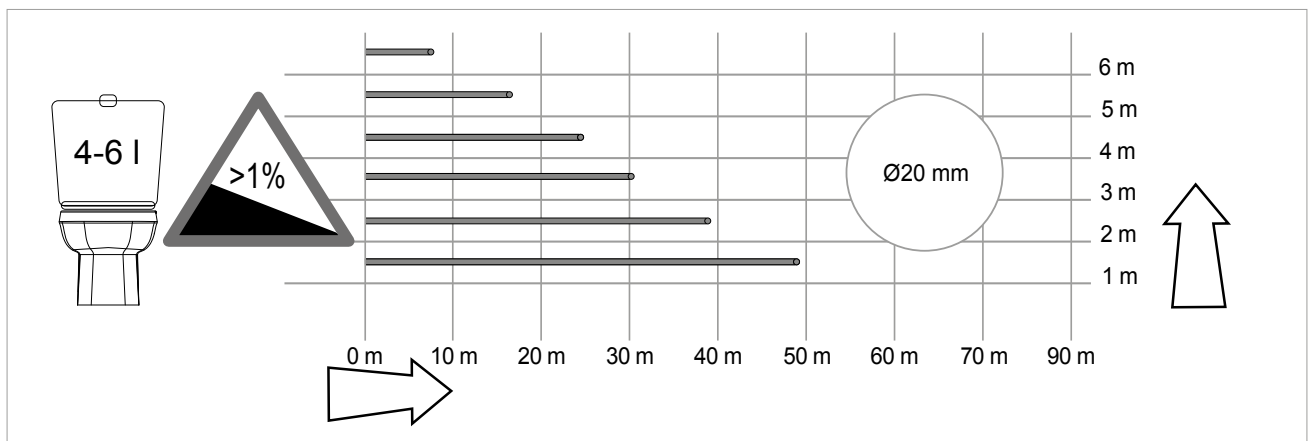
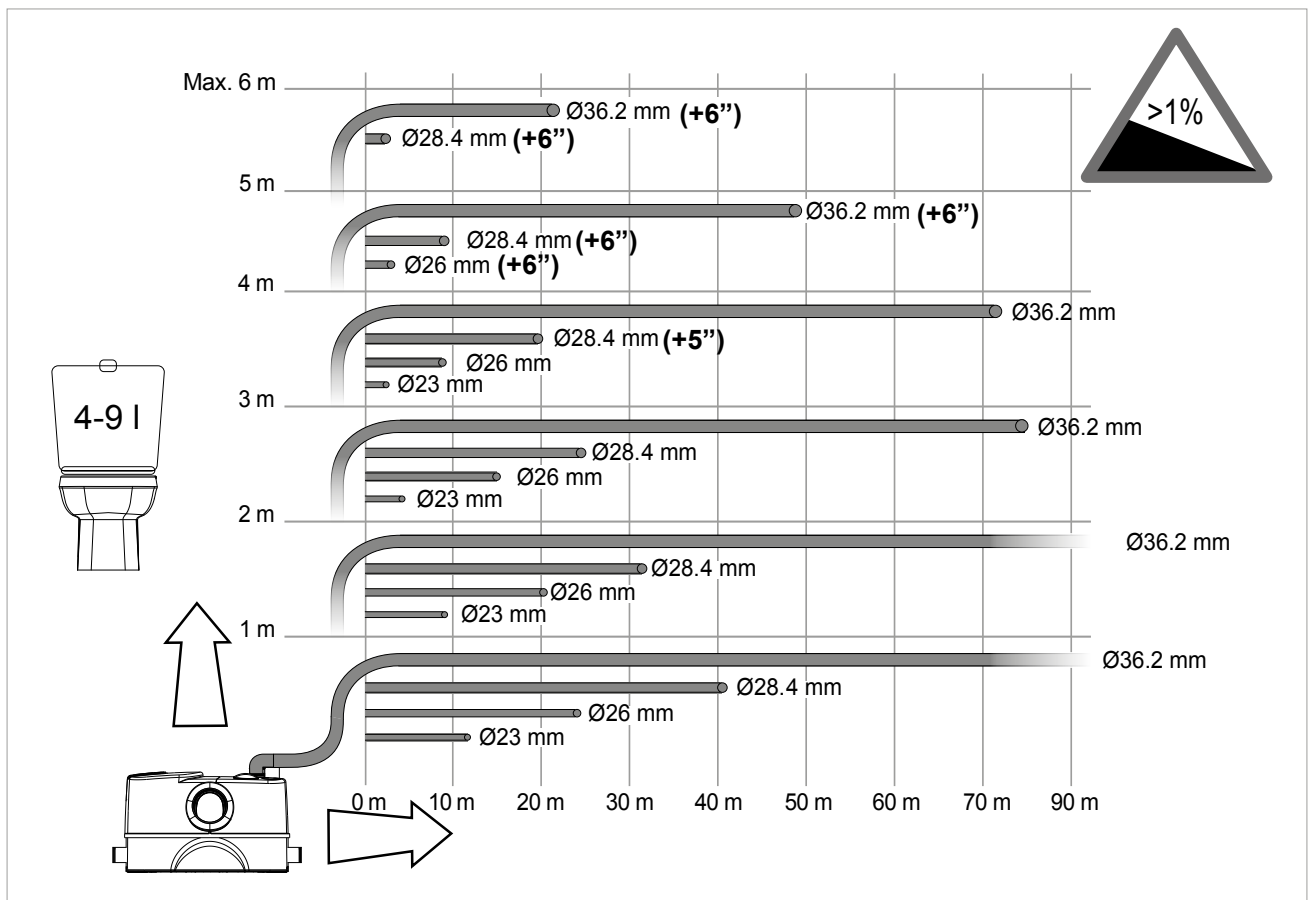
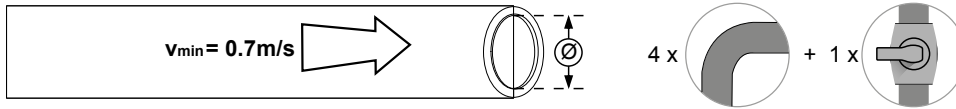
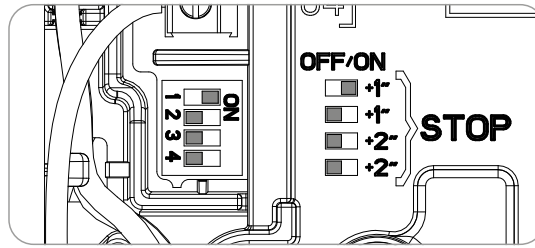

GENIX - AUTOMATIC LIFTING STATIONS

Liquid temperature range from 0° to 50°C

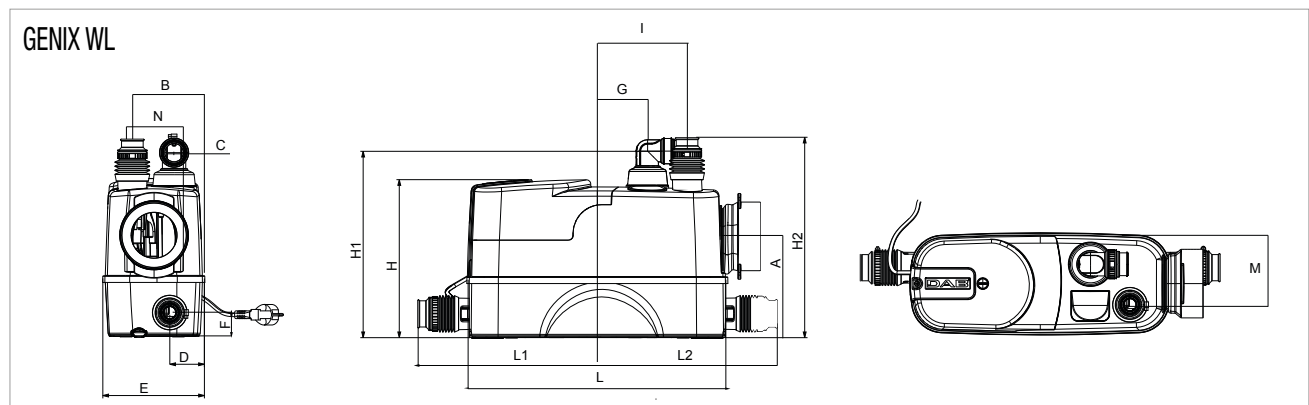
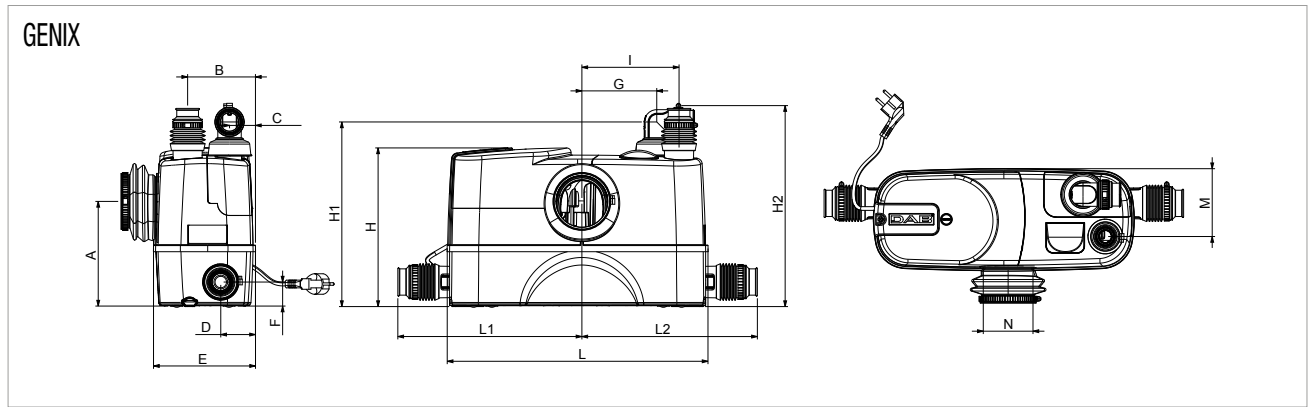

MODEL	ELECTRICAL DATA				
	VOLTAGE 50 Hz	P1 MAX kW	P2 NOMINAL		In A
			kW	HP	
GENIX 110	1 x 230 V ~	490	0,32	0,44	2,3
GENIX 130	1 x 230 V ~	490	0,32	0,44	2,3
GENIX COMFORT 110	1 x 230 V ~	490	0,32	0,44	2,3
GENIX COMFORT 130	1 x 230 V ~	490	0,32	0,44	2,3
GENIX WL 110	1 x 230 V ~	490	0,32	0,44	2,3
GENIX WL 130	1 x 230 V ~	490	0,32	0,44	2,3

MODEL	A	B	C	D	E	F	G	H	H1	H2	I	L	L1	L2	M	N	PACKING DIMENSION			VOLUME (mc)	WEIGHT Kg
																	L/A	L/B	H		
GENIX 110	183	118	45	/	178	/	178	277	323	351	170	456	/	/	118	87	538	227	426	0,0520	10,3
GENIX 130	183	118	45	60	178	42	178	277	323	351	170	456	322	307	118	87	538	227	426	0,0520	10,6
GENIX COMFORT 110	183	118	45	/	178	/	178	277	323	351	170	456	/	/	118	87	538	227	426	0,0520	11,5
GENIX COMFORT 130	183	118	45	60	178	42	178	277	323	351	170	456	322	307	118	87	538	227	426	0,0520	12
GENIX WL 110	183	125	56	/	178	/	80	277	322	346	150	456	/	/	125	87	538	227	426	0,052	10
GENIX WL 130	183	125	56	60	178	42	80	277	322	346	150	456	322	307	125	87	538	227	426	0,052	10,3

INSTALLATION

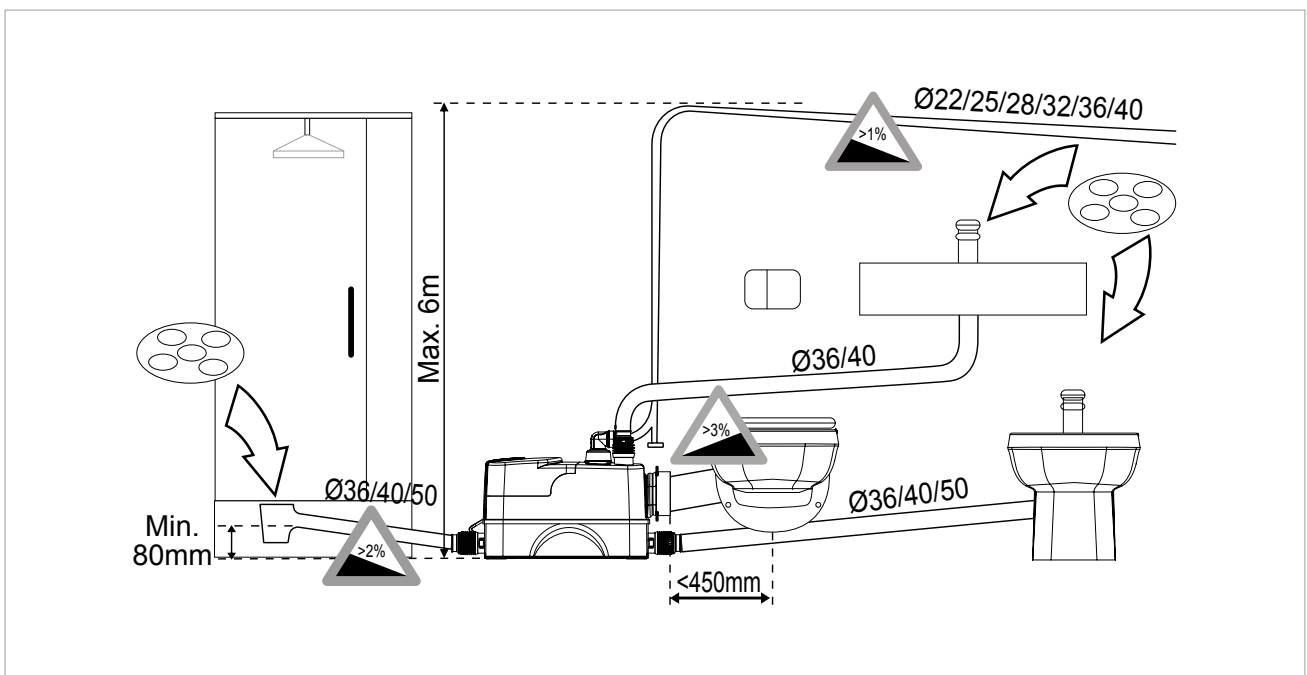
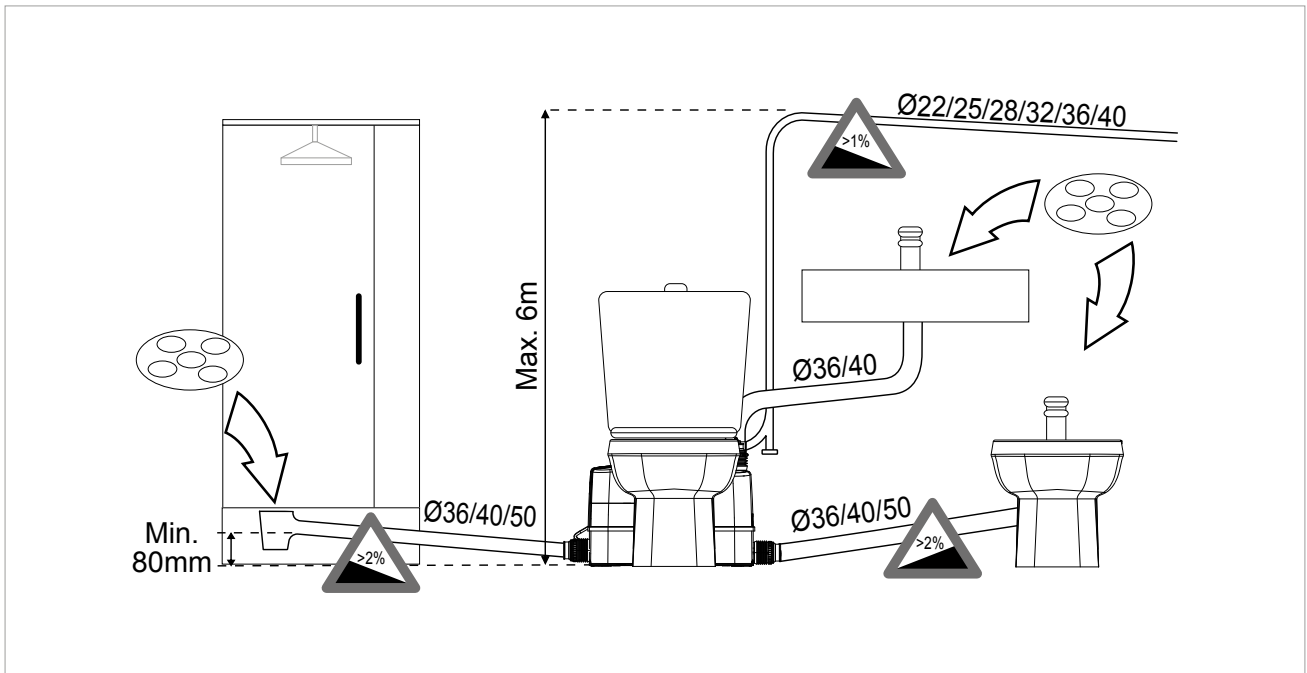



TECHNICAL DATA

Liquid temperature range:

From 0°C to +75 °C up to +90°C for 30 min.

Liquid pumped:

Sewage water containing fecal matter as regulated by EN 12050-3.

Third parts certifications: LGA

Tank capacity and delivery: 1-90 m³/h with dynamic head up to 8 metres

International Protection grade: IP44.

APPLICATIONS

Its use is needful whenever the wastewater coming from the WC, the shower, the washbasin or the bidet cannot be expelled by gravity. These lifting stations can be installed wherever there is the wish to add a toilet during new installations or constructions, renovations, or structural modifications. GENIX 110 has the facility to connect one high drain utility, like a washbasin; GENIX 130 has the facility to connect up to three utilities, even with low drain as a shower, bidet or bathtub.. Our models offer silent operation and reliable performance, thanks to a powerful motor which allows to work with temperatures up to 90 deg C. Extremely easy the maintenance in case of clog or motor blocking, with the possibility to dismount the motor subassembly only operating on two screws, and with the unique discharge tap that will allow a clean, and free of problems, maintenance. The non-return valves are integrated in the delivery pipe, and for the 130 models in the lateral bottom inlets. Available, as accessories, an acoustic alarm anti-flooding and an adaptor pipe, to adapt the GENIX to a vast majority of existing installations.

CONSTRUCTIONAL CHARACTERISTICS

30% barium-loaded polypropylene tank. 30% fibre-glass PPO impeller. Stainless steel drive shaft.

MOTOR CONSTRUCTIONAL CHARACTERISTICS

Induction type, stainless steel. Stainless steel shaft and cover.

Thermal cut-out protection.

Wear-resistant motor shaft.

MATERIALS

N°	DESCRIPTION	MATERIALS	
1	TANK	PP 15% BARIO	
2	PIPE	EPDM	
3	GENIX VT FLANGE GROUP V230-50Hz	MOTOR-SLEEVE	AISI 304
		MOTOR-SHAFT	AISI 416
		IMPELLER	PPO 30% FIBERGLASS
		IMPELLER NUT	PPO 30% FIBERGLASS
		FLANGE	PP 30% FIBERGLASS
		PUMP BODY	PP 30% FIBERGLASS
		ALIGNING RING	PP 30% FIBERGLASS
		DIFFUSER	PP 30% FIBERGLASS
4	VALVE GROUP	NON RETURN VALVE BODY	PP 30 FIBERGLASS
		OVAL CLAPET VALVE	EPDM
		OR -3118 29.82 X 2.62	NBR
5	DELIVERY PIPE	PP 30 FIBERGLASS	

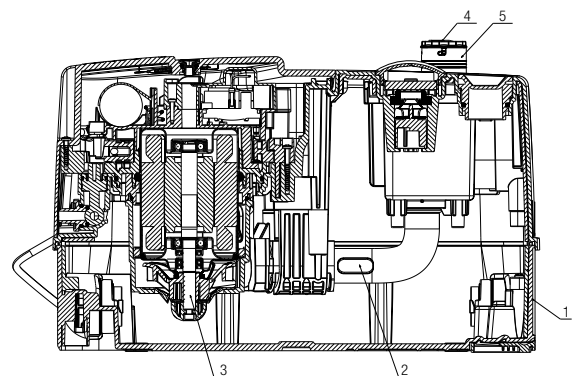

INSTALLATION INSTRUCTIONS

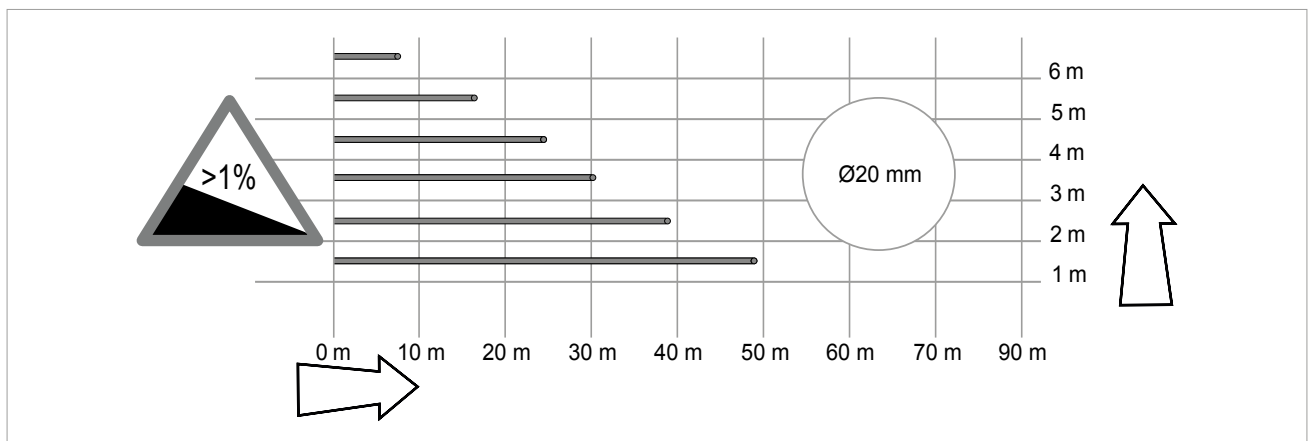
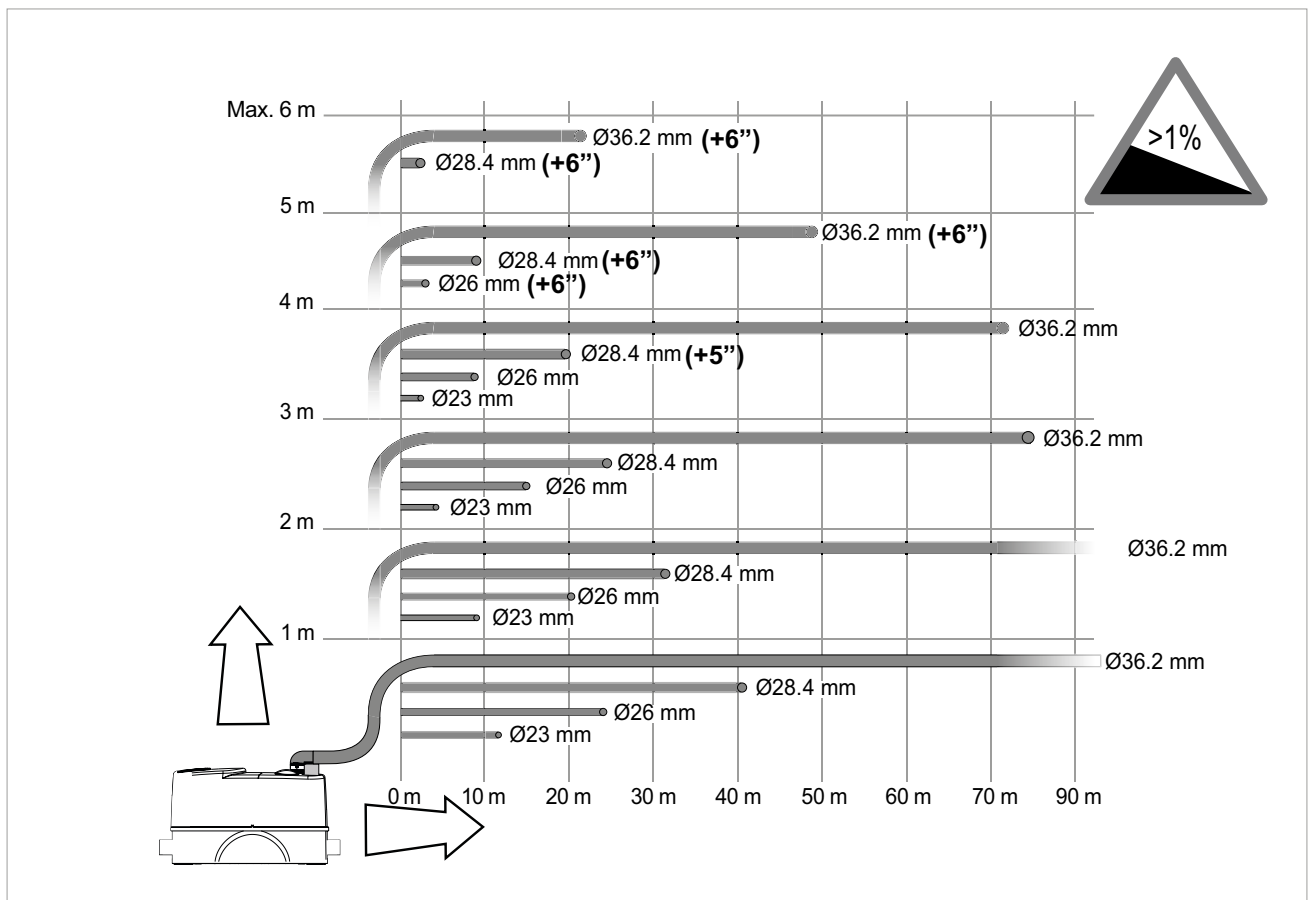
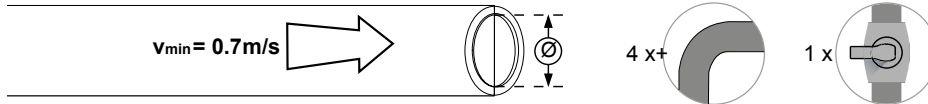
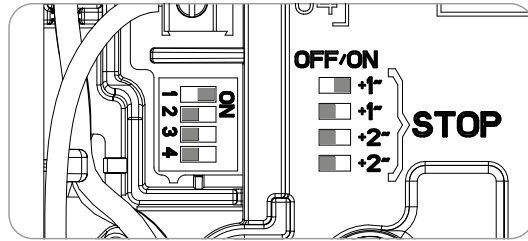

GENIX VT - AUTOMATIC LIFTING STATIONS

Liquid temperature range from 0° to +75°C

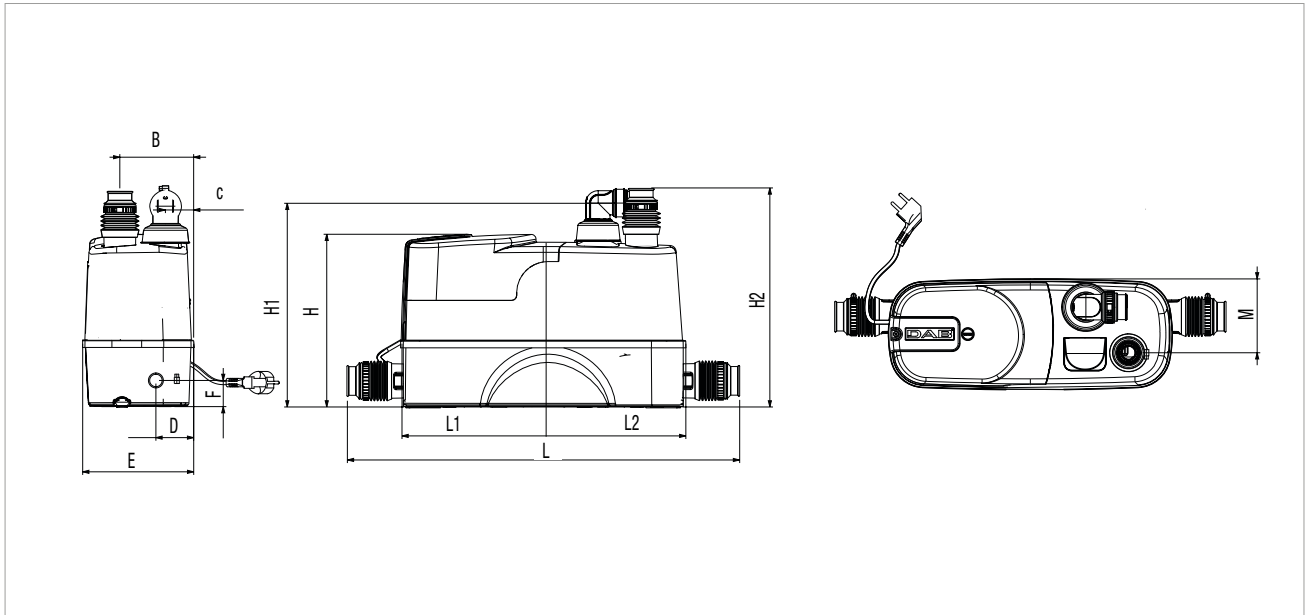

MODEL	ELECTRICAL DATA				
	VOLTAGE 50 Hz	P1 MAX kW	P2 NOMINAL		In A
			kW	HP	
GENIX VT 010	1 x 230 V ~	530 W	0,32	0,44	2,5
GENIX VT 030	1 x 230 V ~	530 W	0,32	0,44	2,5

MODEL	A	B	C	D	E	F	G	H	H1	H2	I	L	L1	L2	M	N	PACKING DIMENSION			VOLUME (mc)	WEIGHT Kg
	L/A	L/B	H																		
GENIX VT 010	183	125	56	/	178	/	80	277	322	346	150	456	/	/	125	/	538	227	426	0,052	10
GENIX VT 030	183	125	56	60	178	42	80	277	322	346	150	456	322	307	125	/	538	227	426	0,052	10,3

INSTALLATION

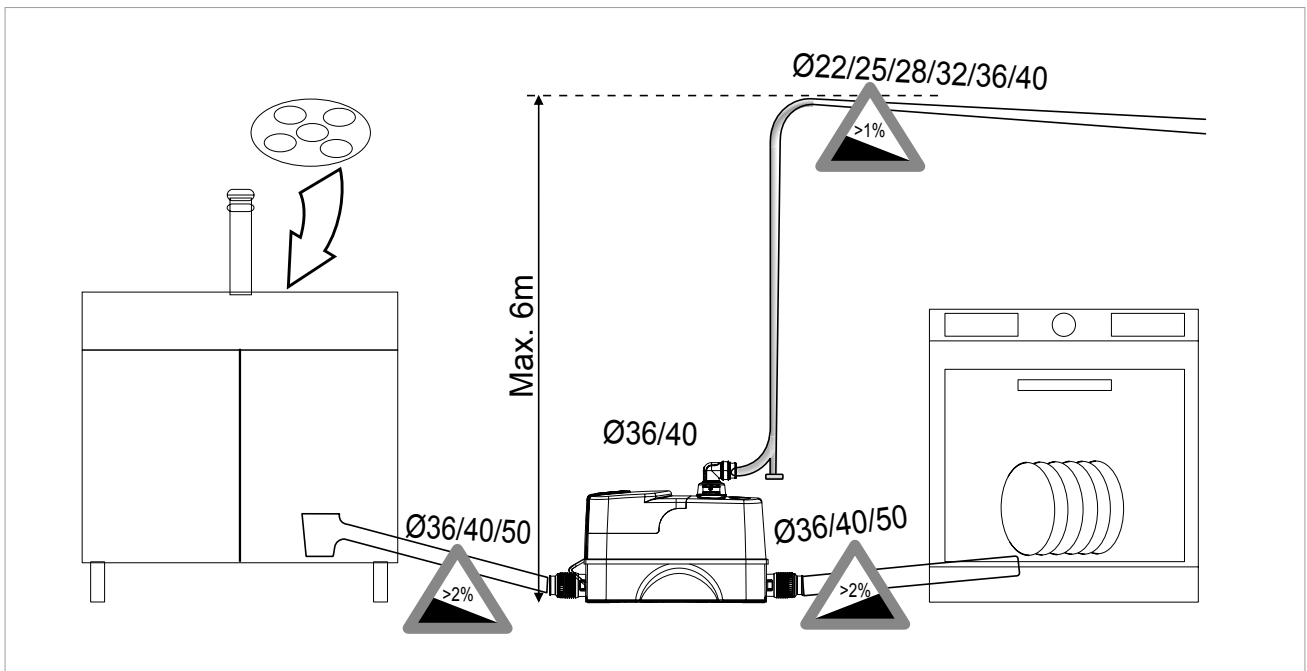
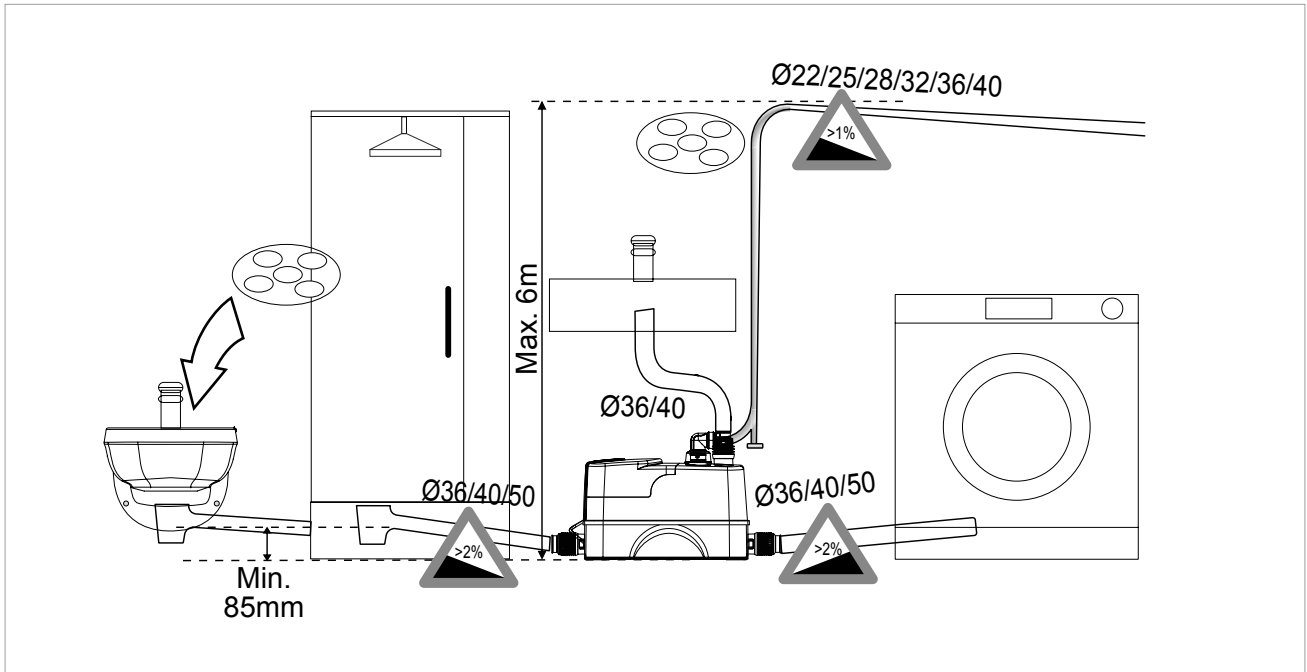

ACCESSORIES

AUTOMATIC LIFTING STATIONS

ACUSTIC ALARM	DESCRIPTION
 A black, cylindrical acoustic alarm device with a circular top and a rectangular base. It is mounted on a small circuit board with two wires extending from the bottom. The text "8 10 100 1 12V" is visible on the board.	ACUSTIC ALARM

HOSE ADAPTOR	DESCRIPTION
 A white, cylindrical hose adaptor with a flared end on one side and a standard hose connection on the other.	HOSE ADAPTOR

DNA[®]

PUMPS SELECTOR



On-line product selection



DAB PUMPS LTD.

6 Gilberd Court
Newcomen Way
Severalls Business Park
Colchester
Essex
CO4 9WN - UK
salesuk@dwtgroup.com
Tel. +44 0333 777 5010



DAB PUMPS IBERICA S.L.

Calle Verano 18-20-22
28850 - Torrejón de Ardoz - Madrid
Spain
Info.spain@dwtgroup.com
Tel. +34 91 6569545
Fax: + 34 91 6569676



DAB PUMPS SOUTH AFRICA

Twenty One industrial Estate,
16 Purlin Street, Unit B, Warehouse 4
Olifantsfontein -1666 - South Africa
info.sa@dwtgroup.com
Tel. +27 12 361 3997



DAB PUMPS BV

"Hofveld 6 C1
1702 Groot Bijgaarden - Belgium
info.belgium@dwtgroup.com
Tel. +32 2 4668353



DAB PUMPS HUNGARY KFT.

H-8800
Nagykanizsa, Buda Ernő u.5
Hungary
Tel. +36 93501700



DAB PUMPS (QINGDAO) CO. LTD.

No.40 Kaituo Road, Qingdao Economic & Technological
Development Zone
Qingdao City, Shandong Province - China
PC: 266500
sales.cn@dwtgroup.com
Tel. +86 400 186 8280
Fax +86 53286812210



DAB PUMPS B.V.

Albert Einsteinweg, 4
5151 DL Drunen - Nederland
info.netherlands@dwtgroup.com
Tel. +31 416 387280
Fax +31 416 387299



DAB PUMPS POLAND Sp. z o.o.

Ul. Janka Muzykanita 60
02-188 Warszawa - Poland
polska@dabpumps.com.pl



DAB PUMPS DE MÉXICO, S.A. DE C.V.

Av Amsterdam 101 Local 4
Col. Hipódromo Condesa,
Del. Cuauhtémoc CP 06170
Ciudad de México
Tel. +52 55 6719 0493



DAB PUMPEN DEUTSCHLAND GmbH

Tackweg 11
D - 47918 Tönisvorst - Germany
info.germany@dwtgroup.com
Tel. +49 2151 82136-0
Fax +49 2151 82136-36



DAB PUMPS INC.

3226 Benchmark Drive
Ladson, SC 29456 - USA
info.usa@dwtgroup.com
Tel. 1- 843-797-5002
Fax 1-843-797-3366



DAB PUMPS OCEANIA PTY LTD

426 South Gippsland Hwy,
Dandenong South VIC 3175 - Australia
info.oceania@dwtgroup.com
Tel. +61 1300 373 677