



TECHNICAL DATA

Operating range: from 1 to 19 m³/h.

Pumped liquid: clean, free of solids and abrasives, non viscous, non aggressive, non crystallised and chemically neutral, with properties similar to water.

Pumped liquid temperature range: from -10°C to +70°C.

Maximum ambient temperature: +40°C

Maximum operating pressure: PN10

Special executions on request: contact our sales network.

Protection class: IP44.

IE2 motors as standard from 0,75 kW to 5,5 kW - IE3 \geq 7,5 kW.

APPLICATIONS

Water lifting sets particularly suited for small and medium civil systems. The use of K double impeller electric pumps ensures a high power-pressure ratio, resulting in high performance and extremely quiet operation. Their main features are construction sturdiness, compact sizes, and utmost reliability. The sets are supplied as standard with tanks and with air supply connector.

CONSTRUCTION FEATURES

HYDRAULIC SECTION

2 K double impeller centrifugal electric pumps. Tropicalized galvanized sheet steel base complete with 4 rubber anti-vibration feet. Suction and delivery manifolds in tropicalized galvanized steel. 2 membrane tanks. Ball valves with unions on the suction and delivery ports of each pump. Check valves on the suction port of each pump. 2 tropicalized galvanized cast iron female plugs for closing the manifolds. 1 1/4" air supply connection at the suction of each pump. 1 pressure transmitter on the delivery manifold (pressure detection).

ELECTRICAL SECTION

Supplied in an IP 55 protection class self-extinguishing thermoplastic material box, the control panel protects the electric pumps from abnormal conditions such as: overload and overtemperature (with automatic reset), short circuit (with fuses - Plus model only), pump current surges (amperometric protection), abnormal voltage, dry run, quick starts, pressure sensor fault, or inconsistency of the external protection commands.

FRONT PANEL COMPONENTS:

General disconnecter with padlockable door lock. AUT-0-MAN operation selection pushbuttons. Alarm RESET pushbutton. Display for all models. Operation, stop, alarm notification lamps.

PANEL INTERNAL COMPONENTS:

Electronic control card with protection fuses and contactors. Power input connection terminal (single phase or three phase).

Dry run or overpressure pressure switch connection terminals (optional). Alarm notification N.O. contacts. Function selection mini dip switch (pressure transmitter or pressure switches, standard or additional tanks).

The electric control panel is ready for the connection of:

Dry run protection float or pressure switch kit (*).

Overpressure stop pressure switch kit (*).

(* available separately as optional.

The sets are supplied in a sturdy cardboard packaging on wooden pallet and installation / maintenance manual with electric diagram.

MATERIALS

N.	PARTS	MATERIALS	MODELS
1	PUMP BODY	CAST IRON 200 UNI ISO 185	
3	SUPPORT	CAST IRON 200 UNI ISO 185	
4	IMPELLER	TECHNOPOLYMER A	K 35/40; K 45/50; K 55/100
		TECHNOPOLYMER B	K 55/50; K 66/100; K 90/100
7	SHAFT WITH ROTOR	AISI 416 STAINLESS STEEL X12CRS13 UNI 6900/71	K 35/40
		AISI 303 STAINLESS STEEL X10CRNIS 1089 UNI 6900/71	K 45/50; K 55/50; K 55/100; K66/100; K 90/100
16	MECHANICAL SEAL	CARBON / CERAMIC	
28	GASKET	NBR RUBBER	K 35/40; K 45/50; K 55/50
		GUARNITAL	K 66/100; K 90/100
34	INTERMEDIATE DISC	CAST IRON 200 UNI ISO 185	K 35/40; K 45/50; K 55/50; K 66/100; K 90/100;

* In contact with the liquid

K 35/40

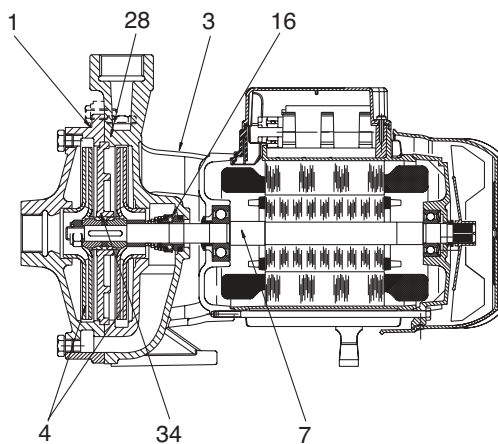

K 45/50 - K 55/50

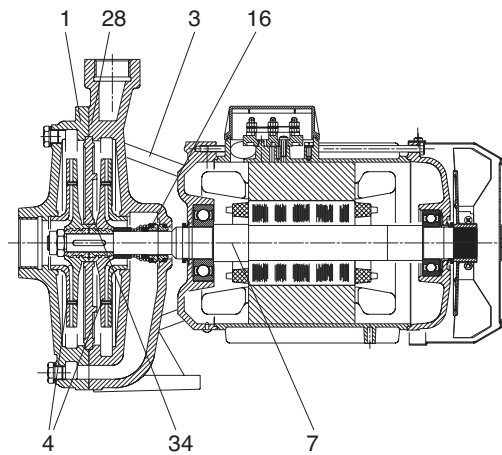

K 55/100 - K 66/100 - K 90/100

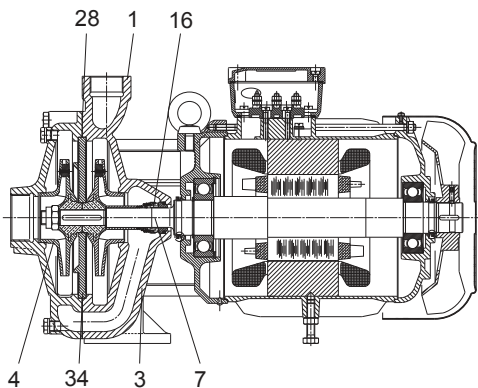

2K - CIVIL USE PRESSURE BOOSTER SETS

Pumped liquid temperature range: from -10 °C to +50 °C (K 35/40 - K 45/50 - K 55/100) / from -10 °C to +70 °C (K 55/50 - K 66/100 - K 90/100)

Maximum ambient temperature: +40 °C - Max flow rate: 19 m³/h

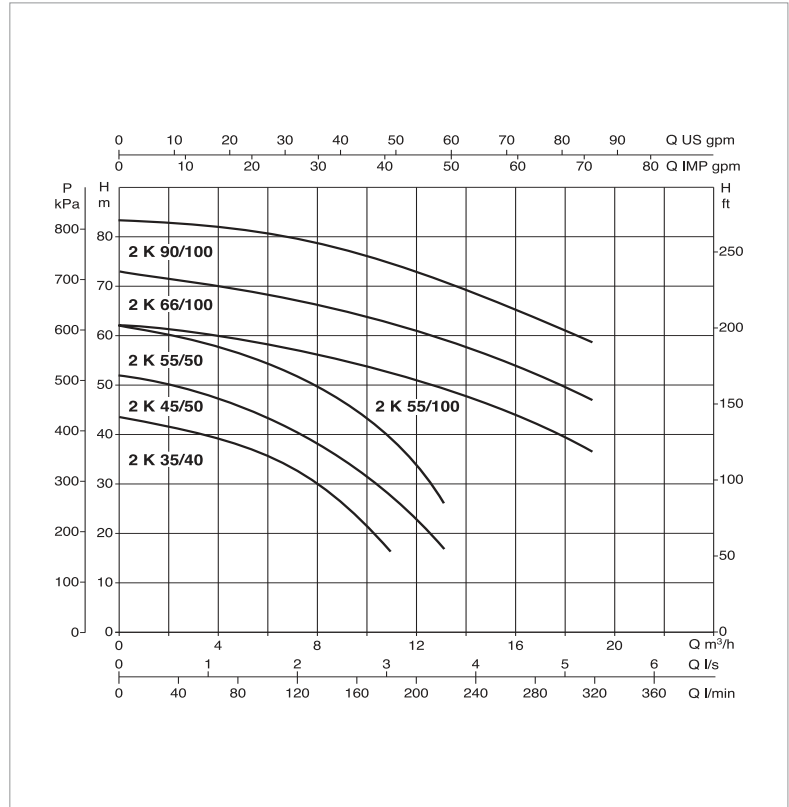
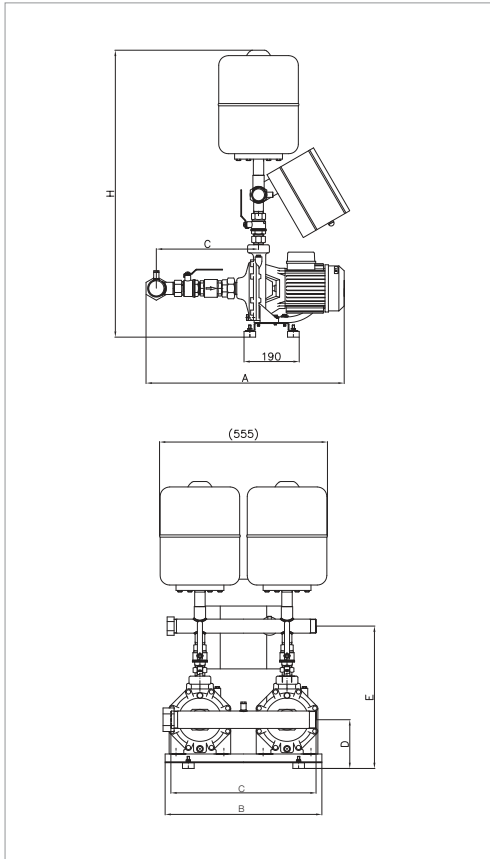

The performance curves are based on kinematic viscosity values = 1 mm²/s and density equivalent to 1000 kg/m³
Curve tolerance according to ISO 9906.

MODEL	POWER INPUT 50 Hz	P2 NOMINAL		In A	FLOW m³/h	MAX OBTAINABLE PRESSURE BAR	STANDARD PRESSURE BAR
		kW	HP				
2 K 35/40 M	1x220-240 V ~	2x0,75	2x1	2x5,5	9.0-6.0	4.2	2.5
2 K 45/50 M	1x220-240 V ~	2x1,1	2x1,5	2x8,3	10.8-6.0	5.2	3.5
2 K 55/50 M	1x220-240 V ~	2x1,85	2x2,5	2x12,8	12.0-7.0	6.2	4
2 K 35/40 T	3x400 V ~	2x0,75	2x1	2x3,5	9.6-6.0	4.2	2.5
2 K 45/50 T	3x400 V ~	2x1,1	2x1,5	2x3,6	10.8-6.0	5.2	3.5
2 K 55/50 T	3x400 V ~	2x1,85	2x2,5	2x4,8	12.0-7.0	6.2	4
2 K 55/100 T	3x400 V ~	2x2,2	2x3	2x6,7	18.0-10.0	6.2	4
2 K 66/100 T	3x400 V ~	2x3	2x4	2x8,4	18.0-10.0	7.3	5
2 K 90/100 T	3x400 V ~	2x4	2x5,5	2x9,7	21.0-14.0	8.4	6

MODEL	A	B	C	D	E	H	H1	H2	Ø MANIFOLDS		WEIGHT kg
									DNA (suc.)	DNM (del.)	
2 K 35/40 M	700	540	500	555	400	910	457	150	2"	1 1/2"	69
2 K 45/50 M	700	540	500	555	400	910	480	205	2"	1 1/2"	85
2 K 55/50 M	700	540	500	555	400	910	480	205	2"	1 1/2"	92
2 K 35/40 T	700	540	500	555	400	910	457	150	2"	1 1/2"	73
2 K 45/50 T	700	540	500	555	400	910	480	205	2"	1 1/2"	89
2 K 55/50 T	700	540	500	555	400	910	480	205	2"	1 1/2"	92
2 K 55/100 T	900	580	500	545	400	1120	570	220	2 1/2"	2 1/2"	155
2 K 66/100 T	900	580	500	545	400	1120	570	220	2 1/2"	2 1/2"	160
2 K 90/100 T	900	580	500	545	400	1120	570	220	2 1/2"	2 1/2"	167