



TECHNICAL DATA

Operating range: from 1 to 14.4 m³/h.

Pumped liquid: clean, free of solids and abrasives, non viscous, non aggressive, non crystallised and chemically neutral, with properties similar to water.

Pumped liquid temperature range: from 0 °C to +35°C.

Maximum ambient temperature: +40°C.

Maximum operating pressure: PN10.

Special executions on request: contact our sales network.

Protection class: IP44.

IE2 motors as standard from 0,75 kW to 5,5 kW - IE3 ≥ 7,5 kW.

APPLICATIONS

Water lifting sets particularly suited for domestic use, and small civil, agricultural, or industrial systems. The JET self-priming pumps used have the characteristic of also working when water, gas, or small amounts of sand are present in the water. These pumps are invaluable when drawing water from artesian wells and in case of suction difficulties. Their main features are utmost reliability, simple operation, and the fact that no maintenance is required. The sets are supplied as standard with tanks and with air supply connector.

CONSTRUCTION FEATURES

HYDRAULIC SECTION

2 JET centrifugal self-priming pumps. Tropicalized galvanized sheet steel base complete with 4 rubber anti-vibration feet. Suction and delivery manifolds in tropicalized galvanized steel. 2 membrane tanks. Ball valves with unions on the suction and delivery ports of each pump. Check valves on the suction port of each pump. 1 1/4" air supply connection at the suction of each pump. 2 tropicalized galvanized cast iron female plugs for closing the manifolds. 1 pressure transmitter on the delivery manifold (pressure detection).

ELECTRICAL SECTION

Supplied in an IP 55 protection class self-extinguishing thermoplastic material box, the control panel protects the electric pumps from abnormal conditions such as: overload and overtemperature (with automatic reset), short circuit (with fuses - Plus model only), pump current surges (amperometric protection), abnormal voltage, dry run, quick starts, pressure sensor fault, or inconsistency of the external protection commands.

FRONT PANEL COMPONENTS:

General disconnecter with padlockable door lock. AUT-O-MAN operation selection pushbuttons. Alarm RESET pushbutton. Display for all models. Operation, stop, alarm notification lamps.

PANEL INTERNAL COMPONENTS:

Electronic control card with protection fuses and contactors. Power input connection terminals (single phase or three phase). Dry run or overpressure pressure switch connection terminals (optional). Alarm notification N.O. contacts.

Function selection mini dip switch (pressure transmitter or pressure switches, standard or additional tanks).

The electric control panel is ready for the connection of:

Dry run protection float or pressure switch kit (*).

Overpressure stop pressure switch kit (*).

(* available separately as optional.

The sets are supplied in a sturdy cardboard packaging on wooden pallet and installation / maintenance manual with electric diagram.

MATERIALS

N.	PARTS*	MATERIALS
1	PUMP BODY	CAST IRON 200 UNI ISO 185
3	SUPPORT	DIE-CAST ALUMINIUM
4	IMPELLER	TECHNOPOLYMER A
7	SHAFT WITH ROTOR	AISI 416 STAINLESS STEEL X12 CrS13 - UNI 6900/71
16	MECHANICAL SEAL	CARBON / CERAMIC
28	OR RING	NBR RUBBER
160	VENTURI DIFFUSER NOZZLE ASSEMBLY	TECHNOPOLYMER A

* In contact with the liquid

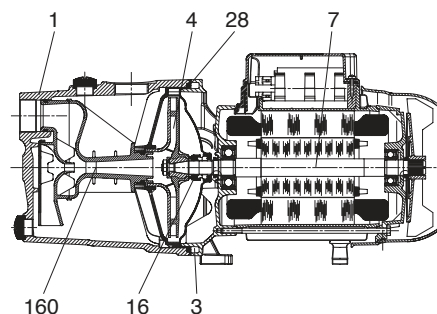

2 JET - CIVIL USE PRESSURE BOOSTER SETS

Pumped liquid temperature range: from 0°C to +35°C - Maximum ambient temperature: +40 °C - Max flow rate: 14.4 m³/h

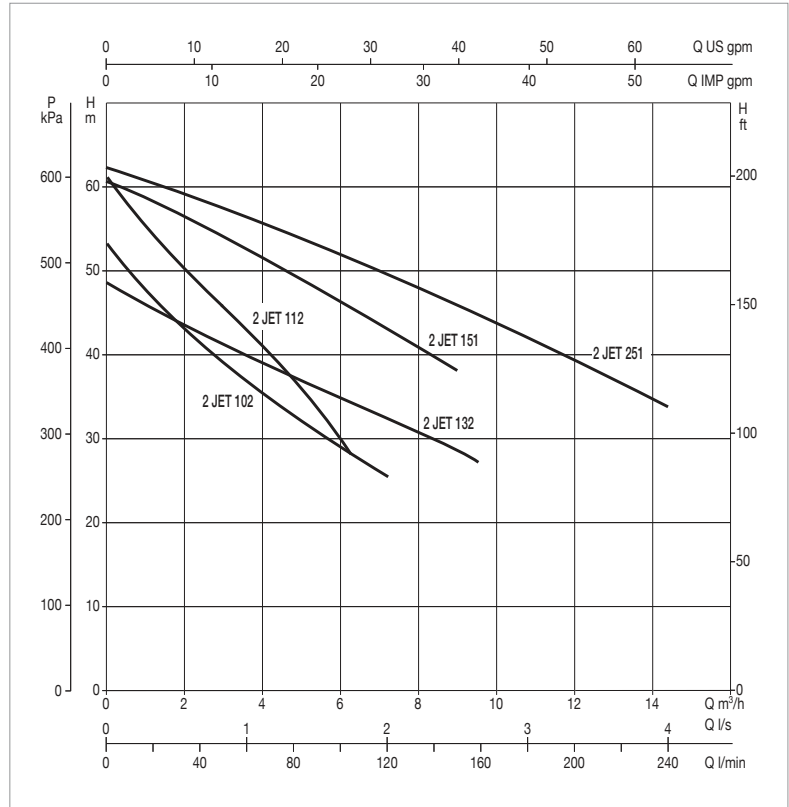
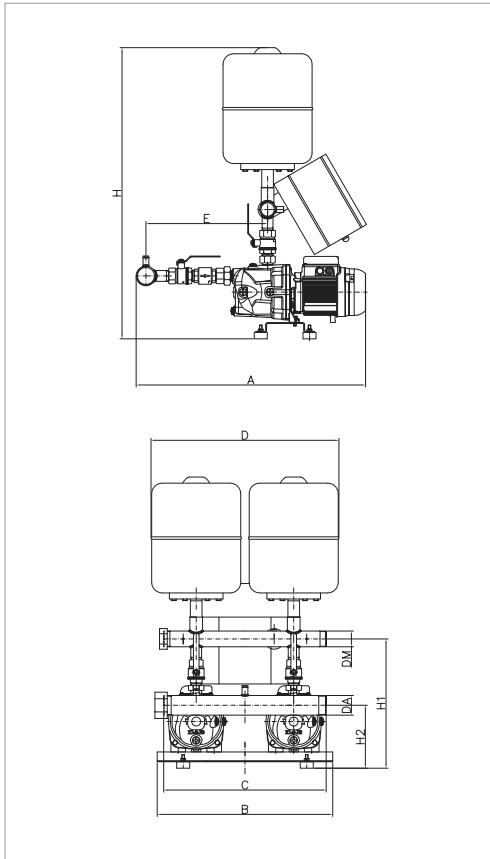

The performance curves are based on kinematic viscosity values = 1 mm²/s and density equal to 1000 kg/m³.
Curve tolerance according to ISO 9906.

MODEL	POWER INPUT 50 Hz	P2 NOMINAL		In A	FLOW m ³ /h	MAX OBTAINABLE PRESSURE BAR	STANDARD PRESSURE BAR
		kW	HP				
2 JET 102 M	1x220-240 V ~	2x0,75	2x1	2x5,1	6.6-3.0	5	3.5
2 JET 112 M	1x220-240 V ~	2x1	2x1,36	2x7	6.6-3.0	5.8	4
2 JET 132 M	1x220-240 V ~	2x1	2x1,36	2x7	9.6-3.0	4.6	3
2 JET 151 M	1x220-240 V ~	2x1,1	2x1,5	2x7,2	9.4-5.0	6.1	4
2 JET 251 M	1x220-240 V ~	2x1,85	2x2,5	2x10	14.0-7.2	6.4	4
2 JET 102 T	3x400 V ~	2x0,75	2x1	2x1,98	6.6-3.0	5	3.5
2 JET 112 T	3x400 V ~	2x1	2x1,36	2x2,7	6.6-3.0	5.8	4
2 JET 132 T	3x400 V ~	2x1	2x1,36	2x2,7	9.6-3.0	4.6	3
2 JET 151 T	3x400 V ~	2x1,1	2x1,5	2x3	9.4-5.0	6	4
2 JET 251 T	3x400 V ~	2x1,85	2x2,5	2x4	14.4-7.2	6	4

MODEL	A	B	C	D	E	H	H1	H2	Ø MANIFOLDS		WEIGHT kg
									DNA (suc.)	DNM (del.)	
2 JET 102 M	715	540	500	575	385	830	398	194	2"	1 1/2"	71
2 JET 112 M	715	540	500	575	385	830	398	194	2"	1 1/2"	74
2 JET 132 M	715	540	500	575	385	830	398	194	2"	1 1/2"	77
2 JET 151 M	715	540	500	565	385	830	398	194	2"	1 1/2"	101
2 JET 251 M	715	540	500	575	385	830	398	194	2"	1 1/2"	75
2 JET 102 T	715	540	500	575	385	830	398	194	2"	1 1/2"	75
2 JET 112 T	715	540	500	575	385	830	398	194	2"	1 1/2"	78
2 JET 132 T	715	540	500	575	385	830	398	194	2"	1 1/2"	81
2 JET 151 T	960	540	500	565	535	850	458	184	2"	1 1/2"	105
2 JET 251 T	960	540	500	565	535	850	458	184	2"	1 1/2"	108